

LEAST MATERIAL CONDITION

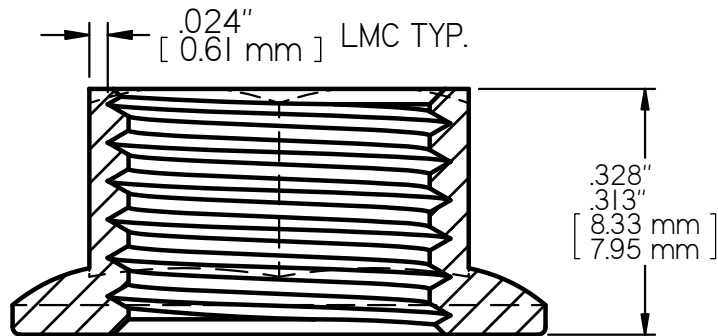
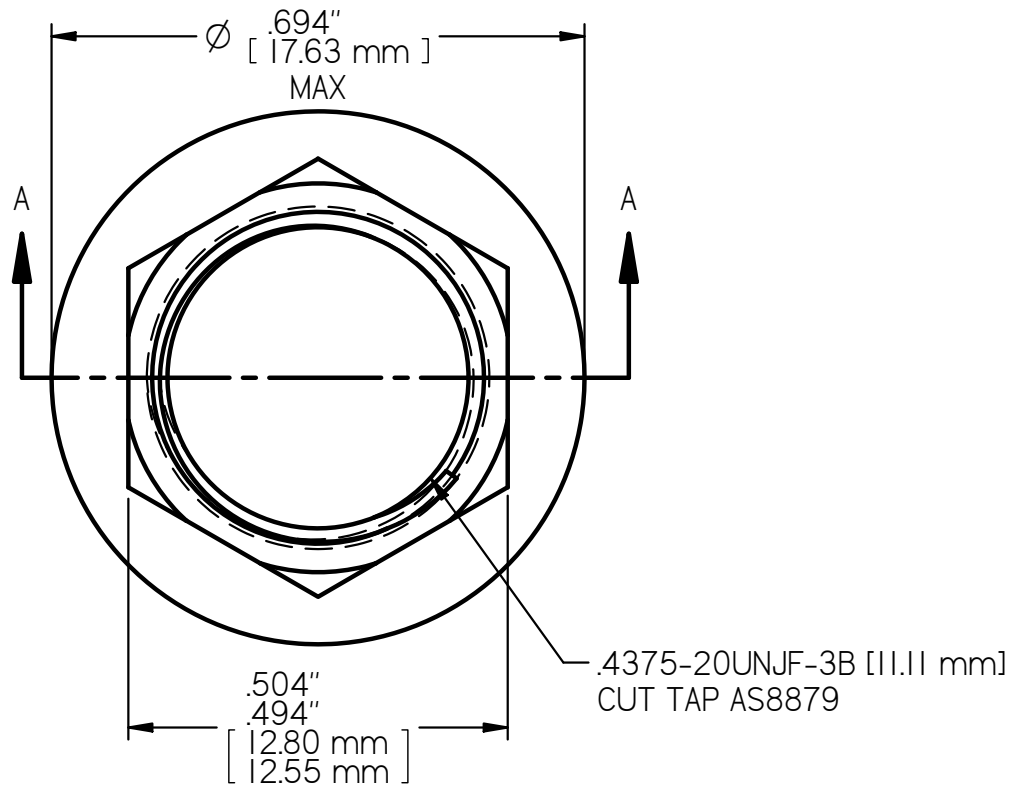

SECTION A-A
4X SCALE

NAS1291-7 LOCK NUT
AXIAL STRENGTH: 20,600 LBS. [91,633 N.] MIN

LEAST MATERIAL CONDITION

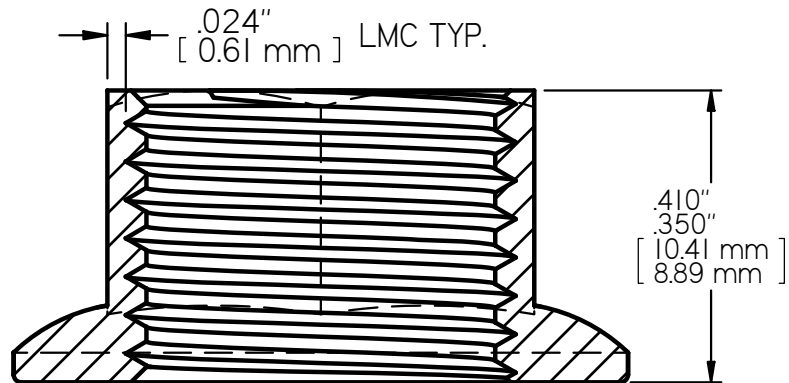
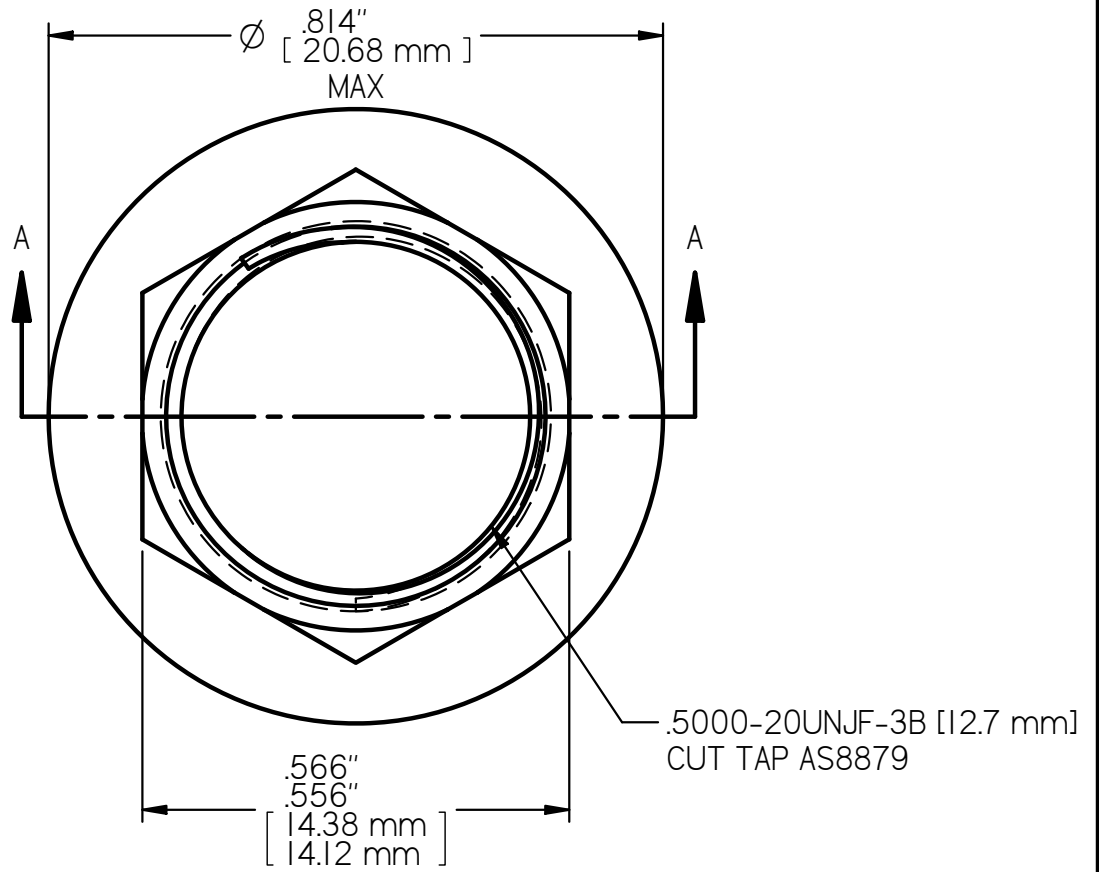

SECTION A-A
4X SCALE

NAS1291-8 LOCK NUT
AXIAL STRENGTH: 27,500 LBS. [122,326 N.] MIN

LEAST MATERIAL CONDITION

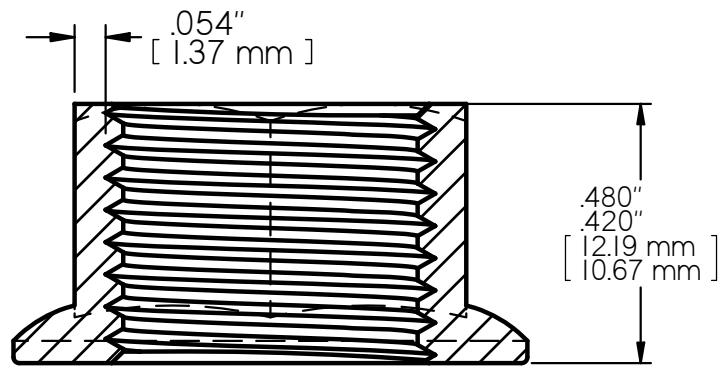
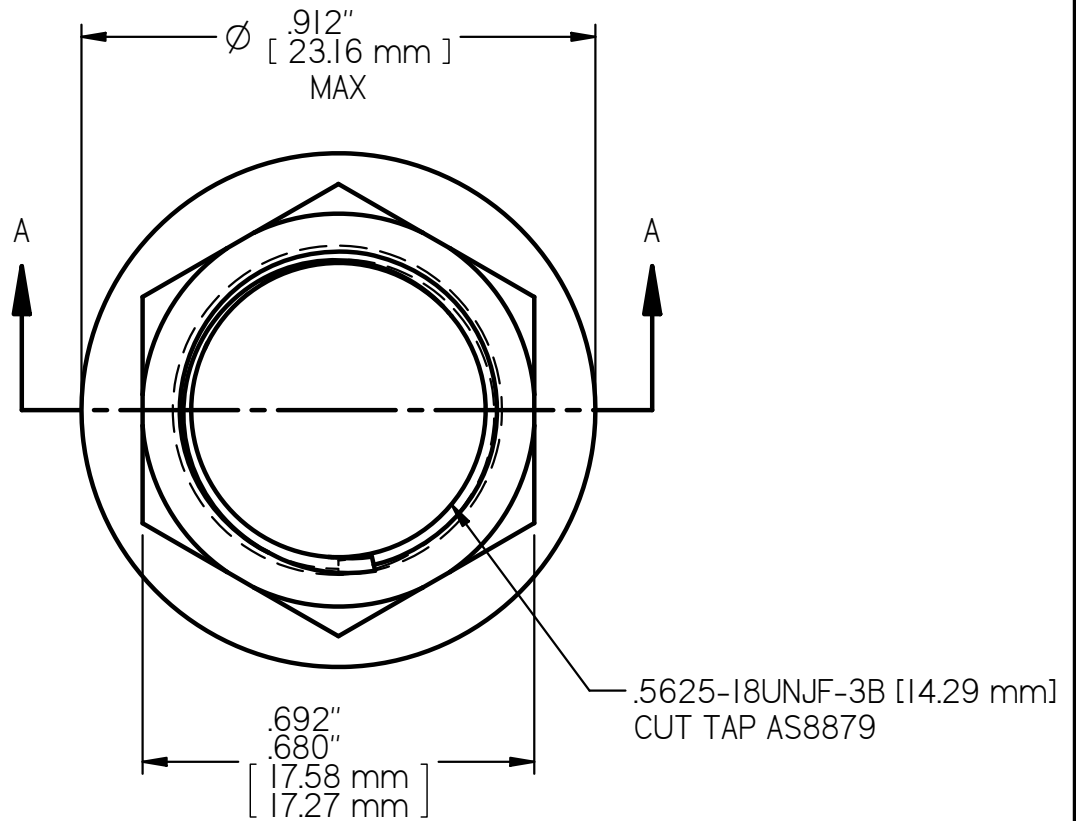

SECTION A-A
3X SCALE

NAS1291-9 LOCK NUT
AXIAL STRENGTH: 34,800 LBS. [154,798 N.] MIN

LEAST MATERIAL CONDITION

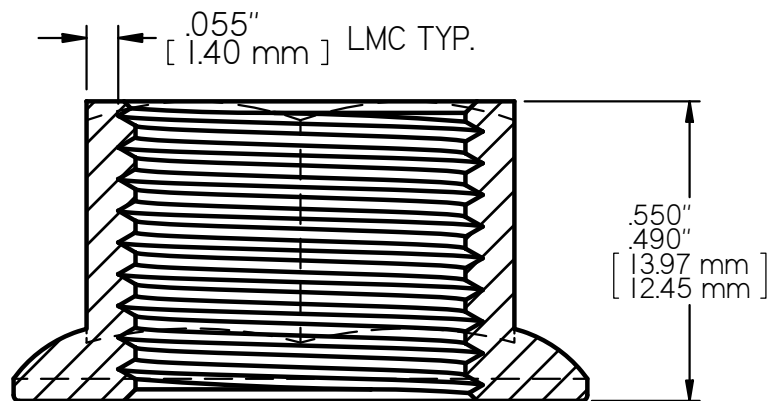
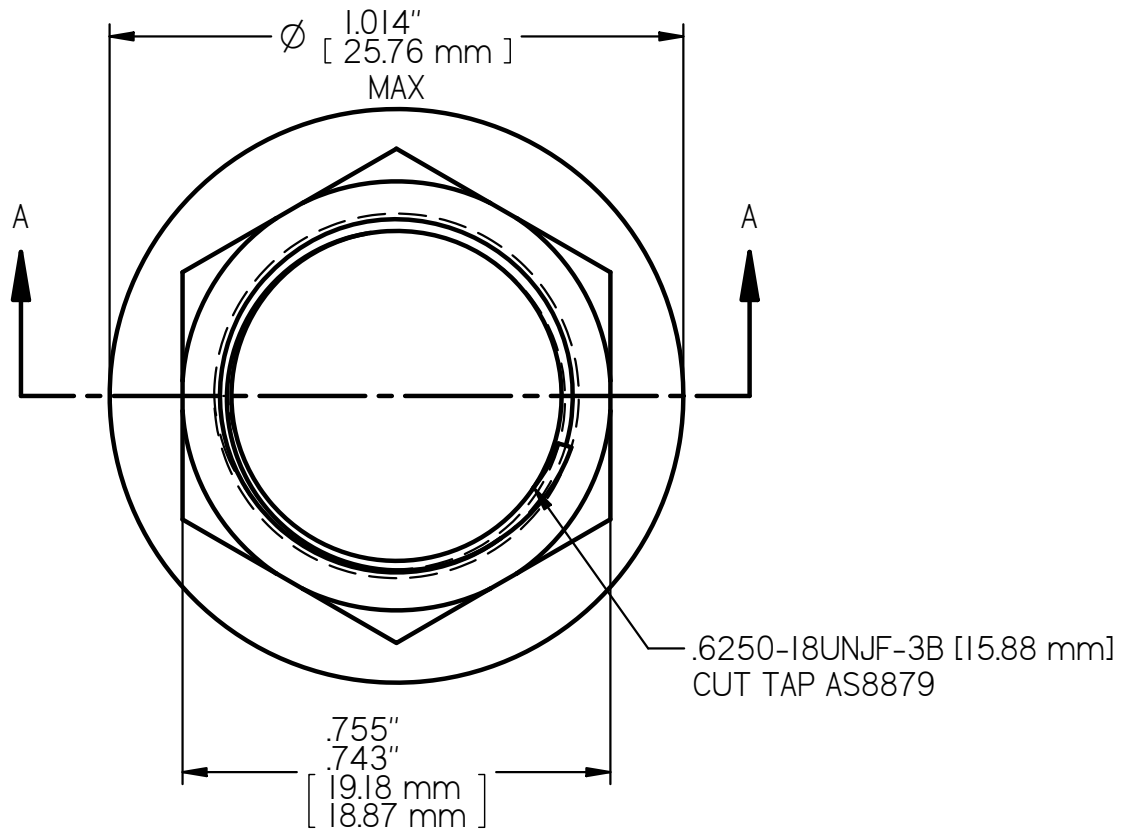

3X SCALE
SECTION A-A

NAS1291-10 LOCK NUT
AXIAL STRENGTH: 43,600 LBS. [193,943 N.] MIN