



DESCRIPTION

The A7407 is a wide input range, high-efficiency, and high frequency DC-to-DC step-down switching regulator, capable of delivering up to 0.7A of output current. With a fixed switching frequency of 660KHz, this current mode PWM controlled converter allows the use of small external components, such as ceramic input and output caps, as well as small inductors. A7407 also employs a proprietary control scheme that switches the device into a power save mode during light load, thereby extending the range of high efficiency operation. An OVP function protects the IC itself and its downstream system against input voltage surges. With this OVP function, the IC can stand off input voltage as high as 42V, making it an ideal solution for industrial applications such as smart meters as well as automotive applications.

In automotive systems, power comes from the battery, with its voltage typically between 9V and 24V. Including cold crank and double battery jump-starts, the minimum input voltage may be as low as 4V and the maximum up to 36V, with even higher transient voltages. With these high input voltages, linear regulators cannot be used for high supply currents without overheating the regulator. Instead, high efficiency switching regulators such as A7407 must be used to minimize thermal dissipation.

The A7407 is available in SOT-26 package.

ORDERING INFORMATION

Package Type	Part Number	
SOT-26	E6	A7407E6R
		A7407E6VR
Note	V: Halogen free Package R: Tape & Reel	
AiT provides all RoHS products		
Suffix " V " means Halogen free Package		

FEATURES

- Wide Input Operating Range from 4V to 38V
- Standoff Input Voltage: 42V
- High Efficiency at 12V In 5V Out: Up to 92%:
- High Efficiency PFM mode at light load
- Capable of Delivering 0.7A
- No External Compensation Needed
- Current Mode control
- Logic Control Shutdown
- Thermal shutdown and UVLO
- Available in SOT-26 Package

APPLICATION

- Smart Meters
- Industrial Applications
- Automotive Applications

TYPICAL APPLICATION

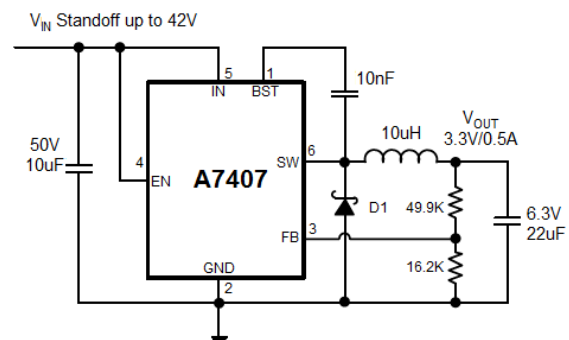



PIN DESCRIPTION

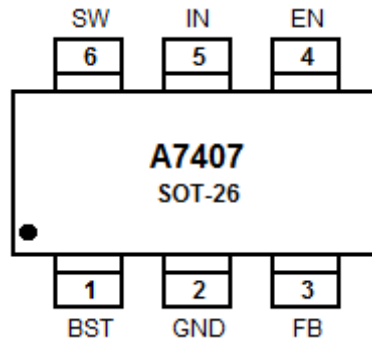

Top View

Pin #	Symbol	Function
1	BST	Bootstrap pin. Connect a 10nF capacitor from this pin to SW
2	GND	Ground
3	FB	Feedback Input. Connect an external resistor divider from the output to FB and GND to set V_{OUT}
4	EN	Enable pin for the IC. Drive this pin high to enable the part, low to disable.
5	IN	Supply Voltage. Bypass with a 10 μ F ceramic capacitor to GND
6	SW	Inductor Connection. Connect an inductor Between SW and the regulator output.



ABSOLUTE MAXIMUM RATINGS

Input Voltage Range	-0.3V~42V
Max Operating Junction Temperature(Tj)	150°C
SW, EN Voltage	-0.3V~ V _{IN} +0.3V
BST Voltage	-0.3V ~ SW+6V
FB Voltage	-0.3V ~ 6V
SW to ground current	Internally limited
T _J , Operating Junction Temperature	-40°C ~85°C
θ _{JC} , Package Thermal Resistance	110°C/W
T _s , Storage Temperature	-55°C~150°C

Stress beyond above listed "Absolute Maximum Ratings" may lead permanent damage to the device. These are stress ratings only and operations of the device at these or any other conditions beyond those indicated in the operational sections of the specifications are not implied. Exposure to absolute maximum rating conditions for extended periods may affect device reliability.

ELECTRICAL CHARACTERISTICS

V_{IN} = 12V, unless otherwise specified. Typical values are at T_A = 25°C.

Parameter	Conditions	Min.	Typ.	Max.	Unit
Input Standoff Voltage		42			V
Input Voltage Range		4		38	V
Input UVLO	Rising, Hysteresis=140mV		3.8		V
Input OVP	Rising, Hysteresis=1.3V		38		V
Input Supply Current	V _{FB} =0.85V		0.6		mA
Input Shutdown Current			6		μA
FB Feedback Voltage			0.8		V
FB Input Current			0.01		μA
Switching Frequency			660		KHz
Maximum Duty Cycle		90			%
FoldBack Frequency	V _{FB} = 0V		60		KHz
High side Switch On Resistance	I _{SW} =200mA		400		mΩ
High side Switch Current Limit			1.2		A
SW Leakage Current	V _{IN} =12V,V _{SW} =0, EN= GND			10	μA
EN Input Current	V _{IN} =12V ,V _{EN} =5V		1	5	μA
EN Input Low Voltage	Rising, Hysteresis=100mV	0.8	1.1	1.4	V
Thermal Shutdown	Hysteresis=40°C		150		°C



TYPICAL PERFORMANCE CHARACTERISTICS

Typical values are at $T_A=25^\circ\text{C}$, unless otherwise specified.

1. Efficiency vs. I_{OUT}

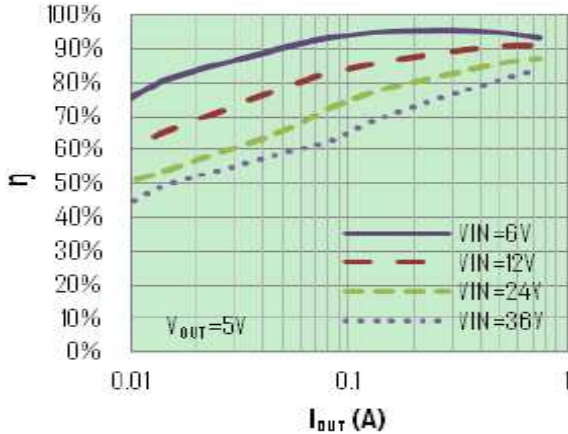

2. Efficiency vs. I_{OUT}

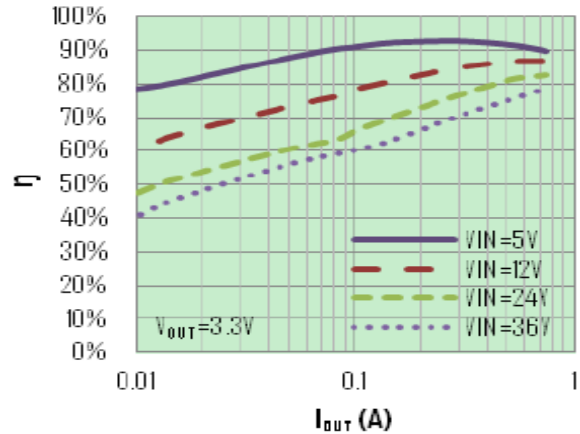

3. I_Q vs. V_{IN}

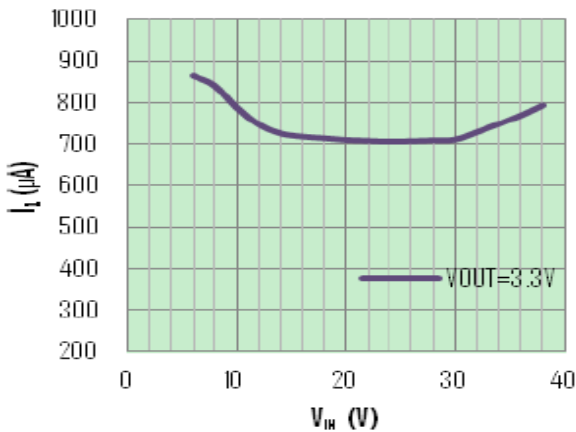

4. V_{OUT} vs. I_{OUT}

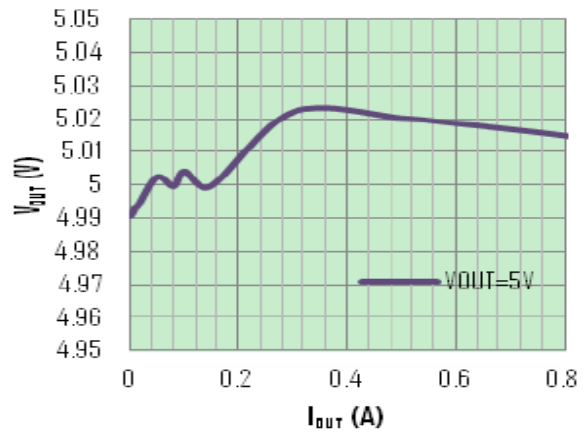

5. V_{OUT} vs. V_{IN}

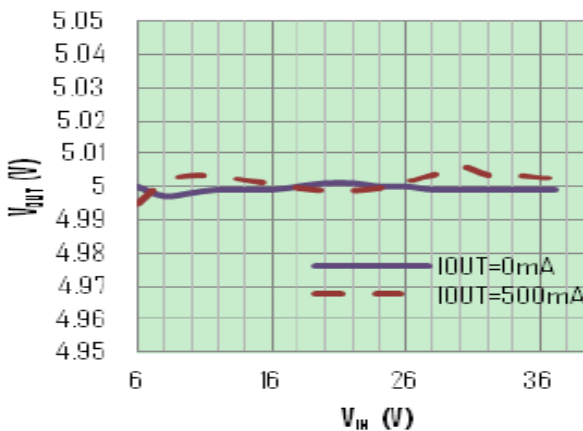

6. V_{OUT} vs. Temperature

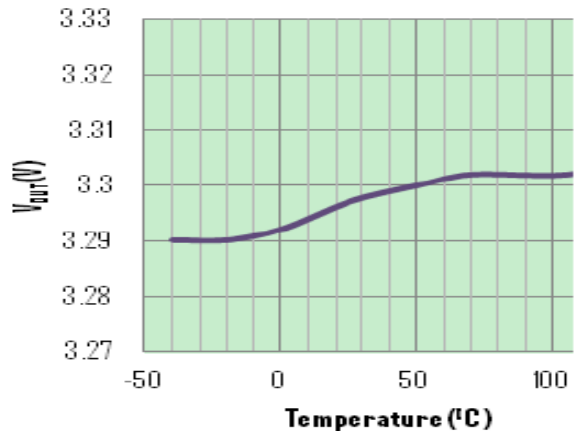



7. Frequency vs. Temperature

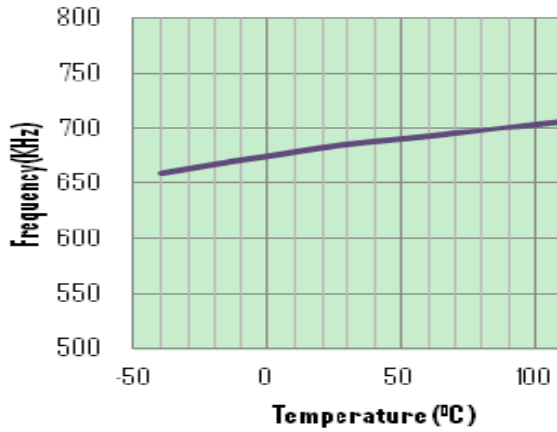

8. Start-up Waveform with EN

$V_{IN}=12V, V_{OUT}=5V, I_{OUT}=0A$

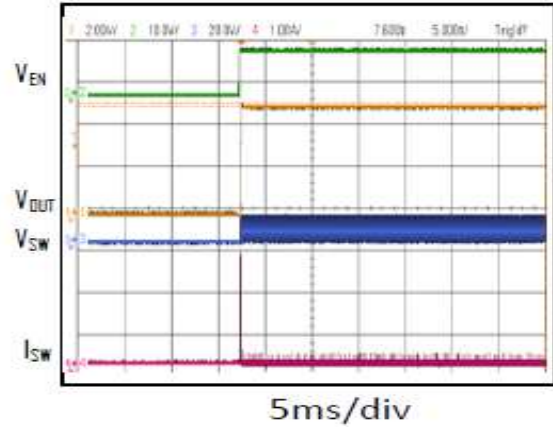

9. Start-up Waveform with EN= V_{IN}

$V_{IN}=12V, V_{OUT}=5V, I_{OUT}=0A$

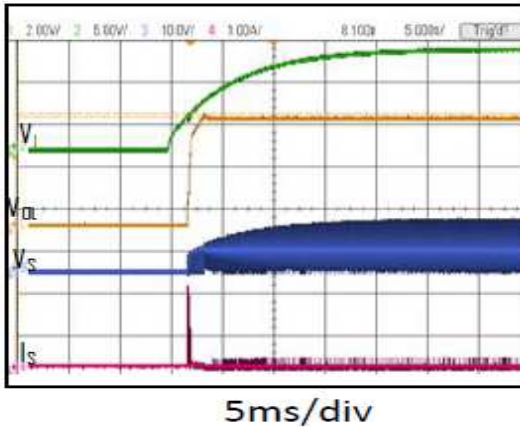

10. Shutdown Waveform with EN

$V_{IN}=30V, V_{OUT}=5V, I_{OUT}=0.5A$

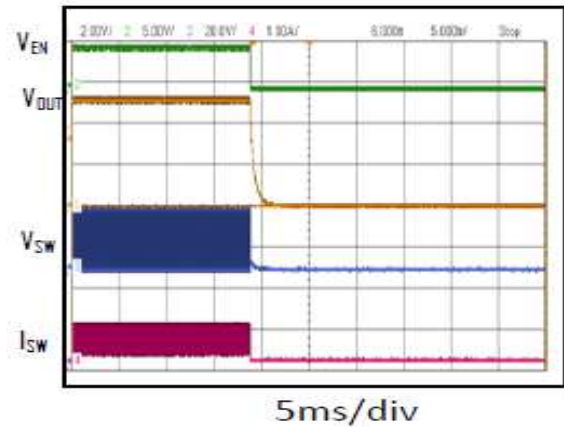

11. Switching Waveform

$V_{IN}=12V, V_{OUT}=5V, I_{OUT}=0.1A$

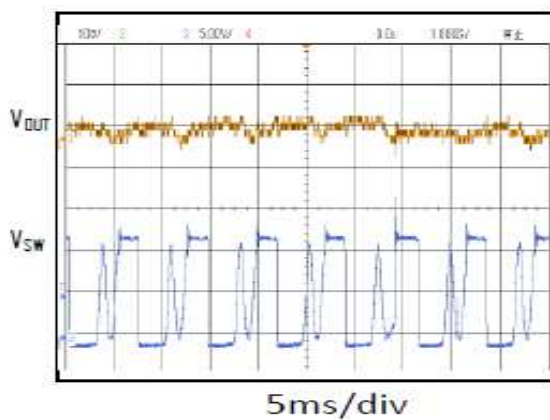

12. Switching Waveform

$V_{IN}=12V, V_{OUT}=5V, I_{OUT}=0.3A$

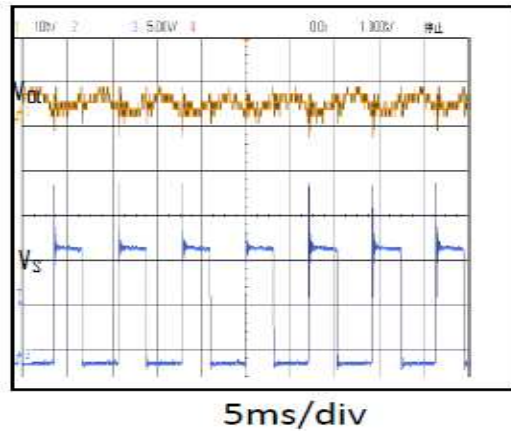



13. Load Transient Response

$V_{IN}=12V, V_{OUT}=3.3V, I_{OUT}=0$ to $0.5A$

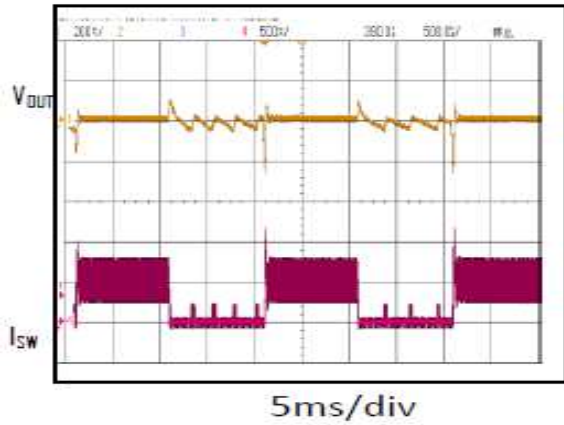

14. Load Transient Response

$V_{IN}=12V, V_{OUT}=5V, I_{OUT}=0$ to $0.5A$

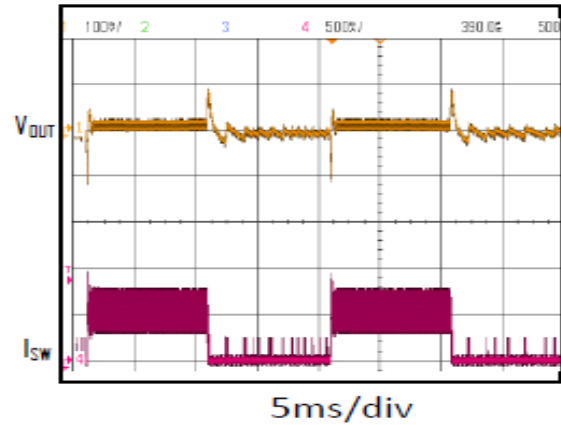

15. Short-Circuit Response

$V_{IN}=24V, V_{OUT}=5V, I_{OUT}=0$ to Short

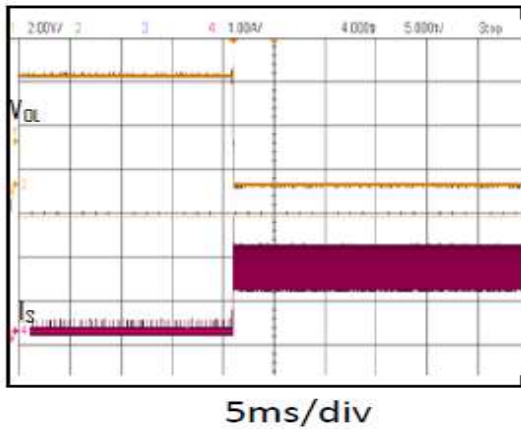

16. Short-Circuit Recovery

$V_{IN}=24V, V_{OUT}=5V, I_{OUT}=$ Short to $0A$

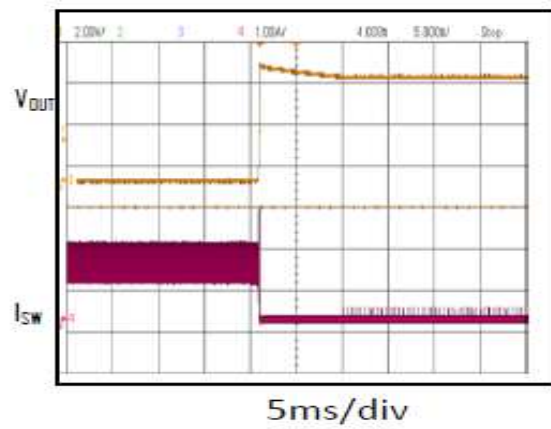



BLOCK DIAGRAM

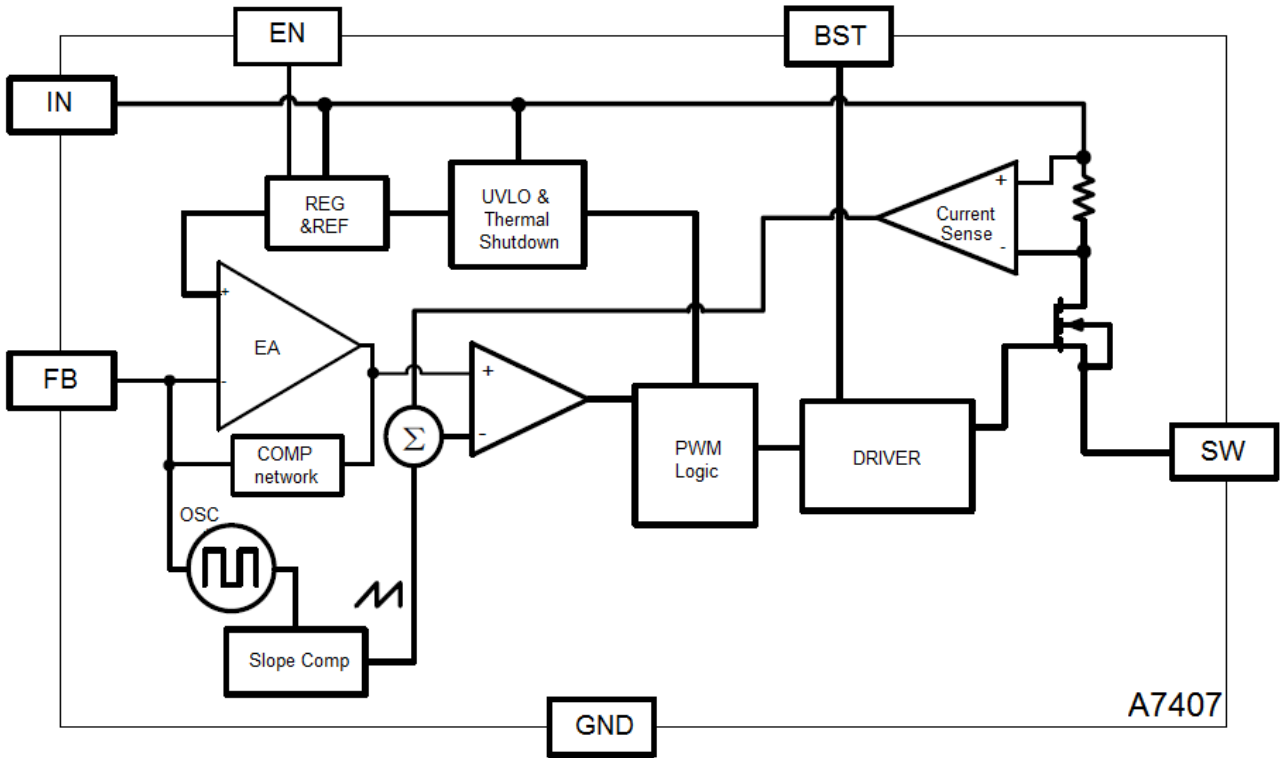



DETAILED INFORMATION

Functional Descriptions

Loop Operation

The A7407 is a wide input range, high-efficiency, DC-to-DC step-down switching regulator, capable of delivering up to 0.7A of output current, integrated with a 400mΩ high side MOSFET. It uses a PWM current-mode control scheme. An error amplifier integrates error between the FB signal and the internal reference voltage. The output of the integrator is then compared to the sum of a current-sense signal and the slope compensation ramp. This operation generates a PWM signal that modulates the duty cycle of the power MOSFETs to achieve regulation for output voltage.

Light Load Operation

Traditionally, a fixed constant frequency PWM DC-DC regulator always switches even when the output load is small. When energy is shuffling back and forth through the power MOSFETs, power is lost due to the finite RDS(ON)s of the MOSFETs and parasitic capacitances. At light load, this loss is prominent and efficiency is therefore very low. A7407 employs a proprietary control scheme that improves efficiency in this situation by enabling the device into a power save mode during light load, thereby extending the range of high efficiency operation.

Application Information

Setting Output Voltages

Output voltages are set by external resistors. The FB threshold is 0.8V.

$$R_{TOP} = R_{BOTTOM} \times [(V_{OUT} / 0.8) - 1]$$

Inductor Selection

The peak-to-peak ripple is limited to 30% of the maximum output current. This places the peak current far enough from the minimum over current trip level to ensure reliable operation while providing enough current ripples for the current mode converter to operate stably. In this case, for 0.7A maximum output current, the maximum inductor ripple current is 300mA. The inductor size is estimated as following equation:

$$L_{IDEAL} = (V_{IN(MAX)} - V_{OUT}) / I_{RIPPLE} * D_{MIN} * (1 / F_{OSC})$$

Therefore, for $V_{OUT}=5V$, the inductor values is calculated to be $L=13\mu H$. Chose $10\mu H$ or $15\mu H$

For $V_{OUT}=3.3V$, the inductor values is calculated to be $L=9.2\mu H$. Chose $10\mu H$



Output Capacitor Selection

For most applications a nominal 22 μ F or larger capacitor is suitable. The A7407 internal compensation is designed for a fixed corner frequency that is equal to $f_C = 8.7\text{KHz}$

For example, for $V_{OUT} = 5\text{V}$, $L = 15\mu\text{H}$, $C_{OUT} = 22\mu\text{F}$.

The output capacitor keeps output ripple small and ensures control-loop stability. The output capacitor must also have low impedance at the switching frequency. Ceramic, polymer, and tantalum capacitors are suitable, with ceramic exhibiting the lowest ESR and high-frequency impedance. Output ripple with a ceramic output capacitor is approximately as follows:

$$V_{\text{RIPPLE}} = I_{L(\text{PEAK})} [1 / (2\pi \times f_{\text{OSC}} \times C_{\text{OUT}})]$$

If the capacitor has significant ESR, the output ripple component due to capacitor ESR is as follows:

$$V_{\text{RIPPLE(ESR)}} = I_{L(\text{PEAK})} \times \text{ESR}$$

Input Capacitor Selection

The input capacitor in a DC-to-DC converter reduces current peaks drawn from the battery or other input power source and reduces switching noise in the controller. The impedance of the input capacitor at the switching frequency should be less than that of the input source so high-frequency switching currents do not pass through the input source. The output capacitor keeps output ripple small and ensures control-loop stability.

Components Selection

V_{OUT} (V)	C_{OUT} (μF)	L (μH)
8.0	22	15 to 22
5.0	22	10 to 15
3.3	22	6.8 to 10



PACKAGE INFORMATION

Dimension in SOT-26 Package (Unit: mm)

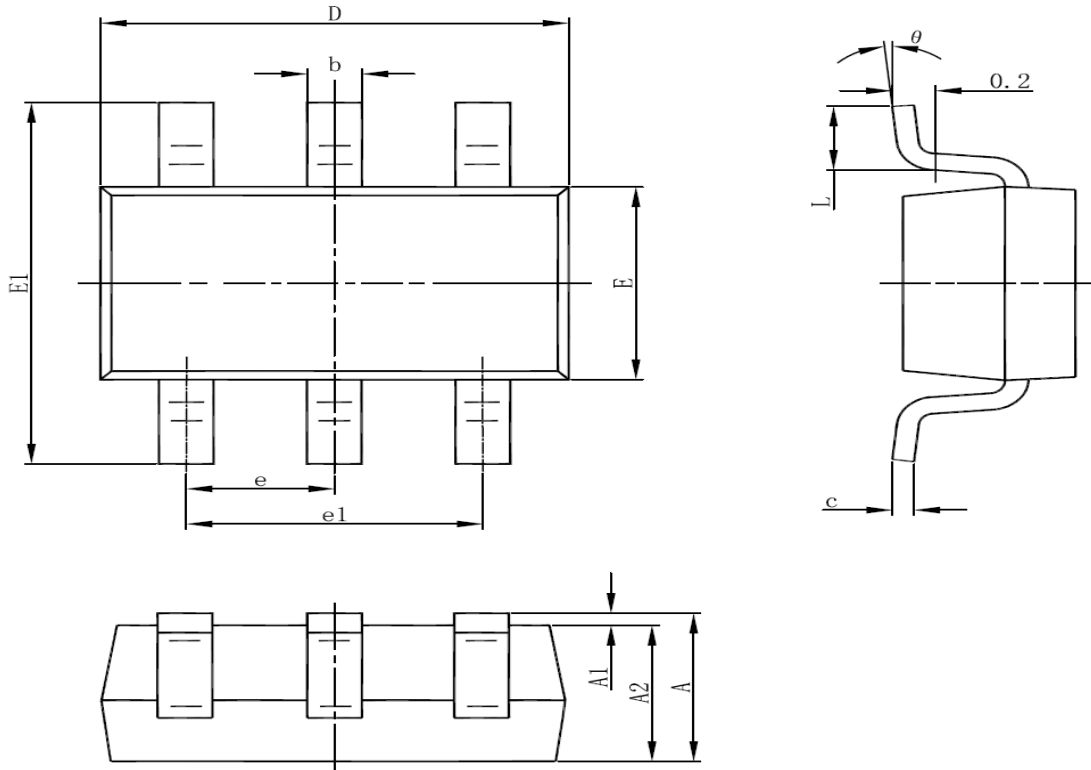

SYMBOL	MIN	MAX
A	1.050	1.250
A1	0.000	0.100
A2	1.050	1.150
b	0.300	0.500
c	0.100	0.200
D	2.820	3.020
E	1.500	1.700
E1	2.650	2.950
e	0.950(BSC)	
e1	1.800	2.000
L	0.300	0.600
θ	0°	8°



IMPORTANT NOTICE

AiT Semiconductor Inc. (AiT) reserves the right to make changes to any its product, specifications, to discontinue any integrated circuit product or service without notice, and advises its customers to obtain the latest version of relevant information to verify, before placing orders, that the information being relied on is current.

AiT Semiconductor Inc.'s integrated circuit products are not designed, intended, authorized, or warranted to be suitable for use in life support applications, devices or systems or other critical applications. Use of AiT products in such applications is understood to be fully at the risk of the customer. As used herein may involve potential risks of death, personal injury, or severe property, or environmental damage. In order to minimize risks associated with the customer's applications, the customer should provide adequate design and operating safeguards.

AiT Semiconductor Inc. assumes to no liability to customer product design or application support. AiT warrants the performance of its products of the specifications applicable at the time of sale.