

# NHD-14432WG-BTFH-V#T

## Graphic Liquid Crystal Display Module

NHD-	Newhaven Display
14432-	144 x 32 Pixels
WG-	Display type: Graphic
B-	Model
T-	White LED backlight
F-	FSTN (+)
H-	Transflective, 6:00 Optimal View, Wide Temperature
V#T-	Built-in Positive Voltage
	<b>RoHS Compliant</b>

**Newhaven Display International, Inc.**

2661 Galvin Ct.

Elgin IL, 60124

Ph: 847-844-8795

Fax: 847-844-8796

[www.newhavendisplay.com](http://www.newhavendisplay.com)

[nhtech@newhavendisplay.com](mailto:nhtech@newhavendisplay.com)

[nhsales@newhavendisplay.com](mailto:nhsales@newhavendisplay.com)

## Document Revision History

Revision	Date	Description	Changed by
0	10/16/08	Initial Release	-
1	4/5/10	User guide reformat	BE
2	5/10/10	Block diagram/optical updated	BE
3	5/14/10	Updated Mechanical Drawing	MC
4	1/24/12	Timing characteristics updated	AK
5	6/7/13	Controller information added	AK
6	11/4/16	Electrical Characteristics Updated	TM
7	3/8/17	Backlight Characteristics Updated	SB
8	7/5/17	Backlight Characteristics Updated	TM
9	3/5/18	Backlight Voltage Corrected	SB

## Functions and Features

- 144x32 pixels
- Built-in ST7920-0C Controller
- +5.0V power supply
- 1/32 duty
- RoHS Compliant

# Mechanical Drawing

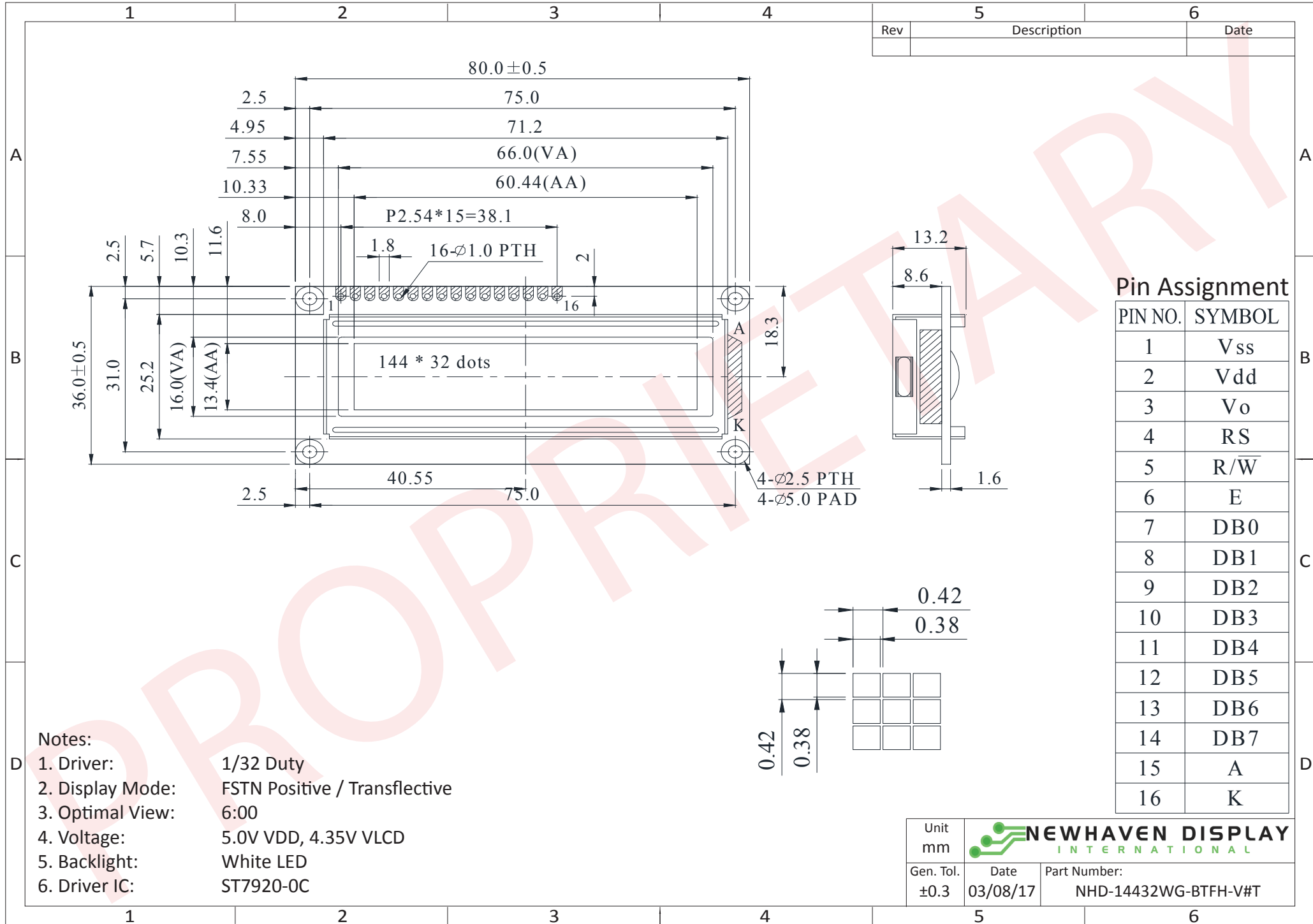

- Notes:
1. Driver: 1/32 Duty
  2. Display Mode: FSTN Positive / Transflective
  3. Optimal View: 6:00
  4. Voltage: 5.0V VDD, 4.35V VLCD
  5. Backlight: White LED
  6. Driver IC: ST7920-0C

Unit mm		
Gen. Tol. ±0.3	Date 03/08/17	Part Number: NHD-14432WG-BTFH-V#T

## Pin Description and Wiring Diagram

Pin No.	Symbol	External Connection	Function Description
1	V <sub>SS</sub>	Power Supply	Ground
2	V <sub>DD</sub>	Power Supply	Power supply for Logic (+5.0V)
3	V <sub>0</sub>	-	No Connect
4	RS	MPU	Register Select: 1=Data, 0=Instruction
5	R/W	MPU	Read/Write select signal, R/W=1: Read R/W: =0: Write
6	E	MPU	Operation Enable signal. Falling edge triggered.
7-14	DB0-DB7	MPU	This is an 8-bit bi-directional data bus
15	LED+	Power Supply	Backlight Anode (32 mA)
16	LED-	Power Supply	Backlight Cathode (Ground)

**Recommended LCD connector:** 2.54mm pitch pins

**Backlight connector:** -      **Mates with:** -

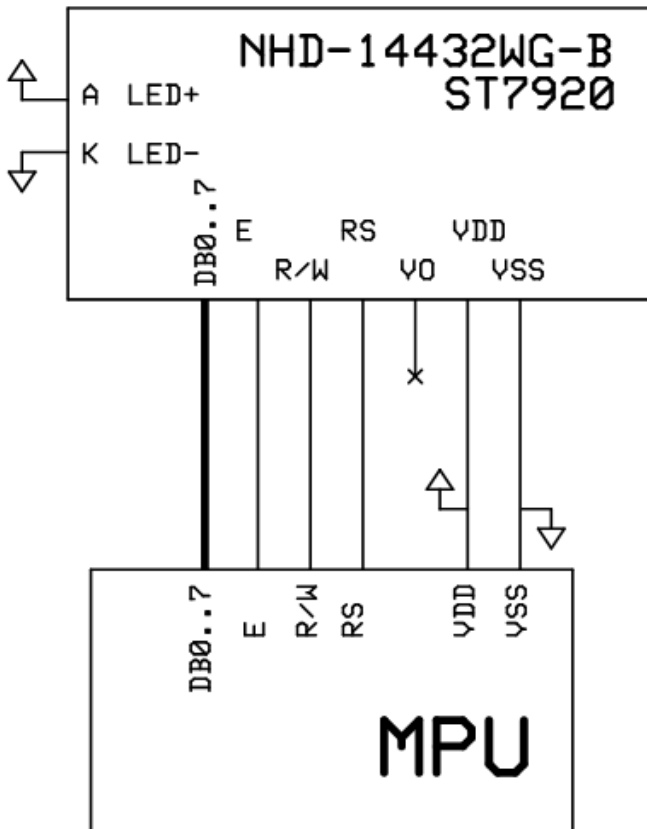

## Electrical Characteristics

Item	Symbol	Condition	Min.	Typ.	Max.	Unit
Operating Temperature Range	T <sub>OP</sub>	Absolute Max	-20	-	+70	°C
Storage Temperature Range	T <sub>ST</sub>	Absolute Max	-30	-	+80	°C
Supply Voltage	V <sub>DD</sub>	-	4.5	5.0	5.5	V
Supply Current	I <sub>DD</sub>	T <sub>OP</sub> = 25°	0.5	1.0	3.5	mA
Supply for LCD (contrast)	V <sub>LCD</sub>	V <sub>DD</sub> = 5.0V	4.1	4.35	4.5	V
"H" Level input	V <sub>IH</sub>	-	0.7 * V <sub>DD</sub>	-	V <sub>DD</sub>	V
"L" Level input	V <sub>IL</sub>	-	V <sub>SS</sub>	-	0.6	V
"H" Level output	V <sub>OH</sub>	-	0.8 * V <sub>DD</sub>	-	V <sub>DD</sub>	V
"L" Level output	V <sub>OL</sub>	-	V <sub>SS</sub>	-	0.4	V
Backlight Supply Voltage	V <sub>LED</sub>	-	3.4	3.5	3.6	V
Backlight Supply Current	I <sub>LED</sub>	V <sub>LED</sub> = 3.5V	10	30	40	mA

## Optical Characteristics

Item	Symbol	Condition	Min.	Typ.	Max.	Unit
Optimal Viewing Angles	Top	CR ≥ 2	-	30	-	°
	Bottom		-	60	-	°
	Left		-	45	-	°
	Right		-	45	-	°
Contrast Ratio	CR	-	2	5	-	-
Response Time	Rise	T <sub>OP</sub> = 25°C	-	150	200	ms
	Fall		-	150	200	ms

## Controller Information

Built-in ST7920-0C.

Please download specification at [http://www.newhavendisplay.com/app\\_notes/ST7920.pdf](http://www.newhavendisplay.com/app_notes/ST7920.pdf)

# Table of Commands

## Instruction Set 1: (RE=0: Basic Instruction)

Inst.	Code										Description	Exec time (540KHZ)
	RS	RW	DB7	DB6	DB5	DB4	DB3	DB2	DB1	DB0		
Display Clear	0	0	0	0	0	0	0	0	0	1	Fill DDRAM with "20H" and set DDRAM address counter (AC) to "00H".	1.6 ms
Return Home	0	0	0	0	0	0	0	0	1	X	Set DDRAM address counter (AC) to "00H", and put cursor to origin ; the content of DDRAM are not changed	72 us
Entry Mode Set	0	0	0	0	0	0	0	1	I/D	S	Set cursor position and display shift when doing write or read operation	72 us
Display Control	0	0	0	0	0	0	1	D	C	B	D=1: Display ON C=1: Cursor ON B=1: Character Blink ON	72 us
Cursor Display Control	0	0	0	0	0	1	S/C	R/L	X	X	Cursor position and display shift control; the content of DDRAM are not changed	72 us
Function Set	0	0	0	0	1	DL	X	0 RE	X	X	DL=1 8-bit interface DL=0 4-bit interface <b>RE=1: extended instruction</b> <b>RE=0: basic instruction</b>	72 us
Set CGRAM Address.	0	0	0	1	AC5	AC4	AC3	AC2	AC1	AC0	Set CGRAM address to address counter (AC) <b>Make sure that in extended instruction SR=0 (scroll or RAM address select)</b>	72 us
Set DDRAM Address.	0	0	1	0 AC6	AC5	AC4	AC3	AC2	AC1	AC0	Set DDRAM address to address counter (AC) AC6 is fixed to 0	72 us
Read Busy Flag (BF) & AC.	0	1	BF	AC6	AC5	AC4	AC3	AC2	AC1	AC0	Read busy flag (BF) for completion of internal operation, also Read out the value of address counter (AC)	0 us
Write RAM	1	0	D7	D6	D5	D4	D3	D2	D1	D0	Write data to internal RAM (DDRAM/CGRAM/GDRAM)	72 us
Read RAM	1	1	D7	D6	D5	D4	D3	D2	D1	D0	Read data from internal RAM (DDRAM/CGRAM/GDRAM)	72 us

**Instruction set 2: (RE=1: extended instruction)**

Inst.	Code										Description	Exec time (540KHZ)
	RS	RW	DB7	DB6	DB5	DB4	DB3	DB2	DB1	DB0		
Standby	0	0	0	0	0	0	0	0	0	1	Enter standby mode, any other instruction can terminate. COM1...32 are halted.	72 us
Scroll or RAM Address. Select	0	0	0	0	0	0	0	0	0	1 SR	SR=1: enable vertical scroll position SR=0: enable CGRAM address ( <b>basic instruction</b> )	72 us
Reverse (by line)	0	0	0	0	0	0	0	0	1 R1	R0	Select 1 out of 4 line (in DDRAM) and decide whether to reverse the display by toggling this instruction <b>R1,R0 initial value is 0,0</b>	72 us
Extended Function Set	0	0	0	0	1	DL	X	1 RE	G	0	DL=1 :8-bit interface DL=0 :4-bit interface <b>RE=1: extended instruction set</b> <b>RE=0: basic instruction set</b> G=1 :graphic display ON G=0 :graphic display OFF	72 us
Set Scroll Address	0	0	0	1	AC5	AC4	AC3	AC2	AC1	AC0	SR=1: AC5~AC0 the address of vertical scroll	72 us
Set Graphic Display RAM Address	0	0	1	0 0	0 AC5	0 AC4	AC3 AC3	AC2 AC2	AC1 AC1	AC0 AC0	Set GDRAM address to address counter (AC) Set the vertical address first and followed the horizontal address by consecutive writings Vertical address range: AC5...AC0 Horizontal address range: AC3...AC0	72 us

# Timing Characteristics

## MPU write data to ST7920

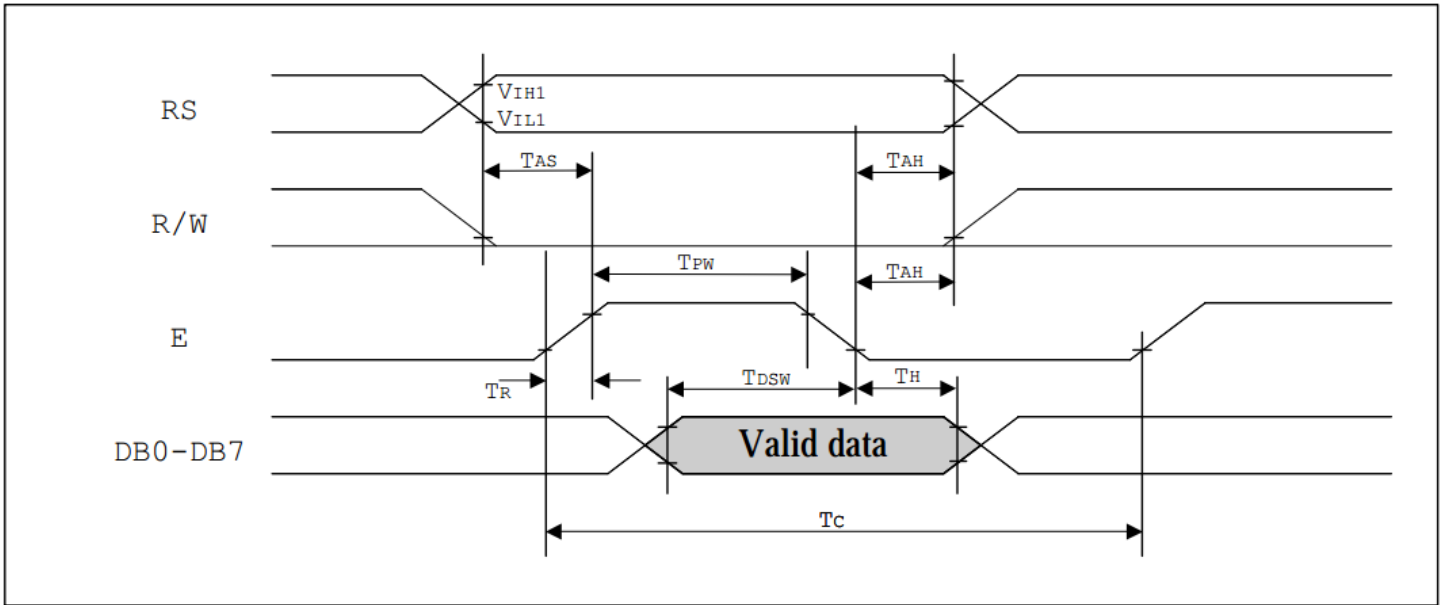

Write Mode (Writing data from MPU to ST7920)						
$T_C$	Enable Cycle Time	Pin E	1200	-	-	ns
$T_{PW}$	Enable Pulse Width	Pin E	140	-	-	ns
$T_R, T_F$	Enable Rise/Fall Time	Pin E	-	-	25	ns
$T_{AS}$	Address Setup Time	Pins: RS,RW,E	10	-	-	ns
$T_{AH}$	Address Hold Time	Pins: RS,RW,E	20	-	-	ns
$T_{DSW}$	Data Setup Time	Pins: DB0 - DB7	40	-	-	ns
$T_H$	Data Hold Time	Pins: DB0 - DB7	20	-	-	ns



## MPU read data from ST7920

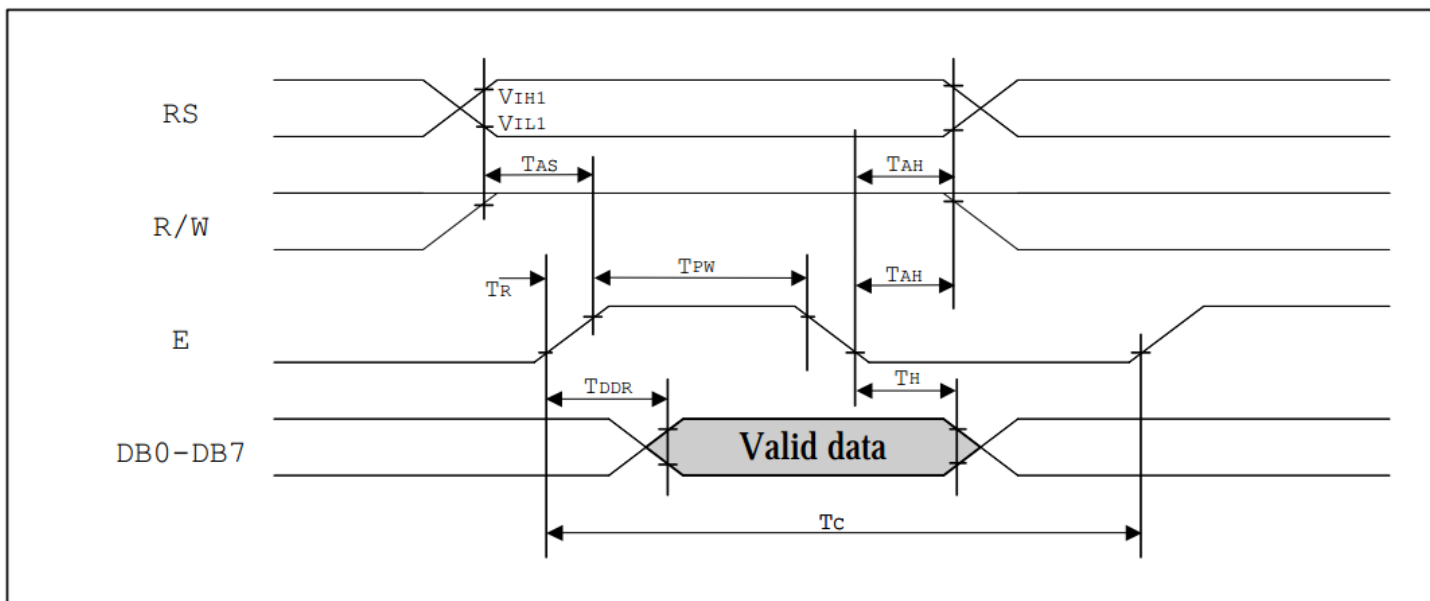

*Read Mode (Reading Data from ST7920 to MPU)*

<i>Read Mode (Reading Data from ST7920 to MPU)</i>						
$T_C$	Enable Cycle Time	Pin E	1200	-	-	ns
$T_{PW}$	Enable Pulse Width	Pin E	140	-	-	ns
$T_{R,T_F}$	Enable Rise/Fall Time	Pin E	-	-	25	ns
$T_{AS}$	Address Setup Time	Pins: RS,RW,E	10	-	-	ns
$T_{AH}$	Address Hold Time	Pins: RS,RW,E	20	-	-	ns
$T_{DDR}$	Data Delay Time	Pins: DB0 - DB7	-	-	100	ns
$T_H$	Data Hold Time	Pins: DB0 - DB7	20	-	-	ns

## Built-in Font Table

Please see: [http://www.newhavendisplay.com/appnotes/fonttables/GraphLCD/ST7920-0C\\_font.pdf](http://www.newhavendisplay.com/appnotes/fonttables/GraphLCD/ST7920-0C_font.pdf)

## Example Initialization Program

```
//-----  
#include <REG52.H>  
#include "AL.h"  
sbit ID = P3^0;  
sbit RW = P3^7;  
sbit E = P3^4;  
//-----  
void Init()  
{  
    Wcom(0x38);  
    Wcom(0x0C);  
    Wcom(0x06);  
    Wcom(0x02);  
    Wcom(0x01);  
    delay(10);  
    Row = 0x80;  
    for(Counthi = 1; Counthi <=32; Counthi++)  
    {  
        Wcom(0x3E);  
        Wcom(Row);  
        Wcom(0x80);  
        for(Count = 1; Count <=40; Count++)  
        {  
            Wdata(0x00);  
        }  
        Row++;  
    }  
}  
//-----  
void Wcom(char i)  
{  
    P1 = i;  
    ID = 0; //Reset P3.0  
    RW = 0; //Reset P3.7  
    E = 1; //Set P3.4  
    delay(1);  
    E = 0; //Reset P3.4  
}  
//-----  
void Wdata(char i)  
{  
    P1 = i;  
    ID = 1; //Set P3.0  
    RW = 0; //Reset P3.7  
    E = 1; //Set P3.4  
    delay(1);  
    E = 0; //Reset P3.4  
}  
//-----
```

## Quality Information

Test Item	Content of Test	Test Condition	Note
High Temperature storage	Endurance test applying the high storage temperature for a long time.	+80°C , 200 Hrs.	2
Low Temperature storage	Endurance test applying the low storage temperature for a long time.	-30°C , 200 Hrs.	1,2
High Temperature Operation	Endurance test applying the electric stress (voltage & current) and the high thermal stress for a long time.	+70°C , 200 Hrs.	2
Low Temperature Operation	Endurance test applying the electric stress (voltage & current) and the low thermal stress for a long time.	-20°C , 200 Hrs.	1,2
High Temperature / Humidity Operation	Endurance test applying the electric stress (voltage & current) and the high thermal with high humidity stress for a long time.	+60°C , 90% RH , 96 Hrs.	1,2
Thermal Shock resistance	Endurance test applying the electric stress (voltage & current) during a cycle of low and high thermal stress.	-20°C, 30min -> 25°C, 5min -> 70°C, 30min = 1 cycle For 10 cycles	
Vibration test	Endurance test applying vibration to simulate transportation and use.	10-55Hz, 1.5mm amplitude. 60 sec in each of 3 directions X,Y,Z For 15 minutes	3
Static electricity test	Endurance test applying electric static discharge.	V <sub>s</sub> =±800V, R <sub>s</sub> =330Ω, C <sub>s</sub> =150pF 10 Times	

**Note 1:** No condensation to be observed.

**Note 2:** Conducted after 4 hours of storage at 25°C, 0%RH.

**Note 3:** Test performed on product itself, not inside a container.

## Precautions for using LCDs/LCMs

See Precautions at [www.newhavendisplay.com/specs/precautions.pdf](http://www.newhavendisplay.com/specs/precautions.pdf)

## Warranty Information and Terms & Conditions

[http://www.newhavendisplay.com/index.php?main\\_page=terms](http://www.newhavendisplay.com/index.php?main_page=terms)