

5A Low Dropout Positive Regulator

FEATURES

- Dropout Voltage 1.5V at 5A Output Current.
- Fast Transient Response.
- Extremely Tight Line and Load Regulation.
- Current Limiting and Thermal Protection.
- Adjustable Output Voltage or Fixed 1.5V, 1.8V, 2.5V, 3.3V.
- Standard 3-Pin Power Packages.

APPLICATIONS

- Mother Board I/O Power Supplies.
- Microprocessor Power Supplies.
- High Current Regulator.
- Post Regulator for Switching Supply.

DESCRIPTION

The AIC1084 is a low dropout three terminal regulator with 5A output current capability. The output voltage is adjustable with the use of a resistor divider or fixed 1.5V, 1.8V, 2.5V and 3.3V. Dropout voltage is guaranteed to be at maximum of 1.5V with the maximum output current. Its low dropout voltage and fast transient response make it ideal for low voltage microprocessor applications. Current limit and thermal protection provide protection against any overload condition that would create excessive junction temperatures.

TYPICAL APPLICATION CIRCUIT

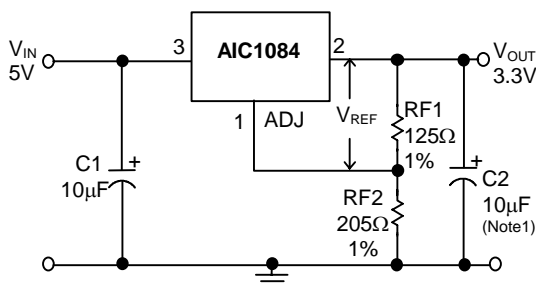

Adjustable Voltage Regulator

$$V_{REF} = V_{OUT} - V_{ADJ} = 1.25V \text{ (typ.)}$$

$$V_{OUT} = V_{REF} \times (1 + RF2/RF1) + I_{ADJ} \times RF2$$

$$I_{ADJ} = 55\mu A \text{ (typ.)}$$

- (1) C1 needed if device is far away from filter capacitors.
- (2) C2 required for stability.

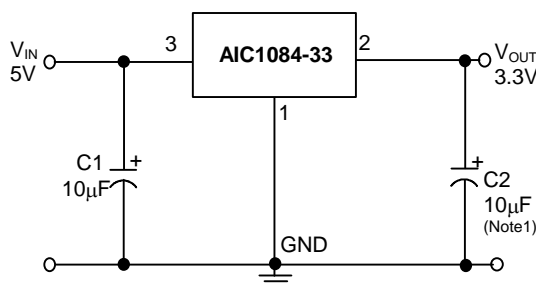

Fixed Voltage Regulator

ORDERING INFORMATION

AIC1084-XXXXXX

PACKING TYPE
 TB: TUBE
 TR: TAPING & REEL

 PACKAGING TYPE
 E: TO-252
 M: TO-263
 T: TO-220

 C: COMMERCIAL
 P: LEAD FREE COMMERCIAL
 G: GREEN PACKAGE

 OUTPUT VOLTAGE
 DEFAULT: ADJUSTABLE
 15: 1.5V
 18: 1.8V
 25: 2.5V
 33: 3.3V

(1.5V version is available under request)

Example: AIC1084-18CETR
 → 1.8V version in TO-252 Package & Taping & Reel Packing Type

Example: AIC1084-18PMTR
 → 1.8V version in TO-263 Lead Free Package & Taping & Reel Packing Type

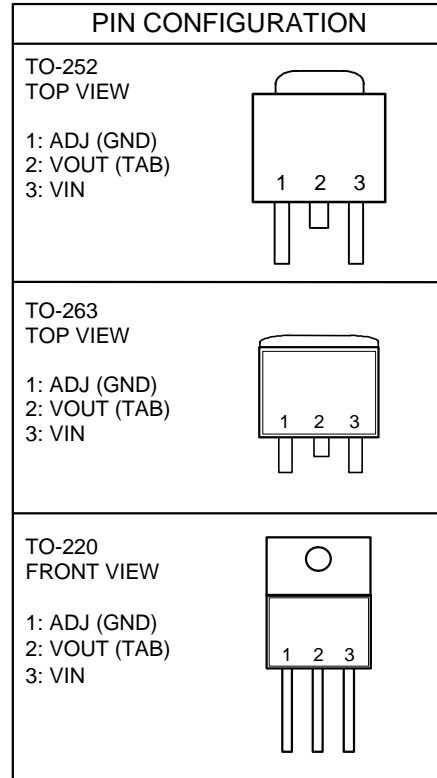

ABSOLUTE MAXIMUM RATINGS

VIN pin to ADJ/GND pin7V
Ambient Temperature Range-40°C to 85°C
Maximum Junction Temperature125°C
Storage Temperature Range-65°C ~ 150°C
Lead Temperature (Soldering) 10 sec.260°C
Thermal Resistance Junction to Case	TO-252.....12.5°C/W
	TO-263, TO-220.....3°C/W
Thermal Resistance Junction to Ambient	TO-252.....100°C/W
(Assume no ambient airflow, no heatsink)	TO-263.....60°C/W
	TO-220.....50°C/W

Absolute Maximum Ratings are those values beyond which the life of a device may be impaired.

■ TEST CIRCUIT

Refer to TYPICAL APPLICATION CIRCUIT.

■ ELECTRICAL CHARACTERISTICS

($V_{IN}=5V$, $T_J=25^{\circ}C$, $I_O=10mA$, unless otherwise specified) (Note2)

PARAMETER	TEST CONDITIONS	MIN.	TYP.	MAX.	UNIT
Reference Voltage	AIC1084 (ADJ)	1.225	1.25	1.275	V
Output Voltage	AIC1084-15, $V_{IN}=5V$	1.47	1.50	1.53	V
	AIC1084-18, $V_{IN}=5V$	1.76	1.80	1.84	
	AIC1084-25, $V_{IN}=5V$	2.45	2.50	2.55	
	AIC1084-33, $V_{IN}=5V$	3.23	3.30	3.37	
Line Regulation	ADJ : $2.75V \leq V_{IN} \leq 7V$ $V_{OUT}=1.25V$		0.015	0.2	%
	Fix : $V_{OUT}+1.5V \leq V_{IN} \leq 7V$				
Load Regulation	$10mA < I_O < 5A$			0.6	%
Dropout Voltage	$\Delta V_{OUT}, \Delta V_{REF}=1\%$ $10mA \leq I_O \leq 5A$		1.4	1.5	V
Current Limit		5	6		A
GND Current (Fix)	$V_{OUT}+1.5V \leq V_{IN} \leq 7V$		11.5	14	mA
Adjusted Pin Current	$2.75V \leq V_{IN} \leq 7V$		55	120	μA
Adjusted Pin Current Change (ΔI_{ADJ})	$2.75V \leq V_{IN} \leq 7V$		0.2	5	μA
Temperature Stability	$I_O=0.5A$		0.5		%
Minimum Load Current			5	10	mA
RMS Output Noise (% of V_{OUT})	$10Hz \leq f \leq 10KHz$		0.003		%
Ripple Rejection Ratio	120Hz input ripple $C_{OUT}=25\mu F$ $(V_{IN}-V_{OUT})=3V$	60	72		dB
Thermal Shutdown Temperature	Note 3		165		$^{\circ}C$

Note 1: To avoid output oscillation, aluminum electrolytic output capacitor is recommended and ceramic capacitor is not suggested.

Note 2: Specifications are production tested at $T_A=25^{\circ}C$. Specifications over the $-40^{\circ}C$ to $85^{\circ}C$ operating temperature range are assured by design, characterization and correlation with Statistical Quality Controls (SQC).

Note 3: Guarantee by design.

TYPICAL PERFORMANCE CHARACTERISTICS

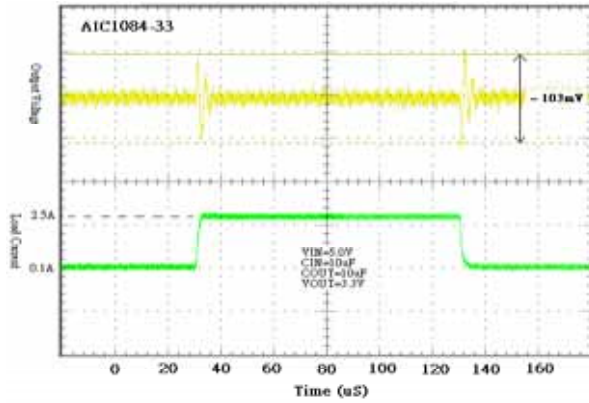

Fig. 1 Load Transient Response

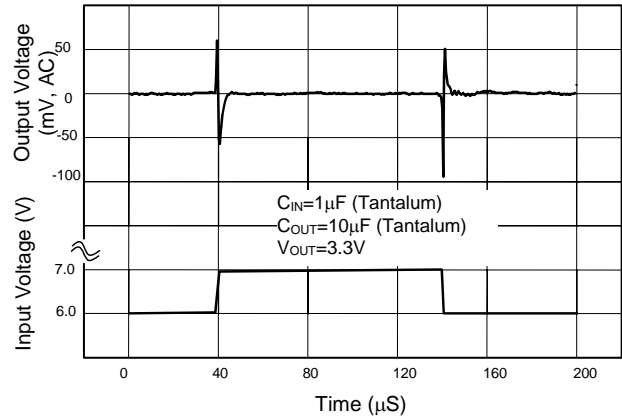

Fig. 2 Line Transient Response

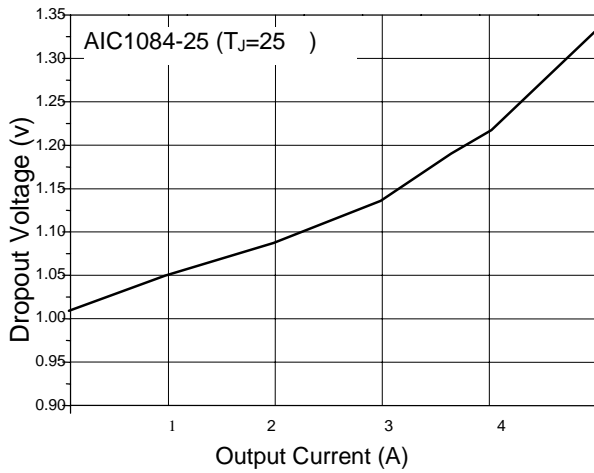

Fig. 3 Dropout Voltage ($V_{OUT}=2.5$)

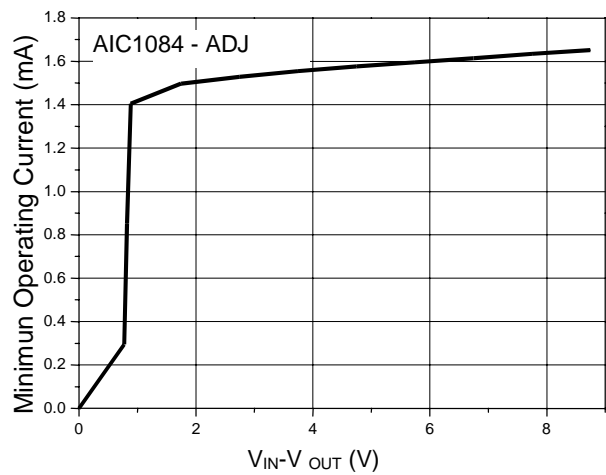

Fig. 4 Minimum Operating Current

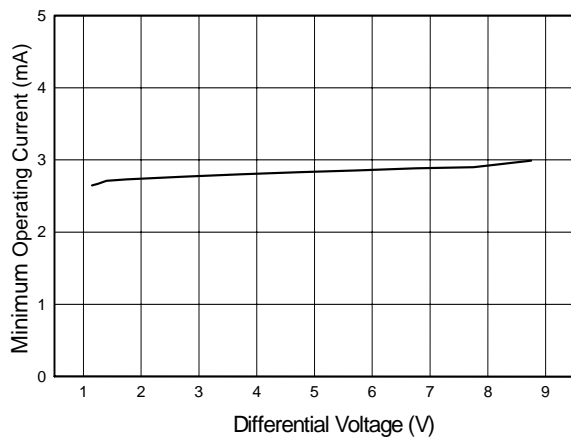

Fig. 5 Minimum Operating Current

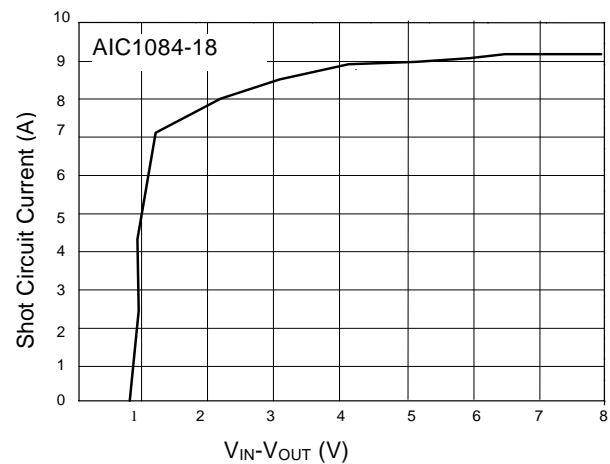

Fig. 6 AIC1084 (1.8) Short Circuit Current

■ **TYPICAL PERFORMANCE CHARACTERISTICS** (Continued)

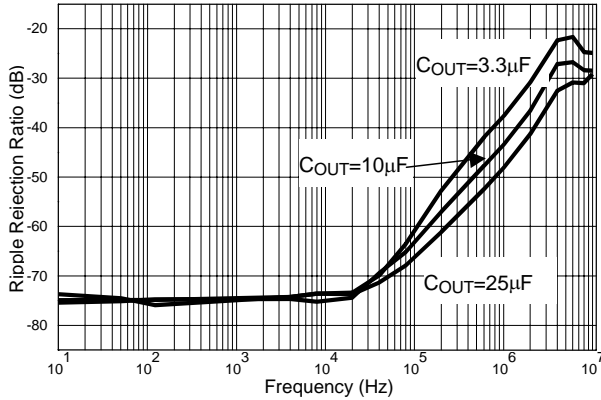
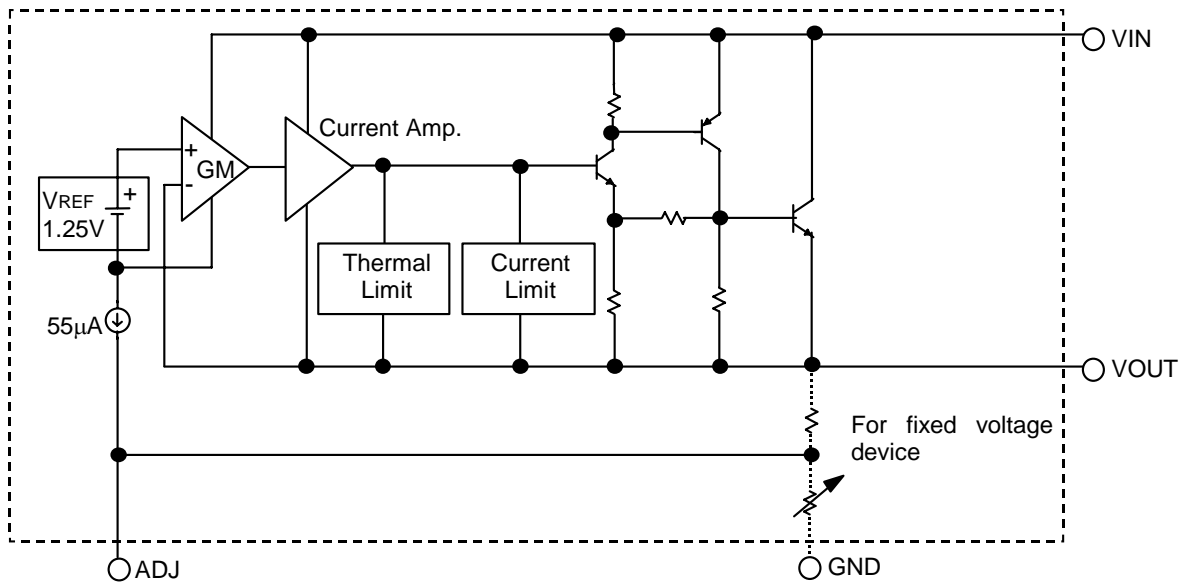

Fig. 7 AIC1084 (ADJ.) Ripple Rejection

■ **BLOCK DIAGRAM**



■ **PIN DESCRIPTIONS**

- ADJ PIN - Providing V_{REF}=1.25V (typ.) for adjustable V_{OUT}. V_{REF}=V_{OUT}-V_{ADJ} and I_{ADJ}=55μA (typ.) (GND PIN- Power ground.)
- VOUT PIN - Adjustable output voltage.
- VIN PIN - Power Input.

APPLICATION INFORMATION

INPUT-OUTPUT CAPACITORS

Linear regulators require input and output capacitors to maintain stability. Input capacitor at 10 μ F with a 10 μ F aluminum electrolytic output capacitor is recommended.

POWER DISSIPATION

The AIC1084 obtains thermal-limiting circuitry, which is designed to protect the device against overload condition. For continuous load condition, maximum rating of junction temperature must not be exceeded. It is important to pay more attention in thermal resistance. It includes junction to case, junction to ambient. The maximum power dissipation of AIC1084 depends on the thermal resistance of its case and circuit board, the temperature difference between the die junction and ambient air, and the rate of airflow. The rate of temperature rise is greatly affected by the

mounting pad configuration on the PCB, the board material, and the ambient temperature. When the IC mounting with good thermal conductivity is used, the junction temperature will be low even when large power dissipation applies.

The power dissipation across the device is

$$P = I_{OUT} (V_{IN} - V_{OUT})$$

The maximum power dissipation is:

$$P_{MAX} = \frac{(T_{J-max} - T_A)}{R\theta_{JA}}$$

Where T_{J-max} is the maximum allowable junction temperature (125°C), and T_A is the ambient temperature suitable in application.

As a general rule, the lower temperature is, the better reliability of the device is. So the PCB mounting pad should provide maximum thermal conductivity to maintain low device temperature.

APPLICATION EXAMPLES

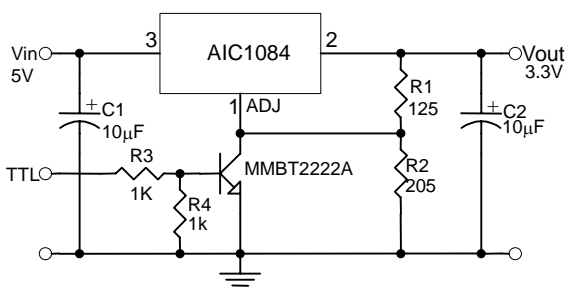
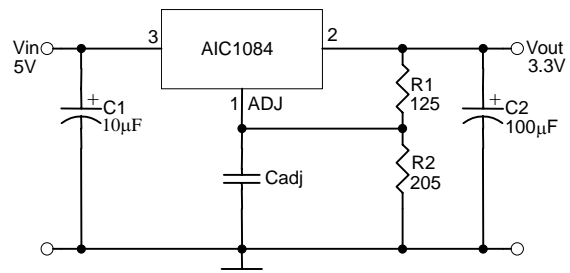

Fig. 8 $V_{OUT}=3.3V$ with Shutdown



* Cadj can improve ripple rejection

Fig. 9 Improving Ripple Rejection

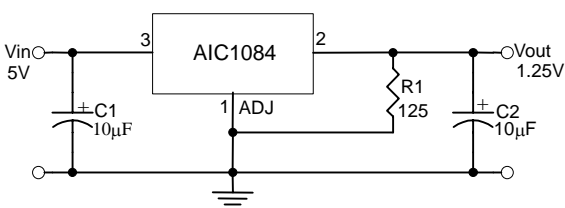

Fig. 10 $V_{OUT}=1.25V$ Application Circuit

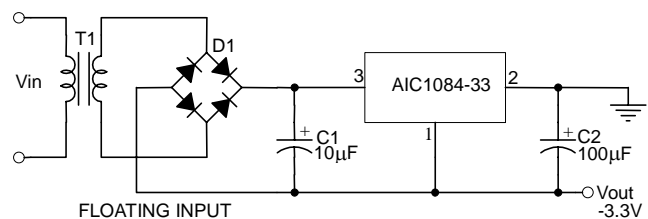
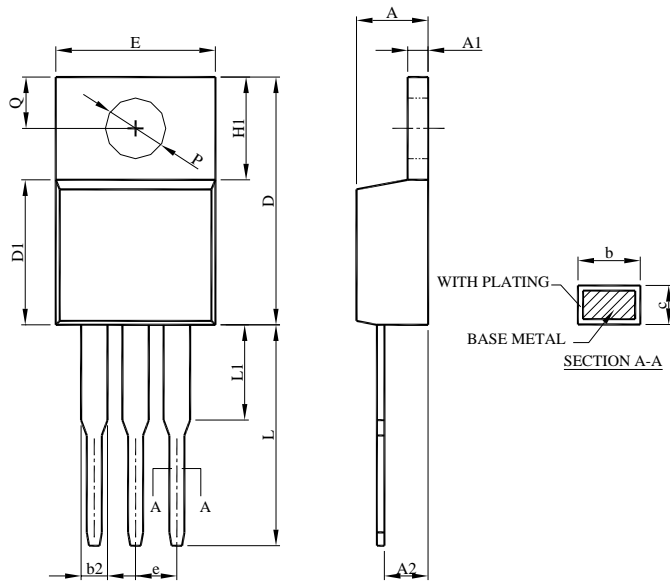

Fig. 11 Low Dropout Negative Supply

■ PHYSICAL DIMENSIONS

- TO-220 (unit: mm)



SYMBOL	TO-220	
	MILLIMETERS	
	MIN.	MAX.
A	3.56	4.82
A1	0.51	1.39
A2	2.04	2.92
b	0.38	1.01
b2	1.15	1.77
c	0.35	0.61
D	14.23	16.51
D1	8.38	9.02
E	9.66	10.66
e	2.54 BSC	
H1	5.85	6.85
L	12.70	14.73
L1	--	6.35
P	3.54	4.08
Q	2.54	3.42

Note:

- 1.Refer to JEDEC TO-220AB.
- 2.Controlling dimension is millimeter, converted inch dimensions are not necessarily exact.

● TO-252 (unit: mm)

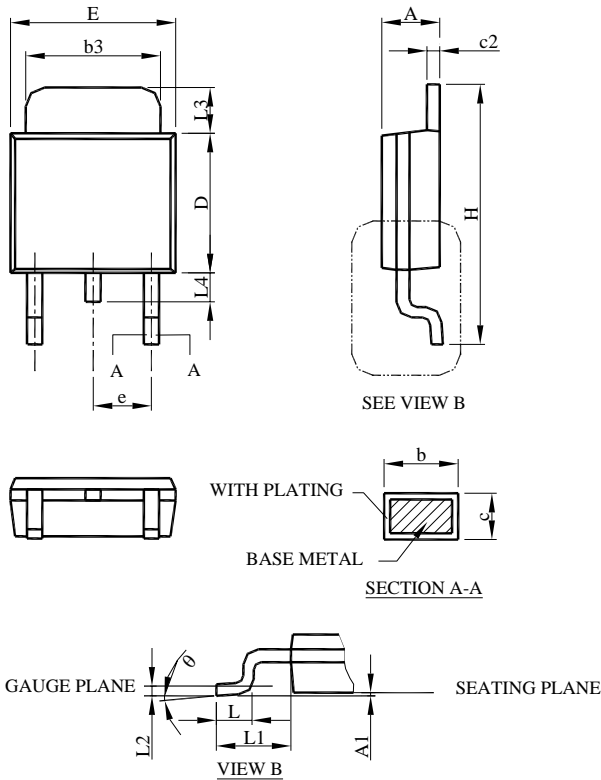

SYMBOL	TO-252-3L	
	MILLIMETERS	
	MIN.	MAX.
A	2.19	2.38
A1	0.00	0.13
b	0.64	0.89
b3	4.95	5.46
c	0.46	0.61
c2	0.46	0.89
D	5.33	6.22
E	6.35	6.73
e	2.28 BSC	
H	9.40	10.41
L	1.40	1.78
L1	2.67 REF	
L2	0.51 BSC	
L3	0.89	2.03
L4	--	1.02
θ	0°	8°

Note:

- 1.Refer to JEDEC TO-252AA and AB.
- 2.Dimension D and E do not include mold flash, protrusions or gate burrs. Mold flash, protrusion or gate burrs shall not exceed 6 mil per side.
- 3.Controlling dimension is millimeter, converted inch dimensions are not necessarily exact.

● TO-263 (unit: mm)

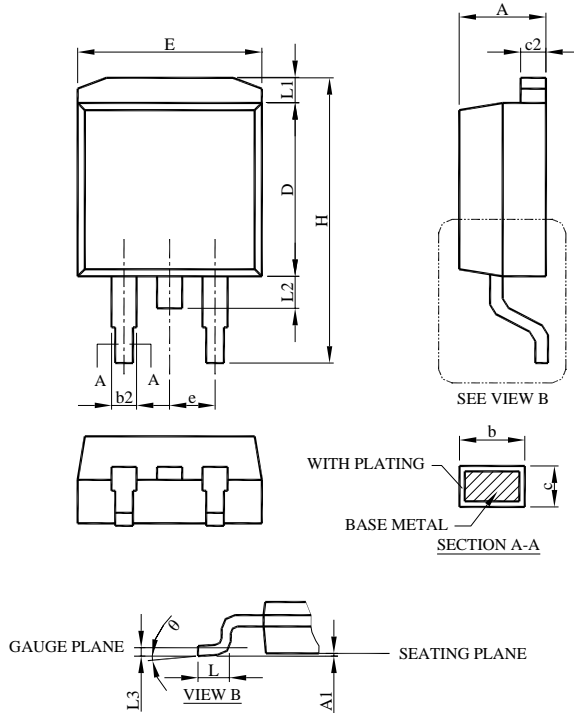

SYMBOL	TO-263-3L	
	MILLIMETERS	
	MIN.	MAX.
A	4.06	4.83
A1	0.00	0.25
b	0.51	0.99
b2	1.14	1.78
c	0.38	0.74
c2	1.14	1.65
D	8.38	9.65
E	9.65	10.67
e	2.54 BSC	
H	14.61	15.88
L	1.78	2.79
L1	--	1.68
L2	--	1.78
L3	0.25 BSC	
θ	0°	8°

Note:
 1.Refer to JEDEC TO-263AB.
 2.Controlling dimension is millimeter, converted inch dimensions are not necessarily exact.

Note:

Information provided by AIC is believed to be accurate and reliable. However, we cannot assume responsibility for use of any circuitry other than circuitry entirely embodied in an AIC product; nor for any infringement of patents or other rights of third parties that may result from its use. We reserve the right to change the circuitry and specifications without notice.

Life Support Policy: AIC does not authorize any AIC product for use in life support devices and/or systems. Life support devices or systems are devices or systems which, (i) are intended for surgical implant into the body or (ii) support or sustain life, and whose failure to perform, when properly used in accordance with instructions for use provided in the labeling, can be reasonably expected to result in a significant injury to the user.