



M.S.KENNEDY CORP.

ULTRA HIGH SLEW RATE HIGH VOLTAGE AMPLIFIER

611

4707 Dey Road Liverpool, N.Y. 13088

(315) 701-6751

FEATURES:

- Low Quiescent Current - $\pm 25\text{mA}$ for High Voltage Stage
- 110V Peak to Peak Output Voltage Swing
- Slew Rate - $5000\text{V}/\mu\text{S}$ @ 100Vpp
- Small Signal Rise Time - 6nS Typical
- Power Output Frequency - 7 MHz Typical
- Output Current - 150mA Peak
- Adjustable VHV Power Supply Minimizes Power Dissipation
- Compact Package Offers Superior Power Dissipation

MIL-PRF-38534 CERTIFIED

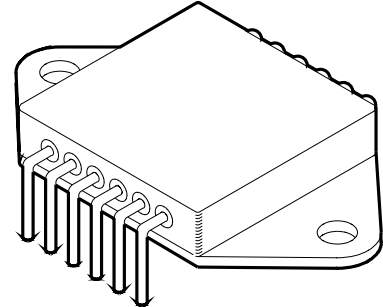

DESCRIPTION:

The MSK 611 is a high voltage ultra high slew rate amplifier designed to provide large voltage swings in wideband systems. The true inverting op-amp topology employed in the MSK 611 provides excellent D.C. specifications such as input offset voltage and input bias current. These attributes are important in amplifiers that will be used in high gain configurations since the input error voltages will be multiplied by the system gain. The MSK 611 achieves impressive slew rate specifications by employing a feed forward A.C. path through the amplifier, however, the device is internally configured in inverting mode to utilize this benefit. Internal compensation for gains of $-5\text{V}/\text{V}$ or greater keeps the MSK 611 stable in this range. The MSK 611 is packaged in a space efficient, hermetically sealed, 12 pin power dual in line package that has a high thermal conductivity for efficient device cooling.

EQUIVALENT SCHEMATIC

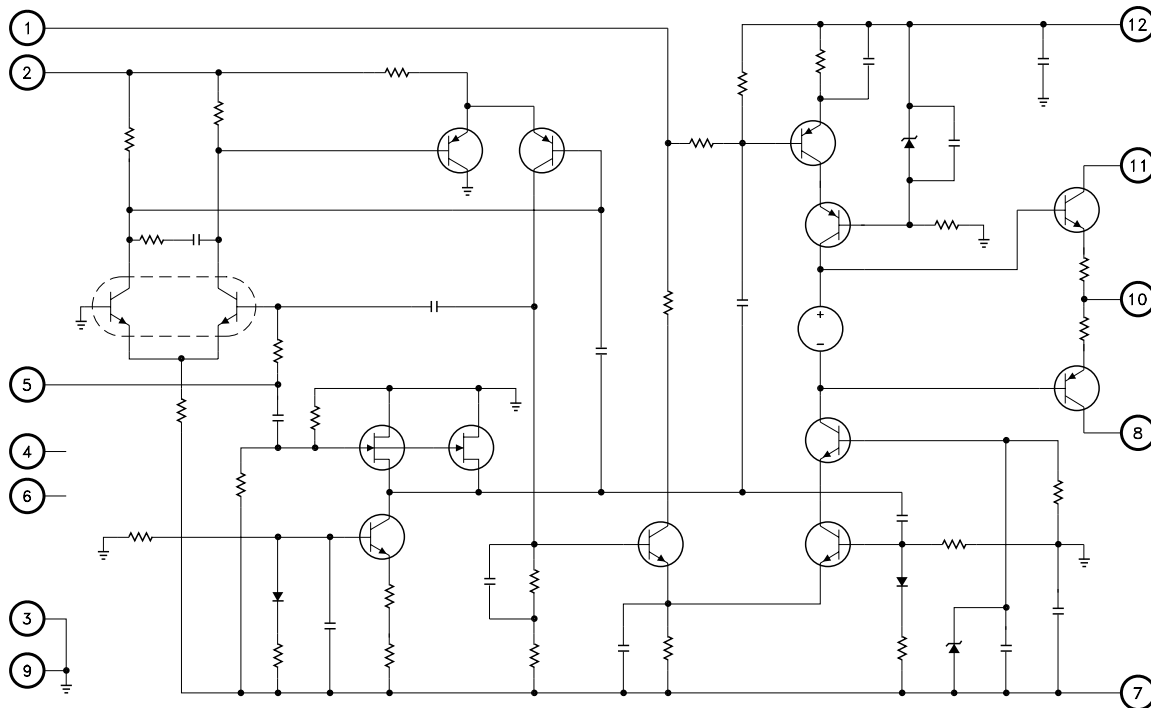

TYPICAL APPLICATIONS

- Wideband High Voltage Amplifier
- High Resolution CRT Monitor
- Ultra High Performance Video Processing
- CRT Beam Intensity Control
- Varactor Tuned VCO Driver
- Automatic Test Equipment

PIN-OUT INFORMATION

1	COMP	12	+VHV
2	+VCC	11	+VSC
3	GROUND	10	OUTPUT
4	N/C	9	CASE/GROUND
5	-INPUT	8	-VSC
6	N/C	7	-VCC

ABSOLUTE MAXIMUM RATINGS ^⑧

+V _{HV} , +V _{SC}	Supply Voltage	+130VDC	T _{ST}	Storage Temperature Range	-65°C to +150°C
-V _{SC}	Supply Voltage	-18VDC	T _{LD}	Lead Temperature Range	300°C
±V _{IN}	Input Voltage Range	±V _{CC}		(10 Seconds)	
±V _{CC}	Supply Voltage (Input Stage)	±18VDC	T _C	Case Operating Temperature	
θ _{JC}	Thermal Resistance	30°C/W		MSK611	-40°C to +125°C
	(Output Devices)			MSK611B	-55°C to +125°C
			T _J	Junction Temperature	150°C

ELECTRICAL SPECIFICATIONS

Parameter	Test Conditions ^①	Group A Subgroup	MSK 611B			MSK 611			Units	
			Min.	Typ.	Max.	Min.	Typ.	Max.		
STATIC										
Quiescent Current	V _{IN} = 0	1,2,3	@ +V _{CC}	-	1.0	2.0	-	1.0	2.0	mA
			@ -V _{CC}	-	30	40	-	30	45	mA
			^⑦ @ +V _{HV}	-	25	40	-	25	45	mA
			@ -V _{SC}	-	11	15	-	11	20	mA
Input Offset Voltage	V _{IN} = 0	1	-	±1.0	±5.0	-	±1.0	±10	mV	
		2,3	-	±2.0	±10.0	-	±2.0	-	mV	
Input Bias Current		1	-	50	250	-	50	500	nA	
		2,3	-	100	500	-	100	-	nA	
Input Offset Voltage Drift ^②	V _{IN} = 0	2,3	-	±10	±50	-	±10	-	μV/°C	
Power Supply Range ^②	±V _{CC}	-	±12	±15	±18	±12	±15	±18	V	
	+V _{HV} , +V _{SC}	-	50	120	130	50	120	130	V	
	-V _{SC}	-	-18	-15	0	-18	-15	0	V	
DYNAMIC CHARACTERISTICS										
Output Voltage Swing ^⑥	f = 1KHz	4	100	110	-	100	110	-	V _{pp}	
Peak Output Current ^②	f = 1KHz	4	±125	±150	-	±125	±150	-	mA	
Full Power Output Frequency ^②	V _O = 100V _{pp}	4	5	7	-	4	7	-	MHz	
Unity Gain Bandwidth ^②	V _O = 1V _{pp}	-	-	150	-	-	150	-	MHz	
Slew Rate	V _O = 100V _{pp}	4	5000	5500	-	4500	5500	-	V/μS	
Voltage Gain ^②	f = 1KHz	4	80	100	-	80	100	-	dB	
Settling Time to 1% ^②	A _v = -10V/V V _O = 50V _{pp}	-	-	100	-	-	100	-	nS	
Settling Time to 0.1% ^②	A _v = -10V/V V _O = 50V _{pp}	-	-	250	-	-	250	-	nS	

NOTES:

- ① Unless otherwise specified, ±V_{CC} = ±15VDC, +V_{HV} = +V_{SC} = +120VDC, -V_{SC} = -15VDC, C_L = 5pF (probe capacitance) and A_v = 10V/V.
- ② This parameter is guaranteed by design but not tested. Typical parameters are representative of actual device performance but are for reference only.
- ③ Industrial grade devices shall be tested to subgroups 1 and 4 unless otherwise specified.
- ④ Military grade devices ('B' suffix) shall be 100% tested to subgroups 1,2,3 and 4.
- ⑤ Subgroup 1,4 T_C = +25°C
Subgroup 2,5 T_J = +125°C
Subgroup 3,6 T_A = -55°C
- ⑥ The output voltage swing is typically within 8 volts of each V_{SC} supply setting.
- ⑦ Includes +V_{SC} quiescent current.
- ⑧ Continuous operation at or above absolute maximum ratings may adversely effect the device performance and/or life cycle.

APPLICATION NOTES

FEED FORWARD TOPOLOGY

The MSK 611 employs a circuit topology known as "feed forward". This inverting configuration allows the user to realize the excellent D.C. input characteristics of a differential amplifier without losing system bandwidth. The incoming signal is split at the input into its A.C. and D.C. component. The D.C. component is allowed to run through the differential amplifier where any common mode noise is rejected. The A.C. component is "fed forward" to the output section through a very high speed linear amplifier where it is mixed back together with the D.C. component. The result is a composite amplifier with most of the benefits of a differential amplifier without the loss in system bandwidth.

INTERNAL COMPENSATION

Since the MSK 611 is a high voltage amplifier, it is commonly used in circuits employing large gains. Therefore, the internal compensation was chosen for gains of $-5V/V$ or greater. In circuits running at gains of less than $-5V/V$, the user can further compensate the device by adding compensation networks at the input or feedback node. Pin 1 (comp) should be bypassed with a $0.1\mu F$ ceramic capacitor to $+V_{HV}$ for all applications.

HIGH VOLTAGE SUPPLIES

The positive and negative high voltage supplies on the MSK 611 can be adjusted to reduce power dissipation. The output of the MSK 611 will typically swing to within 8V of either output voltage power supply rail. Therefore, if the system in question only needs the output of the amplifier to swing 0 to 40V peak, the power supply rails could be set to $-15V$ and $+50V$ safely. For best performance, the minimum value of $+V_{HV}$ should be $+50V_{DC}$. The $-V_{SC}$ pin may be directly connected to ground if the output does not need to swing through zero volts. The high voltage and low voltage power supplies should be decoupled as shown in Figure 1.

TRANSITION TIMES

Transition time optimization of the MSK 611 follows the same basic rules as most any other amplifier. Best transition times will be realized with minimum load capacitance, minimum external feedback resistance and lowest circuit gain. Transition times will degrade if the output is driven too close to either supply rail. Feedback and input resistor values will affect transition time as well. See Figure 1 and Table 1 for recommended component values.

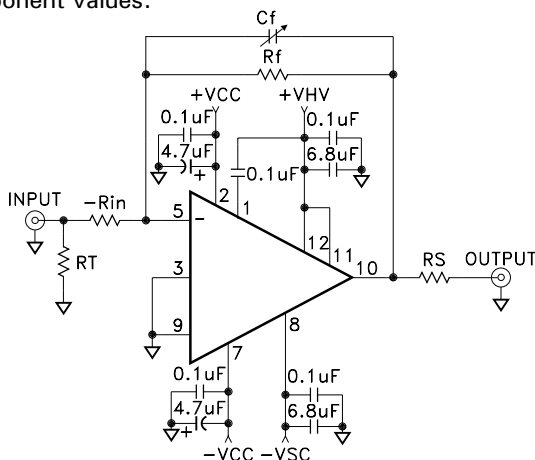

Figure 1

VOLTAGE GAIN	$-R_{IN}$	R_F	C_F
$-10V/V$	402Ω	$4.02K\Omega$	$0.25-2pF$
$-20V/V$	301Ω	$6.04K\Omega$	N/A
$-50V/V$	100Ω	$5K\Omega$	N/A

Table 1

CURRENT LIMIT

Figure 2 is an active short circuit protection scheme for the MSK 611. The following formula may be used for setting current limit:

$$\text{Current Limit} \approx 0.6V / R_{sc}$$

R_{BASE} must be selected based on the value of $+V_{HV}$ and $-V_{CC}$ as follows:

$$R_{BASE} = ((+V_{HV} - (-V_{CC})) - 1.2V) / 4mA$$

This formula guarantees that Q2 and Q4 will always have sufficient base current to be in operation. This circuit can be made tolerant of high frequency output current spikes with the addition of C_{sc} . The corresponding time constant would be:

$$T = (R_{sc})(C_{sc})$$

A common value for C_{sc} is approximately $1000pF$. If current limit is unnecessary, short pin 7 to pin 8 and pin 11 to pin 12. Pin 8 can be tied to ground if swing through zero is not desired.

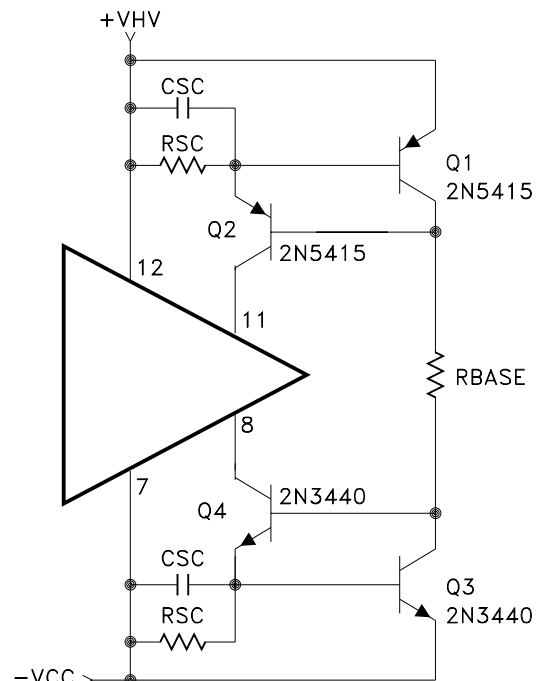
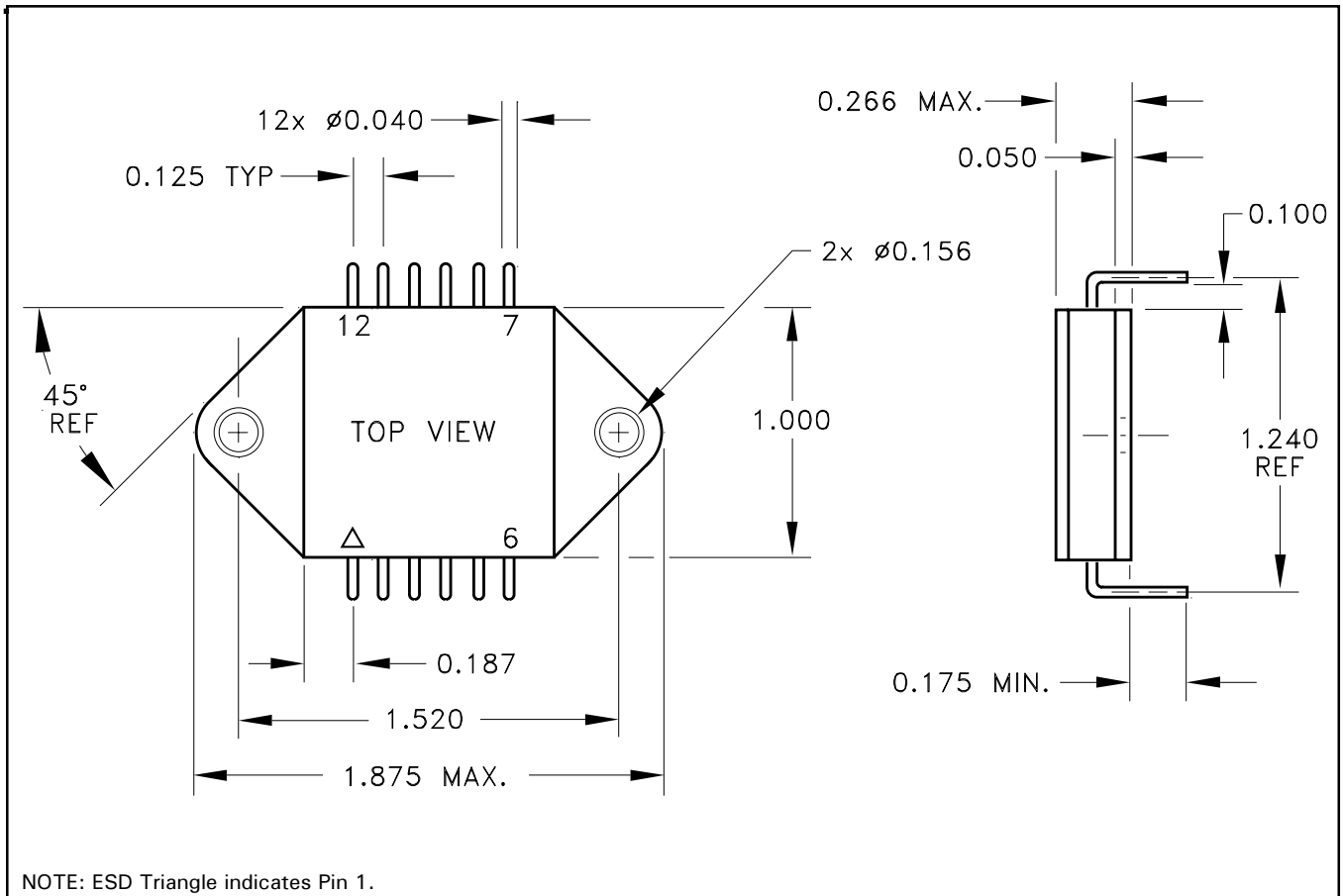

Figure 2

MECHANICAL SPECIFICATIONS



ALL DIMENSIONS ARE ± 0.010 INCHES UNLESS OTHERWISE LABELED

ORDERING INFORMATION

Part Number	Screening Level
MSK611	Industrial
MSK611B	Mil-PRF-38534 CLASS H

M.S. Kennedy Corp.
 4707 Dey Road, Liverpool, New York 13088
 Phone (315) 701-6751
 FAX (315) 701-6752
 www.mskennedy.com

The information contained herein is believed to be accurate at the time of printing. MSK reserves the right to make changes to its products or specifications without notice, however, and assumes no liability for the use of its products. Please visit our website for the most recent version of this datasheet.