

HIGH CURRENT ADJUSTABLE VOLTAGE REGULATOR BL317B

DESCRIPTION

The BL317B is an adjustable 3-terminal positive voltage regulator, designed to supply more than 1.5A of output current with voltage adjustable from 1.3V ~ 37V.

FEATURES

- Output current up to 1.5A
- Output voltage adjustable from 1.3V to 37V
- Internal short circuit protection
- Internal over temperature protection
- Safe-Area compensation for output transistor

APPLICATIONS

- PC Motherboard
- LCD Monitor
- Graphic Card
- DVD Player
- Network Interface Card/Switch
- Telecom Equipment
- Printer and other Peripheral Equipment

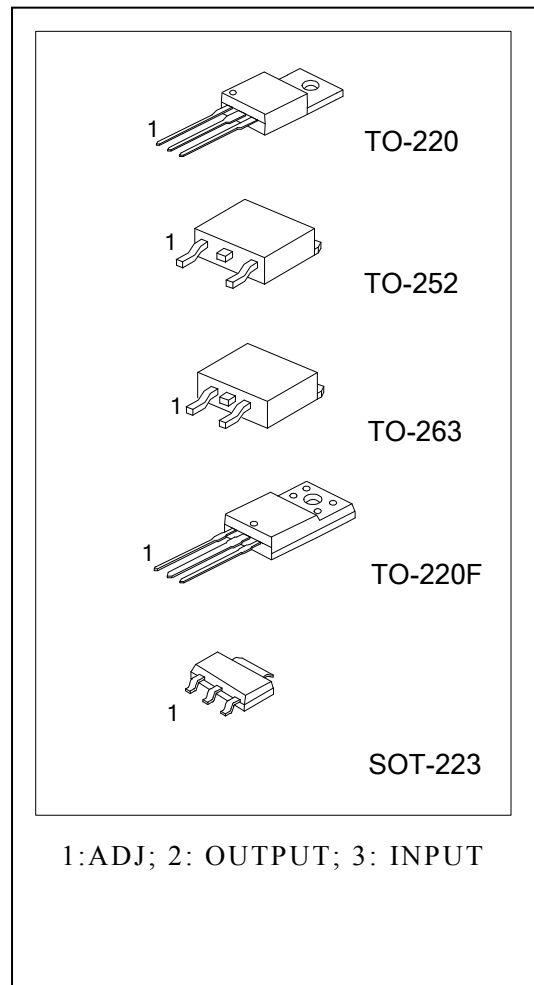

ORDERING INFORMATION

Device	Package	Shipping
BL317BT	TO-220	Tube
BL317BF	TO-220F	Tube
BL317BY-B	TO-252	2500pcs/Reel
BL317BY-T	TO-252	80pcs/Tube
BL317BK	TO-263-2L	Reel
BL317BS	SOT-223	Reel

BLOCK DIAGRAM

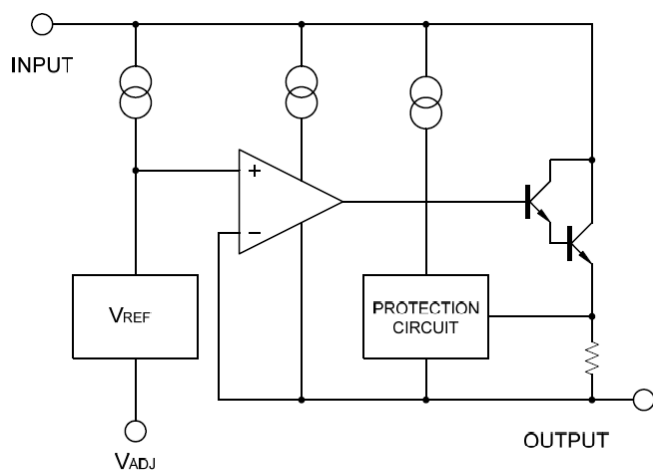

ABSOLUTE MAXIMUM RATINGS (Ta=25°C) *

Characteristic	Symbol	Min.	Max.	Unit
Input - Output Voltage Difference	Vin-Vout		40	V
Power Dissipation	Pd	Internal limited		
Operating Temperature Range	TOPR	0	125	°C
Storage temperature	Ts	-65	150	°C
Lead temperature (soldering, 10sec)	TLEAD		260	°C

*: Absolute maximum ratings are stress ratings only and functional device operation is not implied. The device could be damaged beyond Absolute maximum ratings.

ELECTRICAL CHARACTERISTICS

($V_I - V_O = 5V, 0^\circ C < T_j < 125^\circ C, I_O = 500mA, I_{MAX} = 1.5A, P_{MAX} = 20W$, unless otherwise specified)

Parameter	Symbol	Test conditions	Min	Typ	Max	Unit	
Line Regulation	ΔVO	$T_a = 25^\circ C, 3V \leq V_I - V_O \leq 40V$		0.01	0.04	% / V	
		$T_a = 0 - 125^\circ C, 3V \leq V_I - V_O \leq 40V$		0.02	0.07		
Load Regulation	ΔVO	$T_a = 25^\circ C$	$10mA \leq I_O \leq I_{MAX}$	$VO \leq 6V$	18	25	mV
		$VO \leq 5V$		0.4	0.5	% / VO	
		$T_a = 0 - 125^\circ C$	$10mA \leq I_O \leq I_{MAX}$	$VO \leq 5V$	40	70	mV
		$VO \leq 6V$		0.8	1.5	% / VO	
Adjustable Pin current	IADJ			46	100	μA	
Adjustable Pin Current Change	$\Delta IADJ$	$2.5V \leq V_I - V_O \leq 40V,$ $10mA \leq I_O \leq I_{MAX}, PD \leq P_{MAX}$		2.0	5	μA	
Reference Voltage	VREF	$3V \leq V_I - V_O \leq 40V,$ $10mA \leq I_O \leq I_{MAX}, PD \leq P_{MAX}$	1.20	1.25	1.30	V	
Temperature Stability	STT			0.7		% / VO	
Minimum Load Current for regulation	IL(MIN)	$V_I - V_O = 40V$		3.5	10	mA	
Maximum output Current	IO(MAX)	$V_I - V_O \leq 15V, PD \leq P_{MAX}$	1.5	2.2		A	
		$V_I - V_O \leq 40V, PD \leq P_{MAX},$ $T_a = 25^\circ C$	0.15	0.4			
RMS Noise v.s. % of Vout	eN	$T_A = 25^\circ C, 10HZ \leq f \leq 10KHZ$		0.003	0.01	% / VO	
Ripple Rejection	RR	$VO = 10V, f = 120HZ, CADJ = 0$		60		dB	
		$VO = 10V, f = 120HZ, CADJ = 10\mu F$	66	75			
Long-term Stability, T _J =THIGH	ST	$T_A = 25^\circ C, 1000 \text{ hr}$		0.3	1	%	

Note: Testing with low duty pulse should be used to avoid heating effect.

THERMAL DATA

Parameter		Symbol	RATING	UNITS
Junction-to-Ambient	TO-252	θJA	112	°C/W
	TO-220		54	
	TO-220F		44	
	TO-263		64	
	SOT-223		165	
Junction-to-Case	TO-252	θJC	12	°C/W
	TO-220		5	
	TO-220F		5	
	TO-263		5	
	SOT-223		23	

APPLICATION CIRCUIT

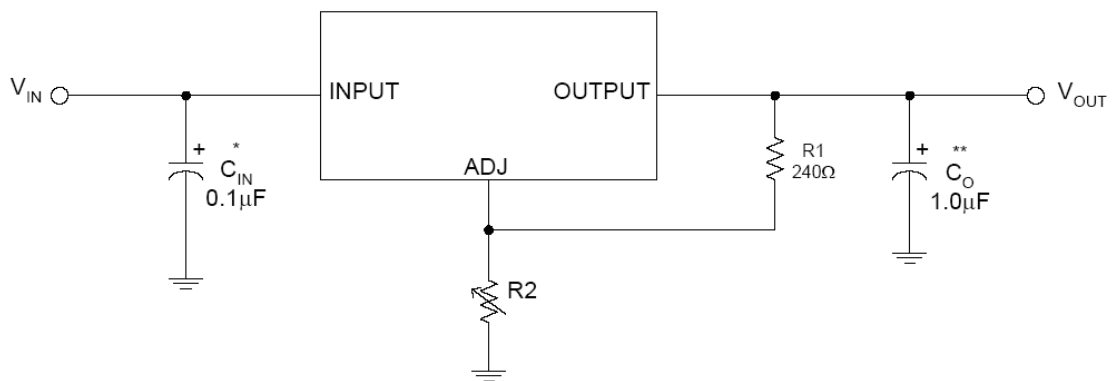

* = C_{IN} is required if the regulator is located near power supply filter.

** = C_O is needed for stability and it improves transient response.

$$V_{OUT} = V_{REF} \times (1 + R2/R1) + I_{ADJ} \times R2$$

Since I_{ADJ} is controlled to less than 100μA, the error associated with this term is negligible in most applications.

CHARACTERISTICS CURVES

Fig.1. Load Regulation vs temperature

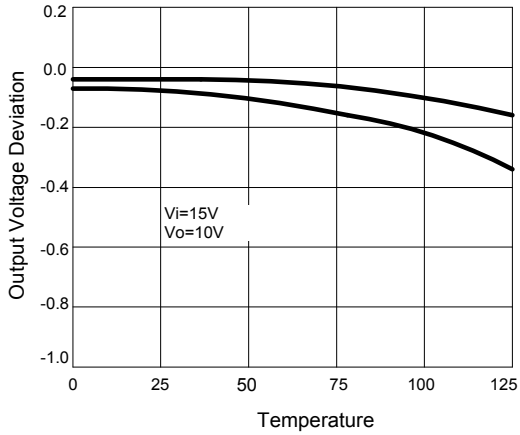

Fig.2 Adjustment Current vs Temperature

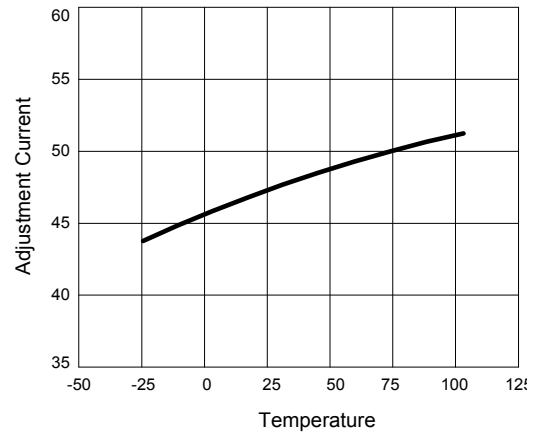

Fig.3. Dropout Voltage vs Input-Output Voltage Difference

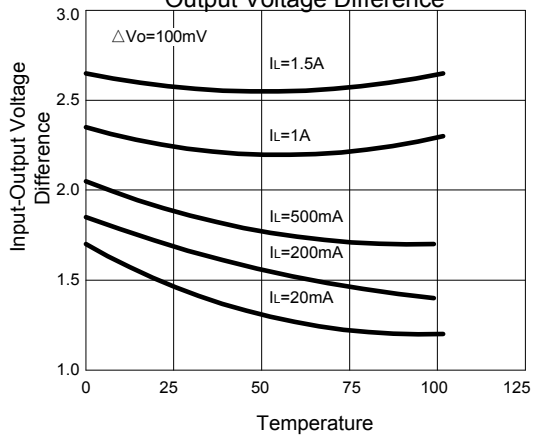
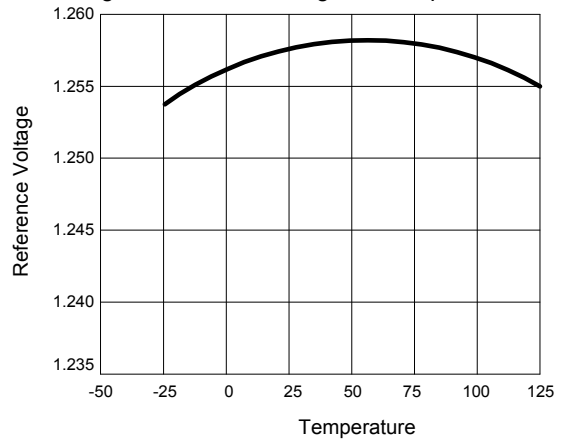
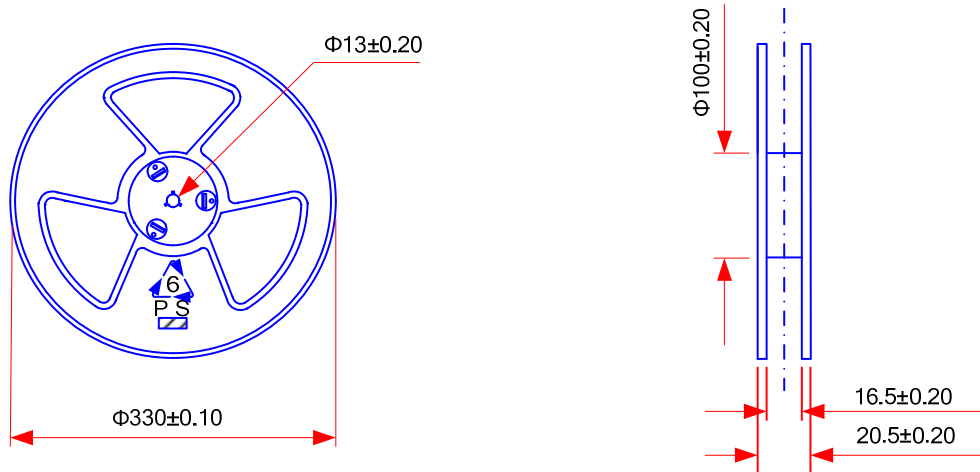

Fig.4 Reference Voltage vs Temperature



Taping reel dimension:



Taping dimension:

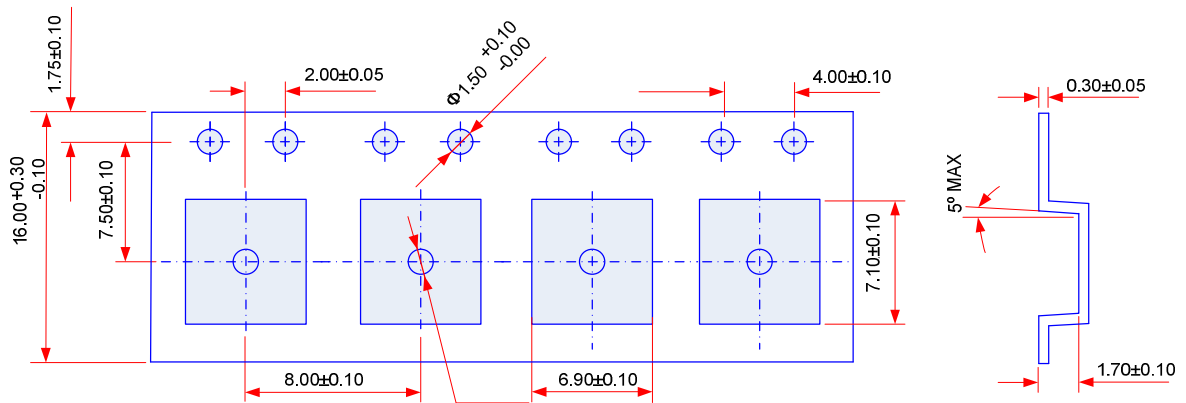

PACKAGE DIMENSIONS

TO-220
Unit: mm

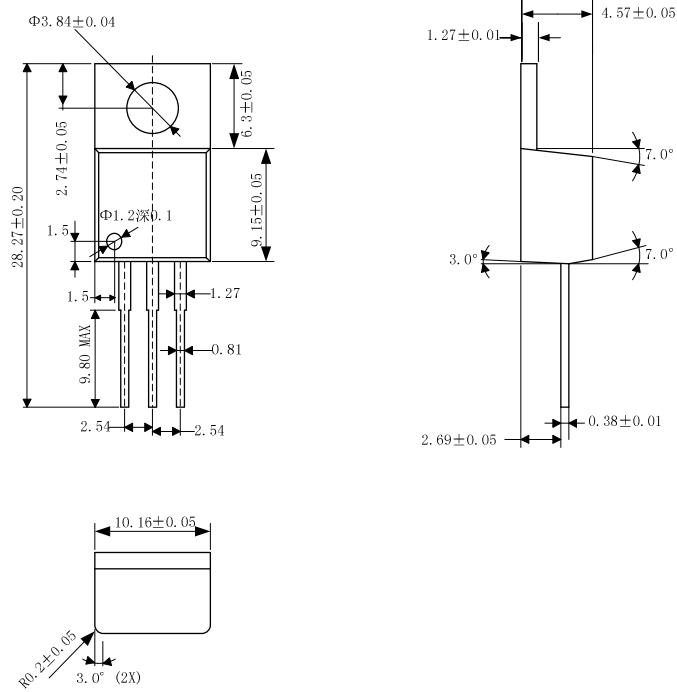

TO-252
Unit: mm

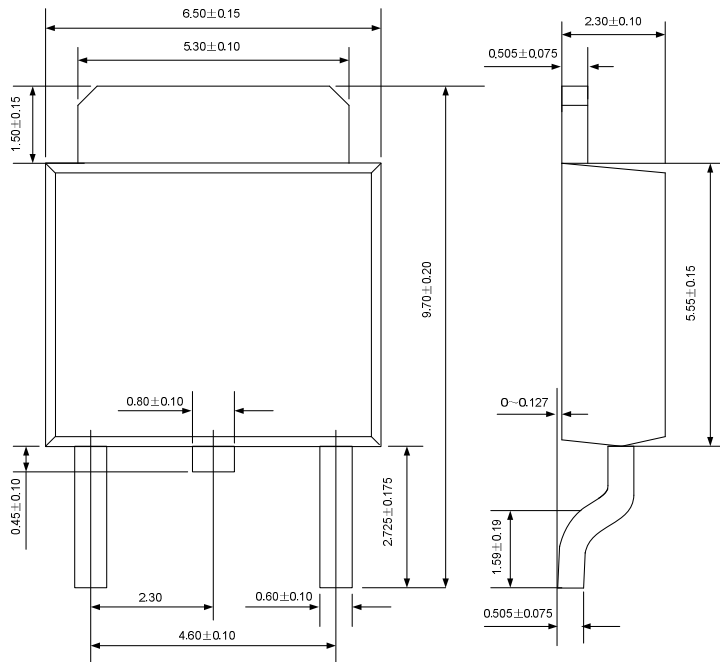

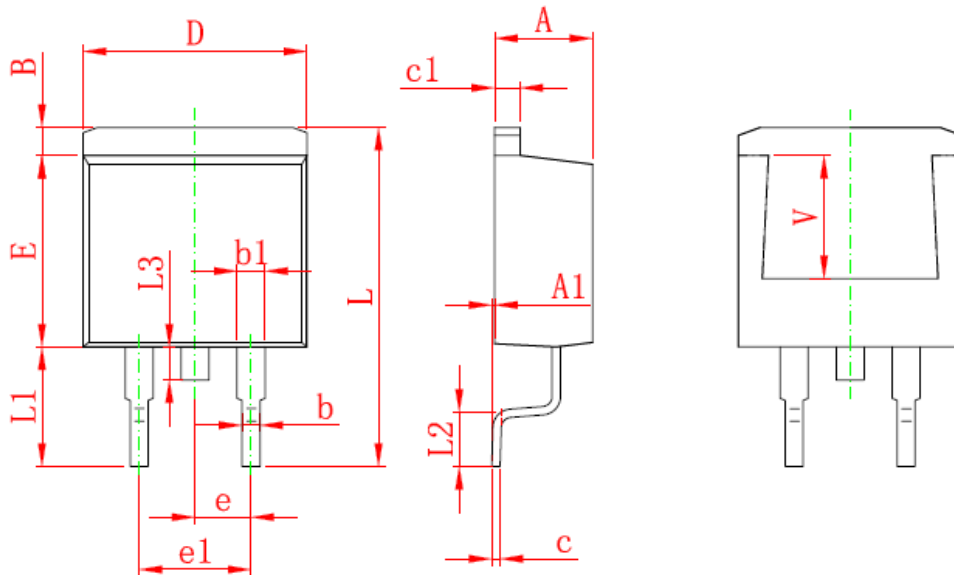
TO-263
 Unit: mm

Symbol	Dimensions In Millimeters		Dimensions In Inches	
	Min	Max	Min	Max
A	4.470	4.670	0.176	0.184
A1	0.000	0.150	0.000	0.006
B	1.170	1.370	0.046	0.054
b	0.710	0.910	0.028	0.036
b1	1.170	1.370	0.046	0.054
c	0.310	0.530	0.012	0.021
c1	1.170	1.370	0.046	0.054
D	10.010	10.310	0.394	0.406
E	8.500	8.900	0.335	0.350
e	2.540 TYP		0.100 TYP	
e1	4.980	5.180	0.196	0.204
L	15.050	15.450	0.593	0.608
L1	5.080	5.480	0.200	0.216
L2	2.340	2.740	0.092	0.108
L3	1.300	1.700	0.051	0.067
V	5.600 REF		0.220 REF	

TO-220F

Unit: mm

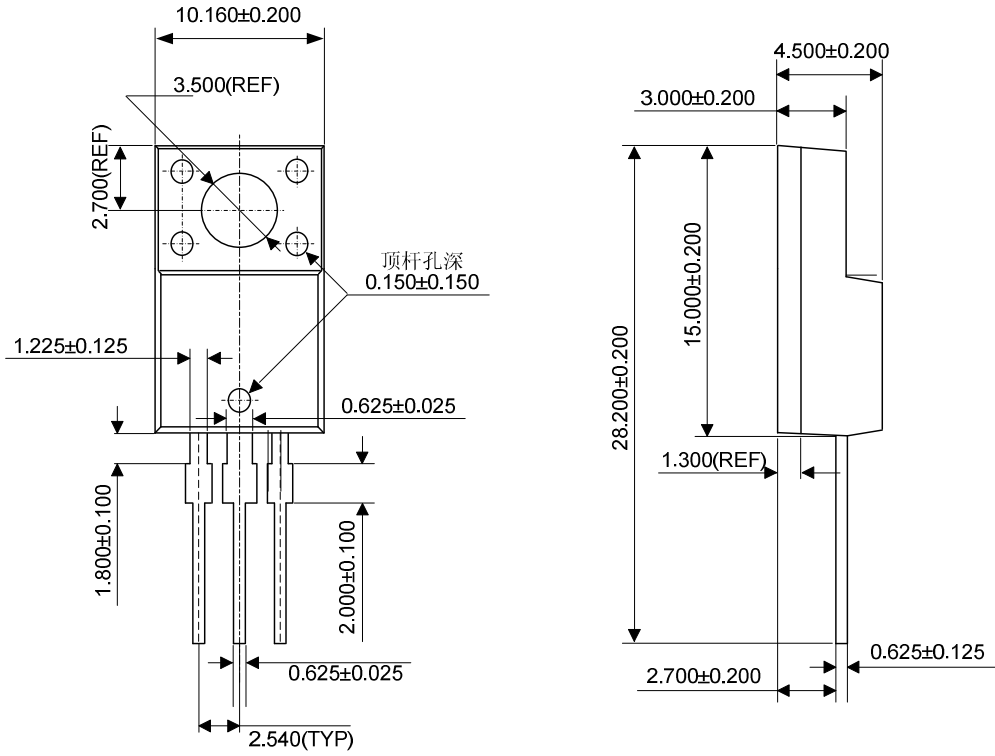

SOT-223

Unit: mm

