

# MMP60R190PE

## 600V 0.190Ω N-channel MOSFET

### ■ Description

MMP60R190PE is power MOSFET using Magnachip’s advanced super junction technology that can realize very low on-resistance and gate charge. It will provide much high efficiency by using optimized charge coupling technology. These user friendly devices give an advantage of Low EMI to designers as well as low switching loss.

### ■ Key Parameters

Parameter	Value	Unit
$V_{DS} @ T_{j, max}$	650	V
$R_{DS(on), max}$	0.19	Ω
$V_{TH, typ}$	3	V
$I_D$	20	A
$Q_g, typ$	51	nC

### ■ Package & Internal Circuit



### ■ Features

- Low Power Loss by High Speed Switching and Low On-Resistance
- 100% Avalanche Tested
- Green Package – Pb Free Plating, Halogen Free

### ■ Applications

- PFC Power Supply Stages
- Switching Applications
- Adapter

### ■ Ordering Information

Order Code	Marking	Temp. Range	Package	Packing	RoHS Status
MMP60R190PETH	60R190PE	-55 ~ 150°C	TO-220	Tube	Compliant

**■ Absolute Maximum Rating (Tc=25°C unless otherwise specified)**

Parameter	Symbol	Rating	Unit	Note
Drain – Source voltage	$V_{DSS}$	600	V	
Gate – Source voltage	$V_{GSS}$	±30	V	
Continuous drain current	$I_D$	20	A	$T_C=25^\circ\text{C}$
		12.7	A	$T_C=100^\circ\text{C}$
Pulsed drain current <sup>(1)</sup>	$I_{DM}$	60	A	
Power dissipation	$P_D$	154	W	
Single - pulse avalanche energy	$E_{AS}$	420	mJ	
MOSFET dv/dt ruggedness	dv/dt	50	V/ns	
Diode dv/dt ruggedness <sup>(2)</sup>	dv/dt	15	V/ns	
Storage temperature	$T_{stg}$	-55 ~150	°C	
Maximum operating junction temperature	$T_j$	150	°C	

1) Pulse width  $t_p$  limited by  $T_{j,max}$

2)  $I_{SD} \leq I_D, V_{DS\ peak} \leq V_{(BR)DSS}$

**■ Thermal Characteristics**

Parameter	Symbol	Value	Unit
Thermal resistance, junction-case max	$R_{thjc}$	0.81	°C/W
Thermal resistance, junction-ambient max	$R_{thja}$	62.5	°C/W

**■ Static Characteristics ( $T_c=25^\circ\text{C}$  unless otherwise specified)**

Parameter	Symbol	Min.	Typ.	Max.	Unit	Test Condition
Drain – Source Breakdown voltage	$V_{(BR)DSS}$	600	-	-	V	$V_{GS} = 0V, I_D = 0.25mA$
Gate Threshold Voltage	$V_{GS(th)}$	2	3	4	V	$V_{DS} = V_{GS}, I_D = 0.25mA$
Zero Gate Voltage Drain Current	$I_{DSS}$	-	-	1	$\mu A$	$V_{DS} = 600V, V_{GS} = 0V$
Gate Leakage Current	$I_{GSS}$	-	-	100	nA	$V_{GS} = \pm 30V, V_{DS} = 0V$
Drain-Source On State Resistance	$R_{DS(ON)}$	-	0.17	0.19	$\Omega$	$V_{GS} = 10V, I_D = 7.3A$

**■ Dynamic Characteristics ( $T_c=25^\circ\text{C}$  unless otherwise specified)**

Parameter	Symbol	Min.	Typ.	Max.	Unit	Test Condition
Input Capacitance	$C_{iss}$	-	1630	-	pF	$V_{DS} = 25V, V_{GS} = 0V, f = 1.0MHz$
Output Capacitance	$C_{oss}$	-	1250	-		
Reverse Transfer Capacitance	$C_{rss}$	-	74	-		
Effective Output Capacitance Energy Related <sup>(4)</sup>	$C_{o(er)}$	-	39	-		$V_{DS} = 0V$ to 480V, $V_{GS} = 0V, f = 1.0MHz$
Turn On Delay Time	$t_{d(on)}$	-	32	-	ns	$V_{GS} = 10V, R_G = 25\Omega, V_{DS} = 300V, I_D = 20A$
Rise Time	$t_r$	-	73	-		
Turn Off Delay Time	$t_{d(off)}$	-	146	-		
Fall Time	$t_f$	-	47	-		
Total Gate Charge	$Q_g$	-	51	-	nC	$V_{GS} = 10V, V_{DS} = 480V, I_D = 20A$
Gate – Source Charge	$Q_{gs}$	-	12	-		
Gate – Drain Charge	$Q_{gd}$	-	19	-		
Gate Resistance	$R_G$	-	3.0	-	$\Omega$	$V_{GS} = 0V, f = 1.0MHz$

3)  $C_{o(er)}$  is a capacitance that gives the same stored energy as  $C_{oss}$  while  $V_{DS}$  is rising from 0V to 80%  $V_{(BR)DSS}$

**■ Reverse Diode Characteristics ( $T_c=25^{\circ}\text{C}$  unless otherwise specified)**

Parameter	Symbol	Min.	Typ.	Max.	Unit	Test Condition
Continuous Diode Forward Current	$I_S$	-	-	20	A	
Diode Forward Voltage	$V_{SD}$	-	-	1.4	V	$I_S = 20\text{A}$ , $V_{GS} = 0\text{V}$
Reverse Recovery Time	$t_{rr}$	-	483	-	ns	$I_S = 20\text{A}$ $di/dt = 100\text{A/us}$ $V_{DD} = 100\text{V}$
Reverse Recovery Charge	$Q_{rr}$	-	7.6	-	$\mu\text{C}$	
Reverse Recovery Current	$I_{rrm}$	-	31.5	-	A	

■ Characteristic Graph

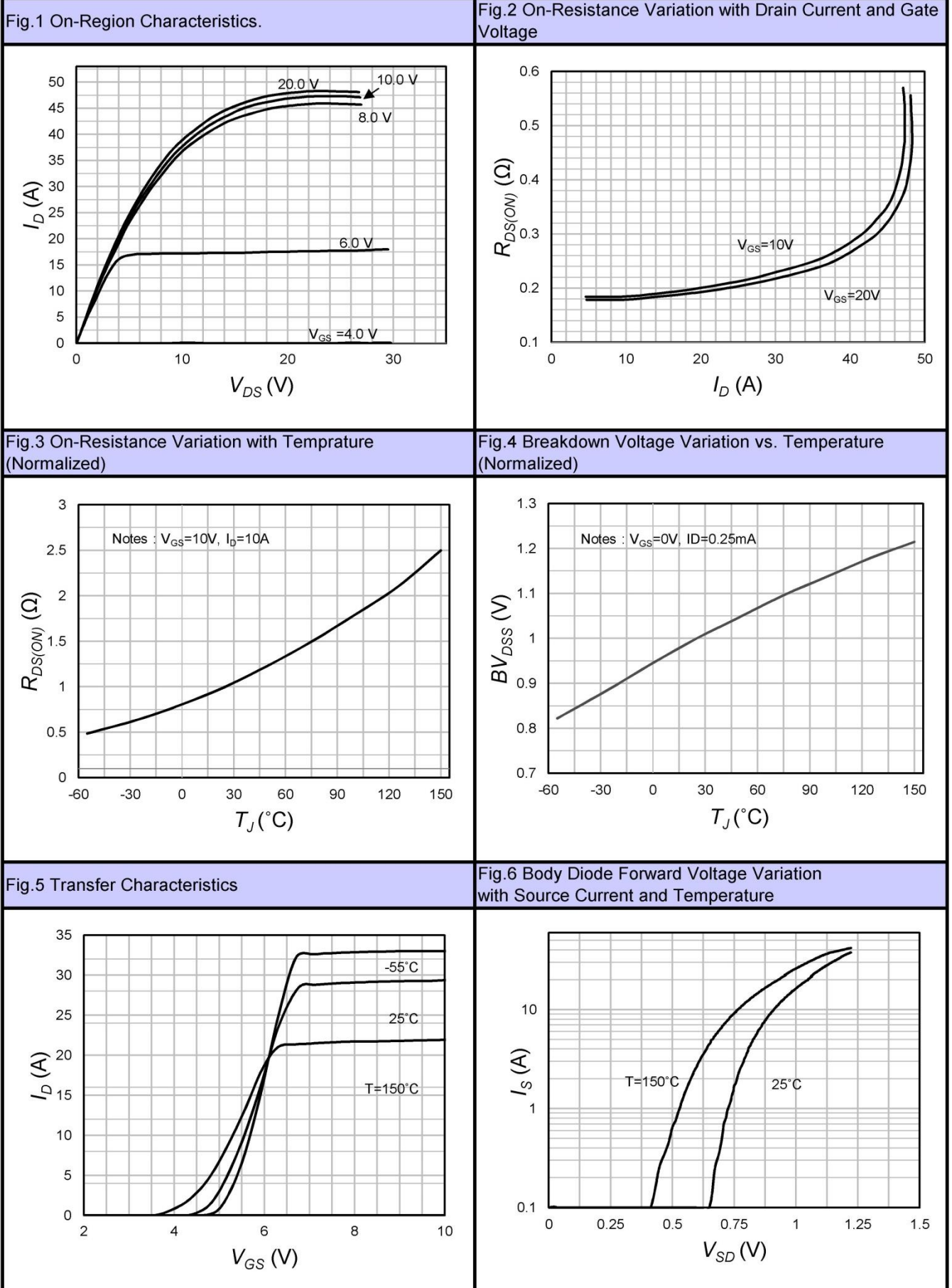

Fig.7 Gate Charge Characteristics

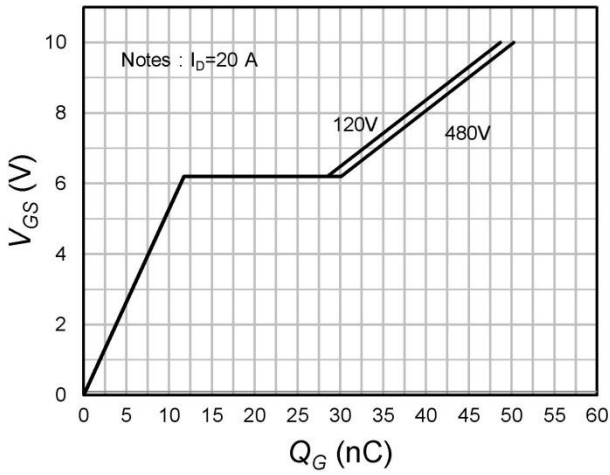

Fig.8 Capacitance Characteristics

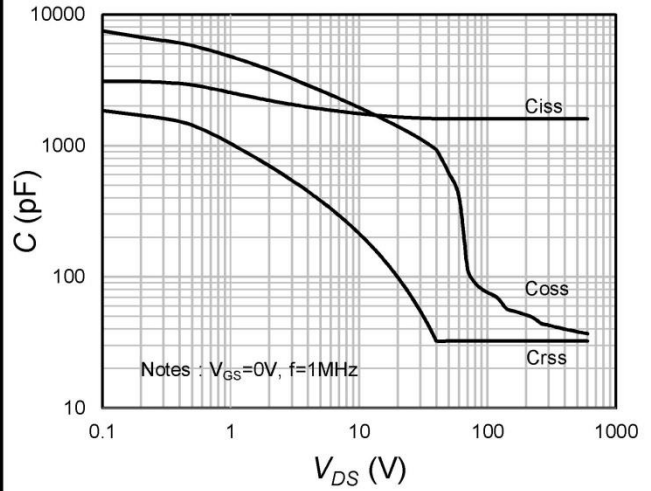

Fig.9  $V_{GS(th)}$  Variation with Temperature (Normalized)

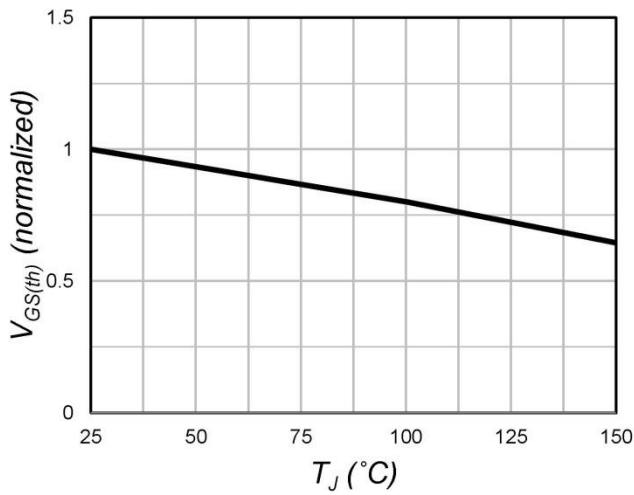

Fig.10 Maximum Drain Current vs. Case Temperature

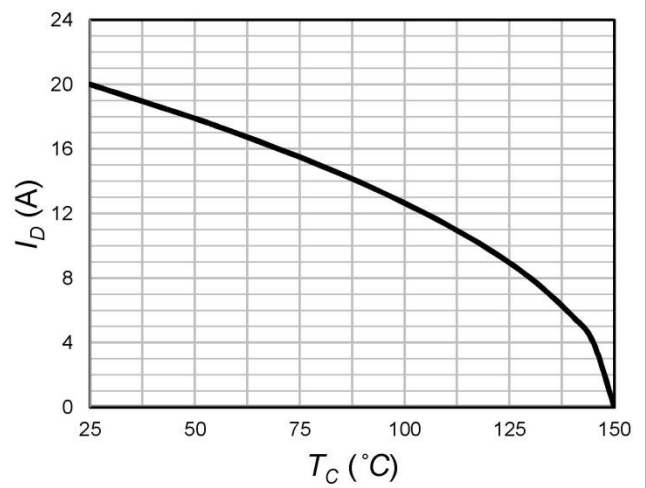

Fig.11 Single Pulse Maximum Power Dissipation

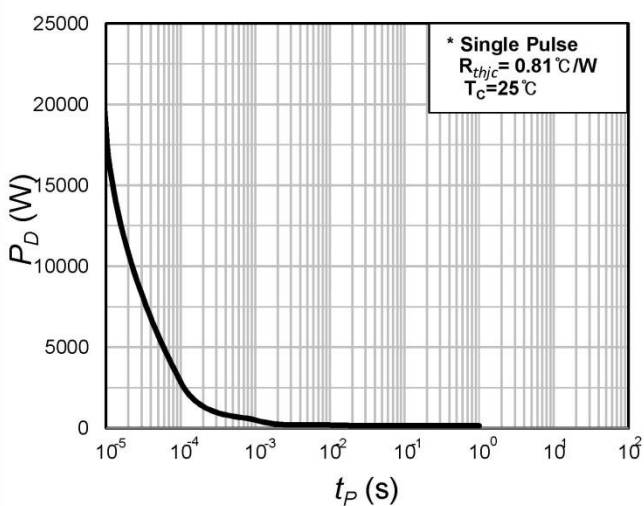

Fig.12 Output Capacitance Stored Energy

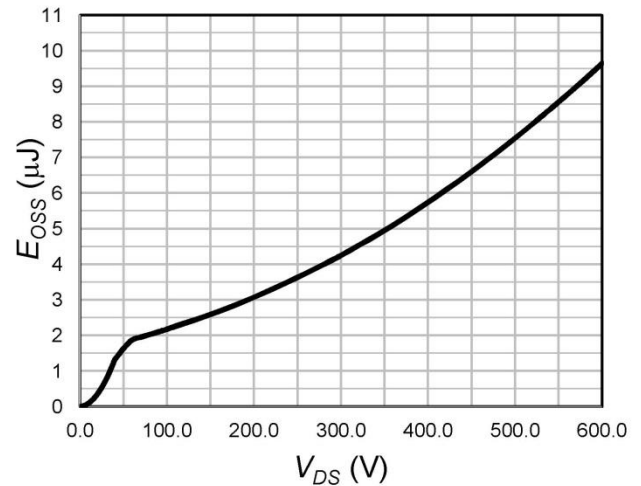

Fig.13 Transient Thermal Response Curve

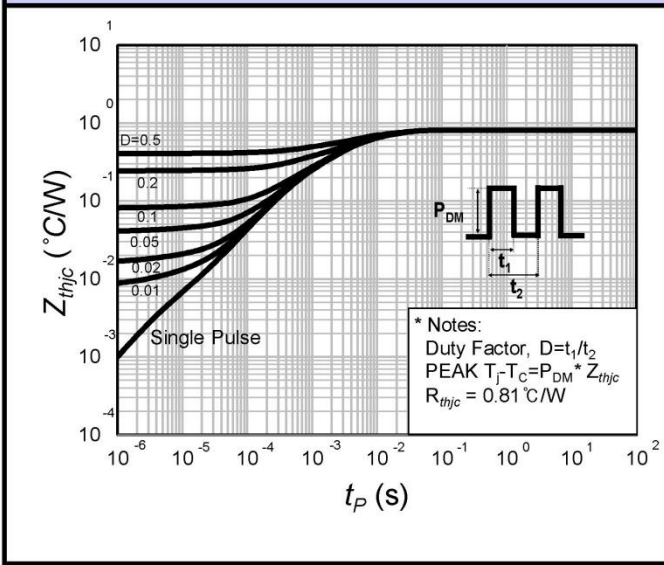
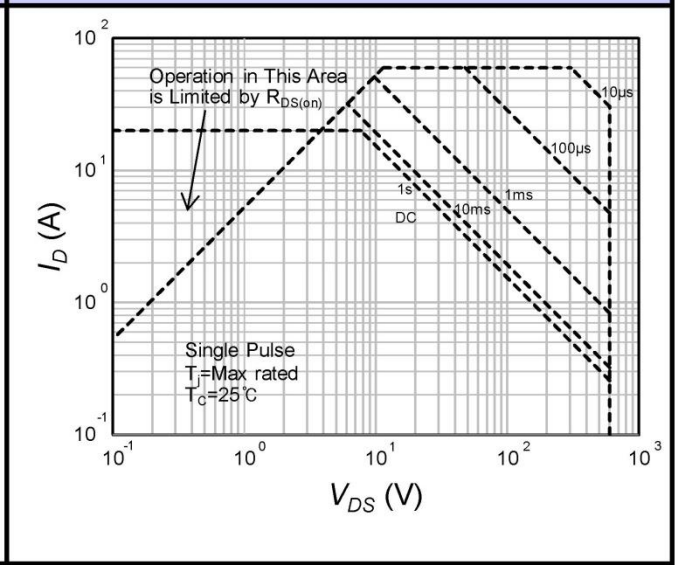

Fig.14 Maximum Safe Operating Area



■ Test Circuit

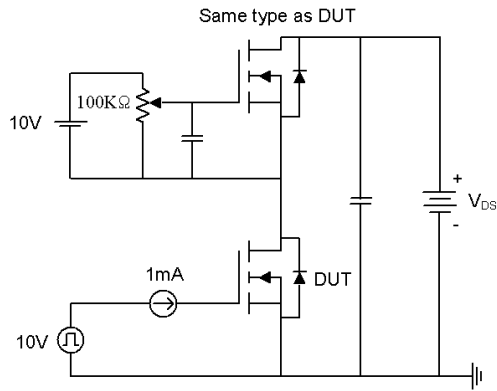

Fig15-1. Gate charge measurement circuit

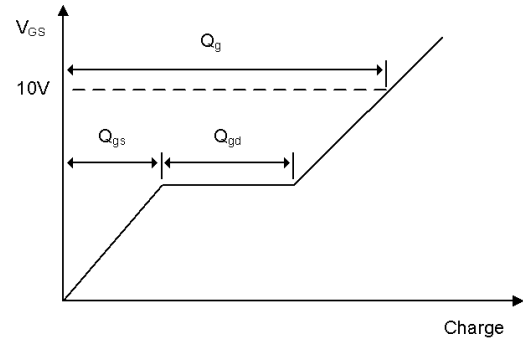

Fig15-2. Gate charge waveform

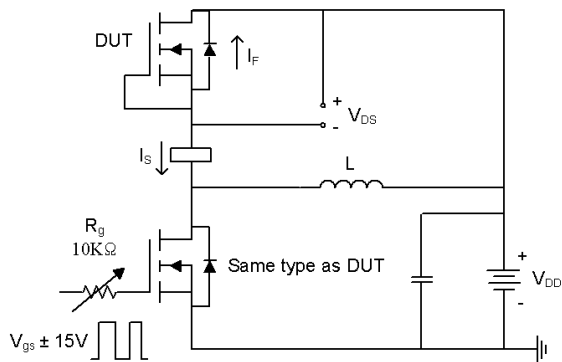

Fig16-1. Diode reverse recovery test circuit

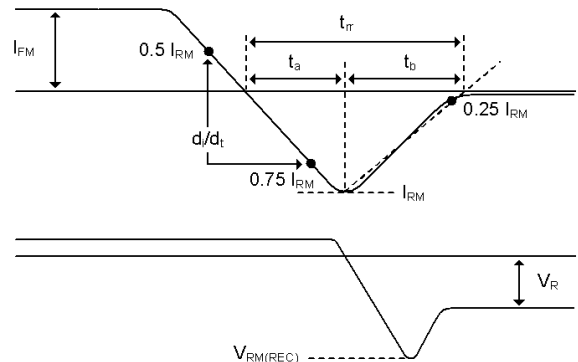

Fig16-2. Diode reverse recovery test waveform

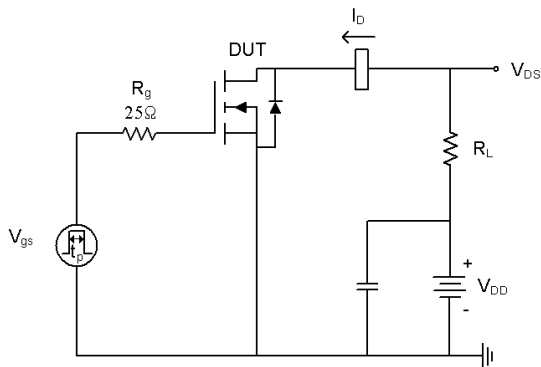

Fig17-1. Switching time test circuit for resistive load

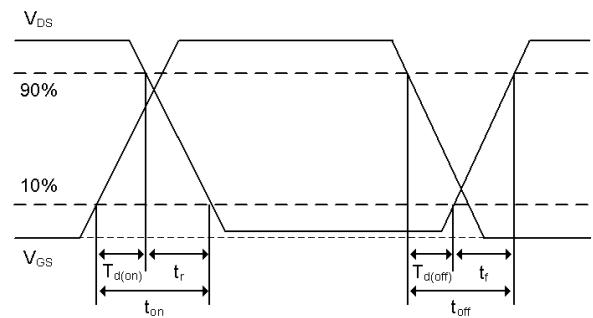

Fig17-2. Switching time waveform

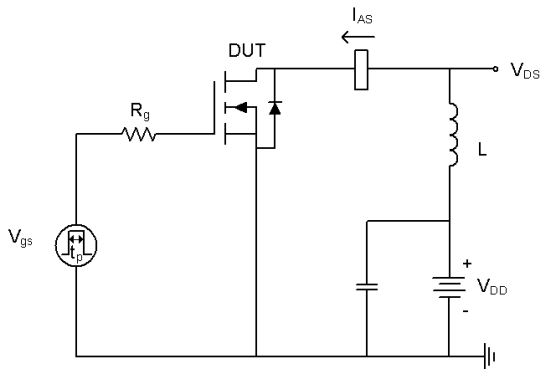

Fig18-1. Unclamped inductive load test circuit

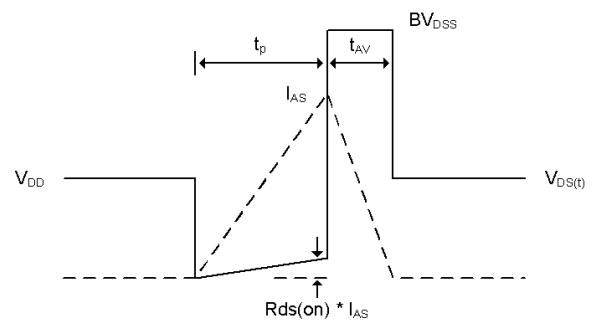
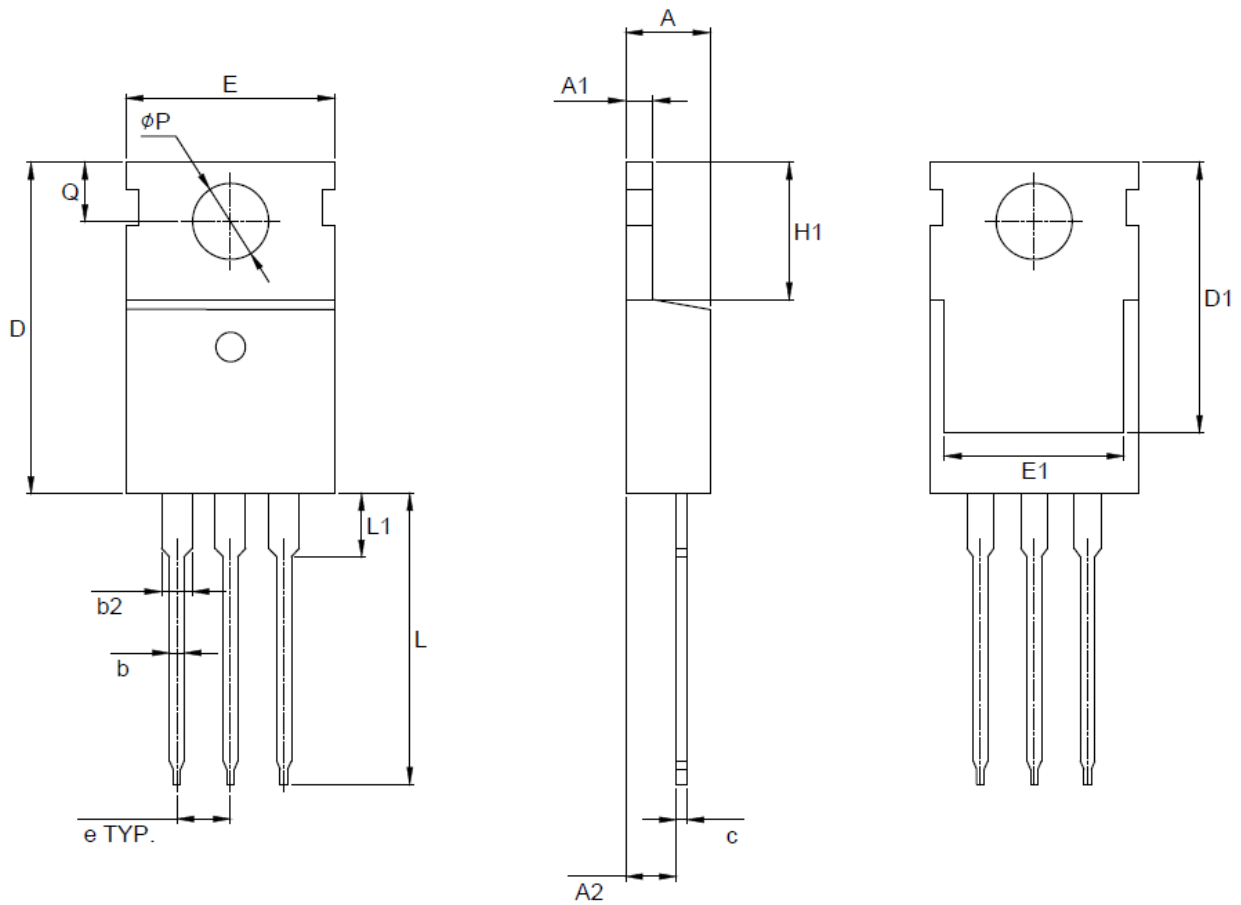

Fig18-2. Unclamped inductive waveform



**Physical Dimension**
**3 Leads, TO-220**

**Note : Package body size, length and width do not include mold flash, protrusions and gate burrs**

Symbol	Dimension (mm)		
	Min	Nom	Max
A	3.56	-	4.83
A1	0.50	-	1.40
A2	2.03	-	2.92
b	0.38	0.69	1.02
b2	1.14	1.45	1.78
c	0.36	-	0.61
D	14.22	-	16.51
D1	12.20	-	13.50
e	2.54 TYP		
E	9.65	-	10.67
E1	-	-	8.90
H1	5.84	-	6.86
L	12.70	-	14.73
L1	-	-	6.35
phi P	3.53	-	4.09
Q	2.54	-	3.43

**DISCLAIMER:**

The Products are not designed for use in hostile environments, including, without limitation, aircraft, nuclear power generation, medical appliances, and devices or systems in which malfunction of any Product can reasonably be expected to result in a personal injury. Seller's customers using or selling Seller's products for use in such applications do so at their own risk and agree to fully defend and indemnify Seller.

MagnaChip reserves the right to change the specifications and circuitry without notice at any time. MagnaChip does not consider responsibility for use of any circuitry other than circuitry entirely included in a MagnaChip product. [MagnaChip](#) is a registered trademark of MagnaChip Semiconductor Ltd.