

M5270L

LOW SATURATION OUTPUT TYPE CURRENT DRIVER

DESCRIPTION

M5270L is dual Darlington current driver (semiconductor integrated circuit) which consists of NPN transistors with clamp diode and it can be driven directly from 5V-type micro-computers or logic ICs.

Low saturation output can be obtained by separating the output stage transistor's collector from the drive stage transistors.

FEATURES

- High voltage resistance $BV_{CEO} \geq 80V$
- High input voltage resistance $V_1 \geq 20V$
- Large current drive $I_{C(max)} = 3.0A^*$
- Low saturation output $0.3V$ (typ) ($I_C = 0.7A$)
- Contains a clamp diode.
- Operates by the "H" level input.
- Wide operating temperature range . . . $T_a = -40 \sim +85^\circ C$
 * $PW = 10$ ms, duty cycle $\leq 10\%$

PIN CONFIGURATION (TOP VIEW)

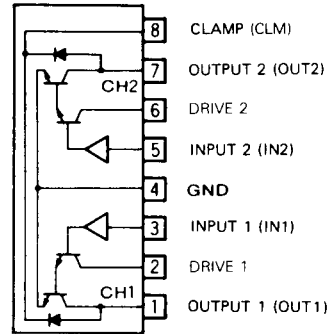

Outline 8P5

APPLICATION

Motor drives for various relays or portable printers, digit drives for display elements such as LEDs and lamps, or power amplifiers

FUNCTION

Unlike the existing common-collector-type transistor arrays, M5270L realizes 0.3V of low saturation output voltage (typ, $I_C = 0.7A$) by separating the drive stage collector from the output stage collector. Therefore, the power dissipation which is determined by the product of the load current and the saturation output voltage can be greatly decreased.

The maximum output current is 3.0A and up to 80V can be applied as the output voltage.

CIRCUIT DIAGRAM

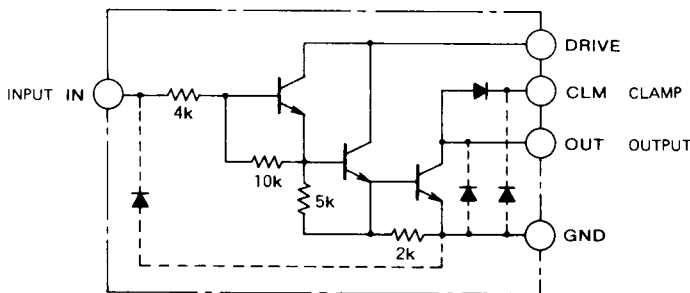

HIGH ACTIVE

* Output - Function

Input	Output
L	H(OFF)
H	L(ON)

CLM, GND are common to channels 1 and 2.
 The diode indicated by dashed lines are already contained in the IC structure, therefore, it is not necessary to attach it externally.

UNIT: Ω

LOW SATURATION OUTPUT TYPE CURRENT DRIVER**ABSOLUTE MAXIMUM RATINGS** ($T_a = 25^\circ\text{C}$, unless otherwise noted)

Symbol	Parameter	Conditions	Ratings	Unit
V_D	Drive stage applied voltage		80	V
V_{CE0}	Output voltage	When the output is "H"	80	V
V_I	Input voltage		20	V
I_C	Output current	Current per circuit when the output is "L"	3.0*	A
V_R	Clamp diode reverse voltage		80	V
I_F	Clamp diode forward current		3.0	A
P_d	Power dissipation	$T_a = 25^\circ\text{C}$	1, 2(1, 7)**	W
T_{opr}	Operating temperature		-40 ~ +85	$^\circ\text{C}$
T_{stg}	Storage temperature		-55 ~ +150	$^\circ\text{C}$

* : $PW = 10\text{ms}$, duty cycle $\leq 10\%$ ** : 400mm² of copper film is added**RECOMMENDED OPERATING CONDITIONS** ($T_a = 25^\circ\text{C}$, unless otherwise noted)

Symbol	Parameter	Conditions	Limits			Unit
			Min	Typ	Max	
V_D	Drive stage applied voltage		4	5	70	V
V_{CE}	Output applied voltage		0		70	V
I_C	Output current	Current per current	0	0.7	2.0	A
V_R	Clamp diode reverse voltage		0		70	V
I_F	Clamp diode forward current		0		2.0	A
P_d	Operating temperature		0		1.0	W

ELECTRICAL CHARACTERISTICS ($T_a = 25^\circ\text{C}$, value/circuit unless otherwise noted)

Symbol	Parameter	Test conditions	Limits			Unit
			Min	Typ	Max	
$V_{(BR)CE0}$	Output breakdown voltage	$I_{CE0} = 100\mu\text{A}$				V
$V_{CE(sat)}$	Saturation output voltage	$V_D = 4\text{V}$ $V_I = 3.5\text{V}$	$I_C = 1.8\text{A}, R_D = 30\Omega$	0.8	1.5	V
			$I_C = 1.0\text{A}, R_D = 50\Omega$	0.4	0.8	
			$I_C = 0.7\text{A}, R_D = 100\Omega$	0.3	0.6	
I_I	Input current	$V_I = 4\text{V}$			1.0	mA
		$V_I = 0.5\text{V}$			0.1	
$I_{O(leak)}$	Output lead current	$V_{CE} = 80\text{V}$			100	μA
I_R	Clamp diode leak current	$V_R = 80\text{V}$			50	μA
V_R	Clamp diode reverse voltage	$I_R = 100\mu\text{A}$	80			V
V_F	Clamp diode forward voltage	$I_F = 2.0\text{A}$			3.0	V
V_{IH}	"H" input voltage	$I_C = 2.0\text{A}$	3.5			V
V_{IL}	"L" input voltage	$I_{O(leak)} = 50\mu\text{A}$			1.0	V

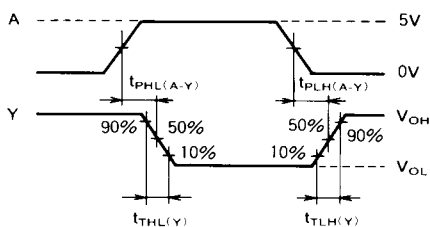
TIMING DIAGRAM**TYPICAL SPEED (Example)**

$t_{PHL(A-Y)}$	$t_{PLH(A-Y)}$	$t_{THL(Y)}$	$t_{TLH(Y)}$
400ns	3.2 μs	15ns	30ns

LOW SATURATION OUTPUT TYPE CURRENT DRIVER

TEST CIRCUITS

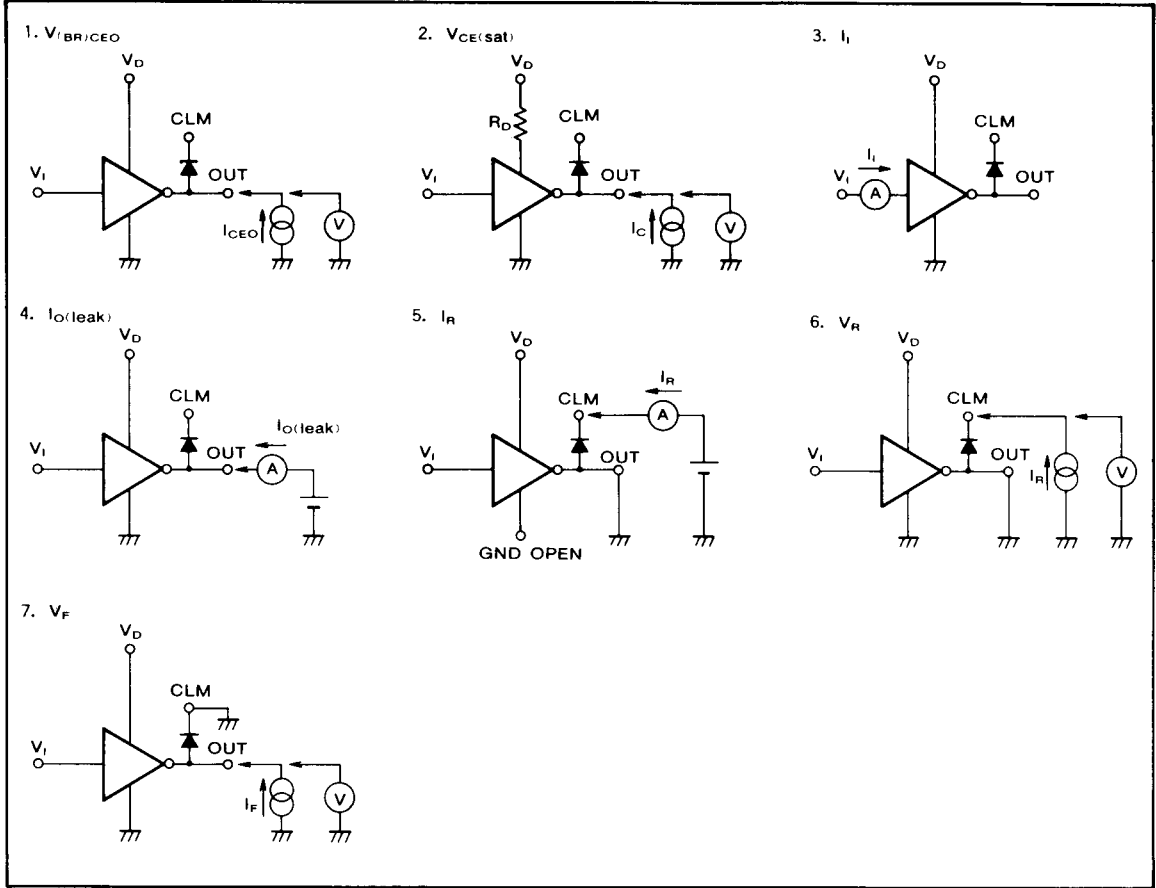

TYPICAL CHARACTERISTICS

THERMAL DERATING

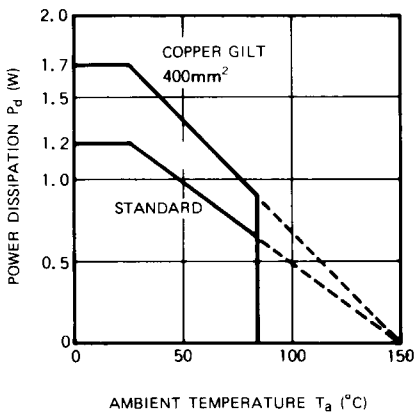

SAMPLE PCB LAYOUT

When you design a layout of a PCB, you have to consider the thermal derating. To improve the heat radiation of an IC, add a 400 mm² of copper film at the base of the GND pin. This will improve the thermal derating characteristics.

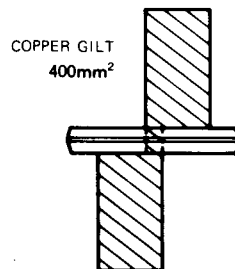

LOW SATURATION OUTPUT TYPE CURRENT DRIVER

SATURATION OUTPUT VOLTAGE VS. DRIVE STAGE RESISTANCE

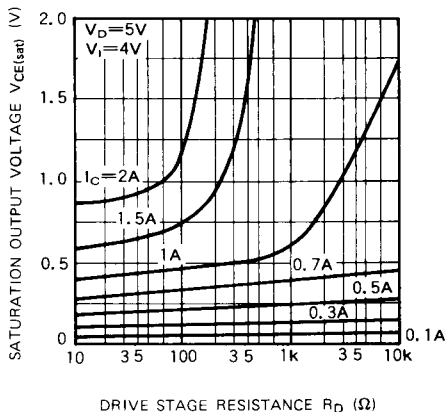

DRIVE STAGE VIAS VOLTAGE VS. DRIVE STAGE RESISTANCE

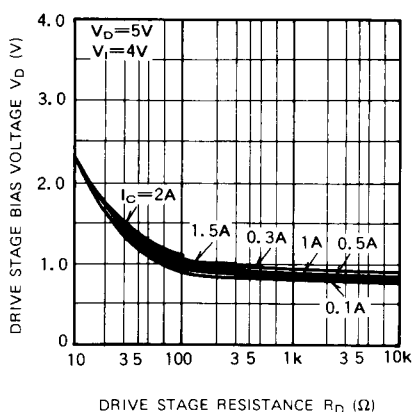

SATURATION OUTPUT VOLTAGE VS. OUTPUT CURRENT

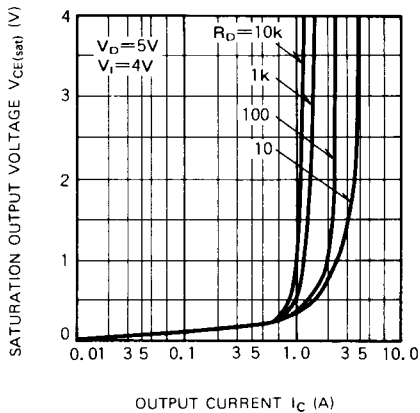

CLAMP DIODE FORWARD CURRENT VS. CLAMP DIODE FORWARD VOLTAGE

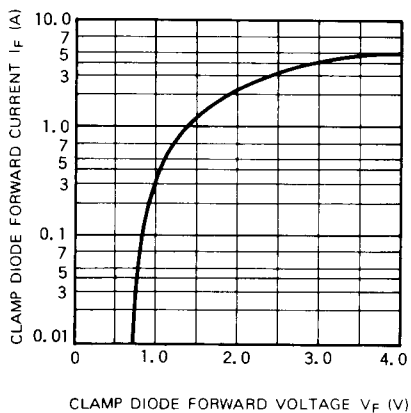

OUTPUT VOLTAGE VS. INPUT VOLTAGE

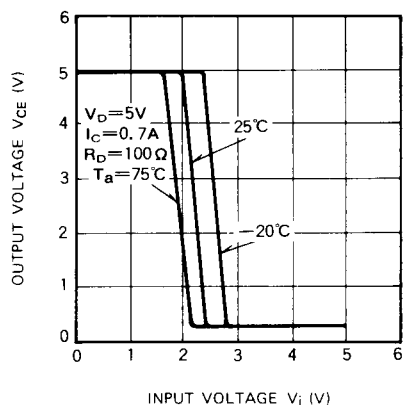

INPUT CURRENT VS. AMBIENT TEMPERATURE

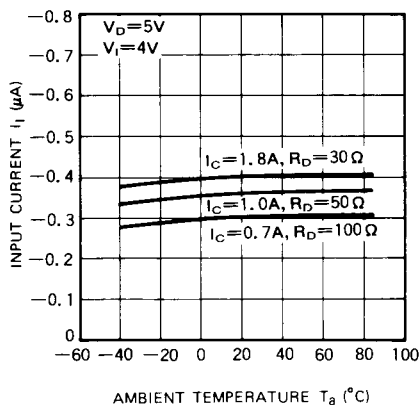

LOW SATURATION OUTPUT TYPE CURRENT DRIVER

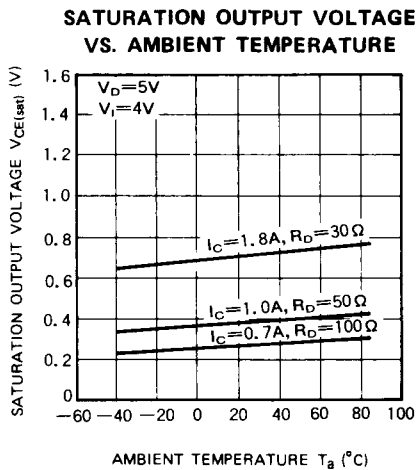

APPLICATION CIRCUIT (Stepping motor drive for a printer)

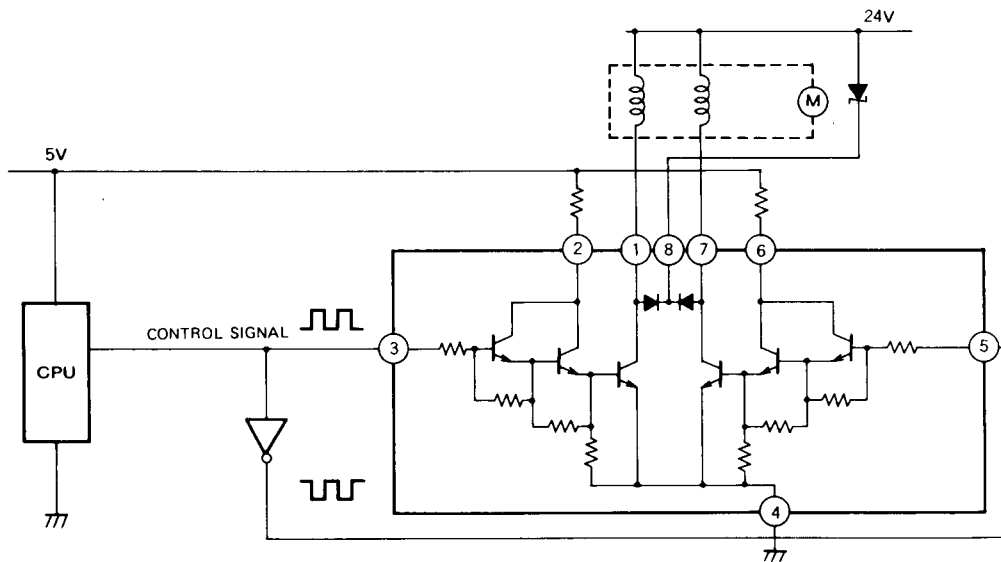

V_{CC} , DRIVE, CLAMP, AND GND ARE THE SAME FOR BOTH CIRCUITS.