



The Future of Analog IC Technology®

EVNB679

26V, Low Iq, High Current, Fixed 5.5V-8A Synchronous Buck Converter with 100mA LDO

PRELIMINARY SPECIFICATIONS SUBJECT TO CHANGE

DESCRIPTION

The NB679 is a fully integrated high frequency synchronous rectified step-down switch mode converter with fixed 5V Vout. It offers very compact solution to achieve 8A continuous output current and 10A peak output current over a wide input supply range with excellent load and line regulation.

The NB679 operates at high efficiency over a wide output current load rang based on MPS proprietary switching loss reduction tech and internal Low Ron Power MOSFETs

Adaptive Constant-On-Time (COT) control mode provides fast transient response and eases loop stabilization. The DC auto tune loop provides good load and line regulation.

NB679 also provide fixed 5V LDO which can be used to power the external peripherals.

Full protection features include OC Limit, OVP, UVP and thermal shut down. The converter requires minimum number of external components and is available in QFN 2x3 packages.

FEATURES

- Wide 5.5V to 26V Operating Input Range
- Fixed 5V Vout, Support 5.5V-5V
- Ultrasonic Mode
- 100µA low quiescent Current
- 8A Continous Output Current
- 10A Peak Output Current
- Adaptive COT for Fast transient
- DC Auto Tune Loop
- Stable with POSCAP and Ceramic Output
- Built-in 5V, 100mA LDO with Switch Over
- 1% Reference Voltage
- Internal Soft Start
- Output Discharge
- 700kHz Switching Frequency
- OCP, OVP, UVP(metal Hiccup) Protection and Thermal Shutdown.
- Latch off reset via EN or Power cycle.

APPLICATIONS

- Notebook Systems and Tablet PC
- Networking Systems and Server
- Personal Video Recorders
- Distributed Power Systems

All MPS parts are lead-free and adhere to the RoHS directive. For MPS green status, please visit MPS website under Products, Quality Assurance page. "MPS" and "The Future of Analog IC Technology" are registered trademarks of Monolithic Power Systems, Inc.

EVNB679-D-00A EVALUATION BOARD



(L x W) 635mm x 635mm

Board Number	MPS IC Number
EVNB679-D-00A	NB679

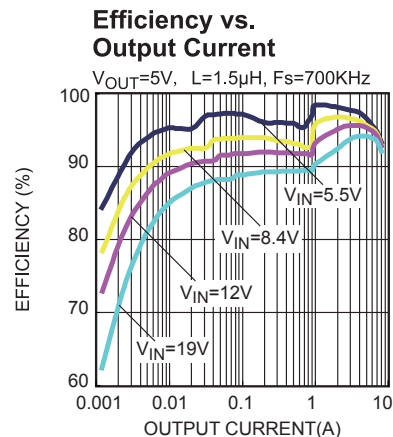

EVALUATION BOARD SCHEMATIC

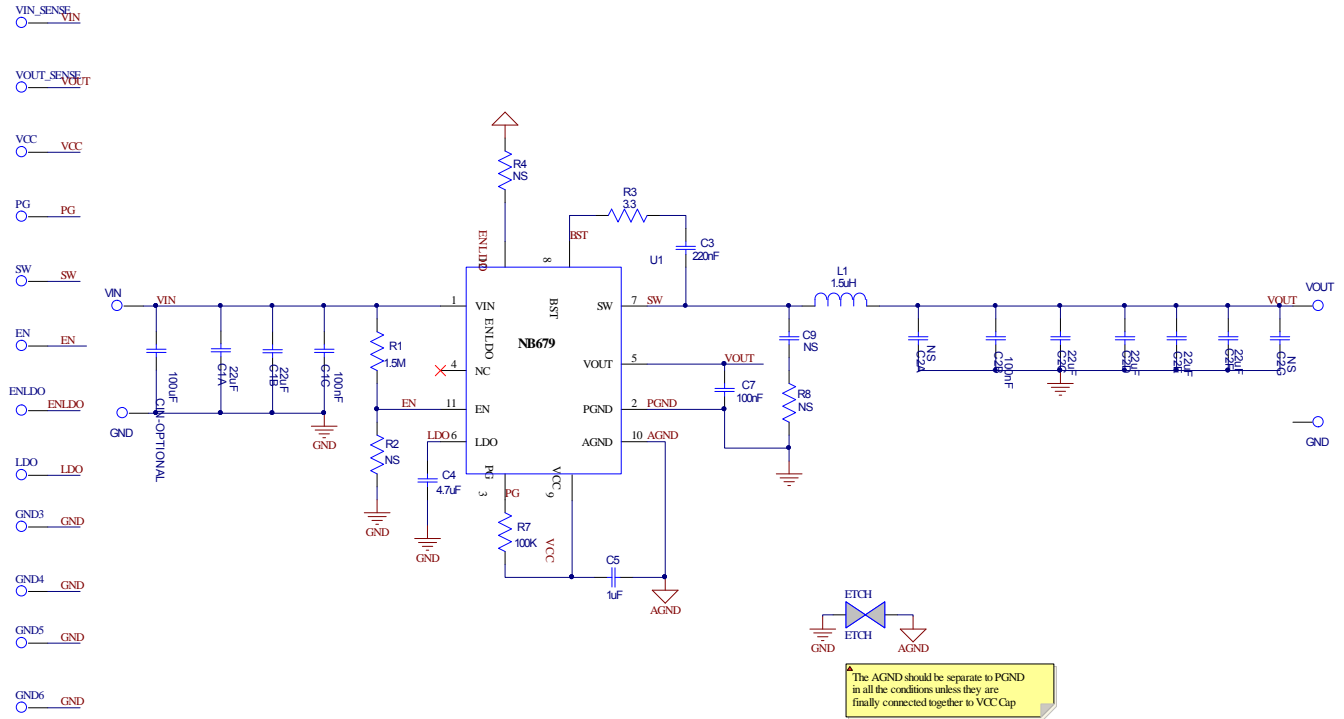

EVNB679 BILL OF MATERIALS

Qty	Ref	Value	Description	Package	Manufacture	Manufacture_PN
2	C1A, C1B	22 μ F	Ceramic Capacitor;25V;X5R	1206	Murata	GRM21BR61E226KE15
2	C1C, C2B	100nF	Ceramic Capacitor;50V;X7R	0603	Murata	GRM188R71H104KA93D
6	C2A, C2G, C9, R2, R4, R8	NS				
4	C2C, C2D, C2E, C2F	22 μ F	Ceramic Capacitor;6.3V;X5R	0805	Murata	GRM21BR60J226ME39L
1	C3	220nF	Capacitor;16V;X5R	0402	Murata	GRM155R71C224KA12D
1	C4	4.7 μ F	Capacitor;6.3V;X5R	0402	TDK	C1005X5R0J475M
1	C5	1 μ F	Ceramic Capacitor;25V;X7R	0402	Murata	GRM155R61E105KA12
1	C7	100nF	Ceramic Capacitor;50V;X7R	0402	TDK	C1005X7R1C104K
1	CIN-OPTIONAL	100 μ F	Capacitor;25V	SMD		
12	EN, ENLDO, GND, GND, GND, GND, LDO, PG, SW, VCC, VIN_SENSE, VOUT_SENSE	Connector	Connector,1mm			
4	GND, GND, VIN, VOUT	Connector	Connector,2mm			
1	L1	1.5 μ H	Inductor;1.5uH;10m;14A	SMD	Würth	744311150
1	R1	1.5M	Resistor;1%;	0402	Yageo	RC0402FR-071M5L
1	R3	3.3	Film Resistor;5%	0603	Yageo	RC0603JR-073R3L
1	R7	100k	Film Resistor;5%	0402	CYNTEC	RR0510S-1003-JN
1	U1	NB679	NB679	QFN2*3	MPS	NB679

PRINTED CIRCUIT BOARD LAYOUT

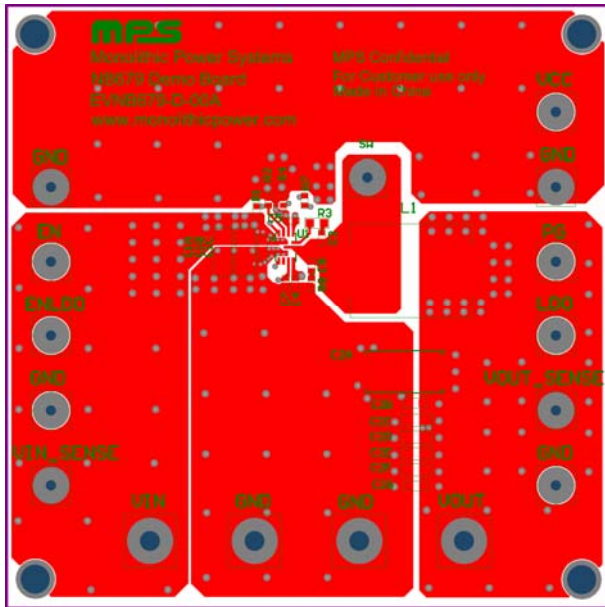

Figure 1—Top Layer and Silk

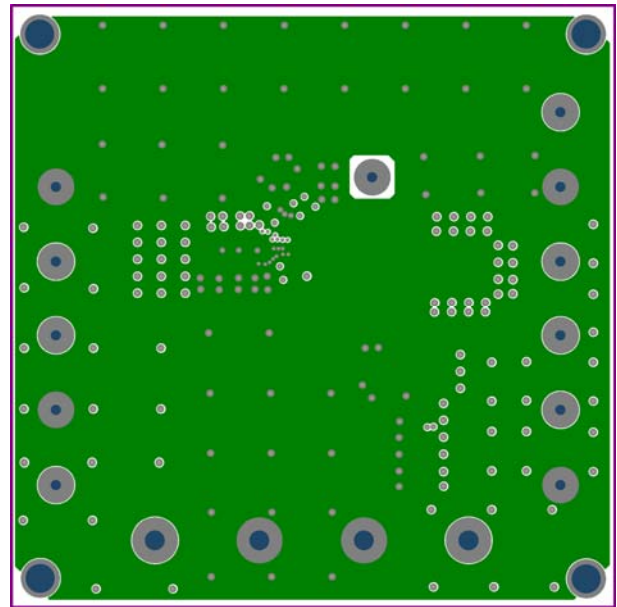

Figure 2—Inner Layer 1

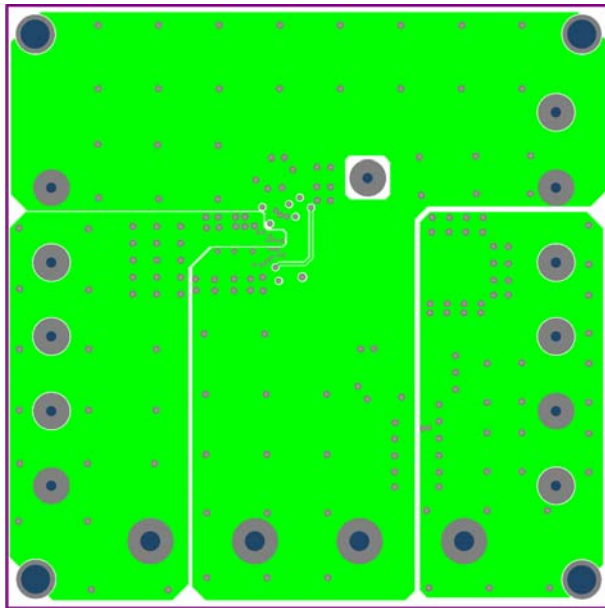

Figure 3—Inner Layer 2

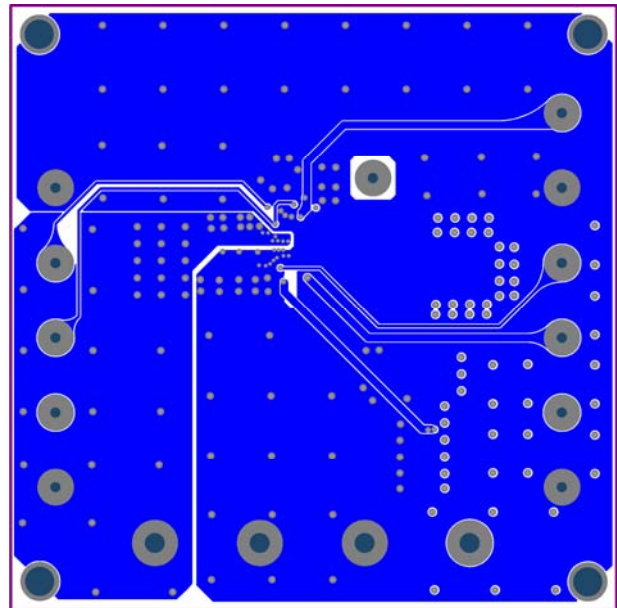

Figure 4—Bottom Layer

QUICK START GUIDE

1. Connect the positive and negative terminals of the load to the VOUT and GND pins, respectively.
2. Preset the one power supply output between 5.5V and 24V as VIN, and then turn off the power supply.
3. Connect the positive and negative terminals of the power supply output to the VIN and GND pins, respectively.
4. Turn the VIN power supply on. The NB679 will automatically startup.
5. To use the Enable function, apply a digital input to the EN pin. Drive EN higher than 2V to turn on the regulator or less than 0.4V to turn it off.

NOTICE: The information in this document is subject to change without notice. Users should warrant and guarantee that third party Intellectual Property rights are not infringed upon when integrating MPS products into any application. MPS will not assume any legal responsibility for any said applications.