

General Description

EC3201S is a high efficiency step down DC/DC converter operated with current mode and constant frequency. The internal switch and synchronous rectifier are integrated for high efficiency. External Schottky diodes are not required. The supply current is only 110 μ A during operation and drops to less than 1 μ A in shutdown. EC3201S can supply 1A of load current from 2.5V to 5.5V supply voltage.

The switching frequency is set at 1.5MHz, allowing the use of small surface mount inductors and capacitors. It can run 100% duty cycle for low dropout application. The output voltage of EC3201S is adjustable from the FB pin. EC3201S is RoHS compliant and Lead (Pb) Free.

Features

- 1A output current
- Current mode operation
- High efficiency up to 95%
- Shutdown current < 1 μ A
- 2.5V to 5.5V supply voltage
- Over temperature protection
- Constant frequency operation
- Full duty ratio, 0 – 100% in dropout
- RoHS Compliant and Lead (Pb) Free

Applications

- Cellular phones
- PDAs and smart phones
- MP3 players
- Digital still cameras
- Slim-type DVD
- Wireless and DSL card
- Microprocessors and DSP core supplies
- Portable instruments

Pin Assignments

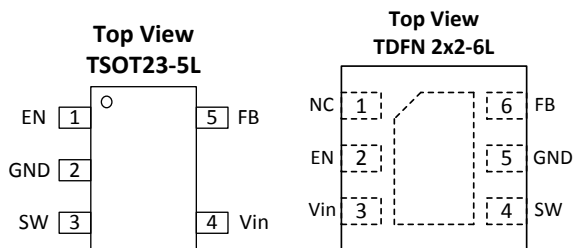

Pin Description

TSOT23-5L	TDFN 2x2-6L	Symbol	Description
1	2	EN	Enable control input pin.
2	5	GND	Ground pin.
3	4	SW	Power switch output.
4	3	Vin	Main supply pin.
---	1	NC	No connected.
5	6	FB	Feedback pin. $V_{out}=0.6 \times (1+R1/R2)$. Add optional C1 to speed up transient response.

Typical Application Circuit, Adjustable Output Voltage

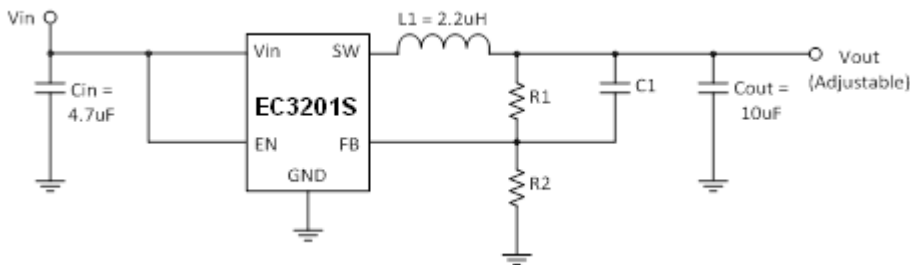

$$V_{out} = V_{FB} \times (1 + R1/R2)$$

with $R1 = 300k$ for typical application,

and $C1$ should be in the range between $10pF$ and $47pF$ for component selection.

Ordering Information

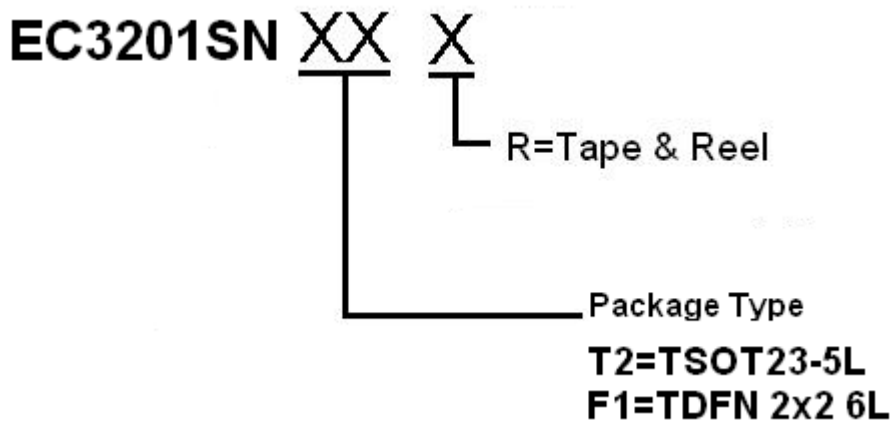

Part Number	Package	Marking	Marking Information
EC3201SNT2R	TSOT23-5L	06LDD	1. L : Lot No 2. DD : Date Code

Absolute Maximum Ratings

(Note 1)

Vin to GND	-0.3V to +6V
SW Voltage to GND	-0.3V to Vin+0.3V
EN Voltage to GND	-0.3V to Vin
FB/Vout to GND	-0.3V to Vin
SW Peak Current	3A
Operating Temperature Range	-40°C to +85°C
Junction Temperature	+150°C
Storage Temperature Range	-65°C to +150°C
Lead Temperature (Soldering 10s)	+260°C
ESD Classification	Class 2

CAUTION: Stresses above those listed in “Absolute Maximum Ratings” may cause permanent damage to the device. This is a stress only rating and operation of the device at these or any other conditions above those indicated in the operational sections of this specification is not implied.

Package Thermal Characteristics

(Note 2)

TSOT23-5L:	
Thermal Resistance, θ_{JA}	250°C/W
Thermal Resistance, θ_{JC}	130°C/W
TDFN 2x2-6L:	
Thermal Resistance, θ_{JA}	120°C/W
Thermal Resistance, θ_{JC}	20°C/W

Recommended Operating Conditions

(Note 3)

Supply Input Voltage	+2.5V to +5.5V
Junction Temperature Range	-40°C to +125°C
Ambient Temperature Range	-40°C to +85°C

Block Diagram

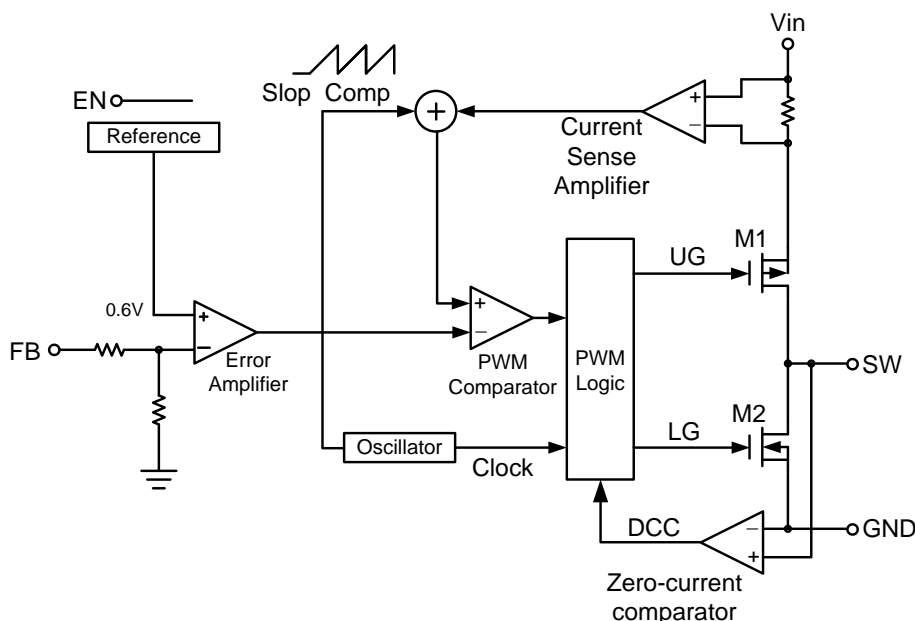



Electrical Characteristics

($V_{in} = 5V$, $V_{out} = 1.8V$, $L = 2.2\mu H$, $C_{out} = 10\mu F$, $T_A = 25^\circ C$, unless otherwise specified)

PARAMETER	Symbol	TEST CONDITIONS	MIN	TYP	MAX	UNIT
Supply Voltage	V_{in}		2.5		5.5	V
Output Voltage Line Regulation	ΔV_{out}	$V_{in} = 2.5V$ to $5.5V$	-3		3	%V
Output Voltage Load Regulation	V_{LR}		-3		3	%
Reference Voltage	V_{REF}	For adjustable V_{out}	0.588	0.6	0.612	V
Output Range (Adjustable Voltage)	V_{out}	$V_{in} = 2.5V$ to $5.5V$	-3		+3	%
Shutdown Current	I_S	$V_{EN} = 0V$		0.1	1	μA
Quiescent Current	I_Q	$V_{EN} = V_{in}$, $V_{FB} = V_{REF} \times 1.1$ No Switching		110		μA
SW Leakage Current	I_{LEAK}	$V_{EN} = 0V$, $V_{SW} = 0V$ or V_{in}	-1		1	μA
PMOSFET On Resistance*	$R_{DS(ON)P}$	$I_{SW} = 100mA$		250		$m\Omega$
NMOSFET On Resistance*	$R_{DS(ON)N}$	$I_{SW} = -100mA$		200		$m\Omega$
PMOSFET Current Limit*	I_{LIM}	Duty cycle = 100% Current Pulse Width < 1ms		2		A
Oscillator Frequency	F_{OSC}		1.2	1.5	1.8	MHz
Thermal Shutdown Threshold*	T_S			160		$^\circ C$
EN High Level Input Voltage	V_{ENH}	$-40^\circ C \leq T_A \leq 85^\circ C$	1.5			V
EN Low Level Input Voltage	V_{ENL}	$-40^\circ C \leq T_A \leq 85^\circ C$			0.4	V
EN Input Current	I_{EN}	$V_{EN} = 0V$ to V_{in}	-1		1	μA

* Guaranteed by design not for test.

Note 1: Stresses beyond those listed "Absolute Maximum Ratings" may cause permanent damage to the device. These are stress ratings only, and functional operation of the device at these or any other conditions beyond those indicated in the operational sections of the specifications is not implied. Exposure to absolute maximum rating conditions may affect device reliability.

Note 2: θ_{JA} is measured in the natural convection at $T_A = 25^\circ C$ on a low effective single layer thermal conductivity test board of JEDEC 51-3 thermal measurement standard. Pin 2 of TSOT23-5 packages is the case position for θ_{JC} measurement. Measured at the exposed pad of the package.

Note 3: The device is not guaranteed to function outside its operating conditions.

Typical Characteristics

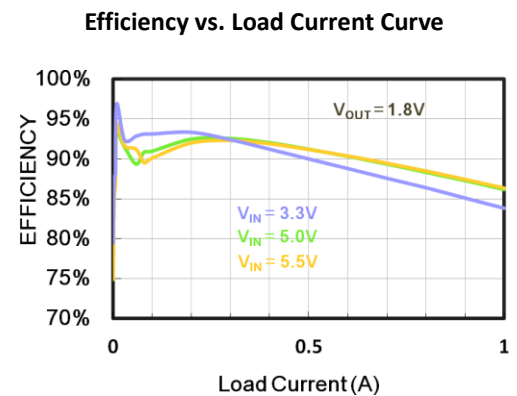
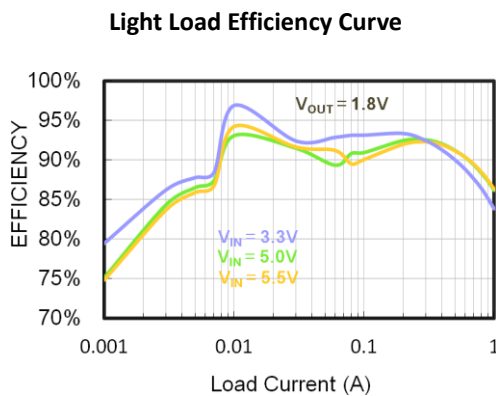
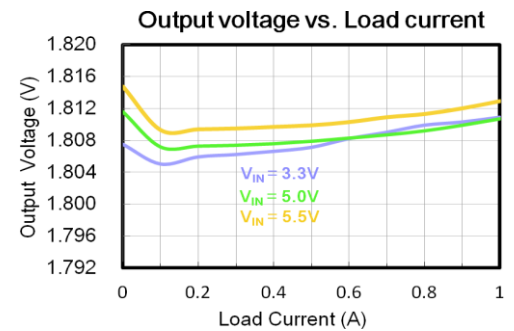
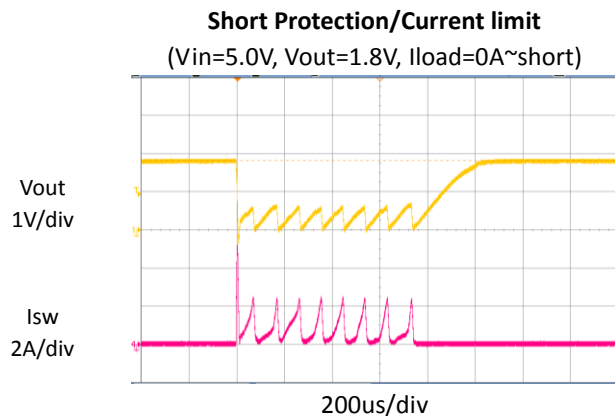
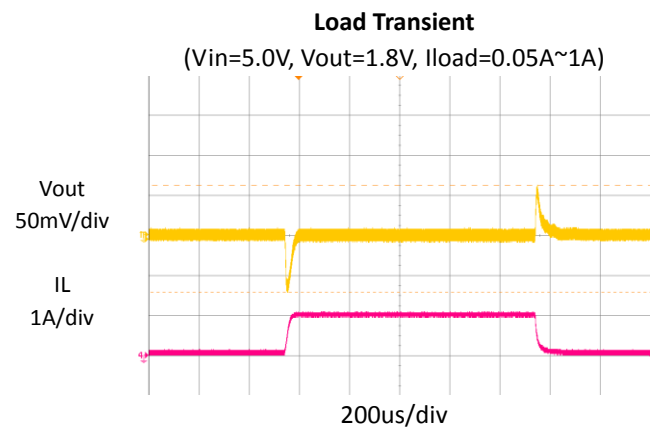
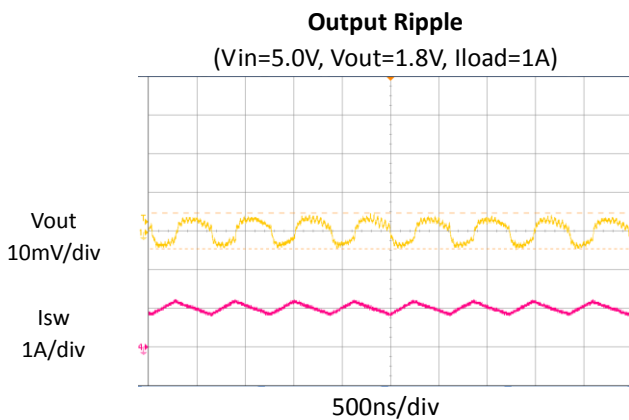
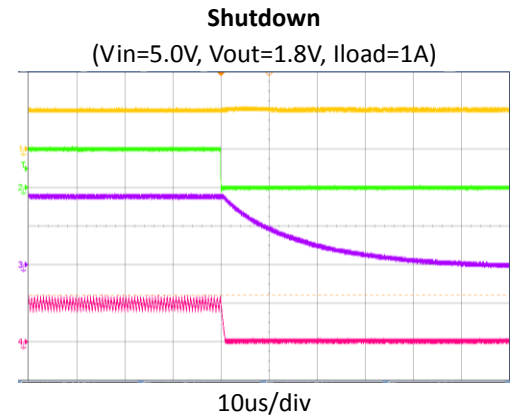
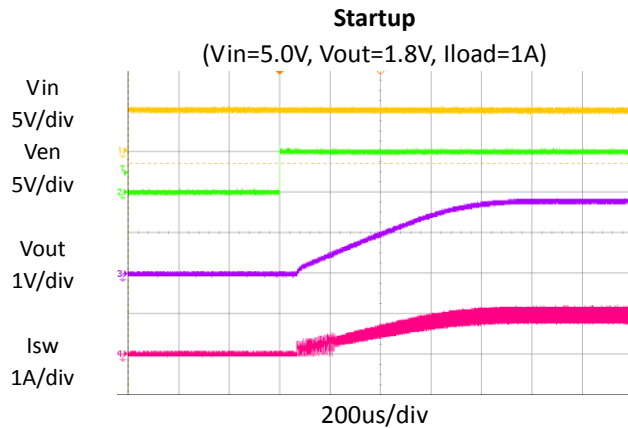



FUNCTIONAL DESCRIPTION

Overview

The EC3201S is a constant frequency current mode PWM step down converter. EC3201S is optimized for low voltage, Li-ion battery, powered applications where high efficiency and small size are critical. The device integrates both a main switch and a synchronous rectifier, which provides high efficiency and eliminates an external Schottky diode. EC3201S can achieve 100% duty cycle. The duty cycle D of a step down converter is defined as:

$$D = T_{ON} \times F_{OSC} \times 100\% \approx \frac{V_{out}}{V_{in}} \times 100\%$$

Where T_{ON} is the main switch on time, F_{OSC} is the oscillator frequency (1.5MHz), V_{out} is the output voltage and V_{in} is the input voltage.

Current Mode PWM Control

Slope compensated current mode PWM control provides stable switching and cycle-by-cycle current limit for superior load and line response and protection of the internal main switch and synchronous rectifier. EC3201S switches at a constant frequency (1.5MHz) and regulates the output voltage. During each cycle the PWM comparator modulates the power transferred to the load by changing the inductor peak current based on the feedback error voltage. During normal operation, the main switch is turned on for a certain time to ramp the inductor current at each rising edge of the internal oscillator, and switched off when the peak inductor current is above the error voltage. When the main switch is off, the synchronous rectifier will be turned on immediately and stay on until either the next cycle starts or the inductor current drops to zero. The device skips pulses to improve efficiency at light load.

Dropout Operation

EC3201S allows the main switch to remain on for more than one switching cycle and increases the duty cycle while the input voltage is dropping close to the output voltage. When the duty cycle reaches 100%, the main switch is held on continuously to deliver current to the output up to the P MOSFET current limit. The output voltage then is the input voltage minus the voltage drop across the main switch and the inductor.

Short Circuit Protection

The EC3201S has short circuit protection. When the output is shorted to ground, the oscillator frequency is reduced to prevent the inductor current from increasing beyond the P MOSFET current limit. The frequency will return to the normal values once the short circuit condition is removed and the V_{out} reaches regulated voltage.

Maximum Load Current

The EC3201S can operate down to 2.5V input voltage; however the maximum load current decreases at lower input due to large IR drop on the main switch and synchronous rectifier. The slope compensation signal reduces the peak inductor current as a function of the duty cycle to prevent sub-harmonic oscillations at duty cycles greater than 50%. Conversely the current limit increases as the duty cycle decreases.



APPLICATION INFORMATION

Inductor Selection

A 2.2μH to 4.7μH is recommended for general use. The value of inductor depends on the operating frequency. Higher frequency allows smaller inductor and capacitor but increases internal switching loss. Two inductor parameters should be considered, current rating and DCR. The inductor with the lowest DCR is chosen for the highest efficiency.

The inductor value can be calculated as:

$$L \geq [V_{OUT}/(f \times \Delta I_L)](1 - V_{OUT}/V_{IN})$$

ΔI_L : inductor ripple current, which is defined as:

$$\begin{aligned} \Delta I_L &= V_{OUT}[(1 - V_{OUT}/V_{IN})/(L \times f)] \quad (\text{General Setting}) \\ &\approx \alpha \times I_{O-MAX} \quad (\alpha = 0.2 \sim 0.4) \end{aligned}$$

The inductor should be rated for the maximum output current (I_{O-MAX}) plus the inductor ripple current (ΔI_L) to avoid saturation. The maximum inductor current (I_{L-MAX}) is given by:

$$I_{L-MAX} = I_{O-MAX} + \Delta I_L/2$$

Capacitor Selection

The small size of ceramic capacitors are ideal for EC3201S applications. X5R and X7R types are recommended because they retain their capacitance over wider voltage and temperature ranges than other types, such as Y5V or Z5U. A 4.7μF input capacitor and a 10μF output capacitor are sufficient for most EC3201S applications.

When selecting an output capacitor, consider the output ripple voltage and the ripple current. The ESR of capacitor is a major factor to the output ripple. For the best performance, a low ESR output capacitor is required. The ripple voltage is given by:

$$\Delta V_O = \Delta I_L [ESR + 1/(8 \times f \times C_O)]$$

Output Voltage Programming (Adjustable Voltage Version)

The output voltage of EC3201S is set by the resistor divider according to the following formula:

$$V_{OUT} = V_{FB} \times (1 + R1/R2)$$

R1 is the upper resistor of the voltage divider. For transient response reasons, a small feed-forward capacitor (C_F) is required in parallel to the upper feedback resistor, and 22pF is recommended.

Checking Transient Response

The regulator loop response can be checked by looking at the load transient response. Switching regulators take several cycles to respond to a step in load current. When a load step occurs, V_{OUT} will be shifted immediately by an amount equal to ($\Delta I_{LOAD} \times ESR$), where ESR is the effective series resistance of C_{OUT} . ΔI_{LOAD} will also begin to charge or discharge C_{OUT} , which generates a feedback error signal. Then the regulator loop will act to return V_{OUT} to its steady state value. During this recovery time, V_{OUT} can be monitored for overshoot or ringing that will indicate the stability problem.

The discharged bypass capacitors are effectively put in parallel with C_{OUT} , causing a rapidly drop in V_{OUT} . No regulator can deliver enough current to prevent this problem if the load switch resistance is low and it is driven quickly. The only solution is to limit the rise time of the switch drive, so that the load rise time will be limited to approximately ($25 \times C_{LOAD}$).

Package Information

TSOT23-5L

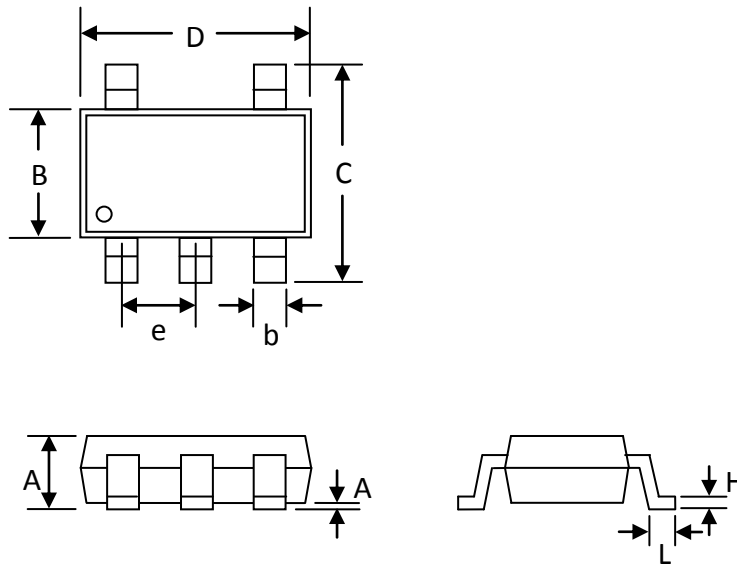

Symbol	Dimensions in mm		Dimensions in Inch	
	Min	Max	Min	Max
A	0.700	1.100	0.028	0.043
A1	0.000	0.130	0.000	0.005
B	1.500	1.700	0.059	0.067
b	0.300	0.559	0.012	0.022
C	2.500	3.100	0.098	0.122
D	2.800	3.100	0.110	0.122
e	0.950 BSC		0.037 BSC	
H	0.080	0.200	0.003	0.008
L	0.200	0.800	0.008	0.031

Package Information

TDFN 2x2-6L

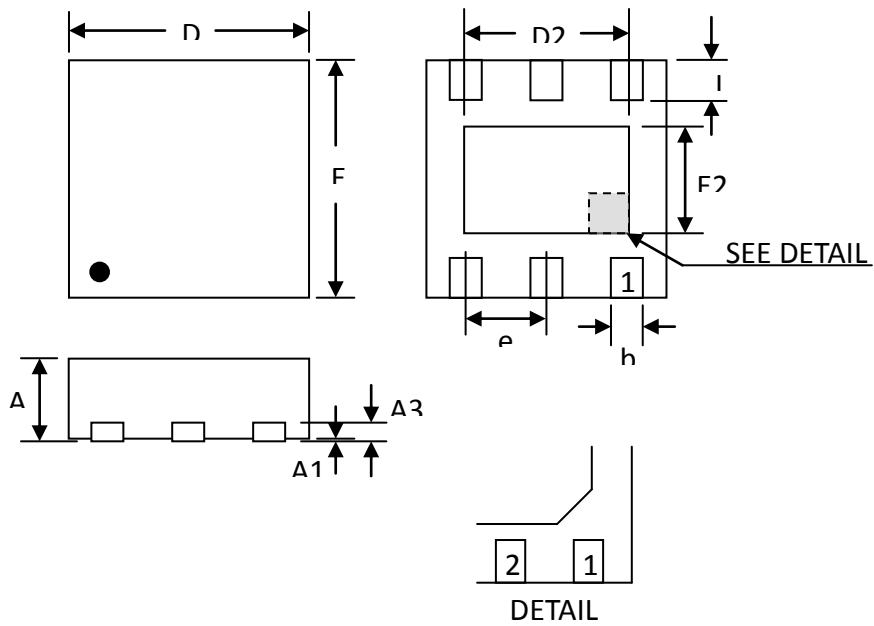

SYMBOLS	DIMENSION (MM)			DIMENSION (INCH)		
	MIN	NOM	MAX	MIN	NOM	MAX
A	0.700	---	0.800	0.028	---	0.031
A1	0.000	---	0.050	0.000	---	0.002
A3	0.175	---	0.250	0.007	---	0.010
b	0.200	---	0.350	0.008	---	0.014
D	1.950	2.000	2.050	0.077	0.079	0.081
D2	1.000	---	1.450	0.039	---	0.057
E	1.950	2.000	2.050	0.077	0.079	0.081
E2	0.500	---	0.850	0.020	---	0.033
e	0.650			0.026		
L	0.250	---	0.400	0.010	---	0.016