

TW2809C

Multichannel H.264 Audio/Video Codec

FN7875

Rev. 1.00

February 27, 2014

Features

TW2809C is a high performance and cost effective multi-channel H.264 codec solution designed for security surveillance market. It is capable of encoding and decoding maximum 8 channels standard definition (SD) video in real time. It can do high definition (HD) 1080x60i encode or decode at real time too. Each video channel can be independently controlled in terms of encode / decode mode, frame rate, bit rate, and resolution. TW2809C is an ideal H.264 codec candidate for different DVR platforms such as 16CH SD or 16CH CIF.

Video Features

- Real time full-duplex video codec compliant to H.264 main profile standard
- Supports real time full duplex 9 channel SD encode and/or decode
- Supports CIF JPEG or H.264 network stream encode
- Supports CBR and VBR
- Four video input ports compliant to BT.656 up to 108MHz
- Four video output ports compliant to BT.656 up to 108MHz
- Two video input ports compliant to BT.1120 at 74.25MHz
- Two video output ports compliant to BT.1120 at 74.25MHz

Audio Features

- Real time 16 channel encode and 1 channel decode compliant to ADPCM standard.
- Independent digital audio input and output I/F compliant to I^2S standard
- Audio sample rate from 8kHz to 48kHz

Peripheral I/F

- External 16-bit DDR2 SDRAM @ 400MHz
- 32-bit PCI target for host communications @ 33/66MHz

Operating Voltage

- 1.2V for core
- 3.3V for I/O pad
- 1.8V for DDR2 DRAM I/O

Physical

- PBGA-320, 27mmx27mm, 1.27mm lead pitch
- 1.2W power consumption

Table of Contents

TW2809 Register Definition Overview	18
TW2809 Memory Map	18
Interrupt Scheme.....	19
Interrupt register.....	19
Interrupt protocol.....	19
PCI Register Definitions	20
PCI Register 00.....	21
PCI Register 04.....	21
PCI Register 08.....	22
PCI Register 0c.....	22
PCI Register 10-24.....	23
PCI Register 28.....	23
PCI Register 2c.....	24
PCI Register 30.....	24
PCI Register 34.....	25
PCI Register 38.....	25
PCI Register 3c.....	26
Pin Mux Register Definitions	27
UART Pin Mux Configuration.....	27
Descriptions.....	27
GPIO[7:0] Pin Mux Configuration	28
Descriptions.....	28
GPIO[15:8] Pin Mux Configuration.....	29
Descriptions.....	29
GPIO[23:16] Pin Mux Configuration	30
Descriptions.....	30
GPIO[31:24] Pin Mux Configuration	31
GPIO[39:32] pin mux configuration	32
Descriptions.....	32
GPIO[47:40] Pin Mux Configuration	33
Descriptions.....	33
GPIO[55:48] pin mux configuration	34
Descriptions.....	34
PDMA Register Definitions	35
Master Mode	35
PDMA Interrupt Status Register for FW.....	35
Descriptions.....	36
PDMA Master TX and RX Interrupt Status Register (optional).....	36
Descriptions.....	36
PDMA Master TX and RX Endian Control Register	37
Descriptions.....	37
PDMA Master TX Control Register	38
Descriptions.....	38
PDMA Master TX Buffer ID Register	38
Descriptions.....	38
PDMA Master TX Target Start Address Register	39
Descriptions.....	39
PDMA Master TX Total Length Register.....	39
PDMA Master TX 2D XY Start Register	39
PDMA Master RX Control Register	40
Descriptions.....	40
PDMA Master RX Buffer ID Register	40
Descriptions.....	40

PDMA Master RX Source Start Address Register.....	41
Descriptions.....	41
PDMA Master RX Total Length Register	41
PDMA Master RX 2D XY Start Register.....	41
Slave Mode	42
PDMA Slave TX Control Register.....	42
Descriptions.....	42
PDMA Slave TX Buffer ID Register.....	43
Descriptions.....	43
PDMA Slave TX Total Length Register	43
Descriptions.....	43
PDMA Slave TX 2D XY Start Register	44
PDMA Slave RX Control Register	44
Descriptions.....	44
PDMA Slave RX Buffer ID Register	45
Descriptions.....	45
PDMA Slave RX Total Length Register.....	45
Descriptions.....	45
PDMA Slave RX 2D XY Start Register	45
PDMA Slave Interrupt Status Register	46
Descriptions.....	46
Communication Between FW and Host.....	47
The Communication Command Register from Host Driver	47
Descriptions.....	47
The first Extra Communication Register from Host Driver	47
Descriptions.....	47
The Second Extra Communication Register from Host Driver	48
The Communication Command Register from FW	48
Descriptions.....	48
The First Extra Communication Register from FW.....	49
Descriptions.....	49
The Second Extra Communication Register from FW	49
Descriptions.....	49
Interrupt Status for PCI Host Driver	50
PDMA Interrupt Status Register for PCI channel	50
Descriptions.....	51
Global Control Register Definitions	51
Normal Interrupt.....	51
Descriptions.....	51
Codec Video Channel	52
Descriptions.....	52
Software Reset	53
Description	54
Timer Period Register	55
Descriptions.....	55
Encode Mode Register.....	55
Fast Interrupt.....	56
Descriptions.....	56
Encoder Parameter Register 0.....	57
Encoding Parameter Register 1.....	57
Encoder Parameter Register 2.....	58
Encoder Parameter Register 3.....	58
Timer 0 Count	59
Timer 1 Count	59
Timer 2 Count	59
Timer 3 Count	59

Encoder Parameter Register 4.....	60
Encoder Parameter Register 5.....	60
Encoder Parameter Register 6.....	61
Encoder Parameter Register 7.....	61
Encoder Parameter Register 8.....	61
Encoder Parameter Register 9.....	62
Encoder Parameter Register 10.....	62
Encoder Parameter Register 11.....	63
Encoder Parameter Register 12.....	63
Watch Dog Limit.....	63
Timer Control Register.....	64
Descriptions.....	64
Timer 1 Control Register.....	65
Timer 2 Control Register.....	65
Timer 3 Control Register.....	66
Host Interface Register Definitions.....	67
HIF Interrupt.....	67
Descriptions.....	67
Device ID 68.....	
PCI Class Code.....	68
PCI Sub-system ID.....	69
PCI Header Info.....	69
DDR Mode Register.....	70
DDR Timing Control Register 0.....	72
Descriptions.....	72
DDR Timing Control Register 1.....	72
Descriptions.....	72
FW PDMA Control Register.....	73
FW PDMA Command Register.....	73
I2C Register Definitions.....	74
I2C Interrupt Register.....	74
Descriptions.....	74
I2C Mode Select Register.....	75
Descriptions.....	75
I2C Write Register0, Register1, Register2, Register3.....	75
Descriptions.....	75
I2C Write Register4, Register5, Register6, Register7.....	76
Descriptions.....	76
I2C Write Register8, Register9, Register10, Register11.....	76
Descriptions.....	76
I2C Write Register12, Register13, Register14, Register15.....	77
Descriptions.....	77
I2C Write Register16, Register17, Register18, Register19.....	77
Descriptions.....	77
I2C Write Register20, Register21, Register22, Register23.....	78
Descriptions.....	78
I2C Write Register24, Register25, Register26, Register27.....	78
Descriptions.....	78
I2C Write Register28, Register29, Register30, Register31.....	79
Descriptions.....	79
I2C Read Register0, Register1, Register2, Register3.....	79
Descriptions.....	79
I2C Read Register4, Register5, Register6, Register7.....	80
Descriptions.....	80
I2C Read Register8, Register9, Register10, Register11.....	80
Descriptions.....	80

I2C Read Register12, Register13, Register14, Register15	81
Descriptions.....	81
I2C Read Register16, Register17, Register18, Register19	81
Descriptions.....	81
I2C Read Register20, Register21, Register22, Register23	82
Descriptions.....	82
I2C Read Register24, Register25, Register26, Register27	82
Descriptions.....	82
I2C Read Register28, Register29, Register30, Register31	83
Descriptions.....	83
I2C Master Mode Protocol	84
Write CBUS 32 bit registers:	84
Read CBUS 32 bit registers:	84
UART Register Definitions	86
UART Interrupt Enable Register	86
Descriptions.....	86
UART Interrupt Status Register	86
Descriptions.....	86
UART Line Control Register(LCR)	87
Descriptions.....	87
UART Divisor Latch Byte 1 Register(LSB)	88
Descriptions.....	88
UART Divisor Latch Byte 2 Register (MSB).....	89
Descriptions.....	89
UART Internal Interrupt Enable Register(IER)	90
Descriptions.....	90
UART Interrupt Identification Register(IIR).....	91
Descriptions.....	91
UART FIFO Control Register(FCR).....	92
Descriptions.....	92
UART Modem Control Register(MCR).....	93
Descriptions.....	93
UART Line Status Register(LSR)	94
Descriptions.....	95
UART Modem Status Register(MSR)	96
Descriptions.....	96
UART Receiver Buffer.....	97
Descriptions.....	97
UART Transmitter Holding Register	97
Descriptions.....	97
GPIO Register Definitions.....	98
GPIO Interrupt Enable Register	98
Descriptions.....	98
GPIO Interrupt Status Register	99
Descriptions.....	99
GPIO Line Driving Register0	99
Descriptions.....	99
GPIO Line Driving Register1	100
Descriptions.....	100
GPIO Line Control Register0	100
Descriptions.....	100
GPIO Line Control Register1.....	101
Descriptions.....	101
GPIO Line Load Register0	101
Descriptions.....	101
GPIO Line Load Register1	102

Descriptions	102
Peripheral Timing	103
UART Interface	113
DDR2 Timing	114
Power Up Sequence	118
Power Off Sequence	118
Electrical Specifications	119
Absolute Maximum Ratings	119
Recommended Operating Conditions	119
Supply Current and Power Dissipation	119
DC Characteristics	120
Input / Output Capacitance	120
Package Description	121
Ball Assignment	121
Pin Definitions	122
Mechanical Specifications	130

Ordering Information

PART NUMBER	PART MARKING	PACKAGE (Pb-free)
TW2809-BC1-GR (Note 1)	TW2809 PKBC1-GR	320 Ld 27mm x 27mm PBGA

NOTE:

1. These Intersil Pb-free WLCSP and BGA packaged products employ special Pb-free material sets; molding compounds/die attach materials and SnAgCu - e1 solder ball terminals, which are RoHS compliant and compatible with both SnPb and Pb-free soldering operations. Intersil Pb-free WLCSP and BGA packaged products are MSL classified at Pb-free peak reflow temperatures that meet or exceed the Pb-free requirements of IPC/JEDEC J STD-020.

General Description

TW2809C is a highly integrated multi-channel H.264 codec targeting security surveillance market. The video codec is designed to work in full duplex mode so it is capable of doing digital video compressing and de-compressing simultaneously. TW2809C uses a tightly pipelined hardware solution to guarantee its performance benchmark. The embedded ARM926 microprocessor enables TW2809C to tailor various customized sets of functions such as various bit rates, different frame rates, and different resolutions for each channel. Customers can change TW2809C configuration parameters to meet their own needs. These parameters includes video channel number, bit rate, frame rate, NTSC/PAL, progressive/interleave mode, encode/decode mode, etc.

Peripheral Interface

TW2809C implements a few peripheral interfaces: video capture, video display, audio I/F, memory I/F, and PCI I/F. These interfaces are described in more details in this section.

VIDEO INPUT I/F

SD Video Input I/F

There are four independent SD video input ports with their own clock. The video input format is compliant to BT.656. Each port can take frame interleaved video input @ 27MHz, 54MHz, or 108MHz.

Video input port 0 is a special port. In addition to frame interleaved video input, it also takes 108MHz or 54MHz byte-interleaved video input. It can directly connect to TW2866-alike video decoder and receive 4 channel SD video inputs. Video input port 2 is also a special port. It can take 54MHz byte-interleaved video input. It can be used together with input port 0 to take 4 channel SD video inputs from TW2866-alike video decoder with two 54MHz input clocks.

HD Video Input I/F

There are two independent HD video input ports with their own clock. The video input format is compliant to BT.1120. Each port can take one HD video input @ 74.25MHz.

VIDEO OUTPUT I/F

SD Video Output I/F

There are four video output ports. Port 0 and port 1 share the same video output clock. Port 2 and port 3 share the same video output clock. Each port can output frame interleaved video @27MHz, 54MHz, or 108MHz.

HD Video Output I/F

There are two independent HD video output ports with their own clock. The video output format is compliant to BT.1120. Each port can send one HD video input @ 74.25MHz.

AUDIO I/F

The codec has two sets of digital audio I^2S interface. One is the audio input interface operating as slave mode. The other is the audio output interface operating as master mode.

DDR I/F

The external DDR2 SDRAM is used as memory for storing video and audio information during encoding and decoding processes. The codec supports 1Gb DDR2 SDRAM with 16-bit data bus.

PCI I/F

TW2809C uses PCI bus to communicate with the host. The bitstream from encoder output is stored to the hard disk via the PCI bus. The encoded bitstream is transferred to TW2809C decoder via PCI bus in the playback mode. The PCI clock can be either 33MHz or 66MHz.

Top Level Block Diagram

Figure 1 shows the top level codec block diagram. The ARM926 handles both A/V synchronization and slice-layer-above video processing. The major video codec task is done by the tightly coupled macroblock video pipeline. There is an internal 64-bit memory data bus connecting most of the codec modules with the external DDR2 memory. The ARM processor has AHB bus interface. The codec implements its own internal 32-bit control bus for global on-chip register access. There is an interface bridge to convert AHB protocol to the internal control bus. The external memory interface needs to operate at 400MHz in order to provide enough bandwidth.

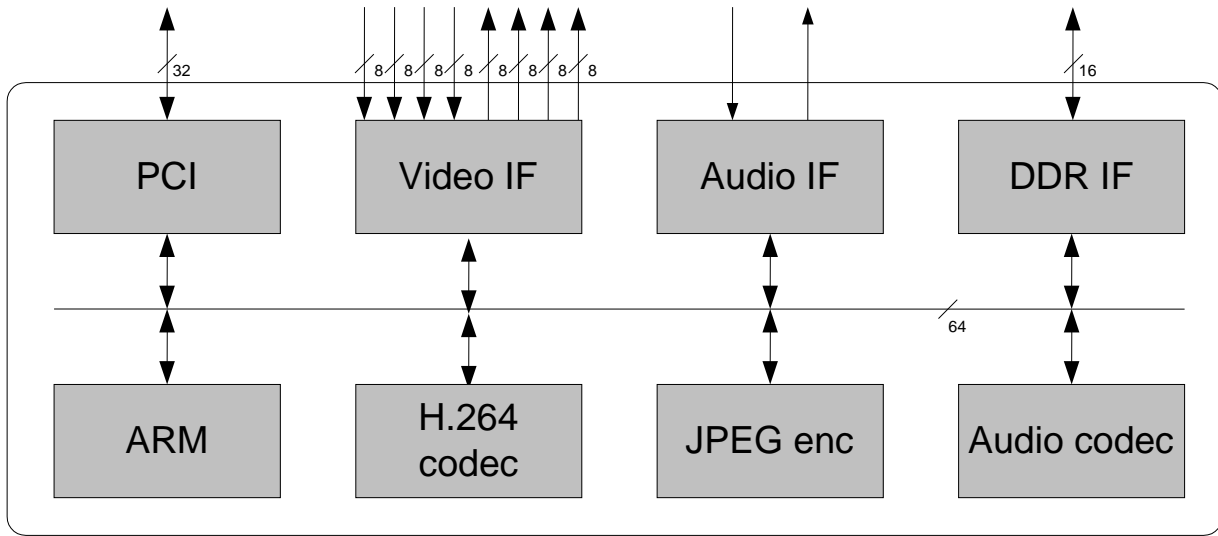

FIGURE 1. TW2809C BLOCK DIAGRAM

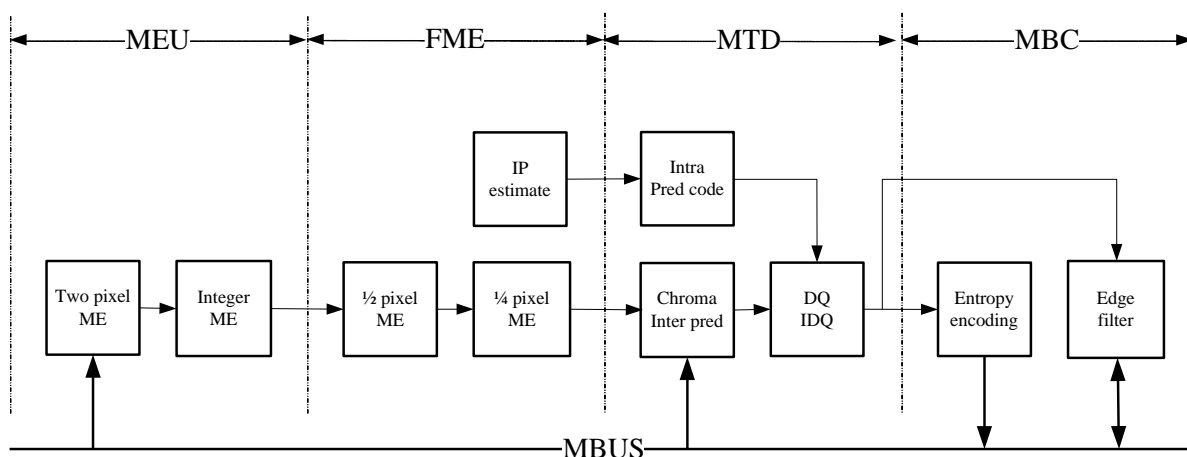

FIGURE 2. ENCODER HW PIPELINE

ENCODING BLOCK DIAGRAM

TW2809C hardwired video encoder is designed to compress a sequence of YUV 4:2:0 pictures to a single compressed video bitstream. It supports various resolutions from CIF (352x240) to HD (1920x1080). The motion vector is in $\frac{1}{4}$ pixel accuracy. All intra-prediction modes are supported. The firmware in the embedded microprocessor is responsible for rate control scheme, such as CBR and VBR. In the CBR mode, the QP value can be adjusted at each macroblock. The visual subjective video quality is improved by implementing programmable in-loop filter.

The video encoding is divided into a series of processing steps for each 16x16 macroblock for each video frame. The initial step is to generate the prediction for the current macroblock. There are two kinds of predictions: intra prediction (spatial prediction using encoded current pix) and inter prediction (temporal prediction using previously encoded pictures). The residual difference between current block and the predicated block goes through transformation and then quantized. The results will be coded into H.264 bitstream using content adaptive variable length coding (CAVLC) method. Meanwhile, the reconstructed macroblock is calculated by applying inverse quantization and transformed to the quantized coefficients. An in-loop de-blocking filter is applied to the reconstructed macroblock before it is stored in the reference frame buffer.

The H.264 encoding requires many of its operation in sequence, which imposes a computation challenge for ASIC design. In order to meet this challenge, the codec simplifies certain parts of sequence operation into parallel operation without introducing noticeable artifacts. A macroblock level pipeline is implemented in TW2809C to break down one macroblock processing it into smaller tasks and making it easier for hardware implementation. As shown in Figure 2, the macroblock pipeline consists of 4 stages: the motion estimation unit (MEU), the fractional motion estimation (FME), macroblock type decision (MTD), and macroblock coding (MBC). Each stage has to complete all assigned tasks within one macroblock processing period.

Each macroblock pipeline can be further partitioned into several sub-blocks. During the encoding process, all four macroblock pipelines are concurrently processing 4 consecutive macroblock data in raster-scan order. Figure 3 illustrates encoding macroblock pipeline schedule in the time domain.

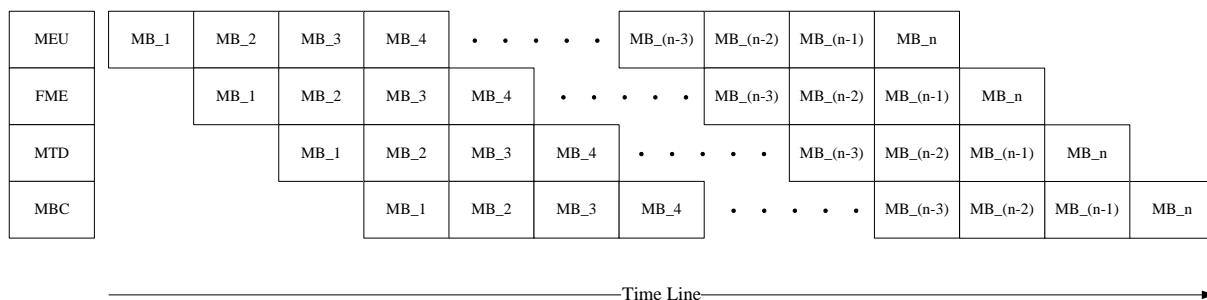

FIGURE 3. ENCODER MACROBLOCK PIPELINE SCHEDULE

For each of these processes, the ARM must set up parameters and monitor events communicated by interrupts. The microprocessor involvement is limited, in the normal operation mode, to the slice-layer-above processing with the exception of video bit rate control. The rate control adjusts the quantization value at macroblock level.

DECODING BLOCK DIAGRAM

The major video decompression task is done by the tightly coupled macroblock pipeline that consists of variable length decoding (VLD), block transform unit for idct/iq (BTU), intra/inter prediction (IPD), and edge filter (EGF).

The decoding macroblock pipeline is able to decode in its entirety a video bitstream from slice layer downwards. The ARM must decode the higher layers in order to extract the information needed for decoding and appropriately set up the registers.

The codec implements a start code detector that is a few slices in advance of macroblock decoding pipeline. This start code detector parses the bitstream and locates start codes corresponding to slice layer and above. When one of these start-codes is found, the start code detectors stops and raises an interrupt to the ARM. The ARM is then able to read the header data following the start code. The decoded header parameters will be programmed into hardware shared parameter data structure that will be discussed in detail later in this document.

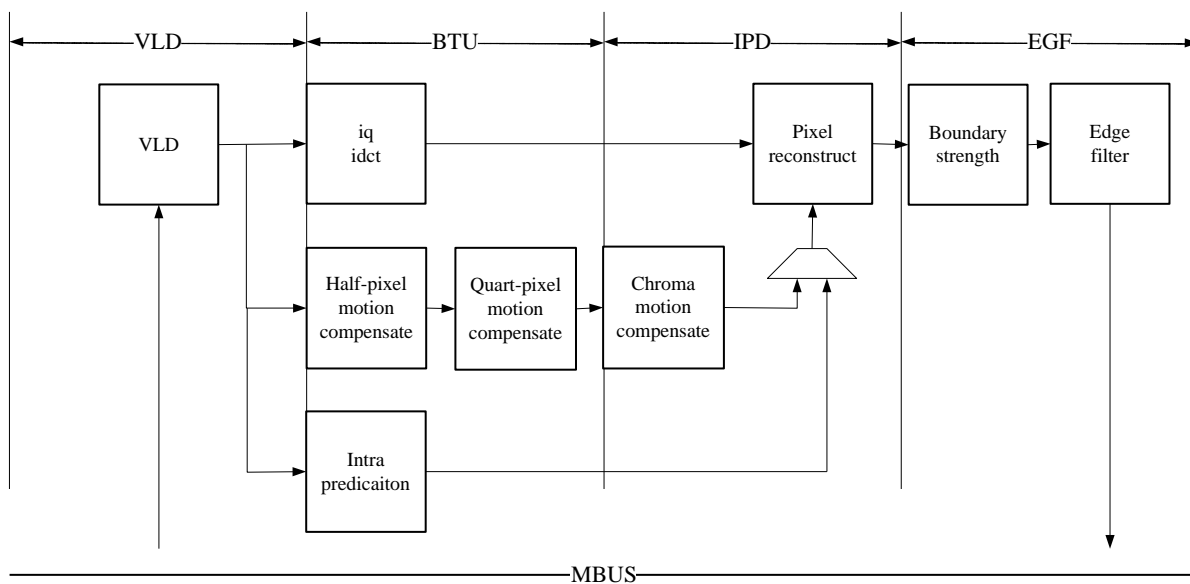

FIGURE 4. DECODER BLOCK DIAGRAM

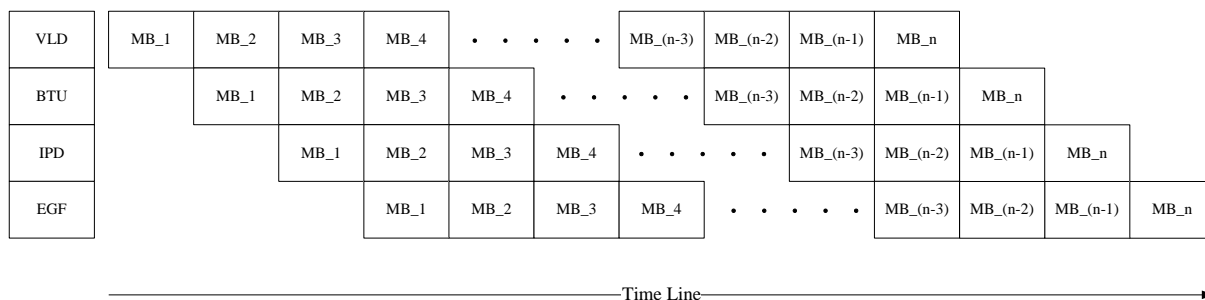

FIGURE 5. DECODER MACROBLOCK PIPELINE SCHEDULE

Video Configuration and Interfaces

TW2809C can be configured differently for its video codec operation. Customers can set resolution and frame rate differently for primary and secondary video channels. This section provides guidelines for the customer to configure TW2809C video correctly.

Primary Video Stream

There are some limitations for TW2809C primary video processing. Customers should be careful not to violate any of these limitations.

TW2809C MAXIMUM VIDEO PROCESSING POWER

TW2809C can do real time 8 channel SD codec (4 Enc + 4 Dec). It can also do real time 32 channel CIF codec (16Enc + 16Dec). In other words, TW2809C can process up to 240 SD frames in a second. Customers can assign any 240 frames to any video channel for either encode or decode. For example, the user can use all 240 frames for encoding tasks so that TW2809C operates as 8SD encoding mode. The user can also use all 240 frames for decoding tasks so that TW2809C operates as 8SD decoding mode. The user can use 120 frames for encoding tasks and remaining 120 frames for decoding tasks. Then TW2809C works as 4SD encode and 4SD decode. Customers can use a single SD computation power for *roughly* four CIF picture processing. It is not exactly four CIF picture considering firmware overhead to handle four CIF pictures instead of one SD picture.

TW2809C MAXIMUM VIDEO CHANNEL NUMBER

The maximum primary video channel number is 32. This is an internal architecture limit for TW2809C. Thus it is impossible for TW2809C to support 64 CIF codec @15fps, even though the

computation power is almost the same as 32 CIF codec @30fps.

TW2809C MAXIMUM EXTERNAL FRAME BUFFER NUMBER

The user should be aware that external frame buffer size is decided by the resolution of the video channel. It has nothing to do with the frame rate. For example, the frame buffer size for two SD @15fps is two times larger than one SD @30fps, even though the computation power remains roughly the same. With 1Gb DDR as external memory, there is a limitation of maximum frame buffer number.

Network Secondary Video Stream

TW2809C supports network stream encoding. The performance benchmark for network stream is different for SD and CIF case. For 8 CH SD DVR (4 Enc + 4 Dec), TW2809C is capable of encoding 4 real time CIF secondary video stream. However there is not much computation power reserved for secondary video stream for 32 CH CIF DVR (16 Enc + 16 Dec). If the user needs to encode 16 real-time QCIF secondary video stream, the decoding channel number has to be reduced from 16 to 8 in order to provide sufficient computer power.

Video Input Description

TW2809C implements 4 physical input ports. These four input ports can be configured to take SD video inputs. TW2809C takes either frame or byte interleaved video input format. But users cannot assign some video input ports to frame interleaved format and the remaining video input ports to byte interleaved format.

Video input port 0 and 1 or port 2 and 3 can be configured to receive HD video input. It is possible for TW2809C to take mixed HD and SD input format. For example, TW2809C can receive SD

video input on port 2 and 3. At the same time, TW2809C can receive HD video input on port 0 and 1.

VIDEO INPUT LOGIC PORTS

There are some limitations on how to use TW2809C physical ports for SD or HD video inputs.

1) Four input ports at frame interleaved mode:

@27/54/108MHz. Use port 0-3

port-0: {vi0_data[7:0]} clk_vi0 @ 27/54/108MHz

port-1: {vi1_data[7:0]} clk_vi1 @ 27/54/108MHz

port-2: {vi2_data[7:0]} clk_vi2 @ 27/54/108MHz

port-3: {vi3_data[7:0]} clk_vi4 @ 27/54/108MHz

1)2) Two input ports at byte interleaved mode

@54MHz. Use port-0 and port-2

port-0: {vi0_data[7:0]} clk_vi0 @ 54MHz

port-2: {vi2_data[7:0]} clk_vi2 @ 54MHz

3) One input port at byte interleaved mode @

108MHz. Use port-0

port-0: {vi0_data[7:0]} clk_vi0 @ 108MHz

BT.656 FRAME INTERLEAVED VIDEO INPUT

The frame interleaved case is rather simple. Each TW2809C video input port can operate up to 108MHz. The clocks of four ports are independent from each other. For example, the user can feed two channel video inputs to port 0 at 54MHz. At the same, the user can also feed one channel video input to port 1 at 27MHz. For 8SD encoding only case, TW2809C accepts up to 8 SD video inputs.

BT.656 BYTE INTERLEAVED 54MHz VIDEO INPUT

Video input port 0 and port 2 can take 54MHz byte interleaved video input. When port 0 is used for 54MHz video input, port 1 cannot connect to any video input.

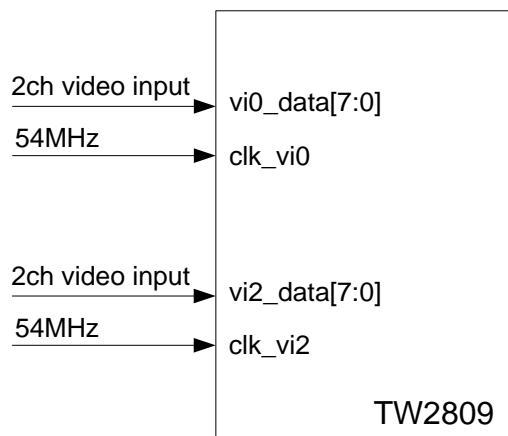

FIGURE 6 . BYTE-INTERLEAVE 54MHz VIDEO INPUT TOP LEVEL DIAGRAM

When port 2 is used for 54MHz video input, port 3 cannot connect to any video input.

BT.656 BYTE INTERLEAVED 108MHz VIDEO INPUT

Video port 0 is the only port that accepts 108MHz byte interleaved video input. When port 0 is used for 108MHz video input, all other three video input ports cannot connect to any video input.

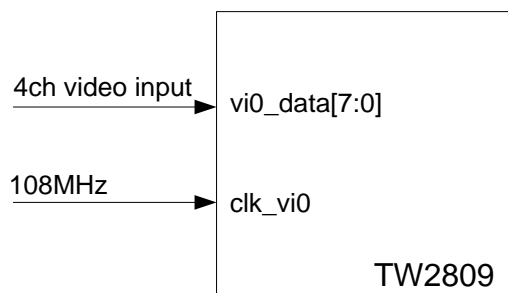

FIGURE 7 . 108MHz BYTE-INTERLEAVE VIDEO INPUT TOP LEVEL DIAGRAM

BT.1120 HD VIDEO INPUT

TW2809C is designed to take two channel HD video inputs. As shown in the following figure, video physical input ports 0 and 1 can be grouped together to receive one HD video input. The HD video input clock is connected to pin *clk_vi0*. It is noted that video input port 0 and 1 should be connected to HD luma and chroma ports respectively.

Physical video input ports 2 and 3 can be used to receive another HD video input similar as video input port 0 and 1.

TW2809C is capable of encoding one channel 1080x60i in real time. It can encode two channel 1080x60i in half of real time frame rate.

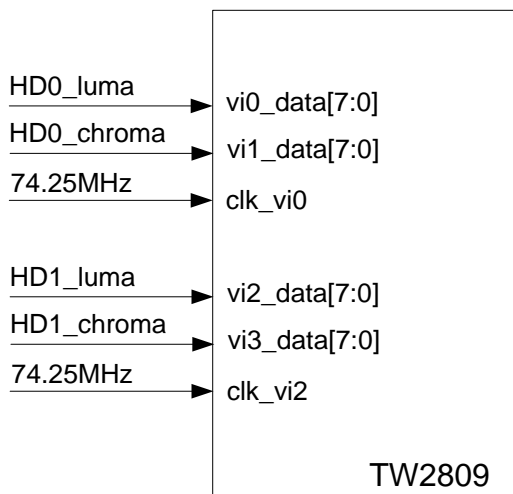

FIGURE 8. BT.1120 HD INPUT DIAGRAM

SD/HD MIXED VIDEO INPUT

TW2809C can take HD and SD video input at the same time. The max encode performance benchmark is 1ch HD plus 2ch SD video encode at real time. Picture 9 shows one configuration to use video input port *vi2* (@54MHz) to take 2ch SD in frame-interleaved format. Another configuration is to use two video input port *vi2* and *vi3* (@27MHz) to take 2ch SD video.

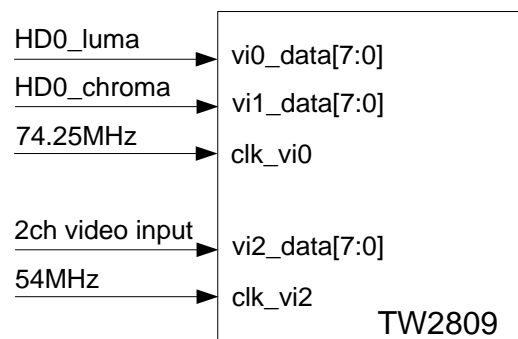

FIGURE 9. HD/SD MIXED VIDEO INPUT MODE

Video Output Description

There are four video output ports and two clocks for the four ports. Video output port 0 and port 1 share *vo_clk_0*. Video output port 2 and port 3 share *vo_clk_1*.

VIDEO OUTPUT LOGIC PORTS

[Four output ports](#) at frame interleaved mode: @ 27/54/108MHz. Use [port 0-3](#)

[port-0: {vo0_data\[7:0\]} clk_vo_out_0 @ 27/54/108MHz](#)

[port-1: {vo1_data\[7:0\]} clk_vo_out_0 @ 27/54/108MHz](#)

[port-2: {vo2_data\[7:0\]} clk_vo_out_1 @ 27/54/108MHz](#)

[port-3: {vo3_data\[7:0\]} clk_vo_out_1 @ 27/54/108MHz](#)

BT. 656 FRAME INTERLEAVED VIDEO OUTPUT

TW2809C output port only supports frame interleave video format. It does not support byte-interleave video format. Video output port 0 and port 1 shares same output clock *vo_clk_0*. Video output port 2 and port 3 shares same output clock *vo_clk_1*. The two video output clocks are independent of each other.

BT.1120 VIDEO OUTPUT

TW2809C physical video output port 0 and 1 can be grouped together to send one channel HD video data out. It is noted that video output port 0 and 1 is designed to output HD luma and chroma data respectively.

The other two video output ports 2 and 3 can be grouped together to send another channel HD video data out similar to port 0 and 1.

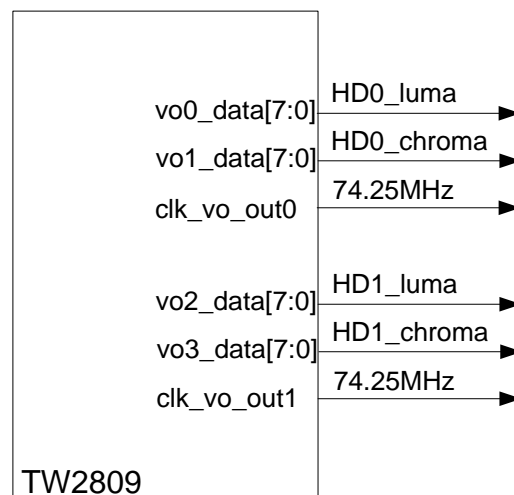

FIGURE 10. HD VIDEO OUTPUT

TW2809C is capable of decoding one channel 1080x60i in real time. It can also encode and decode one channel HD video (full duplex) in about 4/5 of real time frame rate.

CHANNEL MUXED VIDEO OUTPUT

TW2809C has limited video mux function and can assemble 4CIF video into 1SD format and send it

to the video display. It can also assemble 6SD video into 1HD format and send it to TW2880 HD playback port. Each video output port has up-scalar function to take decoded CIF video and display it in SD format.

Four CIF Video Output Mux

TW2809C is capable of decoding multiple compressed CIF videos and assemble them into a single SD format to display.

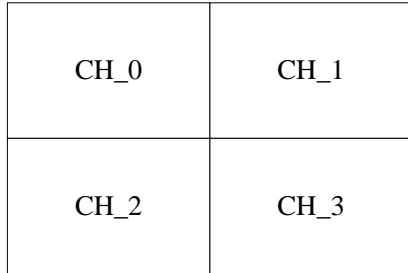

FIGURE 11. CIF VIDEO OUTPUT ASSEMBLER

As shown in the above figure, four channels of the CIF video are put together and sent to display in a single SD frame. Where the top field of the SD frame consists of video from channel 0 and channel 1, and bottom field of the SD frame consists of video from channel 2 and channel 3. If there are less than 4 channels of CIF video decoded, TW2809C will fill the unused channel with a pre-programmed color.

Mixed Resolution Video Output Mux

VOUT is flexible to assemble different video resolutions from different channels. As shown in the following figure, two CIF video and one half SD video are put together and sent to display in a single SD frame.

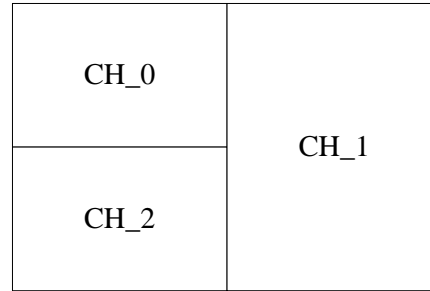

FIGURE 12. CIF/HALFSD VIDEO OUTPUT ASSEMBLER

VOUT implements on-the-fly up-scalar function to upsize a CIF video into a SD format and send to display. The horizontal direction is a bi-linear up-scalar. The bottom field is just a duplication of the top field.

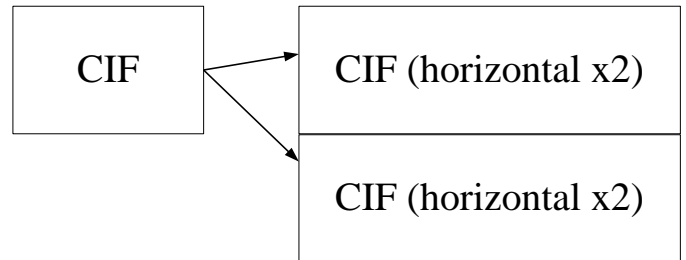

FIGURE 13. VOUT UP-SCALAR

In the time domain, different resolutions of video from different channels can be assembled together and sent to the display. The following figure illustrates on possibility for the VOUT case. It assembles 12 channels video with different resolutions and composes a single BT 656 video display stream.

The VOUT assembler is limited by its though-put upper limit, i.e., 8 SD video. If each CIF video channel needs to be upsized to SD resolution for the output, then only 8 CIF video can be displayed.

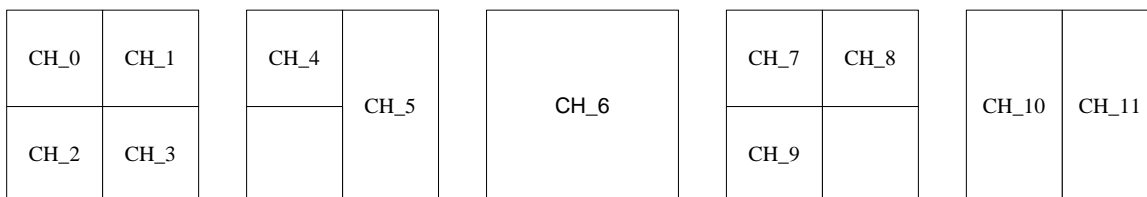

FIGURE 14. EXAMPLE OF TW2809C DISPLAY ORDER

Audio Processing

The audio processing unit (APU) handles audio compression and de-compression. For simple speech codec, there is no need to support multi-format audio compression; instead a single ADPCM format codec is implemented using hardware approach.

ADPCM is a variant of DPCM that varies the size of the quantization step, to allow further reduction of the required bandwidth for a given signal to noise ratio. It is used to map a series of 8-bit μ -law (or a-law) PCM samples into a series of 4 bit ADPCM samples (The ADPCM compression ratio is 4:1, but TW2809C will take each 8 bit sample and extend it to 16-bit before compression).

The audio compressed bitstream is packed into packets. The size of each packet is 188 Bytes with an embedded 28-bit packet header. The actual audio compressed bitstream size is 1476-bit or 369 audio samples.

I²S Protocol

The I²S bus is a serial bus consisting of three lines: serial clock, word selection, and serial data. The digital audio input interface is working as slave mode. The digital audio output interface is working as master mode. The codec shall generate both serial clock and word select when it operates as master mode. It receives both serial clock and word select when it operates as slave mode.

FIGURE 16. MULTI-CHANNEL DIGITAL AUDIO INTERFACE

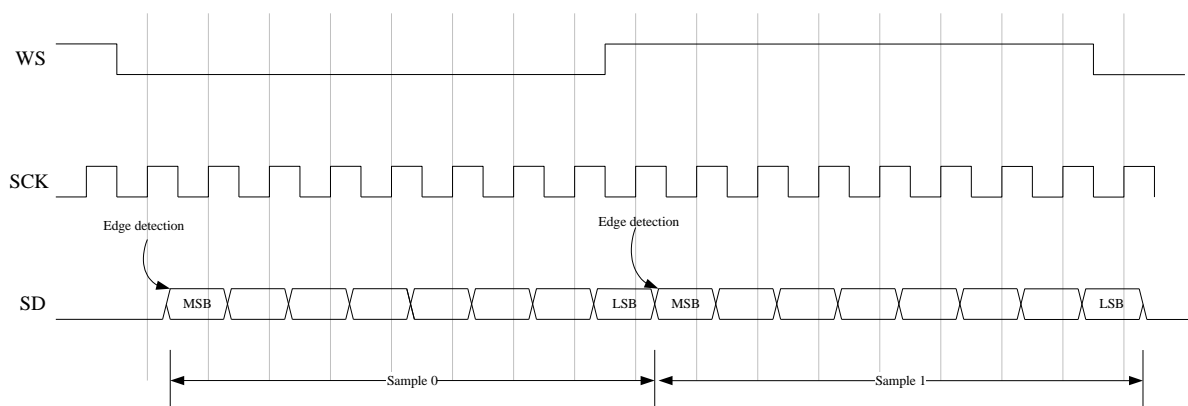

FIGURE 15. I²S PROTOCOL

The codec uses two set I²S pins to transmit or receive multi-channel digital audio data.

Multi-channel Audio Protocol

The serial clock (*sck*) depends on audio sample rate, audio sample bit width, and how many audio channels are occupied for current configuration. Different audio channel may have different sample rate and sample bit width. In order to simplify the audio codec design, the following equation is used to calculate the audio serial clock.

$$Sck = 256 \times \text{sample_rate}_{Max}$$

(EQ. 1) Equation 1 Audio Serial Clock

While *sample_rate_{Max}* is the maxima audio sample rate among all. For example, the serial clock should be 2,048kHz if max audio sample rate is 8kHz. In the above equation, it is assumed that each word select cycle covers 64-bits. The codec audios are all mono channel. There is no need for the codec to support stereo audio. The audio channels are evenly divided to fit into left and right channel space.

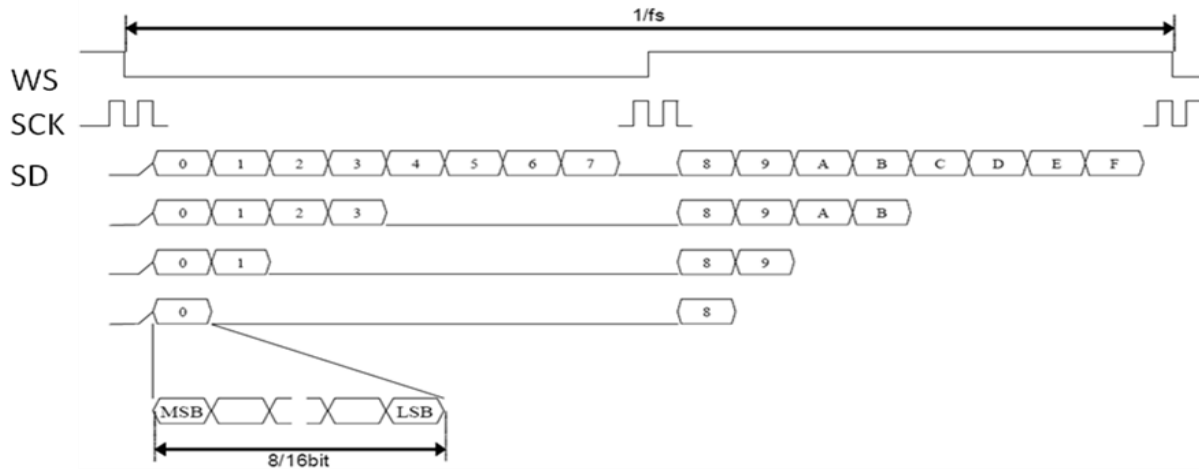

Figure 16 shows an example of multi-channels digital audio input protocol. It is noted that only first 4 bits after word select transition are valid. The remaining bits in the word select are not used.

TW2809 Register Definition Overview

TW2809 Memory Map

TW2809 memory map is partitioned into two distinct segments: one for the external DDR memory and the other for on-chip global control registers.

TABLE 1. SOC MEMORY MAP

	start_address	end_address
MBUS	32'h0000_0000	32'h3FFF_FFFF
CBUS	32'h8000_0000	32'h8000_1FFF

The external DDR access supports both single cycle and burst type. ARM926EJS burst length is always 32 bytes. The CBUS supports up to 20 clients with each client takes 256 Byte space. The following table shows current CBUS memory map.

TABLE 2. CBUS MEMORY MAP

MODULE NAME	START ADDRESS	END ADDRESS
DBG	32'h8000_0000	32'h8000_00FF
SPR	32'h8000_0100	32'h8000_01FF
VLD	32'h8000_0200	32'h8000_02FF
IPD	32'h8000_0300	32'h8000_03FF
IT	32'h8000_0400	32'h8000_04FF
EGF	32'h8000_0500	32'h8000_05FF
VIF	32'h8000_0600	32'h8000_06FF
TSM	32'h8000_0700	32'h8000_07FF
TME	32'h8000_0800	32'h8000_08FF
RTB	32'h8000_0900	32'h8000_09FF
HPM	32'h8000_0A00	32'h8000_0AFF
MBC	32'h8000_0B00	32'h8000_0BFF
VLC	32'h8000_0C00	32'h8000_0CFF
DCM	32'h8000_0D00	32'h8000_0DFF
HIF	32'h8000_0E00	32'h8000_0EFF
CTR	32'h8000_0F00	32'h8000_0FFF
GPIO	32'h8000_1C00	32'h8000_1CFF
UART0	32'h8000_1D00	32'h8000_1DFF
UART1	32'h8000_1E00	32'h8000_1EFF
I2C	32'h8000_1F00	32'h8000_1FFF

Interrupt Scheme

The interrupt protocol is outlined in this section. By default, the first register of each hardware module should be the register that defines the interrupt enable and status for the module.

INTERRUPT REGISTER

Address module base address + 0x00

Type r/w

31	30	29	28	27	26	25	24	23	22	21	20	19	18	17	16
															status
15	14	13	12	11	10	9	8	7	6	5	4	3	2	1	0
															enable

[31:17] reserved

[16] status – interrupt status. HW set this bit to HIGH to initiate interrupt. FW write HIGH to clear interrupt

[15:1] reserved

[0] enable – interrupt enable. 0: interrupt disable. 1: interrupt enable. Default is 1.

INTERRUPT PROTOCOL

HW generates an interrupt signal to FW when the interrupt source exist and the interrupt is enabled by the FW. When FW detects the interrupt, it gets into interrupt service routine. When it is done, FW writes HIGH to the *status* bit to clear the interrupt. When HW detects that FW is writing 1 to *status* bit, it shall clear the interrupt source.

PCI Register Definitions

This section describes PCI module registers. Normally, any PCI core supports the following registers. TW2809 defines some value in the registers such as device ID, vendor ID, class code, and so on. If customers want to know more detail information, they can check the configuration space section in “PCI local Bus Specification” document.

31																16																15																0																00h																																
Device ID																Vendor ID																																																																																
Status																Command																																																04h																																
Class Code																Revision ID																																																08h																																
BIST								Header Type								Latency Timer								Cache Line Size																								0Ch																																																
Base Address Registers																																																																10h																																
																																																																14h																																
																																																																18h																																
																																																																1Ch																																
																																																																20h																																
																																																																24h																																
Cardbus CIS Pointer																																																																28h																																
Subsystem ID																																Subsystem Vendor ID																																																																2Ch
Expansion ROM Base Address																																																																30h																																
Reserved																																Capabilities Pointer																																																																34h
Reserved																																																																38h																																
Max_Lat								Min_Gnt								Interrupt Pin								Interrupt Line																								3Ch																																																

PCI Register 00

Address PCI Base address + 0x00

Type read only

31	30	29	28	27	26	25	24	23	22	21	20	19	18	17	16
Device ID															
15	14	13	12	11	10	9	8	7	6	5	4	3	2	1	0
Vendor ID															

[31:16] device id – It specifies TW2809 PCI device ID

Default value: 0x2809

[15:0] vendor id – It specifies TW2809 PCI vendor ID

Default value: 0x1719

PCI Register 04

Address PCI Base address + 0x04

Type read only

31	30	29	28	27	26	25	24	23	22	21	20	19	18	17	16
Status															
15	14	13	12	11	10	9	8	7	6	5	4	3	2	1	0
Command															

[31:16] Status – It specifies TW2809 PCI status: 66MHz capable, DEVSEL timing is

medium

Default value: 0x02A0

[15:0] Command – It specifies TW2809 PCI command: TW2809 use memory space only,

But no I/O space.

Default value: 0x0007

PCI Register 08

Address PCI Base address + 0x08

Type read only

31	30	29	28	27	26	25	24	23	22	21	20	19	18	17	16
Class Code															
15	14	13	12	11	10	9	8	7	6	5	4	3	2	1	0
Class Code								Revision ID							

[31:8] class code – It specifies TW2809 PCI class code

Default value: 0x048000

[7:0] Revision ID – It specifies TW2809 PCI revision ID

0: TW2809A1

1: TW2809B1

2: TW2809C1

PCI Register 0c

Address PCI Base address + 0x0c

Type read only

31	30	29	28	27	26	25	24	23	22	21	20	19	18	17	16
BIST								header type							
15	14	13	12	11	10	9	8	7	6	5	4	3	2	1	0
latency timer								cache line size							

[31:24] BIST – It specifies TW2809 PCI BIST

Default value: 0x00

[23:16] header type – It specifies TW2809 PCI header type

Default value: 0x00

[15:8] latency timer – It specifies TW2809 PCI latency timer

Default value: 0x00

[7:0] cache line size – It specifies TW2809 PCI cache line size

Default value: 0x00

PCI Register 10-24

Address PCI Base address + 0x10 - 0x24

Type read only

31	30	29	28	27	26	25	24	23	22	21	20	19	18	17	16
Base address registers															
15	14	13	12	11	10	9	8	7	6	5	4	3	2	1	0

Register 10 (Bart #0) - TW2809 has 64K byte memory space

Register 14 (Bart #1) - Reserved

Register 18 (Bart #2) - Reserved

Register 1c (Bart #3) - Reserved

Register 20 (Bart #4) - Reserved

Register 24 (Bart #5) - Reserved

PCI Register 28

Address PCI Base address + 0x28

Type read only

31	30	29	28	27	26	25	24	23	22	21	20	19	18	17	16
Cardbus CIS Pointer															
15	14	13	12	11	10	9	8	7	6	5	4	3	2	1	0

[31:0] Cardbus CIS Pointer - It specifies TW2809 PCI Cardbus CIS pointer

Default value: 0x00

PCI Register 2c

Address PCI Base address + 0x2c

Type read only

31	30	29	28	27	26	25	24	23	22	21	20	19	18	17	16
Subsystem ID															
15	14	13	12	11	10	9	8	7	6	5	4	3	2	1	0
Subsystem Vendor ID															

[31:16] Subsystem id – It specifies TW2809 PCI subsystem ID

Default value: 0x2809

[15:0] Subsystem vendor id – It specifies TW2809 PCI subsystem vendor ID

Default value: 0x1719

PCI Register 30

Address PCI Base address + 0x30

Type read only

31	30	29	28	27	26	25	24	23	22	21	20	19	18	17	16
Expansion ROM Base Address															
15	14	13	12	11	10	9	8	7	6	5	4	3	2	1	0

[31:0] Expansion ROM base address – It specifies TW2809 PCI expansion ROM base address

Default value: 0x00

PCI Register 34

Address PCI Base address + 0x34

Type read only

31	30	29	28	27	26	25	24	23	22	21	20	19	18	17	16
Reserved															
15	14	13	12	11	10	9	8	7	6	5	4	3	2	1	0
Reserved								Capabilities pointers							

[31:8] Reserved

[7:0] Capabilities pointer – It specifies TW2809 PCI capabilities pointer

Default value: 0x00

PCI Register 38

Address PCI Base address + 0x38

Type read only

31	30	29	28	27	26	25	24	23	22	21	20	19	18	17	16
Reserved															
15	14	13	12	11	10	9	8	7	6	5	4	3	2	1	0
Reserved															

[31:0] Reserved

PCI Register 3c

Address PCI Base address + 0x3c

Type read only

31	30	29	28	27	26	25	24	23	22	21	20	19	18	17	16
Max_lat								min grant							
15	14	13	12	11	10	9	8	7	6	5	4	3	2	1	0
interrupt pin								interrupt line							

[31:24] max_lat- It specifies TW2809 PCI max_lat

Default value: 0x48

[23:16] min_gnt - It specifies TW2809 PCI min_gnt

Default value: 0x20

[15:8] interrupt pin - It specifies TW2809 PCI interrupt pin

Default value: 0x01

[7:0] interrupt line - It specifies TW2809 PCI interrupt line

Default value: 0x00

Pin Mux Register Definitions

This section describes TW2809 pin mux register definitions. These registers shall be directly programmed by external host during power up.

UART Pin Mux Configuration

Address 0x8000_1404

Type r/w

31	30	29	28	27	26	25	24	23	22	21	20	19	18	17	16
	dbg														
15	14	13	12	11	10	9	8	7	6	5	4	3	2	1	0

[31] reserved

[30] dbg – It specifies chip debug mode. To enable *uart*, this bit shall be set to LOW.

[29:0] reserved

Address 0x8000_1408

Type r/w

31	30	29	28	27	26	25	24	23	22	21	20	19	18	17	16
												uart1_en	uart0_en	mux_vo	
15	14	13	12	11	10	9	8	7	6	5	4	3	2	1	0

[31:20] reserved

[19] uart1_en – It specifies pin mux control. To make pin H18 and H19 to be *uart1*, this bit shall be set to HIGH.

[18] uart0_en – It specifies pin mux control. To make pin H20 and G17 to be *uart0*, this bit shall be set to HIGH.

[17] mux_vo – It specifies pin mux control. To enable *uart0/uart1*, this bit shall be set to LOW.

[16:0] reserved

DESCRIPTIONS

Pin H20 and G17 is muxed by video input port 3 data bus [1:0] and *uart0*. In order to make these two pins to be *uart0*. Pin H18 and H19 is muxed by video input port3 data bus[3:2]. In order to make these two pins to be *uart1*, both register 0x8000_1404 and 0x8000_1408 need to be programmed.

Ball Num	Symbol	Pin Mux	Mux condition
TW2809C UART1			
H18	vi3_data[3]	uart1_Tx	8000_1404[30] = 1'b0 8000_1408[17] = 1'b0 8000_1408[19] = 1'b1
H19	vi3_data[2]	uart1_Rx	8000_1408[19] = 1'b1
TW2809C UART0			
H20	vi3_data[1]	uart0_Tx	8000_1404[30] = 1'b0 8000_1408[17] = 1'b0 8000_1408[18] = 1'b1
G17	vi3_data[0]	uart0_Rx	8000_1408[18] = 1'b1

GPIO[7:0] Pin Mux Configuration

Address 0x8000_1404

Type r/w

31	30	29	28	27	26	25	24	23	22	21	20	19	18	17	16
	dbg														
15	14	13	12	11	10	9	8	7	6	5	4	3	2	1	0

[31] reserved

[30] dbg - It specifies chip debug mode. To enable *gpio[7:0]*, this bit shall be set to LOW.

[29:0] reserved

Address 0x8000_1408

Type r/w

31	30	29	28	27	26	25	24	23	22	21	20	19	18	17	16
											gpio_en				
15	14	13	12	11	10	9	8	7	6	5	4	3	2	1	0

[31:21] reserved

[20] gpio_en - It specifies pin mux control. To enable *gpio[7:0]*, this bit shall be set to HIGH.

[19:0] reserved

DESCRIPTIONS

GPIO[7:0] is muxed with video output port 2. In order to enable *gpio[7:0]*, both register 0x8000_1404 and 0x8000_1408 need to be programmed.

BALL NUM	SYMBOL	PIN MUX	MUX CONDITION
W4	vo2_data[7]	GPIO[7]	8000_1404[30] = 1'b0 8000_1408[20] = 1'b1 8000_1C40[7:0] controls GPIO direction Output: 1'b1 Input: 1'b0
Y3	vo2_data[6]	GPIO[6]	
Y4	vo2_data[5]	GPIO[5]	
Y5	vo2_data[4]	GPIO[4]	
W5	vo2_data[3]	GPIO[3]	
V5	vo2_data[2]	GPIO[2]	
U5	vo2_data[1]	GPIO[1]	
Y6	vo2_data[0]	GPIO[0]	

GPIO[15:8] Pin Mux Configuration

Address 0x8000_1400

Type r/w

31	30	29	28	27	26	25	24	23	22	21	20	19	18	17	16
mux_vi															
15	14	13	12	11	10	9	8	7	6	5	4	3	2	1	0

[31] mux_vi – It specifies vi/vo mux mode. To enable *gpio[15:8]* and *gpio[23:16]*, this bit shall be set to LOW.

[30:0] reserved

Address 0x8000_1408

Type r/w

31	30	29	28	27	26	25	24	23	22	21	20	19	18	17	16
gpio_en															
15	14	13	12	11	10	9	8	7	6	5	4	3	2	1	0

[31] gpio_en – It specifies pin mux control. To enable *gpio[15:8]*, this bit shall be set to HIGH.

[30:0] reserved

DESCRIPTIONS

GPIO[15:8] is muxed with video output port 1. In order to enable *gpio[15:8]*, both register 0x8000_1400 and 0x8000_1408 need to be programmed.

BALL NUM	SYMBOL	PIN MUX	TW2809B MUX CONDITION
D18	vo1_data[7]	GPIO[15]	8000_1400[31] = 1'b1 8000_1408[31] = 1'b1 8000_1C40[15:8] controls GPIO direction Output: 1'b1 Input: 1'b0
D19	vo1_data[6]	GPIO[14]	
D20	vo1_data[5]	GPIO[13]	
C18	vo1_data[4]	GPIO[12]	
C19	vo1_data[3]	GPIO[11]	
C20	vo1_data[2]	GPIO[10]	
B19	vo1_data[1]	GPIO[9]	
B20	vo1_data[0]	GPIO[8]	

GPIO[23:16] Pin Mux Configuration

Address 0x8000_1400

Type r/w

31	30	29	28	27	26	25	24	23	22	21	20	19	18	17	16
mux_vi															
15	14	13	12	11	10	9	8	7	6	5	4	3	2	1	0

[31] mux_vi – It specifies vi/vo mux mode. To enable *gpio[15:8]* and *gpio[23:16]*, this bit shall be set to LOW.

[30:0] reserved

Address 0x8000_1408

Type r/w

31	30	29	28	27	26	25	24	23	22	21	20	19	18	17	16
	gpio_en														
15	14	13	12	11	10	9	8	7	6	5	4	3	2	1	0

[31] reserved

[30] gpio_en – It specifies pin mux control. To enable *gpio[23:16]*, this bit shall be set to HIGH.

[29:0] reserved

DESCRIPTIONS

GPIO[23:16] is muxed with video output port 0. In order to enable *gpio[23:16]*, both register 0x8000_1400 and 0x8000_1408 need to be programmed.

BALL NUM	SYMBOL	PIN MUX	TW2809B MUX CONDITION
G19	vo0_data[7]	GPIO[23]	8000_1400[31] = 1'b1 8000_1408[30] = 1'b1 8000_1C40[23:16] controls GPIO direction Output: 1'b1 Input: 1'b0
F17	vo0_data[6]	GPIO[22]	
F18	vo0_data[5]	GPIO[21]	
F19	vo0_data[4]	GPIO[20]	
E18	vo0_data[3]	GPIO[19]	
E19	vo0_data[2]	GPIO[18]	
E20	vo0_data[1]	GPIO[17]	
D17	vo0_data[0]	GPIO[16]	

GPIO[31:24] Pin Mux Configuration

Address 0x8000_1404

Type r/w

31	30	29	28	27	26	25	24	23	22	21	20	19	18	17	16
	dbg														
15	14	13	12	11	10	9	8	7	6	5	4	3	2	1	0

[31] reserved

[30] dbg - It specifies chip debug mode. To enable *gpio[31:24]*, this bit shall be set to LOW.

[29:0] reserved

Address 0x8000_1408

Type r/w

31	30	29	28	27	26	25	24	23	22	21	20	19	18	17	16
												uart1_en	uart0_en	mux_vo	
15	14	13	12	11	10	9	8	7	6	5	4	3	2	1	0

[31:20] reserved

[19] uart1_en - It specifies pin mux control. To enable *gpio[31:24]*, this bit shall be set to LOW.[18] uart0_en - It specifies pin mux control. To enable *gpio[31:24]*, this bit shall be set to LOW..[17] mux_vo - It specifies pin mux control To enable *gpio[31:24]*, this bit shall be set to LOW.

[16:0] reserved

Descriptions

GPIO[31:24] is muxed with video input port 3. In order to enable *gpio[31:24]*, both register 0x8000_1404 and 0x8000_1408 need to be programmed.

BALL NUM	SYMBOL	PIN MUX	TW2809B MUX CONDITION
K20	vi3_data[7]	GPIO[31]	8000_1404[30] = 1'b0 8000_1408[19:17] = 3'b000 8000_1C40[31:24] controls GPIO direction Output: 1'b1 Input: 1'b0
J18	vi3_data[6]	GPIO[30]	
J19	vi3_data[5]	GPIO[29]	
H17	vi3_data[4]	GPIO[28]	
H18	vi3_data[3]	GPIO[27]	
H19	vi3_data[2]	GPIO[26]	
H20	vi3_data[1]	GPIO[25]	
G17	vi3_data[0]	GPIO[24]	

GPIO[39:32] pin mux configuration

Address 0x8000_1404

Type r/w

31	30	29	28	27	26	25	24	23	22	21	20	19	18	17	16
	dbg														
15	14	13	12	11	10	9	8	7	6	5	4	3	2	1	0

[31] reserved

[30] dbg - It specifies chip debug mode. To enable *gpio[39:32]*, this bit shall be set to LOW.

[29:0] reserved

Address 0x8000_1408

Type r/w

31	30	29	28	27	26	25	24	23	22	21	20	19	18	17	16
															mux_vo
15	14	13	12	11	10	9	8	7	6	5	4	3	2	1	0

[31:17] reserved

[16] mux_vo - It specifies pin mux control To enable *gpio[39:32]*, this bit shall be set to LOW.

[15:0] reserved

DESCRIPTIONS

GPIO[39:32] is muxed with video input port 2. In order to enable *gpio[39:32]*, both register 0x8000_1404 and 0x8000_1408 need to be programmed.

BALL NUM	SYMBOL	PIN MUX	TW2809B MUX CONDITION
M18	vi2_data[7]	GPIO[39]	8000_1404[30] = 1'b0 8000_1408[16] = 1'b0 8000_1C44[7:0] controls GPIO direction Output: 1'b1 Input: 1'b0
M19	vi2_data[6]	GPIO[38]	
L17	vi2_data[5]	GPIO[37]	
L18	vi2_data[4]	GPIO[36]	
L19	vi2_data[3]	GPIO[35]	
K17	vi2_data[2]	GPIO[34]	
K18	vi2_data[1]	GPIO[33]	
K19	vi2_data[0]	GPIO[32]	

GPIO[47:40] Pin Mux Configuration

Address 0x8000_1404

Type r/w

31	30	29	28	27	26	25	24	23	22	21	20	19	18	17	16
	dbg														
15	14	13	12	11	10	9	8	7	6	5	4	3	2	1	0

[31] reserved

[30] dbg - It specifies chip debug mode. To enable *gpio[47:40]*, this bit shall be set to LOW.

[29:0] reserved

DESCRIPTIONS

GPIO[47:40] is muxed with video input port 1. In order to enable *gpio[47:40]*, register 0x8000_1404 needs to be programmed.

BALL NUM	SYMBOL	PIN MUX	TW2809B MUX CONDITION
R19	vi1_data[7]	GPIO[47]	8000_1404[30] = 1'b0 8000_1C44[15:8] controls GPIO direction Output: 1'b1 Input: 1'b0
P17	vi1_data[6]	GPIO[46]	
P18	vi1_data[5]	GPIO[45]	
P19	vi1_data[4]	GPIO[44]	
N18	vi1_data[3]	GPIO[43]	
N19	vi1_data[2]	GPIO[42]	
N20	vi1_data[1]	GPIO[41]	
M17	vi1_data[0]	GPIO[40]	

GPIO[55:48] pin mux configuration

Address 0x8000_1408

Type r/w

31	30	29	28	27	26	25	24	23	22	21	20	19	18	17	16
								spi_e	uart1_e	gpio_e					
15	14	13	12	11	10	9	8	7	6	5	4	3	2	1	0

[31:24] reserved

[23] spi_e – It specifies spi enable. To enable *gpio[55:48]*, this bit shall be set to LOW.[22] uart1_e – It specifies uart1 enable. To enable *gpio[55:48]*, this bit shall be set to LOW.[21] gpio_e – It specifies gpio enable. To enable *gpio[55:48]*, this bit shall be set to HIGH.

[20:0] reserved

DESCRIPTIONS

GPIO[55:48] is muxed with video output port 3. In order to enable *gpio[55:48]*, register 0x8000_1408 needs to be programmed.

BALL NUM	SYMBOL	PIN MUX	TW2809B MUX CONDITION
U9	vo3_data[7]	GPIO[55]	8000_1408[23:21] = 3'b001 8000_1C44[23:16] controls GPIO direction Output: 1'b1 Input: 1'b0
V8	vo3_data[6]	GPIO[54]	
U18	vo3_data[5]	GPIO[53]	
V18	vo3_data[4]	GPIO[52]	
U17	vo3_data[3]	GPIO[51]	
V19	vo3_data[2]	GPIO[50]	
W19	vo3_data[1]	GPIO[49]	
W20	vo3_data[0]	GPIO[48]	

PDMA Register Definitions

This section describes PDMA control module registers. PDMA has three kind of operation and is explained separately in this chapter.

Master Mode

PDMA INTERRUPT STATUS REGISTER FOR FW

Address HIF base address + 0x48

Type r/w

31	30	29	28	27	26	25	24
DEBUG_EN						SMBUS_ERR_INT_ST	MMBUS_ERR_INT_ST
23	22	21	20	19	18	17	16
	SLV_INT_ST	PERR_INT_ST	FATAL_INT_ST	RX_INT_ST	TX_INT_ST	CFG_INT_ST	COM_INT_ST
15	14	13	12	11	10	9	8
						SMBUS_ERR_INT_EN	MMBUS_ERR_INT_EN
7	6	5	4	3	2	1	0
	SLV_INT_EN	PERR_INT_EN	FATAL_INT_EN	M_RX_INT_EN	M_TX_INT_EN	CFG_INT_EN	COM_INT_EN

[31] DEBUG_EN – It specifies the debugging enable

[30:26] reserved

[25] SMBUS_ERR_INT_ST – It specifies the error of mbus for slave mode

[24] MMBUS_ERR_INT_ST – It specifies the error of mbus for master mode

[23] reserved

[22] SLV_INT_ST – It specifies the information of slave interrupt

[21] PERR_INT_ST – It specifies the information of PCI parity error interrupt.

[20] FATAL_INT_ST – It specifies the information of PCI fatal error interrupt.

[19] RX_INT_ST – It specifies the information of end of RX transfer interrupt.

[18] TX_INT_ST – It specifies the information of end of TX transfer interrupt.

[17] CFG_INT_ST – It specifies the information of configuration interrupt.

[16] COM_INT_ST – It specifies the information of communication interrupt.

[15:10] reserved

[09] SMBUS_ERR_INT_EN – It specifies the mbus error interrupt enable for slave mode

[08] MMBUS_ERR_INT_EN – It specifies the mbus error interrupt enable for master mode

[07] reserved

[06] SLV_INT_EN – It specifies the slave interrupt enable.

[05] PERR_INT_EN – It specifies parity error interrupt enable.

[04] FATAL_INT_EN – It specifies fatal error interrupt enable.

[03] M_RX_INT_EN – It specifies the end of RX transfer interrupt enable.

[02] M_TX_INT_EN – It specifies the end of TX transfer interrupt enable.

[01] CFG_INT_EN – It specifies the configuration interrupt enable.

[00] COM_INT_EN – It specifies the command interrupt enable.

DESCRIPTIONS

PDMA supports to manage the interrupt sperately between FW and host driver. So the interrupt register is only used by FW, not the host driver. Even if these interrupts are enabled and the host driver interrupts, which address "0x4c" are disable in the same bit, PCI interrupt doesn't generate to host driver, but it is sent to FW.

For example, FW enables TX transfer. Then, it means the end of TX transfer interrupt to be sent into FW, not host driver.

In initial time, FW should enable PCI interrupt enable bits. If PCI interrupt enable bits are disabled, all of interrupt except COM_INT_EN don't generate the interrupt. Otherwise, PDMA can keep the interrupt when PDMA generates the interrupt during COM_IN_EN to be disabled. Then PDMA will send the interrupt after COM_IN_EN to be enabled.

PDMA MASTER TX AND RX INTERRUPT STATUS REGISTER (OPTIONAL)

Address HIF base address + 0x60

Type r

31	30	29	28	27	26	25	24	23	22	21	20	19	18	17	16
15	14	13	12	11	10	9	8	7	6	5	4	3	2	1	0
														RX END	TX END

[31:02] reserved

[01] RX_END – It specifies end of RX transfer.

[00] TX_END – It specifies end of TX transfer

DESCRIPTIONS

This register isn't used the normal operation. But sometimes FW or host driver doesn't receive PDMA interrupt after finishing the reading and writing data. In that time, FW or host driver could just check the end of transfer using polling.

PDMA MASTER TX AND RX ENDIAN CONTROL REGISTER

Address HIF Base address + 0x58

Type r/w

31	30	29	28	27	26	25	24	23	22	21	20	19	18	17	16
15	14	13	12	11	10	9	8	7	6	5	4	3	2	1	0
M_R_ENDIAN [02:00]				M_W_ENDIAN [02:00]				S_R_ENDIAN [02:00]				S_W_ENDIAN [02:00]			

[31:15] reserved

[14:12] M_R_ENDIAN - It specifies the endian control of read data for master mode.

[11] reserved

[10:08] M_W_ENDIAN - It specifies the endian control of write data for master mode.

[07] reserved

[06:04] S_R_ENDIAN - It specifies the endian control of read data for slave mode.

[03] reserved

[02:00] S_W_ENDIAN - It specifies the endian control of write data for slave mode.

DESCRIPTIONS

Intel processor uses "little endian", but TW2809 uses "big endian". In the case host driver wants to change little endian to big endian or big endian to little endian. So our PDMA is able to support it.

The following table bases on the 8 byte which our bus width is.

M_ENDIAN OR S_ENDIAN	DATA FORMAT
0	Data[63:00]
1	Data[39:32],Data[47:40],Data[55:48],Data[63:56],Data[07:00],Data[15:08],Data[23:16],Data[31:24]
2	Data[47:40],Data[39:32],Data[63:56],Data[55:48],Data[15:08],Data[07:00],Data[31:24],Data[23:16]
3	Data[31:24],Data[23:16],Data[15:08],Data[07:00],Data[63:56],Data[55:48],Data[47:40],Data[39:32]
4	Data[55:48],Data[63:56],Data[39:32],Data[47:40],Data[23:16],Data[31:24],Data[07:00],Data[15:08]
5	Data[07:00],Data[15:08],Data[23:16],Data[31:24],Data[39:32],Data[47:40],Data[55:48],Data[63:56]
6	Data[15:08],Data[07:00],Data[31:24],Data[23:16],Data[47:40],Data[39:32],Data[63:56],Data[55:48]
7	Data[23:16],Data[31:24],Data[07:00],Data[15:08],Data[55:48],Data[63:56],Data[39:32],Data[47:40]

PDMA MASTER TX CONTROL REGISTER

Address HIF Base address + 0x64

Type r/w

31	30	29	28	27	26	25	24	23	22	21	20	19	18	17	16
													M_TX 2D_FORMAT[02:00]		M_TX 2D_EN
15	14	13	12	11	10	9	8	7	6	5	4	3	2	1	0
															M_TX START

[31:19] reserved

[18:17] M_TX_2D_FORMAT - It specifies the data format while TX 2D access.

[16] M_TX_2D_EN - It specifies TX 2D access enable.

[15:01] reserved

[00] M_TX_START - It specifies PCI DMA TX start request for master mode.

DESCRIPTIONS

Host driver or FW should enable "M_TX_START" bit after writing PDMA parameter registers such as TX start address, total length and TX buffer ID. Also "M_TX_START" bit is disabled automatically when TX transfer is finished.

However, TX transfer means FW transfers some data into PCI host or host driver reads some data from our external memory.

PDMA MASTER TX BUFFER ID REGISTER

Address HIF base address + 0x68

Type r/w

31	30	29	28	27	26	25	24	23	22	21	20	19	18	17	16
M_TX_FRAME_ID[31:16]															
15	14	13	12	11	10	9	8	7	6	5	4	3	2	1	0
M_TX_FRAME_ID[15:00]															

[31:00] M_TX_FRAME_ID - It specifies the buffer ID which FW defines in our frame memory.

DESCRIPTIONS

The "M_TX_BUF_ID", which is indicated a position in our external memory, is decided by FW at initial time, not host driver. If host driver wants to know a value of this register, host driver should get the value from FW using communication protocol.

PDMA MASTER TX TARGET START ADDRESS REGISTER

Address HIF base address + 0x6C

Type r/w

31	30	29	28	27	26	25	24	23	22	21	20	19	18	17	16
M_TX_TAR_ADDR[31:16]															
15	14	13	12	11	10	9	8	7	6	5	4	3	2	1	0
M_TX_TAR_ADDR[15:00]															

[31:00] M_X_TAR_ADDR – It specifies the target address which is in host driver.

DESCRIPTIONS

When FW transfers some data or host driver receives data, FW should know the target address which is the internal buffer in host driver. FW can know the target address using the communication protocol with host driver.

PDMA MASTER TX TOTAL LENGTH REGISTER

Address HIF base address + 0x70

Type r/w

31	30	29	28	27	26	25	24	23	22	21	20	19	18	17	16
M_TX_TOTAL_LENGTH[31:16]															
15	14	13	12	11	10	9	8	7	6	5	4	3	2	1	0
M_TX_TOTAL_LENGTH[15:00]															

[31:00] M_TX_TOTAL_LENGTH – It species the TX total length.

PDMA MASTER TX 2D XY START REGISTER

Address HIF base address + 0xA4

Type r/w

31	30	29	28	27	26	25	24	23	22	21	20	19	18	17	16
								M_TX_2D_X_START[07:00]							
15	14	13	12	11	10	9	8	7	6	5	4	3	2	1	0
								M_TX_2D_Y_START[10:00]							

[31:24] reserved

[23:16] M_TX_2D_X_START– It speifies the start of X coordinate for TX 2D transfer

[15:11] reserved

[10:00] M_TX_2D_Y_START– It speifies the start of Y coordinate for TX 2D transfer

PDMA MASTER RX CONTROL REGISTER

Address HIF Base address + 0x78

Type r/w

31	30	29	28	27	26	25	24	23	22	21	20	19	18	17	16
													M_RX_2D FORMAT[02:00]		M_RX 2D_EN
15	14	13	12	11	10	9	8	7	6	5	4	3	2	1	0
															M_RX START

[31:19] reserved

[18:17] M_RX_2D_FORMAT – It specifies the data format for RX 2D transfer

[16] M_RX_2D_EN – It specifies RX 2D transfer enable.

[15:01] reserved

[00] M_RX_START – It specifies RX DMA start request.

DESCRIPTIONS

Host driver or FW can enable the bit, “M_RX_START”, after setting PDMA RX parameter registers such as TX start address and total length. Also “M_RX_START” bit is disabled automatically by PDMA when TX transfer is finished.

However, RX transfer means host driver writes some data into our external memory.

PDMA MASTER RX BUFFER ID REGISTER

Address HIF base address + 0x7C

Type r/w

31	30	29	28	27	26	25	24	23	22	21	20	19	18	17	16
M_RX_FRAME_ID[31:16]															
15	14	13	12	11	10	9	8	7	6	5	4	3	2	1	0
M_RX_FRAME_ID[15:00]															

[31:00] M_RX_FRAME_ID – It specifies the RX FRAME ID which FW defines in our frame memory.

DESCRIPTIONS

The “M_RX_BUF_ID”, which is indicated a buffer in our external memory, is decided by FW, not host driver at initial time. If host driver wants to know the value of “M_RX_BUF_ID”, host driver should get the value from FW using commulation protocol.

PDMA MASTER RX SOURCE START ADDRESS REGISTER

Address HIF base address + 0x80

Type r/w

31	30	29	28	27	26	25	24	23	22	21	20	19	18	17	16
M_RX_S_ADDR[31:16]															
15	14	13	12	11	10	9	8	7	6	5	4	3	2	1	0
M_RX_S_ADDR[15:00]															

[31:00] M_RX_S_ADDR - It specifies the source address which is the start address of internal buffer in host driver.

DESCRIPTIONS

If host driver wants to send some data into our buffer or FW wants to read some data from host driver's buffer, FW or host driver set up "M_RX_S_ADDR" which is in host driver's start buffer address. So FW should gets the information from host driver using communication register.

PDMA MASTER RX TOTAL LENGTH REGISTER

Address HIF base address + 0x84

Type r/w

31	30	29	28	27	26	25	24	23	22	21	20	19	18	17	16
M_RX_TOTAL_LENGTH[31:16]															
15	14	13	12	11	10	9	8	7	6	5	4	3	2	1	0
M_RX_TOTAL_LENGTH[15:00]															

[31:00] M_RX_TOTAL_LENGTH - It species the RX total length.

PDMA MASTER RX 2D XY START REGISTER

Address HIF base address + 0xA8

Type r/w

31	30	29	28	27	26	25	24	23	22	21	20	19	18	17	16
								M_RX_2D_X_START[07:00]							
15	14	13	12	11	10	9	8	7	6	5	4	3	2	1	0
								M_RX_2D_Y_START[10:00]							

[31:24] reserved

[23:16] M_2D_RX_X_START- It specifies the start of X coordinate for RX 2D transfer

[10:00] M_2D_RX_Y_START- It specifies the start of Y coordinate for RX 2D transfer

Slave Mode

HOST PCI driver should control registers for reading and writing.

PDMA SLAVE TX CONTROL REGISTER

Address HIF Base address + 0x24

Type r/w

31	30	29	28	27	26	25	24	23	22	21	20	19	18	17	16
													S_TX_2D FORMAT[01:00]		S_TX 2D_EN
15	14	13	12	11	10	9	8	7	6	5	4	3	2	1	0
											S_TX_ STRN				S_TX START

[31:19] reserved

[18:17] S_TX_2D_FORMAT - It specifies the data format while TX 2D access

[16] S_TX_2D_EN - It specifies TX 2D access enable

[15:05] reserved

[04] S_TX_STRN - It specifies the single transfer enable

[03:01] reserved

[00] S_TX_START - It specifies DMA start request

DESCRIPTIONS

Currently, our host driver only supports the single transfer, not burst transfer for slave mode.

If host driver uses the single transfer, PCI should enable "S_TX_STRN" bit.

Host driver or FW enables "S_TX_START" bit after finishing to write other TX setting registers such as TX start address and length.

In addition, the performance is so slowly. Because PCI host driver is waiting to write data until receiving PCI interrupt after each 128 word transfer. This means PDMA internal buffer to be limited, 128 word.

PDMA SLAVE TX BUFFER ID REGISTER

Address HIF base address + 0x28

Type r/w

31	30	29	28	27	26	25	24	23	22	21	20	19	18	17	16
15	14	13	12	11	10	9	8	7	6	5	4	3	2	1	0
										S_TX_BUF_ID[05:00]					

[31:06] reserved

[05:00] S_TX_BUF_ID - It specifies TX buffer ID

DESCRIPTIONS

The S_TX_BUF_ID, which is indicated a buffer ID in our external memory, is decided by FW, not PCI host driver. So PCI host driver should get the buffer ID from FW using commulation protocol.

PDMA SLAVE TX TOTAL LENGTH REGISTER

Address HIF base address + 0x2c

Type r/w

31	30	29	28	27	26	25	24	23	22	21	20	19	18	17	16
S_TX_TOTAL_LENGTH[31:16]															
15	14	13	12	11	10	9	8	7	6	5	4	3	2	1	0
S_TX_TOTAL_LENGTH[15:00]															

[31:00] S_TX_TOTAL_LENGTH - It specifies the TX total length

DESCRIPTIONS

When PCI driver transfers some data into our external memory, PCI driver writes the total length, which is word count, into the register.

PDMA SLAVE TX 2D XY START REGISTER

Address HIF base address + 0xAC

Type r/w

31	30	29	28	27	26	25	24	23	22	21	20	19	18	17	16
								S_TX_2D_X_START[07:00]							
15	14	13	12	11	10	9	8	7	6	5	4	3	2	1	0
								S_TX_2D_Y_START[10:00]							

[31:24] reserved

[23:16] S_TX_2D_X_START- It specifies the start of X for TX 2D accessing for slave mode

[15:11] reserved

[10:00] S_TX_2D_Y_START- It specifies the start of Y for TX 2D accessing for slave mode

PDMA SLAVE RX CONTROL REGISTER

Address HIF Base address + 0x34

Type r/w

31	30	29	28	27	26	25	24	23	22	21	20	19	18	17	16
												S_RX_2D FORAMT[01:00]		S_RX_2D _EN	
15	14	13	12	11	10	9	8	7	6	5	4	3	2	1	0
														S_RX START	

[31:19] reserved

[18:17] S_RX_2D_FORMAT - It specifies the data format while RX 2D access

[16] S_RX_2D_EN- It specifies RX 2D access enable

[15:01] reserved

[00:00] S_RX_START - It specifies the starting of RX DMA

DESCRIPTIONS

PCI host driver or FW enables "S_RX_START" bit after finishing to write other RX setting registers such as RX start address and length.

If PCI host driver write some data using 2D access, PCI host driver decides the written format. The information is decided by FW.

PDMA SLAVE RX BUFFER ID REGISTER

Address HIF base address + 0x38

Type r/w

31	30	29	28	27	26	25	24	23	22	21	20	19	18	17	16
[31:06] reserved															
15	14	13	12	11	10	9	8	7	6	5	4	3	2	1	0
										S_R_BUF_ID[05:00]					

[31:06] reserved

[05:00] S_R_BUF_ID - It specifies the external RX buffer ID

DESCRIPTIONS

The "S_R_BUF_ID", which is one of buffer ID in our external memory, is decided by FW, not PCI host driver. So PCI host driver should get the "S_R_BUF_ID" from FW using cumulation protocol.

PDMA SLAVE RX TOTAL LENGTH REGISTER

Address HIF base address + 0x3c

Type r/w

31	30	29	28	27	26	25	24	23	22	21	20	19	18	17	16
S_RX_TOTAL_LENGTH[31:16]															
15	14	13	12	11	10	9	8	7	6	5	4	3	2	1	0
S_RX_TOTAL_LENGTH[15:00]															

[31:00] S_RX_TOTAL_LENGTH - It specifies the RX total length

DESCRIPTIONS

When PCI driver transfers some data into our external memory or FW receives some data from internal buffer of PCI host driver, PCI driver writes the total length, which is word count, into the register.

PDMA SLAVE RX 2D XY START REGISTER

Address HIF base address + 0x88

Type r/w

31	30	29	28	27	26	25	24	23	22	21	20	19	18	17	16
								S_RX_2D_X_START[07:00]							
15	14	13	12	11	10	9	8	7	6	5	4	3	2	1	0
								S_RX_2D_Y_START[10:00]							

[31:24] reserved

[23:16] S_RX_2D_X_START- It specifies the start of X for RX 2D accessing for slave mode

[15:11] reserved

[10:00] S_RX_2D_Y_START- It specifies the start of Y for RX 2D accessing for slave mode

PDMA SLAVE INTERRUPT STATUS REGISTER

Address HIF base address + 0x44

Type r

31	30	29	28	27	26	25	24	23	22	21	20	19	18	17	16
15	14	13	12	11	10	9	8	7	6	5	4	3	2	1	0
												RX_ END	RX_ EMT	TX_ END	TX_ FULL

[31:04] reserved

[03] RX_END – It specifies the end of RX transfer

[02] RX_EMT– It specifies the empty of RX fifo

[01] TX_END – It specifies the end of TX transfer

[00] TX_FULL – It specifies the full of TX fifo

DESCRIPTIONS

Host driver or FW has to check PCI interrupt status register when host driver or FW receives PCI interrupt. If “SLV_ST” bit in PCI interrupt status is asserted, host driver or FW should check data in this register. Then PCI host or FW can know what kind of the interrupt for slave mode.

Communication Between FW and Host

These registers are used to communicate between FW and host driver.

In the further, FW and Host driver will be decided some commands for proper processing.

THE COMMUNICATION COMMAND REGISTER FROM HOST DRIVER

Address HIF base address + 0x8C

Type r/w

31	30	29	28	27	26	25	24	23	22	21	20	19	18	17	16
CMD_FROM_HOST[31:16]															
15	14	13	12	11	10	9	8	7	6	5	4	3	2	1	0
CMD_FROM_HOST[15:00]															

[31:00] CMD_FROM_HOST- It specifies a communication command which host driver sends into FW.

DESCRIPTIONS

PDMA generates the interrupt to FW when host driver writes a command in this register. FW will operate the proper task after reading data in the PCI interrupt service routine of FW.

For example, host driver sends a command which is ready the decoding bitstream after sending the decoding bitstream into a external VLD buffer of TW2809. In that time, host driver uses this register.

THE FIRST EXTRA COMMUNICATION REGISTER FROM HOST DRIVER

Address HIF base address + 0x54

Type r/w

31	30	29	28	27	26	25	24	23	22	21	20	19	18	17	16
CMD_EXTRA1_FROM_HOST[31:16]															
15	14	13	12	11	10	9	8	7	6	5	4	3	2	1	0
CMD_EXTRA1_FROM_HOST[15:00]															

[31:00] CMD_EXTRA1_FROM_HOST - It specifies the first extra communication data

DESCRIPTIONS

Sometimes, host driver needs to have the first extra data with a command. In that time, host driver uses the register. Host driver has to write the register before writing the communication register, "Communication Register from Host".

For example, host driver wants to send the command, which is the bitstream size, after sending the bitstream for decoding. In that time, host driver writes the bitstream size into this register. Then FW can know the bitstream size after reading this register.

THE SECOND EXTRA COMMUNICATION REGISTER FROM HOST DRIVER

Address HIF base address + 0x58

Type r/w

31	30	29	28	27	26	25	24	23	22	21	20	19	18	17	16
CMD_EXTRA2_FROM_HOST[31:16]															
15	14	13	12	11	10	9	8	7	6	5	4	3	2	1	0
CMD_EXTRA2_FROM_HOST[15:00]															

[31:00] CMD_EXTRA2_FROM_HOST - It specifies the second extra communication data

THE COMMUNICATION COMMAND REGISTER FROM FW

Address HIF base address + 0x90

Type r/w

31	30	29	28	27	26	25	24	23	22	21	20	19	18	17	16
CMD_FROM_FW[31:16]															
15	14	13	12	11	10	9	8	7	6	5	4	3	2	1	0
CMD_FROM_FW[15:00]															

[31:00] CMD_FROM_FW - It specifies a communication command which FW sends into host.

DESCRIPTIONS

PDMA's able to generate the the interrupt to host driver when FW writes this register. After that, host driver will operate the proper task after reading the command.

For example, FW wants to receive a bitstream of slice for decoding. In that time, FW writes a command into the register. And host driver receives the command. Then, host driver will download the bitstream into external VLD buffer of TW2809. In the futher, FW and host driver will define the value of command.

THE FIRST EXTRA COMMUNICATION REGISTER FROM FW

Address HIF base address + 0x94

Type r/w

31	30	29	28	27	26	25	24	23	22	21	20	19	18	17	16
EXTRA1_COM_FROM_FW[31:16]															
15	14	13	12	11	10	9	8	7	6	5	4	3	2	1	0
EXTRA1_COM_FROM_FW[15:00]															

[31:00] EXTRA1_COM_FROM_FW – It specifies the first extra communication data.

DESCRIPTIONS

Sometimes, FW needs to have extra data with a command. In that time, FW uses current register. FW has to write the register before writing the communication register, “Communication Register from FW”.

For example, FW sends the command, which is the request bitstream, to host driver. In that time, FW also send a buffer ID which is defined the external VLD buffer. Then FW writes the buffer ID into the register. Therefore host driver can know buffer ID after reading this register.

THE SECOND EXTRA COMMUNICATION REGISTER FROM FW

Address HIF base address + 0x98

Type r/w

31	30	29	28	27	26	25	24	23	22	21	20	19	18	17	16
EXTRA2_COM_FROM_FW[31:16]															
15	14	13	12	11	10	9	8	7	6	5	4	3	2	1	0
EXTRA2_COM_FROM_FW[15:00]															

[31:00] EXTRA2_COM_FROM_FW – It specifies the second extra communication data

DESCRIPTIONS

Sometimes, FW needs to have extra data with a communication command. In that time, FW uses the register. FW has to write the register before writing the communication register, “Communication Command Register from FW”.

For example, FW wants to send the command, which is the end of encoding, to host driver. In that time, FW also send the buffer ID which is defined in external VLC buffer, and a total length which is the bitstream size of current slice. Then FW uses extra #1 and #2 register. FW write the buffer ID into the register, “The First Communication Extra Register from FW”. Also current register is written the total length.

Interrupt Status for PCI Host Driver

PCI Host should read this registers when it receives PCI interrupt from TW2809.

PDMA INTERRUPT STATUS REGISTER FOR PCI CHANNEL

Address HIF base address + 0x4C

Type r/w

31	30	29	28	27	26	25	24
INT_EDGE_EN						SMBUS_ERR_INT_ST	MMBUS_ERR_INT_ST
23	22	21	20	19	18	17	16
WDOG_INT_ST	SLV_INT_ST	PERR_INT_ST	FATAL_INT_ST	RX_INT_ST	TX_INT_ST	CFG_INT_ST	COM_INT_ST
15	14	13	12	11	10	9	8
						SMBUS_ERR_INT_EN	MMBUS_ERR_INT_EN
7	6	5	4	3	2	1	0
WDOG_INT_EN	SLV_INT_EN	PERR_INT_EN	FATAL_INT_EN	RX_INT_EN	TX_INT_EN	CFG_INT_EN	COM_INT_EN

[31] INT_EDGE_EN - It specifies the edge trigger interrupt.

[30:26] reserved

[25] SMBUS_ERR_INT_ST - It specifies the error of mbus for slave mode

[24] MMBUS_ERR_INT_ST - It specifies the error of mbus for master mode

[23] WDOG_INT_ST - It specifies the information of watch dog.

[22] SLV_INT_ST - It specifies the interrupt for slave mode (debug mode)

[21] PERR_INT_ST - It specifies the information of parity error interrupt.

[20] FATAL_INT_ST - It specifies the information of fatal error interrupt.

[19] RX_INT_ST - It specifies the information of end of RX transfer.

[18] TX_INT_ST - It specifies the information of end of TX transfer.

[17] CFG_INT_ST - It specifies the information of config interrupt.

[16] COM_INT_ST - It specifies the information of command interrupt.

[15:10] reserved

[09] SMBUS_ERR_INT_EN - It specifies the mbus error interrupt enable for slave mode

[08] MMBUS_ERR_INT_EN - It specifies the mbus error interrupt enable for master mode

[07] WDOG_INT_EN - It specifies watch dog interrupt enable.

[06] SLV_INT_EN - It specifies slave mode interrupt enable.

[05] PERR_INT_EN - It specifies PCI parity error interrupt enable.

[04] FATAL_INT_EN - It specifies PCI fatal error interrupt enable.

[03] RX_INT_EN - It specifies RX END interrupt enable.

[02] TX_INT_EN - It specifies TX END interrupt enable.

[01] CFG_INT_EN - It specifies Configuration interrupt enable.

[00] COM_INT_EN - It specifies Command interrupt enable.

DESCRIPTIONS

Our PCI Interrupt supports the level trigger or edge trigger. Default is the level trigger interrupt. So if host driver wants to change the edge trigger, host driver enables "INT_EDGE_EN" bit.

Global Control Register Definitions

This section describes CTR module registers.

Normal Interrupt

Address CTR base address + 0x00

Type r/w

31	30	29	28	27	26	25	24	23	22	21	20	19	18	17	16
	jpeg	gpio	uart1	uart0	i2c	dsm	pci	aud	tme	tsmd	tsme	vlc	vld	egf	hpm
15	14	13	12	11	10	9	8	7	6	5	4	3	2	1	0
	jen	gpen	urt1en	urt0en	i2cen	dsmen	pcien	auden	tmeen	tsmde	tsmeen	vlcen	vlden	egfen	hpmen

[31] reserved

[30] jpeg – It specifies the normal interrupt from jpeg module

[29] gpio – It specifies the normal interrupt from gpio module

[28] uart1 – It specifies the normal interrupt from uart1 module

[27] uart0 – It specifies the normal interrupt from uart0 module

[26] i2c – It specifies the normal interrupt from i2c module

[25] dsm – It specifies the normal interrupt from dsm module

[24] pci – It specifies the normal interrupt from pci module

[23] aud – It specifies the normal interrupt from aud module

[22] tme – It specifies the normal interrupt from tme module

[21] tsmd – It specifies the normal interrupt from tsm decode module

[20] tsme – It specifies the normal interrupt from tsm encode module

[19] vlc – It specifies the normal interrupt from vlc module

[18] vld – It specifies the normal interrupt from vld module

[17] egf – It specifies the normal interrupt from egf module

[16] hpm – It specifies the normal interrupt from hpm module

[15] reserved

[14:0] enables – It specifies the normal interrupt enable for each corresponding module {30:16}

DESCRIPTIONS

DCM shall follow the interrupt protocol described in interrupt scheme section.

Codec Video Channel

Address CTR base address + 0x04

Type r/w

31	30	29	28	27	26	25	24	23	22	21	20	19	18	17	16
											cur_dec_ch				
15	14	13	12	11	10	9	8	7	6	5	4	3	2	1	0
											cur_enc_ch				

[31:21] reserved

[20:16] cur_dec_ch – It specifies current decode video channel

[15:5] reserved

[4:0] cur_enc_ch – It specifies current encode video channel

DESCRIPTIONS

DCM shall follow the interrupt protocol described in interrupt scheme section.

Software Reset

Address CTR base address + 0x08

Type r/w

31	30	29	28	27	26	25	24	23	22	21	20	19	18	17	16
					AUDD	DINT	uart1	uart0	i2c	IT	VLD	HPM	TME	MBC	VLC
15	14	13	12	11	10	9	8	7	6	5	4	3	2	1	0
JPG	EGF	SPR	TSM	RTB	IPD	DEC	ENC	AUD	DSM	VOF	VIF	PCI	HIF	DDR	MPU

[31:27] reserved

- [26] AUDD - Reset the audio decoding block
- [25] DINT - Reset the De-interlace block
- [24] UART1 - Reset the UART1 block
- [23] UART0 - Reset the UART0 block
- [22] I2C - Reset the I2C block
- [21] IT - Reset the IT block for decoding
- [20] VLD - Reset the VLD block for decoding
- [19] HPM - Reset the HPM block for decoding
- [18] TME - Reset the TME block for encoding
- [17] MBC - Reset the MBC block for encoding
- [16] VLC - Reset the VLC block for encoding
- [15] JPG - Reset JPEG
- [14] EGF - Reset the EGF block for encoding or decoding
- [13] SPR - Reset the SPR block for encoding or decoding
- [12] TSM - Reset the TSM block for encoding or decoding
- [11] RTB - Reset the RTB block for encoding or decoding
- [10] IPD - Reset the IPD block for encoding or decoding
- [09] DEC - Reset the all of decoder block
- [08] ENC - Reset the all of encoder block
- [07] AUD - Reset the audio encoding block
- [06] DSM - Reset the sub sample block
- [05] VOF - Reset the VOF block
- [04] VIF : Reset the VIF block
- [03] PCI : Reset the PCI block
- [02] HIF : Reset the HIF block
- [01] DDR : Reset the DDR controller
- [00] MPU : Reset the ARM and AMBA

DESCRIPTION

This register is used to control the TW2809 reset. Host or FW write LOW to assert tw2809 blocks reset. Host or FW write HIGH to release the reset.

If you want to assert reset to all of encoder block, you write LOW into “ENC” bit.

Then, all of encoder blocks will be asserted the reset. also you write LOW into “DEC” bit, all of decoder blocks will be asserted the reset.

Timer Period Register

Address CTR base address + 0x0C

Type r/w

31	30	29	28	27	26	25	24	23	22	21	20	19	18	17	16
timer3_period								timer2_period							
15	14	13	12	11	10	9	8	7	6	5	4	3	2	1	0
timer1_period								timer0_period							

[31:24] timer3_period – It specifies timer 3 period.

[23:16] timer2_period – It specifies timer 2 period.

[15:8] timer1_period – It specifies timer 1 period.

[7:0] timer0_period – It specifies timer 0 period.

DESCRIPTIONS

The timer period specifies the timer unit in terms of system cycle. If timer_period equals 0, then timer counter increments every cycle. If timer_period equals 1, then timer counter increments every 2 cycles.

Encode Mode Register

Address CTR base address + 0x10

Type r/w

31	30	29	28	27	26	25	24	23	22	21	20	19	18	17	16
15	14	13	12	11	10	9	8	7	6	5	4	3	2	1	0
enc_mode															

[31:1] Reserved

[0] enc_mode – It specifies the operation mode for the video pipeline.

Fast Interrupt

Address CTR base address + 0x14

Type r/w

31	30	29	28	27	26	25	24	23	22	21	20	19	18	17	16
timer0	timer1	timer2	timer3											vout	vin
15	14	13	12	11	10	9	8	7	6	5	4	3	2	1	0
t0en	t1en	t2en	t3en											voen	vien

[31] timer0 – It specifies the fast interrupt from timer0

[30] timer1 – It specifies the fast interrupt from timer1

[29] timer2 – It specifies the fast interrupt from timer2

[28] timer3 – It specifies the fast interrupt from timer 3

[27:18] reserved

[17] vout – It specifies the fast interrupt from VOUT module

[16] vin – It specifies the fast interrupt from VIN module

[12:2] reserved – It specifies the fast interrupt source.

[15] t0en – It specifies the fast interrupt enable for timer0

[14] t1en – It specifies the fast interrupt enable for timer1

[13] t2en – It specifies the fast interrupt enable for timer2

[12] t3en – It specifies the fast interrupt enable for timer3

[11:2] reserved

[1] voen – It specifies the fast interrupt enable for VOUT module

[0] vien – It specifies the fast interrupt enable for VIN module

DESCRIPTIONS

DCM shall follow the interrupt protocol described in interrupt scheme section.

Encoder Parameter Register 0

Address CTR base address + 0x20

Type r/w

31	30	29	28	27	26	25	24	23	22	21	20	19	18	17	16
					vertical_size										
15	14	13	12	11	10	9	8	7	6	5	4	3	2	1	0
					horizontal_size										

[31:27] Reserved

[26:16] vertical_size – It specifies video vertical size in pixel.

[15:11] Reserved

[10:0] horizontal_size – It specifies video horizontal size in pixel.

Encoding Parameter Register 1

Address CTR base address + 0x24

Type r/w

31	30	29	28	27	26	25	24	23	22	21	20	19	18	17	16
rc_type		bframe_num		prog	Initial_QP										
15	14	13	12	11	10	9	8	7	6	5	4	3	2	1	0
frame_rate								IDRPeriod							

[31:30] rc_type – video rate control type: 00 – CQP, 01-CBR, 10- VBR, 11- HBR

[29:28] bframe_num – It specifies how many b frames between two reference frame

[27] prog – It specifies if curren video sequence is progressive video.

1- progressive video

0 – interleaved video

[26:16] Initial_QP – It specifies initial QP for the video encoding

[15:8] frame_rate – It specifies encoding frame rate

[7:0] IDRPeriod – It specifies IDR distance in terms of frame count

Encoder Parameter Register 2

Address CTR base address + 0x28

Type r/w

31	30	29	28	27	26	25	24	23	22	21	20	19	18	17	16
video_bit_rate															

[31:16] reserved

[15:0] video_bit_rate – It specifies current video sequence encoding bit rate in terms of Kbps

Encoder Parameter Register 3

Address CTR base address + 0x2c

Type r/w

31	30	29	28	27	26	25	24	23	22	21	20	19	18	17	16
lp_flag	lp_dis							Loopfilter_AlphaOffset							
15	14	13	12	11	10	9	8	7	6	5	4	3	2	1	0
								Loopfilter_BeltaOffset							

[31] lp_flag

[30] lp_dis – It specifies loop filter disable

[29:24] reserved

[23:16] Loopfilter_AlphaOffset

[15:8] reserved

[7:0] Loopfilter_BeltaOffset

Timer 0 Count

Address CTR base address + 0x30

Type r/w

31	30	29	28	27	26	25	24	23	22	21	20	19	18	17	16
timer_count															
15	14	13	12	11	10	9	8	7	6	5	4	3	2	1	0

[31:0] timer_count – It specifies timer value

Timer 1 Count

Address CTR base address + 0x34

Type r/w

31	30	29	28	27	26	25	24	23	22	21	20	19	18	17	16
timer_count															
15	14	13	12	11	10	9	8	7	6	5	4	3	2	1	0

[31:0] timer_count – It specifies timer value

Timer 2 Count

Address CTR base address + 0x38

Type r/w

31	30	29	28	27	26	25	24	23	22	21	20	19	18	17	16
timer_count															
15	14	13	12	11	10	9	8	7	6	5	4	3	2	1	0

[31:0] timer_count – It specifies timer value

Timer 3 Count

Address CTR base address + 0x3c

Type r/w

31	30	29	28	27	26	25	24	23	22	21	20	19	18	17	16
timer_count															
15	14	13	12	11	10	9	8	7	6	5	4	3	2	1	0

[31:0] timer_count – It specifies timer value

Encoder Parameter Register 4

Address CTR base address + 0x40

Type r/w

31	30	29	28	27	26	25	24	23	22	21	20	19	18	17	16
lp_flag															
15	14	13	12	11	10	9	8	7	6	5	4	3	2	1	0

[31:0] lp_flag

Descriptions:

Please refer to TW2809 SW user manual for more details on how to set encoder paramters.

Encoder Parameter Register 5

Address CTR base address + 0x44

Type r/w

31	30	29	28	27	26	25	24	23	22	21	20	19	18	17	16
lp_flag															
15	14	13	12	11	10	9	8	7	6	5	4	3	2	1	0

[31:0] lp_flag-

Descriptions:

Please refer to TW2809 SW user manual for more details on how to set encoder paramters.

Encoder Parameter Register 6

Address CTR base address + 0x48

Type r/w

31	30	29	28	27	26	25	24	23	22	21	20	19	18	17	16
lp_flag															
15	14	13	12	11	10	9	8	7	6	5	4	3	2	1	0

[31:0] lp_flag

Descriptions:

Please refer to TW2809 SW user manual for more details on how to set encoder paramters.

Encoder Parameter Register 7

Address CTR base address + 0x4c

Type r/w

31	30	29	28	27	26	25	24	23	22	21	20	19	18	17	16
lp_flag															
15	14	13	12	11	10	9	8	7	6	5	4	3	2	1	0

[31:0] lp_flag

Descriptions:

Please refer to TW2809 SW user manual for more details on how to set encoder paramters.

Encoder Parameter Register 8

Address CTR base address + 0x50

Type r/w

31	30	29	28	27	26	25	24	23	22	21	20	19	18	17	16
lp_flag															
15	14	13	12	11	10	9	8	7	6	5	4	3	2	1	0

[31:0] lp_flag

Descriptions:

Please refer to TW2809 SW user manual for more details on how to set encoder paramters.

Encoder Parameter Register 9

Address CTR base address + 0x54

Type r/w

31	30	29	28	27	26	25	24	23	22	21	20	19	18	17	16
lp_flag															
15	14	13	12	11	10	9	8	7	6	5	4	3	2	1	0

[31:0] lp_flag -

Descriptions:

Please refer to TW2809 SW user manual for more details on how to set encoder paramters.

Encoder Parameter Register 10

Address CTR base address + 0x58

Type r/w

31	30	29	28	27	26	25	24	23	22	21	20	19	18	17	16
lp_flag															
15	14	13	12	11	10	9	8	7	6	5	4	3	2	1	0

[31:0] lp_flag

Descriptions:

Please refer to TW2809 SW user manual for more details on how to set encoder paramters.

Encoder Parameter Register 11

Address CTR base address + 0x5c

Type r/w

31	30	29	28	27	26	25	24	23	22	21	20	19	18	17	16
lp_flag															
15	14	13	12	11	10	9	8	7	6	5	4	3	2	1	0

[31:0] lp_flag

Descriptions:

Please refer to TW2809 SW user manual for more details on how to set encoder paramters.

Encoder Parameter Register 12

Address CTR base address + 0x60

Type r/w

31	30	29	28	27	26	25	24	23	22	21	20	19	18	17	16
lp_flag															
15	14	13	12	11	10	9	8	7	6	5	4	3	2	1	0

[31:0] lp_flag

Descriptions:

Please refer to TW2809 SW user manual for more details on how to set encoder paramters.

Watch Dog Limit

Address CTR base address + 0x64

Type r/w

31	30	29	28	27	26	25	24	23	22	21	20	19	18	17	16
watch_dog_limit															
15	14	13	12	11	10	9	8	7	6	5	4	3	2	1	0

[31:0] watch_dog_limit – It species the watch dog interrupt counter value. If watch dog counter reaches this value, it will raise interrupt to host.

Timer Control Register

Address CTR base address + 0x68

Type r/w

31	30	29	28	27	26	25	24	23	22	21	20	19	18	17	16
wdg_en												go3	go2	go1	go0
15	14	13	12	11	10	9	8	7	6	5	4	3	2	1	0
												hold3	hold2	hold1	hold0

[31] wdg_en – It species watch dog enable

[30:20] reserved

[19] go3 – It species timer3 control *go* signal

[18] go2 – It species timer2 control *go* signal

[17] go1 – It species timer1 control *go* signal

[16] go0 – It species timer0 control *go* signal

[15:4] reserved

[3] hold3 – It species timer3 control *hold* signal

[2] hold2 – It species timer2 control *hold* signal

[1] hold1 – It species timer1 control *hold* signal

[0] hold0 – It species timer0 control *hold* signal

DESCRIPTIONS

hold – It species timer hold control. This is a level control signal

0 : counter is disabled and held in the current state

1: counter is allowed to count

go – It resets and starts the timer counter. This is a pulse control register

0 : no effects on the timers

1: if hold is HIGH, the counter register is zeroed and begins counting on the next clock.

Timer 1 Control Register

Address CTR base address + 0x44

Type r/w

31	30	29	28	27	26	25	24	23	22	21	20	19	18	17	16
														1	0
15	14	13	12	11	10	9	8	7	6	5	4	3	2	1	0
														hold	go

[31:2] reserved

[1] hold – It species timer hold control. This is a level control signal

0 : counter is disabled and held in the current state

1: counter is allowed to count

[0] go – It resets and starts the timer counter. This is a pulse control register

0 : no effects on the timers

1: if hold is HIGHT, the counter register is zeroed and begins counting on the next clock.

Timer 2 Control Register

Address CTR base address + 0x48

Type r/w

31	30	29	28	27	26	25	24	23	22	21	20	19	18	17	16
														1	0
15	14	13	12	11	10	9	8	7	6	5	4	3	2	1	0
														hold	go

[31:2] reserved

[1] hold – It species timer hold control. This is a level control signal

0 : counter is disabled and held in the current state

1: counter is allowed to count

[0] go – It resets and starts the timer counter. This is a pulse control register

0 : no effects on the timers

1: if hold is HIGHT, the counter register is zeroed and begins counting on the next clock.

Timer 3 Control Register

Address CTR base address + 0x4c

Type r/w

31	30	29	28	27	26	25	24	23	22	21	20	19	18	17	16
														1	0
														hold	go

[31:2] reserved

[1] hold – It species timer hold control. This is a level control signal

0 : counter is disabled and held in the current state

1: counter is allowed to count

[0] go – It resets and starts the timer counter. This is a pulse control register

0 : no effects on the timers

1: if hold is HIGHT, the counter register is zeroed and begins counting on the next clock.

Host Interface Register Definitions

This section describes host interface module registers. The HIF register space is partitioned into three sections:

1. Normal HIF register space
2. PDMA slave register space
3. PDMA master register space

The PDMA register space is defined in the next chapter.

HIF Interrupt

Address HIF_Baseaddress + 0x00

Type ro

31	30	29	28	27	26	25	24	23	22	21	20	19	18	17	16
								tx_f	mx_f	tr_e	tx_e	mr_e	mx_e	c_busy	int
15	14	13	12	11	10	9	8	7	6	5	4	3	2	1	0
															int_e

[31:24] reserved

[23] tx_f – It specifies target transmit buffer fullness.

1 : the buffer is full. 0 : the buffer is not full

[22] mx_f – It specifies master transmit buffer fullness.

1 : the buffer is full. 0 : the buffer is not full

[21] tr_e – It specifies target receiving buffer emptiness.

1 : the buffer is empty. 0 : the buffer is not empty

[20] tx_e – It specifies target transmit buffer emptiness.

1 : the buffer is empty. 0 : the buffer is not empty

[19] mr_e – It specifies master receiving buffer emptiness.

1 : the buffer is empty. 0 : the buffer is not empty

[18] mx_e – It specifies master transmit buffer emptiness.

1 : the buffer is empty. 0 : the buffer is not empty

[17] c_busy – *CBUS masters can only read this bit.* If this bit is HIGH, cbus master can not issue next serial flash command.

[16] int – It specifies HIF interrupt

[15:1] reserved

[0] int_e – It specifies HIF interrupt enable. 0: interrupt disable. 1: interrupt enable. Default is 1.

DESCRIPTIONS

HIF shall follow the interrupt protocol described in interrupt scheme section.

Device ID

Address HIF_Baseaddress + 0x04

Type ro

31	30	29	28	27	26	25	24	23	22	21	20	19	18	17	16
device_id															
15	14	13	12	11	10	9	8	7	6	5	4	3	2	1	0
vendor_id															

[31:16] device_id – It specifies device ID. Default is 0x2809

[15:0] vendor_id – It specifies vendor ID. Default is 0x1797

PCI Class Code

Address HIF_Baseaddress + 0x08

Type ro

31	30	29	28	27	26	25	24	23	22	21	20	19	18	17	16
15	14	13	12	11	10	9	8	7	6	5	4	3	2	1	0
class_code															

[31:24] reserved

[23:0] class code – It specifies PCI class code. The default value is 0x48000

PCI Sub-system ID

Address HIF_Baseaddress + 0x0c

Type ro

31	30	29	28	27	26	25	24	23	22	21	20	19	18	17	16
Subsys_id															
15	14	13	12	11	10	9	8	7	6	5	4	3	2	1	0
Subsys_vendor_id															

[31:16] subsys_id – It specifies PCI subsystem ID. Default is 0x2809

[15:0] subsys_vendor_id – It specifies PCI subsystem vendor ID. Default is 0x1797

PCI Header Info

Address HIF_Baseaddress + 0x10

Type ro

31	30	29	28	27	26	25	24	23	22	21	20	19	18	17	16
header								rev_id							
15	14	13	12	11	10	9	8	7	6	5	4	3	2	1	0
max_lat								min_gnt							

[31:24] header – It specifies PCI header

[23:16] rev_id – It specifies revision ID

[15:8] max_lat – It specifies PCI max latency

[23:16] min_gnt – It specifies PCI min grant timing

DDR Mode Register

Address HIF base address + 0x14

Type r/w

31	30	29	28	27	26	25	24	23	22	21	20	19	18	17	16
15	14	13	12	11	10	9	8	7	6	5	4	3	2	1	0
MR			PD	WR			DLL	TM	CL			BT	BL		

[31:16] reserved

[15:14] MR – It specifies mode register definition

MR	mode register definition
0 0	Mode register (MR)
0 1	Extended mode register (EMR)
1 0	Extended mode register (EMR2)
1 1	Extended mode register (EMR3)

[13] reserved

[12] PD – It specifies PD mode. 0: fast exit, 1: slow exit

[11:9] WR – It specifies the write recovery

WR	Write recovery
0 0 0	reserved
0 0 1	2
0 1 0	3
0 1 1	4
1 0 0	5
1 0 1	6
1 1 0	reserved
1 1 1	Reserved

[8] DLL – It specifies the DLL reset. 0: No, 1: Yes

[7] TM – It specifies test mode. 0: Normal operation, 1: test

[6:4] CL – It specifies the CAS latency

CL	cas latency
0 0 0	reserved
0 0 1	reserved
0 1 0	reserved
0 1 1	3
1 0 0	4
1 0 1	5
1 1 0	6
1 1 1	Reserved

[3] BT – It specifies burst type. 0: sequential, 1: interleaved

[2:0] BL – It specifies the burst length

BL	burst length
0 0 0	reserved
0 0 1	reserved
0 1 0	4
0 1 1	8
1 0 0	reserved
1 0 1	reserved
1 1 0	reserved
1 1 1	Reserved

DDR Timing Control Register 0

Address HIF base address + 0x18

Type r/w

31	30	29	28	27	26	25	24	23	22	21	20	19	18	17	16
wtr		wl				rfc						rc			
15	14	13	12	11	10	9	8	7	6	5	4	3	2	1	0
rp				rcd				ras				rrd		half_cl	

[31:30] wtr – write recovery time

[29:26] wl – write latency

[25:20] rfc - refresh interval

[19:16] rc – activate to activate delay (same bank)

[15:12] rp – precharge period

[11:8] rcd – activate to read or write delay

[7:4] ras – activate to precharge delay

[3:2] rrd – activate to activate delay (different bank)

[1:0] half_cl – half cas latency

DESCRIPTIONS

FW programs DDR timing control register based on DDR speed grade. All timing parameters need to be converted into cycle count in the current core frequency. These parameters are DDR vendor dependent and please refer to TW2809 application note for more details.

DDR Timing Control Register 1

Address HIF base address + 0x1c

Type r/w

31	30	29	28	27	26	25	24	23	22	21	20	19	18	17	16
												mrd			
15	14	13	12	11	10	9	8	7	6	5	4	3	2	1	0
power_up_delay															

[31:20] reserved

[19:16] mrd- load mode cycle time

[15:0] power_up_delay- ddr power up delay cycle

DESCRIPTIONS

FW programs DDR timing control register based on DDR speed grade. All timing parameters need to be converted into cycle count in the current core frequency. These parameters are DDR vendor dependent and please refer to TW2809 application note for more details.

FW PDMA Control Register

Address HIF base address + 0x24

Type r/w

31	30	29	28	27	26	25	24	23	22	21	20	19	18	17	16
INT_EN	-														
15	14	13	12	11	10	9	8	7	6	5	4	3	2	1	0
-													T_TYPE	R/W	GO

[31] INT_EN – Interrupt enable bit. When F/W want to finish PDMA access and GO bit is disables, Interrupt is assert to ARM after the last transfer.

[30:3] reserved

[2] T_TYPE – Power PC interface type.

“00”: Interrupt is assert to Power PC when PDMA's FIFO is prepared data.

“01”: Interrupt is only assert to Power PC when PDMA prepare the first 64 words.

[1] R/W – Read or Write select bit. When this bit is set, Data in External memory is transferred to the Power PC.

[0] GO – DMA request. User should enable the bit after PDMA Command register is written. When this bit is disables, PDMA transfer is disabled.

FW PDMA Command Register

Address HIF base address + 0x28

Type r/w

31	30	29	28	27	26	25	24	23	22	21	20	19	18	17	16
-															
15	14	13	12	11	10	9	8	7	6	5	4	3	2	1	0
										BUF_ID					

[31:6] reserved

[5:0] BUF_ID – Linear buffer id (up to 64 linear buffer)

I2C Register Definitions

I2C Interrupt Register

Address I2C_Baseaddress + 0x00

Type r/w

31	30	29	28	27	26	25	24	23	22	21	20	19	18	17	16
														I2C rd interrupt status (clear)	I2C wr interrupt status(clea r)
15	14	13	12	11	10	9	8	7	6	5	4	3	2	1	0
														I2C rd interrupt enable	I2C wr interrupt enable

- [17] I2C Read Interrupt Status (Clear) -- FW wirte HIGH to clear
1 : happened I2C read interrupt (The Status bit can be cleared by writing bit 17 "1".)
- [16] I2C Write Interrupt Status(Clear) -- FW wirte HIGH to clear
1 : happened I2C write interrupt (The Status bit can be cleared by writing bit 16 "1".)
- [1] I2C Read Interrupt Enable – FW wirte HIGH to enable
- [0] I2C Write Interrupt Enable – FW wirte HIGH to enable

DESCRIPTIONS

I2C Read/Write Interrupt Status bits can be cleared by ARM

I2C Mode Select Register

Address I2C_Baseaddress + 0x04

Type r/w

31	30	29	28	27	26	25	24	23	22	21	20	19	18	17	16
															0
15	14	13	12	11	10	9	8	7	6	5	4	3	2	1	0
															Master/slave mode select

[00] Master/Slave mode select

DESCRIPTIONS

“1” is Master mode, “0” is Slave mode. Default is “1”.

I2C Slave Address

Slave Address							R/W
0	1	1	1	1	0	0	1 = Read 0 = Write

I2C Write Register0, Register1, Register2, Register3

Address I2C_Baseaddress + 0x20

Type I2C write/ARM read

31	30	29	28	27	26	25	24	23	22	21	20	19	18	17	16
Write Reg3								Write Reg2							
15	14	13	12	11	10	9	8	7	6	5	4	3	2	1	0
Write Reg1								Write Reg 0							

[31:24] Write Reg31 – I2C write data byte 3

[23:16] Write Reg30– I2C write data byte 2

[15:8] Write Reg29– I2C write data byte 1

[7:0] Write Reg28– I2C write data byte 0

DESCRIPTIONS

I2C writes to this register and FW read from this register.

I2C Write Register4, Register5, Register6, Register7

Address I2C_Baseaddress + 0x24

Type I2C write/ARM read

31	30	29	28	27	26	25	24	23	22	21	20	19	18	17	16
Write Reg7								Write Reg6							
15	14	13	12	11	10	9	8	7	6	5	4	3	2	1	0
Write Reg5								Write Reg 4							

[31:24] Write Reg31 - I2C write data byte 7

[23:16] Write Reg30- I2C write data byte 6

[15:8] Write Reg29- I2C write data byte 5

[7:0] Write Reg28- I2C write data byte 4

DESCRIPTIONS

I2C writes to this register and FW read from this register.

I2C Write Register8, Register9, Register10, Register11

Address I2C_Baseaddress + 0x28

Type I2C write/ARM read

31	30	29	28	27	26	25	24	23	22	21	20	19	18	17	16
Write Reg11								Write Reg10							
15	14	13	12	11	10	9	8	7	6	5	4	3	2	1	0
Write Reg9								Write Reg 8							

[31:24] Write Reg31 - I2C write data byte 11

[23:16] Write Reg30- I2C write data byte 10

[15:8] Write Reg29- I2C write data byte 9

[7:0] Write Reg28- I2C write data byte 8

DESCRIPTIONS

I2C writes to this register and FW read from this register.

I2C Write Register12, Register13, Register14, Register15

Address I2C_Baseaddress + 0x2C

Type I2C write/ARM read

31	30	29	28	27	26	25	24	23	22	21	20	19	18	17	16
Write Reg15								Write Reg14							
15	14	13	12	11	10	9	8	7	6	5	4	3	2	1	0
Write Reg13								Write Reg12							

[31:24] Write Reg31 - I2C write data byte 15

[23:16] Write Reg30- I2C write data byte 14

[15:8] Write Reg29- I2C write data byte 13

[7:0] Write Reg28- I2C write data byte 12

DESCRIPTIONS

I2C writes to this register and FW read from this register.

I2C Write Register16, Register17, Register18, Register19

Address I2C_Baseaddress + 0x30

Type I2C write/ARM read

31	30	29	28	27	26	25	24	23	22	21	20	19	18	17	16
Write Reg19								Write Reg18							
15	14	13	12	11	10	9	8	7	6	5	4	3	2	1	0
Write Reg17								Write Reg16							

[31:24] Write Reg31 - I2C write data byte 19

[23:16] Write Reg30- I2C write data byte 18

[15:8] Write Reg29- I2C write data byte 17

[7:0] Write Reg28- I2C write data byte 16

DESCRIPTIONS

I2C writes to this register and FW read from this register.

I2C Write Register20, Register21, Register22, Register23

Address I2C_Baseaddress + 0x34

Type I2C write/ARM read

31	30	29	28	27	26	25	24	23	22	21	20	19	18	17	16
Write Reg23								Write Reg22							
15	14	13	12	11	10	9	8	7	6	5	4	3	2	1	0
Write Reg21								Write Reg20							

[31:24] Write Reg31 - I2C write data byte 23

[23:16] Write Reg30- I2C write data byte 22

[15:8] Write Reg29- I2C write data byte 21

[7:0] Write Reg28- I2C write data byte 20

DESCRIPTIONS

I2C writes to this register and FW read from this register.

I2C Write Register24, Register25, Register26, Register27

Address I2C_Baseaddress + 0x38

Type I2C write/ARM read

31	30	29	28	27	26	25	24	23	22	21	20	19	18	17	16
Write Reg27								Write Reg26							
15	14	13	12	11	10	9	8	7	6	5	4	3	2	1	0
Write Reg25								Write Reg24							

[31:24] Write Reg31 - I2C write data byte 27

[23:16] Write Reg30- I2C write data byte 26

[15:8] Write Reg29- I2C write data byte 25

[7:0] Write Reg28- I2C write data byte 24

DESCRIPTIONS

I2C writes to this register and FW read from this register.

I2C Write Register28, Register29, Register30, Register31

Address I2C_Baseaddress + 0x3C

Type I2C write/ARM read

31	30	29	28	27	26	25	24	23	22	21	20	19	18	17	16
Write Reg31								Write Reg30							
15	14	13	12	11	10	9	8	7	6	5	4	3	2	1	0
Write Reg29								Write Reg28							

[31:24] Write Reg31 - I2C write data byte 31

[23:16] Write Reg30- I2C write data byte 30

[15:8] Write Reg29- I2C write data byte 29

[7:0] Write Reg28- I2C write data byte 28

DESCRIPTIONS

I2C writes to this register and FW read from this register.

I2C Read Register0, Register1, Register2, Register3

Address I2C_Baseaddress + 0x80

Type I2C read/ARM write

31	30	29	28	27	26	25	24	23	22	21	20	19	18	17	16
Read Reg3								Read Reg2							
15	14	13	12	11	10	9	8	7	6	5	4	3	2	1	0
Read Reg1								Read Reg0							

[31:24] Read Reg3 - I2C read data byte 3

[23:16] Read Reg2- I2C read data byte 2

[15:8] Read Reg1- I2C read data byte 1

[7:0] Read Reg0- I2C read data byte 0

DESCRIPTIONS

ARM writes this register and I2C reads from this register

I2C Read Register4, Register5, Register6, Register7

Address I2C_Baseaddress + 0x84

Type I2C read/ARM write

31	30	29	28	27	26	25	24	23	22	21	20	19	18	17	16
Read Reg7								Read Reg6							
15	14	13	12	11	10	9	8	7	6	5	4	3	2	1	0
Read Reg5								Read Reg4							

[31:24] Read Reg3 – I2C read data byte 7

[23:16] Read Reg2– I2C read data byte 6

[15:8] Read Reg1– I2C read data byte 5

[7:0] Read Reg0– I2C read data byte 4

DESCRIPTIONS

ARM writes this register and I2C reads from this register

I2C Read Register8, Register9, Register10, Register11

Address I2C_Baseaddress + 0x88

Type I2C read/ARM write

31	30	29	28	27	26	25	24	23	22	21	20	19	18	17	16
Read Reg11								Read Reg10							
15	14	13	12	11	10	9	8	7	6	5	4	3	2	1	0
Read Reg9								Read Reg8							

[31:24] Read Reg3 – I2C read data byte 11

[23:16] Read Reg2– I2C read data byte 10

[15:8] Read Reg1– I2C read data byte 9

[7:0] Read Reg0– I2C read data byte 8

DESCRIPTIONS

ARM writes this register and I2C reads from this register

I2C Read Register12, Register13, Register14, Register15

Address I2C_Baseaddress + 0x8C

Type I2C read/ARM write

31	30	29	28	27	26	25	24	23	22	21	20	19	18	17	16
Read Reg15								Read Reg14							
15	14	13	12	11	10	9	8	7	6	5	4	3	2	1	0
Read Reg13								Read Reg12							

[31:24] Read Reg3 – I2C read data byte 15

[23:16] Read Reg2– I2C read data byte 14

[15:8] Read Reg1– I2C read data byte 13

[7:0] Read Reg0– I2C read data byte 12

DESCRIPTIONS

ARM writes this register and I2C reads from this register

I2C Read Register16, Register17, Register18, Register19

Address I2C_Baseaddress + 0x90

Type I2C read/ARM write

31	30	29	28	27	26	25	24	23	22	21	20	19	18	17	16
Read Reg19								Read Reg18							
15	14	13	12	11	10	9	8	7	6	5	4	3	2	1	0
Read Reg17								Read Reg16							

[31:24] Read Reg3 – I2C read data byte 19

[23:16] Read Reg2– I2C read data byte 18

[15:8] Read Reg1– I2C read data byte 17

[7:0] Read Reg0– I2C read data byte 16

DESCRIPTIONS

ARM writes this register and I2C reads from this register

I2C Read Register20,Register21,Register22,Register23

Address I2C_Baseaddress + 0x94

Type I2C read/ARM write

31	30	29	28	27	26	25	24	23	22	21	20	19	18	17	16
Read Reg23								Read Reg22							
15	14	13	12	11	10	9	8	7	6	5	4	3	2	1	0
Read Reg21								Read Reg20							

[31:24] Read Reg3 – I2C read data byte 23

[23:16] Read Reg2– I2C read data byte 22

[15:8] Read Reg1– I2C read data byte 21

[7:0] Read Reg0– I2C read data byte 20

DESCRIPTIONS

ARM writes this register and I2C reads from this register

I2C Read Register24,Register25,Register26,Register27

Address I2C_Baseaddress + 0x98

Type I2C read/ARM write

31	30	29	28	27	26	25	24	23	22	21	20	19	18	17	16
Read Reg27								Read Reg26							
15	14	13	12	11	10	9	8	7	6	5	4	3	2	1	0
Read Reg25								Read Reg 24							

[31:24] Read Reg3 – I2C read data byte 27

[23:16] Read Reg2– I2C read data byte 26

[15:8] Read Reg1– I2C read data byte 25

[7:0] Read Reg0– I2C read data byte 24

DESCRIPTIONS

ARM writes this register and I2C reads from this register

I2C Read Register28, Register29, Register30, Register31

Address I2C_Baseaddress + 0x9C

Type I2C read/ARM write

31	30	29	28	27	26	25	24	23	22	21	20	19	18	17	16
Read Reg31								Read Reg30							
15	14	13	12	11	10	9	8	7	6	5	4	3	2	1	0
Read Reg29								Read Reg28							

[31:24] Read Reg3 - I2C read data byte 31

[23:16] Read Reg2- I2C read data byte 30

[15:8] Read Reg1- I2C read data byte 29

[7:0] Read Reg0- I2C read data byte 28

DESCRIPTIONS

ARM writes this register and I2C reads from this register

I2C Master Mode Protocol

I2C Master Mode Protocol is for I2C read/write SOC internal registers.

From the I2C interface waveform, it should be the following protocol to finish read/write operations.

WRITE CBUS 32 BIT REGISTERS:

I2C start

Byte 0: I2C device ID (7'b01111100) + 1'b0

Byte1 : 8'h00

Byte 2: cbus_addr[7:0]

Byte 3: cbus_addr[15:8]

Byte 4: cbus_addr[23:16]

Byte 5: cbus_addr[31:24]

Byte 6: cbus_wdata[7:0]

Byte 7: cbus_wdata[15:8]

Byte 8: cbus_wdata[23:16]

Byte 9: cbus_wdata[31:24]

Byte a: 8'h01 (This is write command)

I2C stop

READ CBUS 32 BIT REGISTERS:

I2C start

Byte 0: I2C device ID (7'b01111100) + 1'b0

Byte 1: 8'h00

Byte 2: cbus_addr[7:0]

Byte 3: cbus_addr[15:8]

Byte 4: cbus_addr[23:16]

Byte 5: cbus_addr[31:24]

I2C stop

I2C start

Byte 0: I2C device ID (7'b01111100) + 1'b0

Byte 1: 8'h08

Byte 2: 8'h00 (this is read command)

I2C stop

I2C start

Byte 0: I2C device ID (7'b01111100) + 1'b0

Byte 1: 8'h00

I2C stop

I2C start

Byte 0: I2C device ID (7bit) + 1'b1

Byte 1: read cbus_rdata[7:0]

Byte 2: read cbus_rdata[15:8]

Byte 3: read cbus_rdata[23:16]

Byte 4: read cbus_rdata[31:24]

I2C stop

UART Register Definitions

UART Interrupt Enable Register

Address UART_Baseaddress + 0x00

Type r/w

31	30	29	28	27	26	25	24	23	22	21	20	19	18	17	16
15	14	13	12	11	10	9	8	7	6	5	4	3	2	1	0
															UART Interrupt Enable

[0] UART Interrupt Enable

DESCRIPTIONS

UART Interrupt can be enabled by writing bit 0 "1".

UART Interrupt Status Register

Address UART_Baseaddress + 0x04

Type r/w

31	30	29	28	27	26	25	24	23	22	21	20	19	18	17	16
15	14	13	12	11	10	9	8	7	6	5	4	3	2	1	0
															UART Interrupt Status

[0] UART Interrupt Status

DESCRIPTIONS

UART Interrupt Status bit can be cleared by writing bit 0 "1".

UART Line Control Register(LCR)

Address UART_Baseaddress + 0x2C

Type r/w

31	30	29	28	27	26	25	24	23	22	21	20	19	18	17	16
15	14	13	12	11	10	9	8	7	6	5	4	3	2	1	0
								Divisor Latch Access bit	Break Control bit	Stick Parity bit.	Even Parity select	Parity Enable	Specify the number of generated stop bits	Select number of bits in each character	

- [7] **Divisor Latch Access bit.**
 '1' – The divisor latches can be accessed
 '0' – The normal registers are accessed
- [6] **Break Control bit**
 '1' – the serial out is forced into logic '0' (break state).
 '0' – break is disabled
- [5] **Stick Parity bit.**
 '0' – Stick Parity disabled
 '1' - If bits 3 and 4 are logic '1', the parity bit is transmitted and checked as logic
 '0'. If bit 3 is '1' and bit 4 is '0' then the parity bit is transmitted and checked as '1'.
- [4] **Even Parity select**
 '0' – Odd number of '1' is transmitted and checked in each word (data and parity combined). In other words, if the data has an even number of '1' in it, then the parity bit is '1'.
 '1' – Even number of '1' is transmitted in each word.
- [3] **Parity Enable**
 '0' – No parity
 '1' – Parity bit is generated on each outgoing character and is checked on each incoming one.
- [2] **Specify the number of generated stop bits**
 '0' – 1 stop bit
 '1' – 1.5 stop bits when 5-bit character length selected and 2 bits otherwise
- Note that the receiver always checks the first stop bit only.
- [1:0] **Select number of bits in each character**
 '00' – 5 bits
 '01' – 6 bits
 '10' – 7 bits
 '11' – 8 bits

DESCRIPTIONS

The line control register allows the specification of the format of the asynchronous data communication used. A bit in the register also allows access to the Divisor Latches, which define the baud rate. Reading from the register is allowed to check the current settings of the communication.

Reset Value: 00000011b

UART Divisor Latch Byte 1 Register(LSB)

Address UART_Baseaddress + 0x20

Type r/w

31	30	29	28	27	26	25	24	23	22	21	20	19	18	17	16
15	14	13	12	11	10	9	8	7	6	5	4	3	2	1	0
								The LSB of the divisor latch							

[7:0] The LSB of the divisor latch – See descriptions below

DESCRIPTIONS

There are 2 Clock Divisor registers that together form one 16-bit. The registers can be accessed when the 7th (DLAB) bit of the Line Control Register is set to '1'. At this time the above registers at addresses 0-1 can't be accessed.

The divisor latches can be accessed by setting the 7th bit of LCR to '1'. You should restore this bit to '0' after setting the divisor latches in order to restore access to the other registers that occupy the same addresses. The 2 bytes form one 16-bit register, which is internally accessed as a single number. You should therefore set all 2 bytes of the register to ensure normal operation. The register is set to the default value of 0 on reset, which disables all serial I/O operations in order to ensure explicit setup of the register in the software. The value set should be equal to (system clock speed) / (16 x desired baud rate).

The internal counter starts to work when the LSB of DL is written, so when setting the divisor, write the MSB first and the LSB last.

UART Divisor Latch Byte 2 Register (MSB)

Address UART_Baseaddress + 0x24

Type r/w

31	30	29	28	27	26	25	24	23	22	21	20	19	18	17	16
15	14	13	12	11	10	9	8	7	6	5	4	3	2	1	0
								The MSB of the divisor latch							

[7:0] The MSB of the divisor latch – See descriptions below

DESCRIPTIONS

There are 2 Clock Divisor registers that together form one 16-bit. The registers can be accessed when the 7th (DLAB) bit of the Line Control Register is set to '1'. At this time the above registers at addresses 0-1 can't be accessed.

The divisor latches can be accessed by setting the 7th bit of LCR to '1'. You should restore this bit to '0' after setting the divisor latches in order to restore access to the other registers that occupy the same addresses. The 2 bytes form one 16-bit register, which is internally accessed as a single number. You should therefore set all 2 bytes of the register to ensure normal operation. The register is set to the default value of 0 on reset, which disables all serial I/O operations in order to ensure explicit setup of the register in the software. The value set should be equal to (system clock speed) / (16 x desired baud rate).

The internal counter starts to work when the LSB of DL is written, so when setting the divisor, write the MSB first and the LSB last.

UART Internal Interrupt Enable Register(IER)

Address UART_Baseaddress + 0x24

Type r/w

31	30	29	28	27	26	25	24	23	22	21	20	19	18	17	16
15	14	13	12	11	10	9	8	7	6	5	4	3	2	1	0
								Reserved. Should be logic '0'.				Modem Status Interrupt	Receiver Line Status Interrupt	Transmitter Holding Register empty interrupt	Received Data available interrupt

[7: 4] Reserved. Should be logic '0'.

[3] **Modem Status Interrupt**
 '0' - disabled
 '1' - enabled

[2] **Receiver Line Status Interrupt**
 '0' - disabled
 '1' - enabled

[1] **Transmitter Holding Register empty interrupt**
 '0' - disabled
 '1' - enabled

[0] **Received Data available interrupt**
 '0' - disabled
 '1' - enabled

DESCRIPTIONS

Reset Value: 00h

UART Interrupt Identification Register(IIR)

Address UART_Baseaddress + 0x28

Type r/w

31	30	29	28	27	26	25	24	23	22	21	20	19	18	17	16
15	14	13	12	11	10	9	8	7	6	5	4	3	2	1	0
								Reserved. Should be logic '1' for compatibility		Reserved. Should be logic '0'.		Bit 3	Bit 2	Bit 1	Bit 0

[7:6] Reserved – Should be logic '1' for compatibility

[5:4] Reserved – Should be logic '0'

[3:1] Bit 3/2/1 - The following table displays the list of possible interrupts along with the bits they enable, priority, and their source and reset control.

[0] Bit 0 - It indicates that an interrupt is pending when it's logic '0'.

 When it's '1' – no interrupt is pending.

Bit 3	Bit 2	Bit 1	Priority	Interrupt Type	Interrupt Source	Interrupt Reset
0	1	1	1st	Receiver Line Status	Parity, Overrun or Framing errors or Break Interrupt	Reading the Line Status Register
0	1	0	2nd	Receiver Data available	FIFO trigger level reached	FIFO drops below trigger level
1	1	0	2nd	Timeout Indication	There's at least 1 character in the FIFO but no character has been input to the FIFO or read from it for the last 4 Char times.	Reading from the FIFO (Receiver Buffer Register)
0	0	1	3rd	Transmitter Holding Register empty	Transmitter Holding Register Empty	Writing to the Transmitter Holding Register or reading IIR.
0	0	0	4th	Modem Status	CTS, DSR, RI or DCD.	Reading the Modem status register.

DESCRIPTIONS

The IIR enables the programmer to retrieve what is the current highest priority pending interrupt.

Reset Value: C1h

UART FIFO Control Register(FCR)

Address UART_Baseaddress + 0x28

Type write

31	30	29	28	27	26	25	24	23	22	21	20	19	18	17	16
15	14	13	12	11	10	9	8	7	6	5	4	3	2	1	0
								Define the Receiver FIFO Interrupt trigger level	Ignored			CLR_TX_FIFO	CLR_RX_FIFO	Ignored	

[7:6] Define the Receiver FIFO Interrupt trigger level

- '00' - 1 byte
- '01' - 4 bytes
- '10' - 8 bytes
- '11' - 14 bytes

[5:3] Ignored

[2] CLR_TX_FIFO - Writing a '1' to bit 2 clears the Transmitter FIFO and resets its logic.
The shift register is not cleared, i.e. transmitting of the current character continues.

[1] CLR_RX_FIFO - Writing a '1' to bit 1 clears the Receiver FIFO and resets its logic.
But it doesn't clear the shift register, i.e. receiving of the current character continues.

[0] Ignored - (Used to enable FIFOs in NS16550D).
Since this UART only supports FIFO mode, this bit is ignored.

DESCRIPTIONS

Reset Value : 11000000b

UART Modem Control Register(MCR)

Address UART_Baseaddress + 0x30

Type write

31	30	29	28	27	26	25	24	23	22	21	20	19	18	17	16
15	14	13	12	11	10	9	8	7	6	5	4	3	2	1	0
								Ignored		Loopback		Out2	Out1	RTS_CTRL	DTR_CTRL

[7:5] Ignored

[4] **Loopback - Loop back mode.** '0' – normal operation, '1' – loopback mode.

When in loopback mode, the Serial Output Signal (STX_PAD_O) is set to logic '1'.
The signal of the transmitter shift register is internally connected to the input of the receiver shift register.

The following connections are made:

DTR \square DSR }, { RTS \square CTS }, { Out1 \square RI }, { Out2 \square DCD }

[3] **Out2** - In loopback mode, connected to Data Carrier Detect (DCD) input.

[2] **Out1** - In loopback mode, connected Ring Indicator (RI) signal input

[1] **RTS_CTRL** - Request To Send (RTS) signal control. '0' – RTS is '1', '1' – RTS is '0'

[0] **DTR_CTRL** - Data Terminal Ready (DTR) signal control. '0' – DTR is '1', '1' – DTR is '0'

DESCRIPTIONS

Reset Value: 0

UART Line Status Register(LSR)

Address UART_Baseaddress + 0x34

Type read

31	30	29	28	27	26	25	24	23	22	21	20	19	18	17	16
15	14	13	12	11	10	9	8	7	6	5	4	3	2	1	0
								All Error Indicator	Transmitter Empty indicator	Transmit FIFO is empty	Break Interrupt (BI) indicator	Framing Error (FE) indicator	Parity Error (PE) indicator	Overrun Error (OE) indicator	Data Ready (DR) indicator

[7] All Error Indicator

- '1' – At least one parity error, framing error or break indications have been received and are inside the FIFO. The bit is cleared upon reading from the register.
- '0' – Otherwise.

[6] Transmitter Empty indicator

- '1' – Both the transmitter FIFO and transmitter shift register are empty. The bit is cleared when data is being written to the transmitter FIFO.
- '0' – Otherwise

[5] Transmit FIFO is empty.

- '1' – The transmitter FIFO is empty. Generates Transmitter Holding Register Empty interrupt. The bit is cleared when data is being written to the transmitter FIFO.
- '0' – Otherwise

[4] Break Interrupt (BI) indicator

- '1' – A break condition has been reached in the current character. The break occurs when the line is held in logic 0 for a time of one character (start bit + data + parity + stop bit). In that case, one zero character enters the FIFO and the UART waits for a valid start bit to receive next character. The bit is cleared upon reading from the register. Generates Receiver Line Status interrupt.
- '0' – No break condition in the current character

[3] Framing Error (FE) indicator

- '1' – The received character at the top of the FIFO did not have a valid stop bit. Of course, generally, it might be that all the following data is corrupt. The bit is cleared upon reading from the register. Generates Receiver Line Status interrupt.
- '0' – No framing error in the current character

[2] Parity Error (PE) indicator

- '1' – The character that is currently at the top of the FIFO has been received with parity error. The bit is cleared upon reading from the register. Generates Receiver Line Status interrupt.
- '0' – No parity error in the current character

[1] Overrun Error (OE) indicator

- '1' – If the FIFO is full and another character has been received in the receiver shift register. If another character is starting to arrive, it will overwrite the data in the shift register but the FIFO will remain intact. The bit is cleared upon reading from the register. Generates Receiver Line Status interrupt.
- '0' – No overrun state

- [0] Data Ready (DR) indicator.
 - '1' – At least one character has been received and is in the FIFO.
 - '0' – No characters in the FIFO

DESCRIPTIONS

The register displays the current state of UART line.

UART Modem Status Register(MSR)

Address UART_Baseaddress + 0x38

Type read

31	30	29	28	27	26	25	24	23	22	21	20	19	18	17	16
15	14	13	12	11	10	9	8	7	6	5	4	3	2	1	0
								COMP_ DCD	COMP_ RI	COMP_ DSR	COMP_ CTS	DDCD Indicator	TERI Detector	DDSR Indicator	DCTS Indicator

- [7] **COMP_DCD** - Complement of the DCD input or equals to Out2 in loopback mode.
- [6] **COMP_RI** - Complement of the RI input or equals to Out1 in loopback mode.
- [5] **COMP_DSR** - Complement of the DSR input or equals to DTR in loopback mode.
- [4] **COMP_CTS** - Complement of the CTS input or equals to RTS in loopback mode.
- [3] **DDCD Indicator** - Delta Data Carrier Detect (DDCD) indicator
 '1' - The DCD line has changed its state.
- [2] **TERI Detector** - Trailing Edge of Ring Indicator (TERI) detector.
 The RI line has changed its state from low to high state.
- [1] **DDSR Indicator** - Delta Data Set Ready (DDSR) indicator
 '1' - The DSR line has changed its state.
- [0] **DCTS Indicator** - Delta Clear To Send (DCTS) indicator
 '1' - The CTS line has changed its state.

DESCRIPTIONS

The register displays the current state of the modem control lines. Also, four bits also provide an indication in the state of one of the modem status lines. These bits are set to '1' when a change in corresponding line has been detected and they are reset when the register is being read.

UART Receiver Buffer

Address UART_Baseaddress + 0x20

Type read

31	30	29	28	27	26	25	24	23	22	21	20	19	18	17	16
RX_BUF															
15	14	13	12	11	10	9	8	7	6	5	4	3	2	1	0

[31:0] RX_BUF – Receiver Buffer

DESCRIPTIONS

Receiver FIFO output

UART Transmitter Holding Register

Address UART_Baseaddress + 0x20

Type write

31	30	29	28	27	26	25	24	23	22	21	20	19	18	17	16
TX_BUF															
15	14	13	12	11	10	9	8	7	6	5	4	3	2	1	0

[31:0] TX_BUF – Transmitter Buffer

DESCRIPTIONS

Transmit FIFO input

GPIO Register Definitions

GPIO Interrupt Enable Register

Address GPIO_Baseaddress + 0x00

Type write

31	30	29	28	27	26	25	24	23	22	21	20	19	18	17	16
															GPIO interrupt status clear
15	14	13	12	11	10	9	8	7	6	5	4	3	2	1	0
															GPIO interrupt enable

[16] GPIO Interrupt Status Clear- FW can clear GPIO interrupt by writing HIGH to this bit.

[00] GPIO Interrupt Enable - GPIO Interrupt can be enabled by writing HIGH to this bit.

DESCRIPTIONS

GPIO Interrupt Status clear bit can clear the interrupt status bit by writing bit 16 "1".

GPIO Interrupt Status Register

Address GPIO_Baseaddress + 0x00

Type read

31	30	29	28	27	26	25	24	23	22	21	20	19	18	17	16
15	14	13	12	11	10	9	8	7	6	5	4	3	2	1	0
															GPIO interrupt status

[00] GPIO Interrupt Status- GPIO set this bit to HIGH to interrupt FW.

DESCRIPTIONS

GPIO Line Driving Register0

Address GPIO_Baseaddress + 0x30

Type write

31	30	29	28	27	26	25	24	23	22	21	20	19	18	17	16
GPIO Line Driver 31:24								GPIO Line Driver 23:16							
15	14	13	12	11	10	9	8	7	6	5	4	3	2	1	0
GPIO Line Driver 15:8								GPIO Line Driver 7:0							

[31: 24] GPIO Line Driver 31:24 – Output Data from GPIO 31 to 24

[23: 16] GPIO Line Driver 23:16 – Output Data from GPIO 23 to 16

[15: 8] GPIO Line Driver 15:8 – Output Data from GPIO 15 to 8

[7: 0] GPIO Line Driver 7:0 – Output Data from GPIO 7 to 0

DESCRIPTIONS

GPIO Line Driver 31 : 0

GPIO Line Driving Register1

Address GPIO_Baseaddress + 0x34

Type write

31	30	29	28	27	26	25	24	23	22	21	20	19	18	17	16
								GPIO Line Driver 55:48							
15	14	13	12	11	10	9	8	7	6	5	4	3	2	1	0
GPIO Line Driver 47:40								GPIO Line Driver 39:32							

[23: 16] GPIO Line Driver 55:48 – Output Data from GPIO 55 to 48

[15: 8] GPIO Line Driver 47:40 –Output Data from GPIO 47 to 40

[7: 0] GPIO Line Driver 39:32 –Output Data from GPIO 39 to 32

DESCRIPTIONS

GPIO Line Driver 55 : 32

GPIO Line Control Register0

Address GPIO_Baseaddress + 0x40

Type write

31	30	29	28	27	26	25	24	23	22	21	20	19	18	17	16
GPIO Direction Control 31:24								GPIO Direction Control 23:16							
15	14	13	12	11	10	9	8	7	6	5	4	3	2	1	0
GPIO Direction Control 15:8								GPIO Direction Control 7:0							

[31:24] GPIO Direction Control 31:24 – Input and Output Pin Direction Control from GPIO 31 to 24

1 : Output, 0: Input

[23:16] GPIO Direction Control 23:16 – Input and Output Pin Direction Control from GPIO 23 to 16

1 : Output, 0: Input

[15:8] GPIO Direction Control 15:8 – Input and Output Pin Direction Control from GPIO 15 to 8

1 : Output, 0: Input

[7:0] GPIO Direction Control 7:0 – Input and Output Pin Direction Control from GPIO 7 to 0

1 : Output, 0: Input

DESCRIPTIONS

GPIO Line Control Register0 : Input/Output Control 31 : 0

GPIO Line Control Register1

Address GPIO_Baseaddress + 0x44

Type write

31	30	29	28	27	26	25	24	23	22	21	20	19	18	17	16
GPIO Direction Control 55:48								GPIO Direction Control 55:48							
15	14	13	12	11	10	9	8	7	6	5	4	3	2	1	0
GPIO Direction Control 47:40								GPIO Direction Control 39:32							

[23: 16] GPIO Direction Control 55:48 – Input and Output Pin Direction Control from GPIO 55 to 48

1 : Output, 0: Input

[15: 8] GPIO Direction Control 47:40 –Input and Output Pin Direction Control from GPIO 47 to 40

1 : Output, 0: Input

[7: 0] GPIO Direction Control 39:32 –Input and Output Pin Direction Control from GPIO 39 to 32

1 : Output, 0: Input

DESCRIPTIONS

GPIO Line Control Register1 : Input/Output Control 55 : 32

GPIO Line Load Register0

Address GPIO_Baseaddress + 0x20

Type read

31	30	29	28	27	26	25	24	23	22	21	20	19	18	17	16
GPIO Line Load 31:24								GPIO Line Load 23:16							
15	14	13	12	11	10	9	8	7	6	5	4	3	2	1	0
GPIO Line Load 15:8								GPIO Line Load 7:0							

[31: 24] GPIO Line Load 31:24 –Input Pin from GPIO 31 to 24

[23: 16] GPIO Line Load 23:16 –Input Pin from GPIO 23 to 16

[15: 8] GPIO Line Load 15:8 –Input Pin from GPIO 15 to 8

[7: 0] GPIO Line Load 7:0 –Input Pin from GPIO 7 to 0

DESCRIPTIONS

GPIO Line Load 31 : 0

GPIO Line Load Register1

Address GPIO_Baseaddress + 0x24

Type read

31	30	29	28	27	26	25	24	23	22	21	20	19	18	17	16
								GPIO Line Load 55:48							
15	14	13	12	11	10	9	8	7	6	5	4	3	2	1	0
GPIO Line Load 47:40								GPIO Line Load 39:32							

[23: 16] GPIO Line Load 55:48 - Input Data from GPIO 55 to 48

[15: 8] GPIO Line Load 47:40 -Input Data from GPIO 47 to 40

[7: 0] GPIO Line Load 39:32 -Input Data from GPIO 39 to 32

DESCRIPTIONS

GPIO Line Load 55 : 32

Peripheral Timing

This section describes timing restrictions TW2809 peripheral interface ports such as video interface interface, audio interface, and I2C. Timings for other industry standard peripheral such as PCI

and DDR2 are not covered in this data sheet. Customers can refer to related document for details timing information.

Video Interface

TW2809 supports 4 video input ports and four video output ports. Their timing information are covered here.

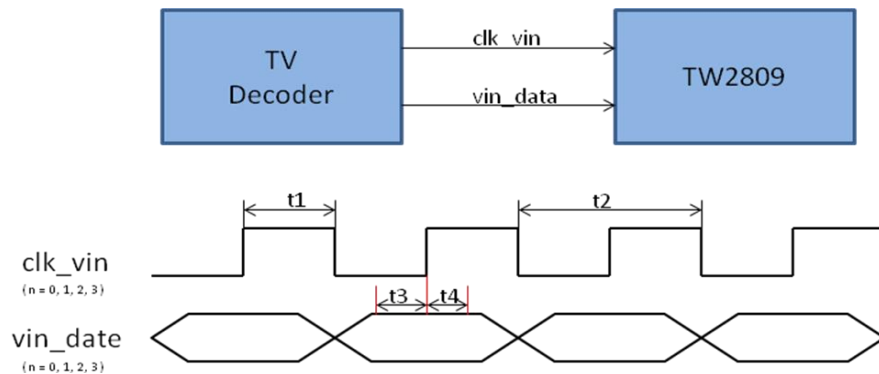

FIGURE 17. VIDEO INPUT PORT TIMING DIAGRAM

PARAMETER	SYMBOL	MIN (Note 1)	TYP	MAX (Note 1)	UNITS
Input Clock Half Period	t1	4.39	4.62 (108Mhz)	19.45	ns
			6.76 (74MHz)		
			9.26 (54MHz)		
			18.52 (27MHz)		
Input Clock Period	t2	8.78	9.25 (108Mhz)	38.8	ns
			13.51 (74MHz)		
			18.51 (54MHz)		
			37.03 (27MHz)		
Input Data Setup Time	t3	3			ns
Input Data Hold Time	t4	1.5			ns

TABLE 3. VIDEO INPUT PORT AC TIMING

NOTE:

1. Compliance to datasheet limits is assured by one or more methods: production test, characterization and/or design.

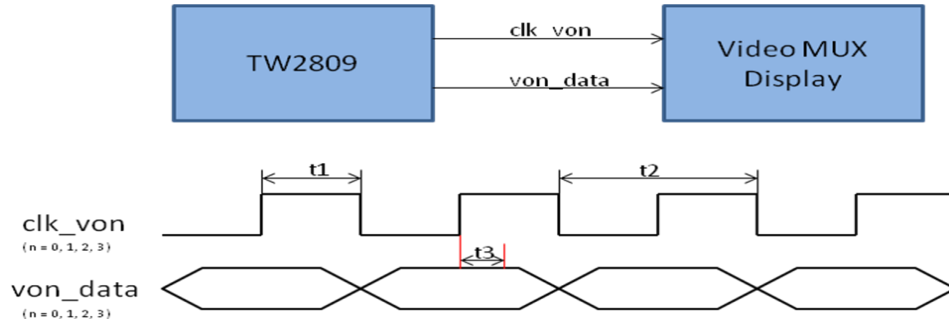

FIGURE 18. VIDEO OUTPUT PORT TIMING DIAGRAM

PARAMETER	SYMBOL	MIN (NOTE1)	TYP	MAX (NOTE1)	UNITS
OUTPUT CLOCK HALF PERIOD	t1	4.39	4.62 (108MHz)	19.45	ns
			6.76 (74MHz)		
			9.26 (54MHz)		
			18.52 (27MHz)		
OUTPUT CLOCK PERIOD	t2	8.78	9.25 (108MHz)	38.8	ns
			13.51 (74MHz)		
			18.51 (54MHz)		
			37.03 (27MHz)		
OUTPUT DATA DELAY	t3	2.6		5.2	ns

TABLE 4. VIDEO OUTPUT PORT AC TIMING

NOTE:

1. Compliance to datasheet limits is assured by one or more methods: production test, characterization and/or design.

Audio Interface

This section describes audio interface port timing.

TW2809 audio interfaces follows industry standard I2S protocol with modifications to support multi-channel audio.

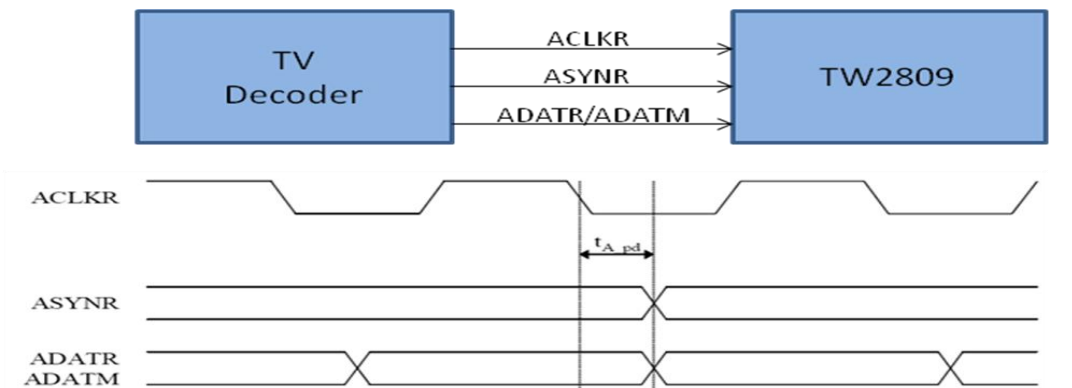

FIGURE 19. AUDIO INPUT PORT TIMING DIAGRAM

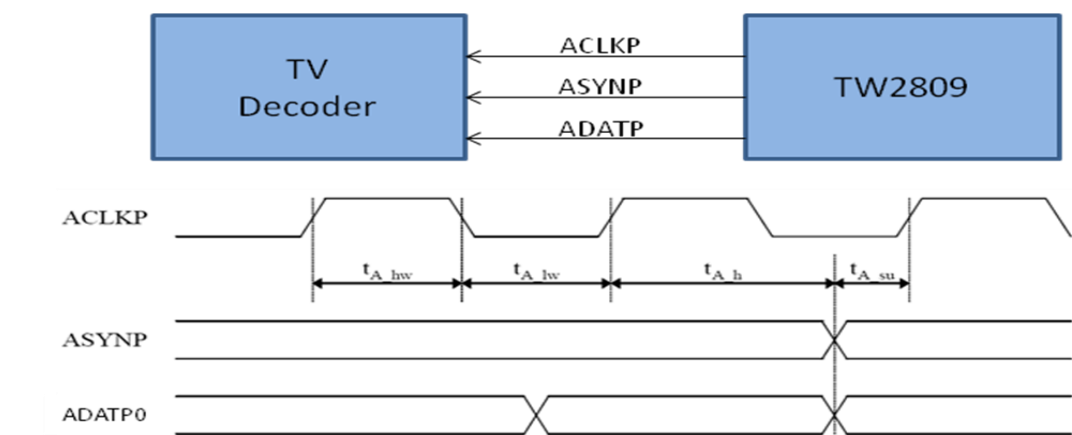

FIGURE 20-1. AUDIO OUTPUT PORT TIMING DIAGRAM

PARAMETER	SYMBOL	MIN	TYP	MAX	UNITS
ASYNR,ADATR,ADATM propagation delay	TA_pd	0.6		2	ns
ACLKP High pulse duration	TA_hw	37			ns
ACLKP Low pulse duration	TA_lw	74			ns
ASYNP, ADATP setup time	TA_su	36			ns
ASYNP, ADATP hold time	TA_h	35			ns

TABLE 5. AUDIO INPUT PORT AC TIMING

NOTE:

1. T_{A_lw} Min value and T_{A_su} Min value are $F_s=48\text{KHz}$ mode only. If $F_s < 48\text{KHz}$, these Min values are more bigger. High period of ACLKR/ACLKP is 27Mhz one clock period.

I2C Interface

This section describes I2C interface timing for TW2809.

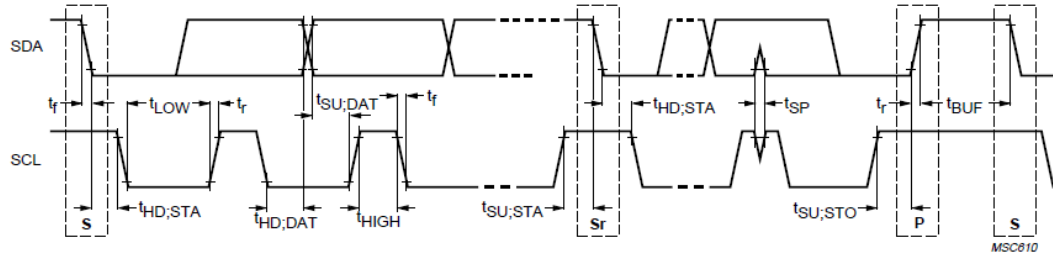

FIGURE 21. I2C PORT TIMING DIAGRAM

TABLE 6. I2C INPUT PORT AC TIMING

PARAMETER	SYMBOL	STANDARD-MODE		FAST-MODE		UNIT
		MIN.	MAX.	MIN.	MAX.	
SCL clock frequency	f_{SCL}	0	100	0	400	kHz
Hold time (repeated) START condition. After this period, the first clock pulse is generated	$t_{HD;STA}$	4.0	–	0.6	–	μ s
LOW period of the SCL clock	t_{LOW}	4.7	–	1.3	–	μ s
HIGH period of the SCL clock	t_{HIGH}	4.0	–	0.6	–	μ s
Set-up time for a repeated START condition	$t_{SU;STA}$	4.7	–	0.6	–	μ s
Data hold time: for CBUS compatible masters (see NOTE, Section 10.1.3) for I ² C-bus devices	$t_{HD;DAT}$	5.0 0	– 3.45	– 0	– 0.9	μ s μ s
Data set-up time	$t_{SU;DAT}$	250	–	100	–	ns
Rise time of both SDA and SCL signals	t_r	–	1000	$20 + 0.1C_b$	300	ns
Fall time of both SDA and SCL signals	t_f	–	300	$20 + 0.1C_b$	300	ns
Set-up time for STOP condition	$t_{SU;STO}$	4.0	–	0.6	–	μ s
Bus free time between a STOP and START condition	t_{BUF}	4.7	–	1.3	–	μ s
Capacitive load for each bus line	C_b	–	400	–	400	pF
Noise margin at the LOW level for each connected device (including hysteresis)	V_{nL}	$0.1V_{DD}$	–	$0.1V_{DD}$	–	V
Noise margin at the HIGH level for each connected device (including hysteresis)	V_{nH}	$0.2V_{DD}$	–	$0.2V_{DD}$	–	V

NOTE:

1. Compliance to datasheet limits is assured by one or more methods: production test, characterization and/or design.

PCI Interface

This section describes PCI interface timing for TW2809.

The PCI of the TW2809 is designed to be satisfied with the protocol and electrical features of the PCI Local Bus Specification, Revision 2.2 32bit/33MHz (66MHz). The PCI interface requires a minimum of 47 pins for a target-only device to handle data and addressing, interface control, arbitration, and system functions.

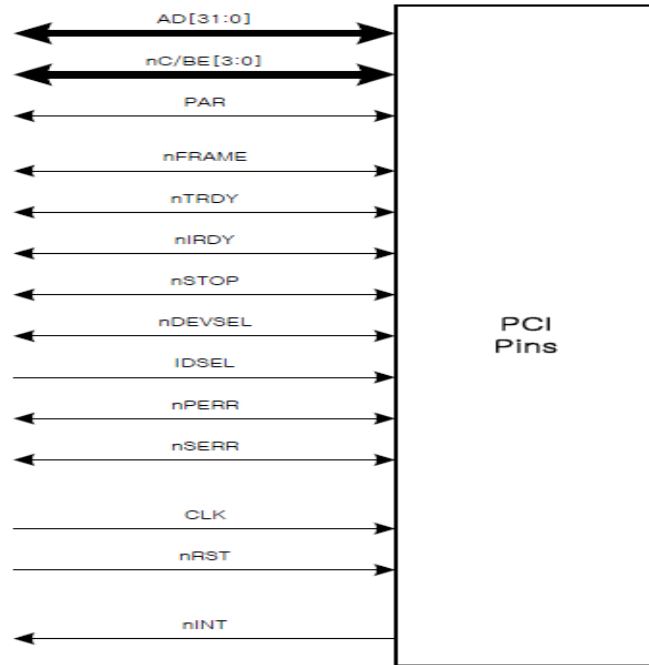

FIGURE 22. PCI PIN LIST

in	<i>Input</i> is a standard input-only signal.
out	<i>Totem Pole Output</i> is a standard active driver.
t/s	<i>Tri-State</i> is a bi-directional, tri-state input/output pin.
s/t/s	<i>Sustained Tri-State</i> is an active low tri-state signal owned and driven by one and only one agent at a time. The agent that drives an s/t/s pin low must drive it high for at least one clock before letting it float. A new agent cannot start driving a s/t/s signal any sooner than one clock after the previous owner tri-states it. A pullup is required to sustain the inactive state until another agent drives it and must be provided by the central resource.
o/d	<i>Open Drain</i> allows multiple devices to share as a wire-OR. A pull-up is required to sustain the inactive state until another agent drives it and must be provided by the central resource.

SYSTEM PINS		
CLK	in	<i>Clock</i> provides timing for all transactions on PCI and is an input to every PCI device. All other PCI signals, except nRST , and nINTD , are sampled on the rising edge of CLK and all other timing parameters are defined with respect to this edge. PCI operates up to 33 MHz and, in general, the minimum frequency is DC (0 Hz).
nRST	in	<i>Reset</i> is used to bring PCI-specific registers, sequencers, and signals to a consistent state. What effect nRST has on a device beyond the PCI sequencer is beyond the scope of this specification, except for reset states of required PCI configuration registers. A device that can wake the system while in a powered down bus state has additional requirements related to nRST . Refer to the <i>PCI Power Management Interface Specification</i> for details. Anytime nRST is asserted, all PCI output signals must be driven to their benign state. In general, this means they must be asynchronously tri-stated. nREQ and nGNT must both be tristated (they cannot be driven low or high during reset). To prevent AD , nC/BE , and PAR signals from floating during reset, the central resource may drive these lines during reset (bus parking) but only to a logic low level; they may not be driven high. nRST may be asynchronous to CLK when asserted or deasserted. Although asynchronous, deassertion is guaranteed to be a clean, bounce-free edge. Except for configuration accesses, only devices that are required to boot the system will respond after reset.
ADDRESS AND DATA PINS		
AD[31:0]	t/s	<i>Address and Data</i> are multiplexed on the same PCI pins. A bus transaction consists of an address phase followed by one or more data phases. PCI supports both read and write bursts. The address phase is the first clock cycle in which nFRAME is asserted. During the address phase, AD[31:0] contain a physical address (32 bits). For I/O, this is a byte address; for configuration and memory, it is a DWORD address. During data phases, AD[07:0] contain the least significant byte (lsb) and AD[31:24] contain the most significant byte (msb). Write data is stable and valid when nIRDY is asserted; read data is stable and valid when nTRDY is asserted. Data is transferred during those clocks where both nIRDY and nTRDY are asserted.
nC/BE[3:0]	t/s	<i>Bus Command and Byte Enables</i> are multiplexed on the same PCI pins. During the address phase of a transaction, nC/BE[3:0] define the bus command. During the data phase, nC/BE[3:0] are used as Byte Enables. The Byte Enables are valid for the entire data phase and determine which byte lanes carry meaningful data. nC/BE[0] applies to byte 0 (lsb) and nC/BE[3] applies to byte 3 (msb).
PAR	t/s	<i>Parity</i> is even3 parity across AD[31:0] and nC/BE[3:0] . Parity generation is required by all PCI agents. PAR is stable and valid one clock after each address phase. For data phases, PAR is stable and valid one clock after either nIRDY is asserted on a write transaction or nTRDY is asserted on a read transaction. Once PAR is valid, it remains valid until one clock after the completion of the current data phase. (PAR has the same timing as AD[31:0] , but it is delayed by one clock.) The master drives PAR for address and write data phases; the target drives PAR for read data phases.
INTERFACE CONTROL PINS		
nFRAME	s/t/s	<i>Cycle Frame</i> is driven by the current master to indicate the beginning and duration of an access. nFRAME is asserted to indicate a bus transaction is beginning. While nFRAME is asserted, data transfers continue. When nFRAME is deasserted, the transaction is in the final data phase or has completed.
nIRDY	s/t/s	<i>Cycle Frame</i> is driven by the current master to indicate the beginning and duration of an access. nFRAME is asserted to indicate a bus transaction is beginning. While nFRAME is asserted, data transfers continue. When nFRAME is deasserted, the transaction is in the final data phase or has completed.
nTRDY	s/t/s	<i>Target Ready</i> indicates the target agent's (selected device's) ability to complete the current data phase of the transaction. nTRDY is used in conjunction with nIRDY . A data phase is completed on any clock both nTRDY and nIRDY are asserted. During a read, nTRDY indicates that valid data is present on AD[31:0] . During a write, it indicates the target is prepared to accept data. Wait cycles are inserted until both nIRDY and nTRDY are asserted together.
nSTOP	s/t/s	<i>Stop</i> indicates the current target is requesting the master to stop the current transaction.

nLOCK	s/t/s	<i>Lock</i> indicates an atomic operation to a bridge that may require multiple transactions to complete. When nLOCK is asserted, non-exclusive transactions may proceed to a bridge that is not currently locked. A grant to start a transaction on PCI does not guarantee control of nLOCK . Control of nLOCK is obtained under its own protocol in conjunction with nGNT . It is possible for different agents to use PCI while a single master retains ownership of nLOCK . Locked transactions may be initiated only by host bridges, PCI-to-PCI bridges, and expansion bus bridges. Refer to Appendix F for details on the requirements of nLOCK .
IDSEL	in	<i>Initialization Device Select</i> is used as a chip select during configuration read and write transactions.
nDEVSEL	s/t/s	<i>Device Select</i> , when actively driven, indicates the driving device has decoded its address as the target of the current access. As an input, nDEVSEL indicates whether any device on the bus has been selected.
ARBITRATION PINS (BUS MASTERS ONLY)		
nREQ	t/s	<i>Request</i> indicates to the arbiter that this agent desires use of the bus. This is a point-to-point signal. Every master has its own nREQ which must be tri-stated while nRST is asserted.
nGNT	t/s	<i>Grant</i> indicates to the agent that access to the bus has been granted. This is a point-to-point signal. Every master has its own nGNT which must be ignored while nRST is asserted.
ERROR REPORTING PINS		
nPERR	s/t/s	<i>Parity Error</i> is only for the reporting of data parity errors during all PCI transactions except a Special Cycle. The nPERR pin is sustained tri-state and must be driven active by the agent receiving data (when enabled) two clocks following the data when a data parity error is detected. The minimum duration of nPERR is one clock for each data phase that a data parity error is detected. (If sequential data phases each have a data parity error, the nPERR signal will be asserted for more than a single clock.) nPERR must be driven high for one clock before being tri-stated as with all sustained tri-state signals.
nSERR	o/d	<i>System Error</i> is for reporting address parity errors, data parity errors on the Special Cycle command, or any other system error where the result will be catastrophic. If an agent does not want a non-maskable interrupt (NMI) to be generated, a different reporting mechanism is required. nSERR is pure open drain and is actively driven for a single PCI clock by the agent reporting the error. The assertion of nSERR is synchronous to the clock and meets the setup and hold times of all bused signals. However, the restoring of nSERR to the deasserted state is accomplished by a weak pullup (same value as used for s/t/s) which is provided by the central resource not by the signaling agent. This pullup may take two to three clock periods to fully restore nSERR . The agent that reports nSERR to the operating system does so anytime nSERR is asserted.
INTERRUPT PINS (OPTIONAL)		
nINT	o/d	<i>Interrupt</i> is used to request an interrupt.

Exactly how the **IDSEL** pin is driven is left to the discretion of the host/memory bridge or system designer. This signal has been designed to allow its connection to one of the upper 21 address lines, which are not otherwise used in a configuration access. However, there is no specified way of determining **IDSEL** from the upper 21 address bits. Therefore, the **IDSEL** pin must be supported by all targets. Devices must not make an internal connection between an AD line and an internal **IDSEL** signal in order to save a pin. The only exception is the host bridge, since it defines how **IDSELs** are mapped. **IDSEL** generation behind a PCI-to-PCI bridge is specified in the PCI-to-PCI Bridge Architecture Specification. How a system generates **IDSEL** is system specific; however, if no other mapping is required, the following example may be used. The **IDSEL** signal associated with Device Number 0 is connected to AD[16], **IDSEL** of Device Number 1 is connected to AD[17], and so forth until **IDSEL** of Device Number 15 is connected to AD[31]. For Device Number 17-31, the host bridge should execute the transaction but not assert any of the AD[31:16] lines but allow the access to be terminated with Master-Abort.

Twenty-one different devices can be uniquely selected for configuration accesses by connecting a different address line to each device and asserting one of the AD[31:11] lines at a time. The issue with connecting one

of the upper 21 AD lines to IDSEL to the appropriate AD line. This does, however, create a very slow slew rate on IDSEL, causing it to be in an invalid logic state most of the time, as shown in Figure 23 with “XXXX” marks.

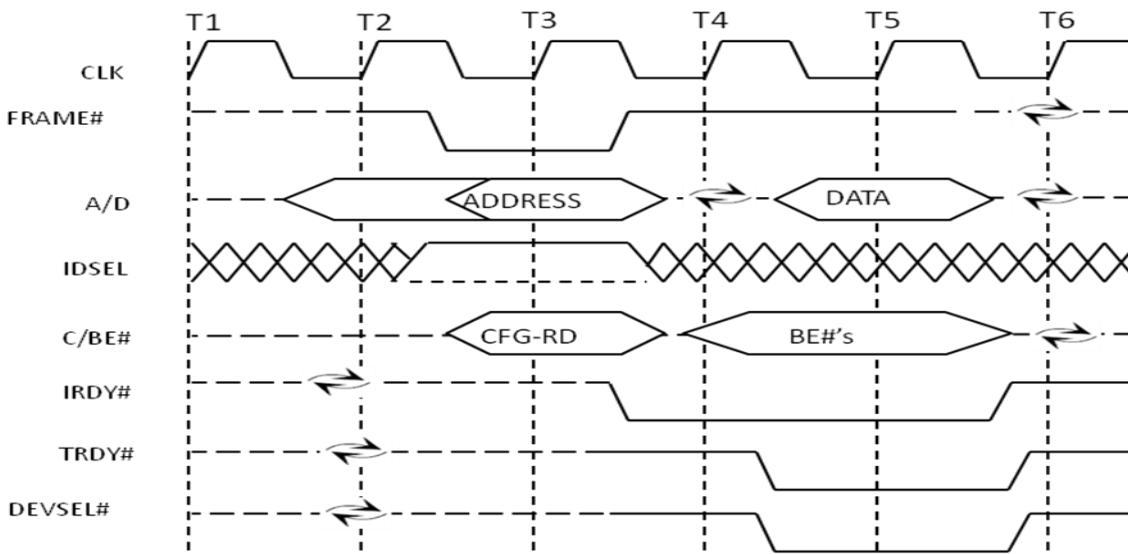

FIGURE 23. CONFIGURATION READ

Figure 24 illustrates a real transaction and starts with an address phase which occurs when nFRAME is asserted for the first time and occurs on clock2. During the address phase, AD[31:0] contain a valid address and nC/BE[3:0] contain a valid bus command.

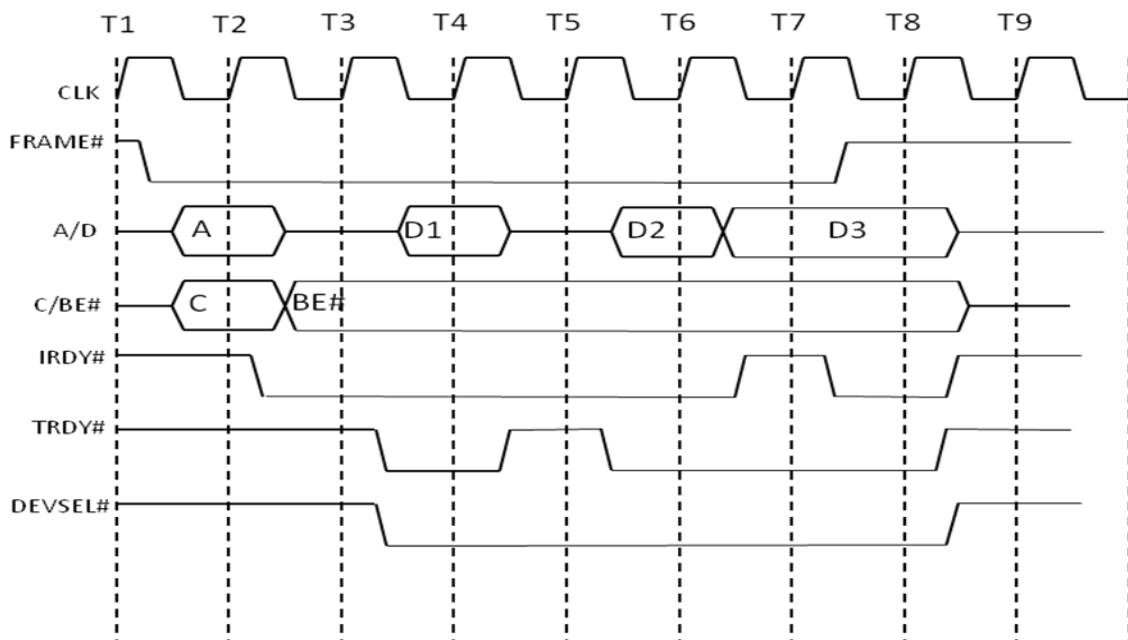

FIGURE 24. BASIC READ OPERATION

The first clock of the first data phase is clock3. During the data phase, nC/BE indicate which byte lanes are involved in the current data phase. A data phase may consist of wait cycles and a data transfer. The nC/BE output buffers must remain enabled (for both read and writes) from the first clock of the data phase through the end of the transaction. This ensures nC/BE are not left floating for long intervals. The nC/BE lines contain valid byte enable information during the entire data phase independent of the state of nIRDY. The nC/BE

lines contain the byte enable information for data phase N+1 on the clock following the completion of the data phase N. This is not shown in Figure 24 because a burst read transaction typically has all byte enables asserted; however, it is shown in Figure 25. Notice on clock 5 in Figure 25, the master inserted a wait state by deasserting nIRDY. However, the byte enables for data phase 3 are valid on clock 5 and remain valid until the data phase completes on clock 8.

The first data phase on a read transaction requires a turnaround-cycle (enforced by the target via nTRDY). In this case, the address is valid on clock 2 and then the master stops driving AD. The earliest the target can provide valid data is clock 4. The target must drive the AD lines following the turnaround cycle when nDEVSEL is asserted. Once enabled, the output buffers must stay enabled through the end of the transaction. (This ensures that the AD lines are not left floating for lone intervals.)

One way for a data phase to complete is when data is transferred, which occurs when both nIRDY and nTRDY are asserted on the same rising clock edge. There are other conditions that complete a data phase. (nTRDY cannot be driven until nDEVSEL is asserted.) When either nIRDY or nTRDY is deasserted, a wait cycle is inserted and no data is transferred. Data is successfully transferred on clocks 4, 6, and 8 and wait cycles are inserted on clock 3, 5, and 7. The first data phase completes in the minimum time for a read transaction. The second data phase is extended on clock 5 because nTRDY is deasserted. The last data phase is extended because nIRDY was deasserted on clock 7.

The master knows at clock 7 that the next data phase is the last. However, because the master is not ready to complete the last transfer (nIRDY is deasserted on clock 7), nFRAME stays asserted. Only when nIRDY is asserted can nFRAME be deasserted as occurs on clock 8, indicating to the target that this is the last data phase of the transaction.

Figure 25 illustrates a write transaction. The transaction starts when nFRAME is asserted for the first time which occurs on clock 2. A write transaction is similar to a read transaction except no turnaround cycle is required following the address phase because the master provides both address and data. Data phases work the same for both read and write transactions.

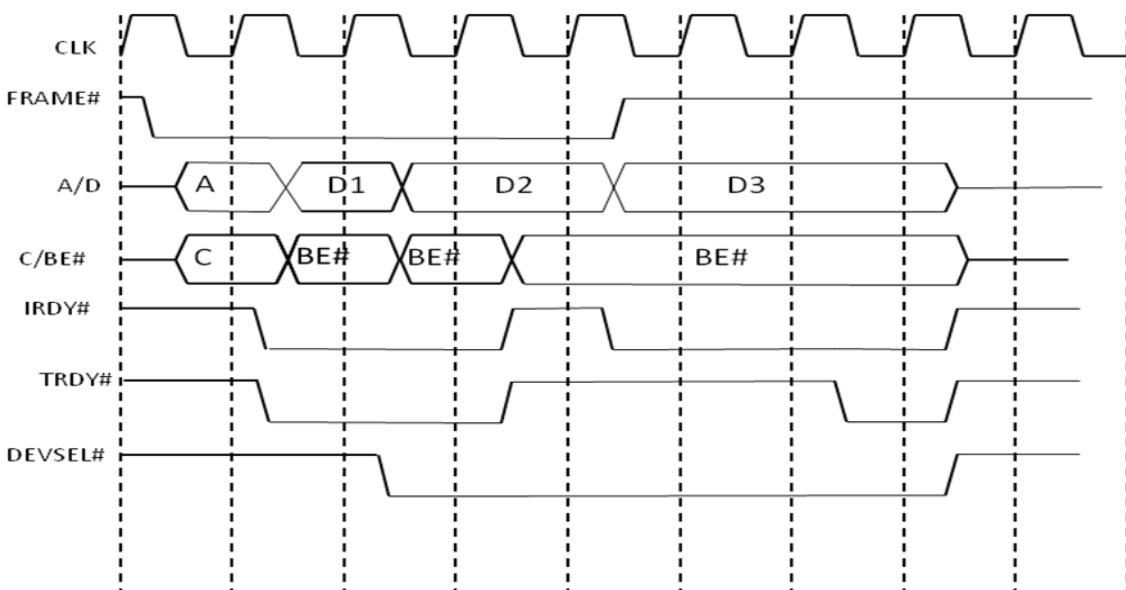

FIGURE 25. BASIC WRITE OPERATION

In Figure 25, the first and second data phases complete with zero wait cycles. However, the third data phase has three wait cycles inserted by the target. Notice both agents insert a wait cycle on clock 5. nIRDY must be asserted when nFRAME is deasserted indicating the last data phase.

The data transfer was delayed by the master on clock 5 because nIRDY was deasserted. The last data phase is signaled by the master on clock 6, but it does not complete until clock 8.

Table 7 shows PCI configuration registers, which is listed up initial values. Device ID, Vendor ID, Subsys ID, Subsys Vendor ID, Class Code, Rev ID, Header Type, Max Lat, Min Gnt and Int Pin of PCI configuration registers can be update by only PCI configuration EEPROM. Command, Status, Latency Timer, Cache Line Size, Memory Base Address, Interrupt Line, Retry Timeout and TRDY Timeout of PCI configuration registers can be update by PCI configuration write as shown as Figure 23. In this case, PCI command needs to be change as PCI configuration write instead of PCI configuration read. In addition, PCI configuration read is used to read PCI configuration registers for checking initial value and updated value.

TABLE 7. PCI CONFIGURATION REGISTERS

31	16	15	0	Offset	Initial Value
Device ID		Vendor ID		00h	2809_1797h
Status		Command		04h	02a0_0007h
Class Code			Revision ID	08h	048000_02h
BIST	Header Type	Latency Timer	Cache line Size	0Ch	00_00_00_00h
Memory Base Address				10h	00_00000_8h(?)
Reserved				14h	
Reserved				18h	
Reserved				1Ch	
Reserved				20h	
Reserved				24h	
Card bus CIS Pointer				28h	0000_0000h
Subsystem ID		Subsystem Vendor ID		2Ch	2809_1719h
Expansion ROM Base Address				30h	0000_0000h
Reserved			Capabilities Pointers	34h	000000_00h
Reserved				38h	
Max_Lat	Min_Gnt	Interrupt Pin	Interrupt Line	3Ch	48_20_01_00h
Reserved		Retry Timeout	TRDY Timeout	40h	0000_80_80h

TABLE 8. CONTENTS OF PCI CONFIGURATION EEPROM

Address	Contents	
00h	Vendor ID	
04h	Device ID	
58h	Subsystem Vendor ID	
5Ch	Subsystem ID	
78h	Interrupt Pin	
7Ch	Max_Lat	Min_Gnt

UART Interface

The UART serial communication parameters comply with EIA-RS-232-C Interface Standard. The frame properties are specified in Figure 26. Every frame starts with the **start bit** (which is always 0), followed by the least significant data bit (indicated with D0). Then the next data bits are succeeding, ending with the most significant bit (indicated with D7).

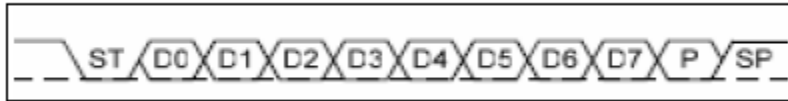

FIGURE 26. FRAME STRUCTURE (ST=START BIT, DN=DATA BITS, P=PARITBIT, SP=STOP BIT)

The parity bit is inserted after the data bits, before the **stop bit** (which is always 1). When a complete frame is transmitted, it can be directly followed by a new frame, or the communication line can be set to an idle (high) state. Each **frame** corresponds to a **single byte of information**.

Each command or query can consist of one or several successive **RxD frames**. The lamp driver will answer accordingly with one or several successive **TxD frames**. Figure 27 shows the communication flow and defines the timing limit for receiving and transmitting **TMAX Command** and **TMAX Response**.

Following timing limits in the communication flow have to be kept:

- if after the time **TMAX Command = 15 ms** a whole command is not transmitted completely to the lamp driver, the command queue is cleared (this is necessary to synchronize the command decoding algorithm with the projector electronics) and the error byte ABh is returned;
- the response will start earliest after having received the first frame of a command and latest after having received the last frame of a command plus a processing time, which can vary between zero and 5 ms. The whole response time is guaranteed to be finished after **TMAX Response = 10 ms**.

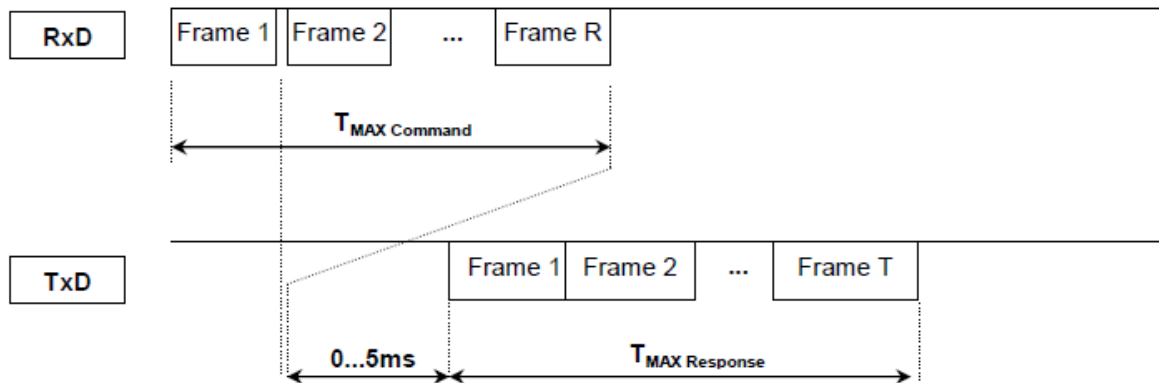

FIGURE 27. COMMUNICATION FLOW CHART

TABLE 9. UART PARAMETER

Frame Parameter	Value	Tolerance
Baud Rate	128000 (max.)	±1%
Number of Start Bits	1	n/a
Number of Data Bits	8	n/a
Number of Stop Bits	1/2	n/a
Parity Bit	Odd/Even/None	n/a

DDR2 Timing

Specification Name		Symbol	Related DRAM spec	Value [ps]	Remarks
CMD-CK	Skew (maximum)	CMD_CLK_skew_max	tIS	680	*1
	Skew (minimum)	CMD_CLK_skew_min	tIH	200	*1
TxDQS-CK	Skew (maximum)	TxDQS_CK_skew_max	tDQSS(max), tDSS	280	*2, *3
	Skew (minimum)	TxDQS_CK_skew_min	tDQSS(min), tDSH	170	*2, *3
TxDQ-DQS	Skew (maximum)	TxDQ_DQS_skew_max	tDS	390	*4
	Skew (minimum)	TxDQ_DQS_skew_min	tDH	380	*4
RxDQ-DQS	Setup	RxDQ_DQS_setup	tDQSQ	-220	*5
	Hold	RxDQ_DQS_hold	tQH	805	*5
Round Trip Time	Delay (maximum)	RTT_delay_max	tDQSCK, tLZ	1000	*6
	Delay (minimum)	RTT_delay_min	tDQSCK, tLZ	0	*6

FIGURE 28. DDR2 TIMING TABLE

*1: CMD-CK timing and circuit diagram

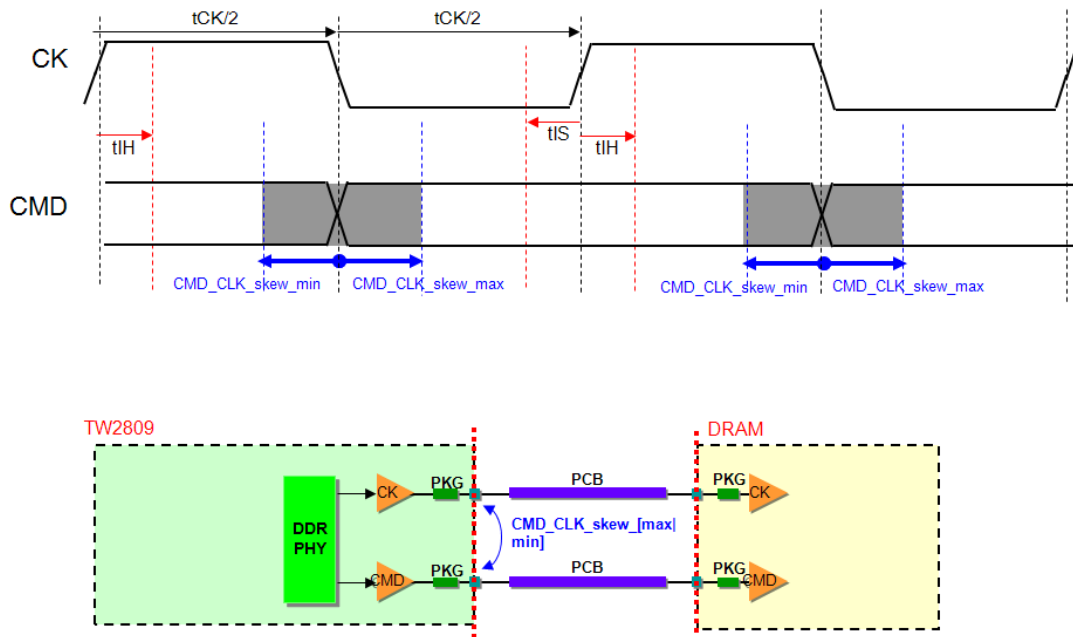

FIGURE 29. CMD-CK TIMING

*2: TxDQS-CK timing and circuit diagram for tDQSS spec

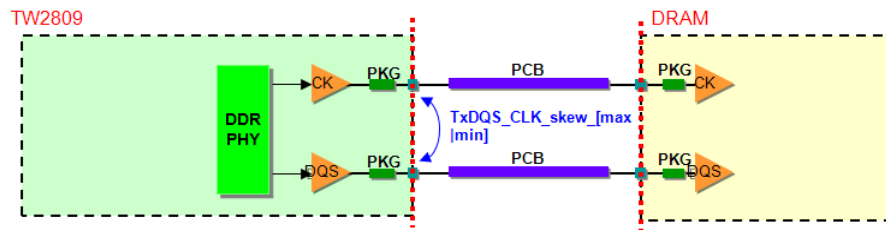
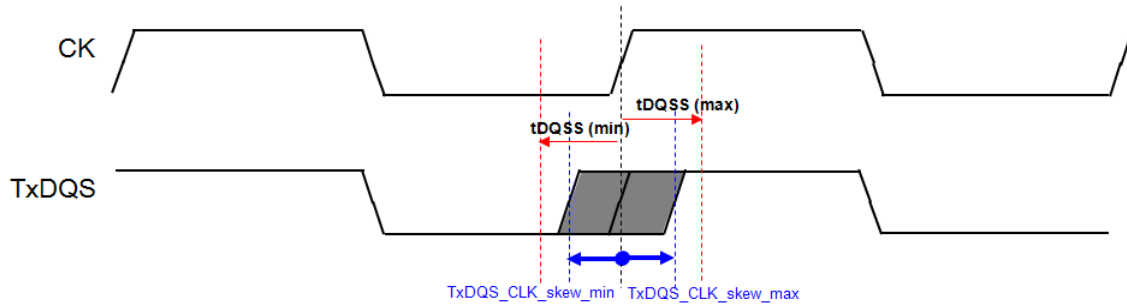

FIGURE 30. TXDQS-CK TIMING FOR TDQSS

*3: TxDQS-CK timing for tDSS/tDSH. The circuitry is the same as the one for tDQSS.

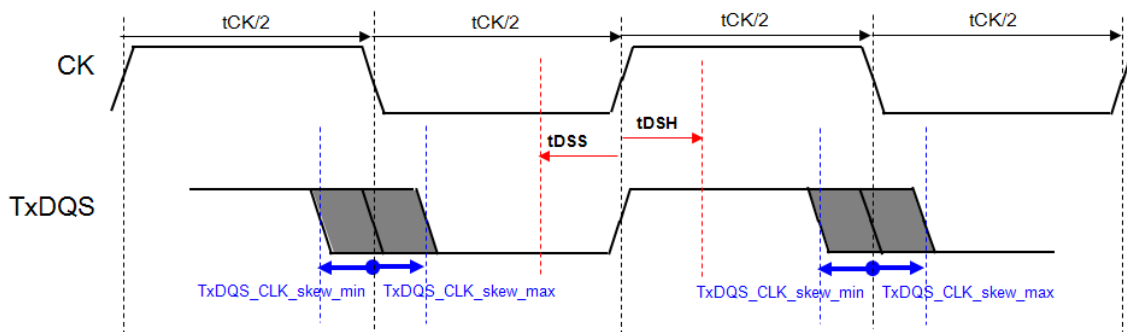

FIGURE 31. TXDQS-CK TIMING FOR TDSS/TDSH

*4: TxDQ-DQS timing and circuit diagram

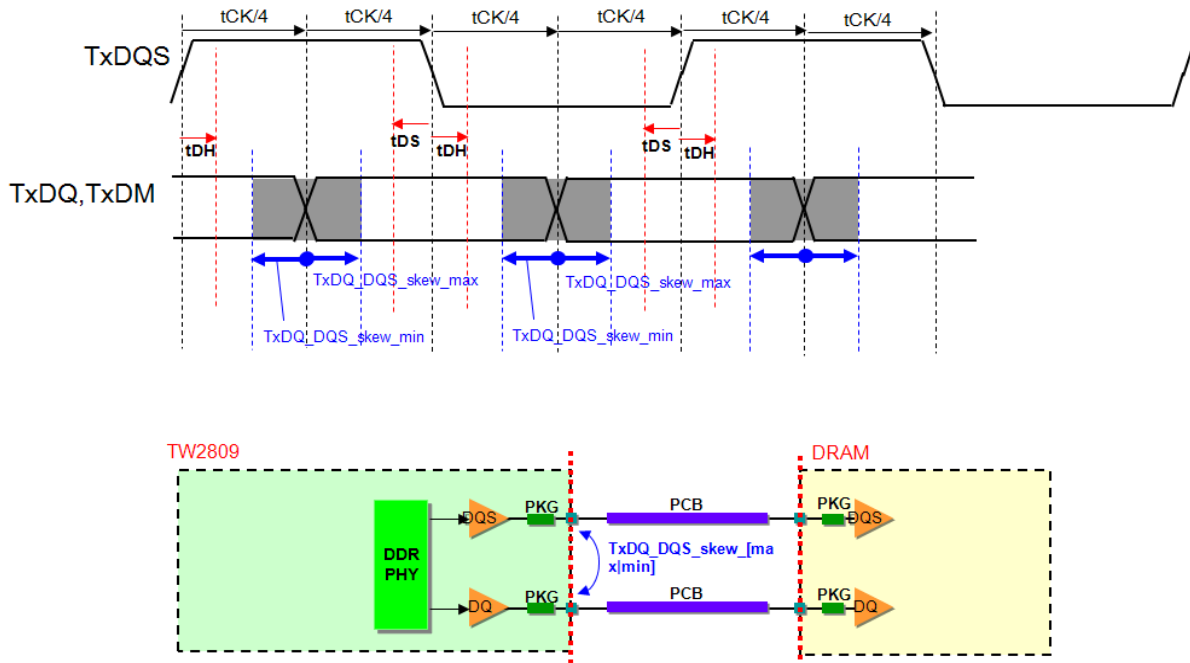

FIGURE 32. TXDQ-DQS TIMING

*5: RxDM-DQS timing and circuit diagram. Please note that rightward arrow of **RxDQ_DQS_setup** is caused by DLL inside DDR PHY which shifts RxDQS by approximately 90 degree independently of PTV variation. Please make sure that your transmission line skew plus tDQSQ is less RxDQ_DQS_setup number.

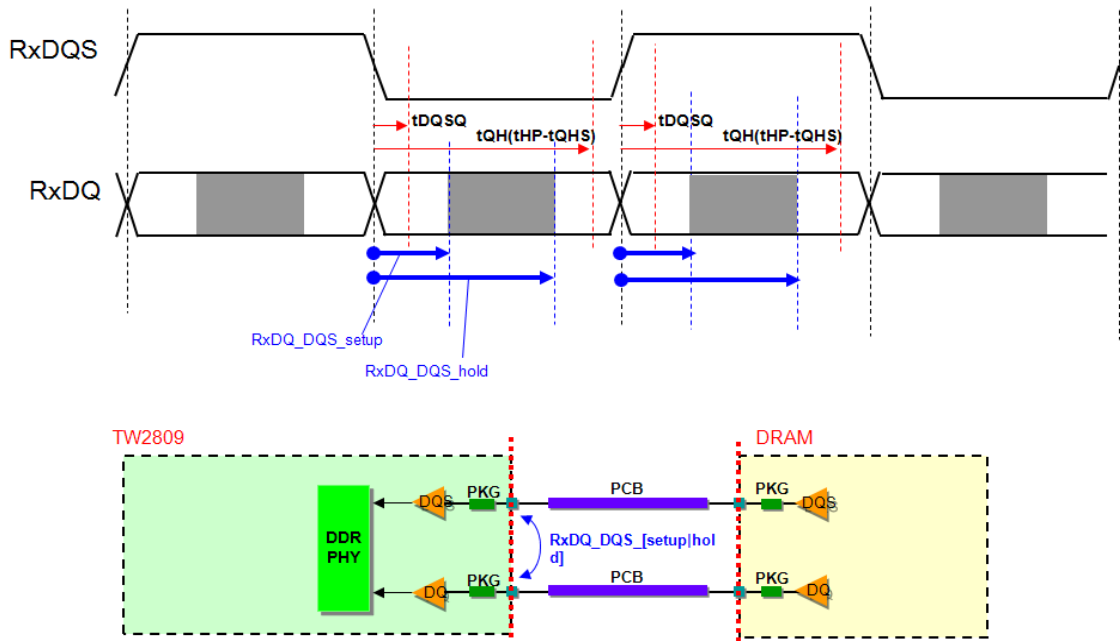

FIGURE 33. RXDQ-DQS TIMING

*6: Round trip path timing and circuit diagram. Please note that the round trip time must contain worst value of t_{DQSCK} or t_{LZ} Specification, that is, minimum number for "minimum round trip time" case, and maximum number for "maximum round trip time" case.

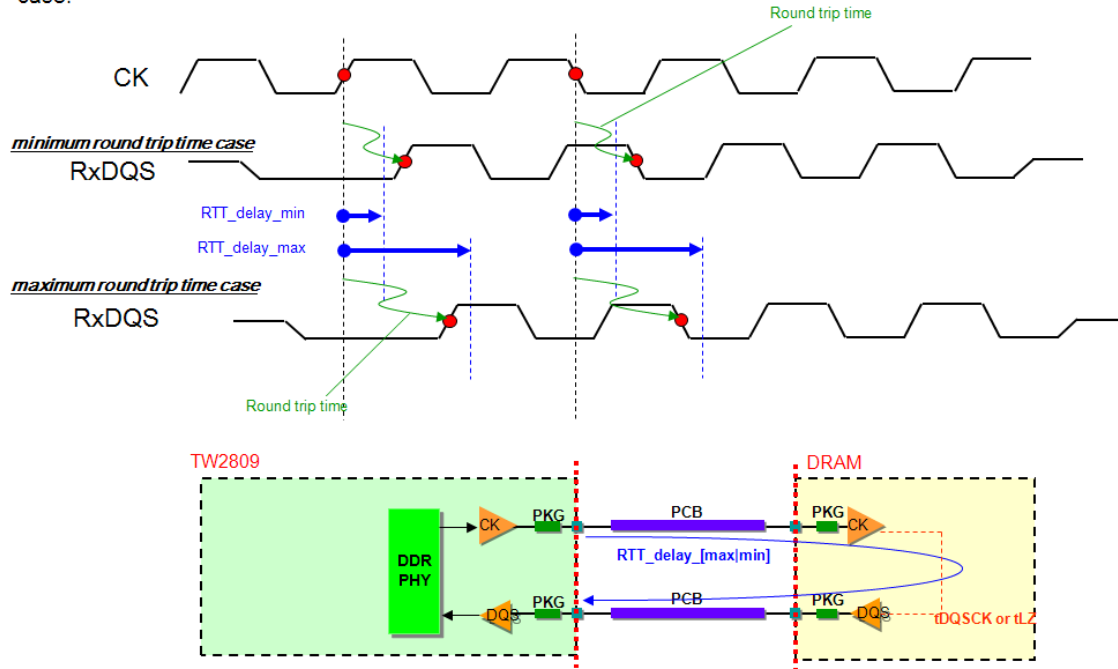

FIGURE 34. ROUND TRIP PATH TIMING

Power Up Sequence

The TW2809 has to follow certain power up sequence to guarantee working. It shows in the diagram below.

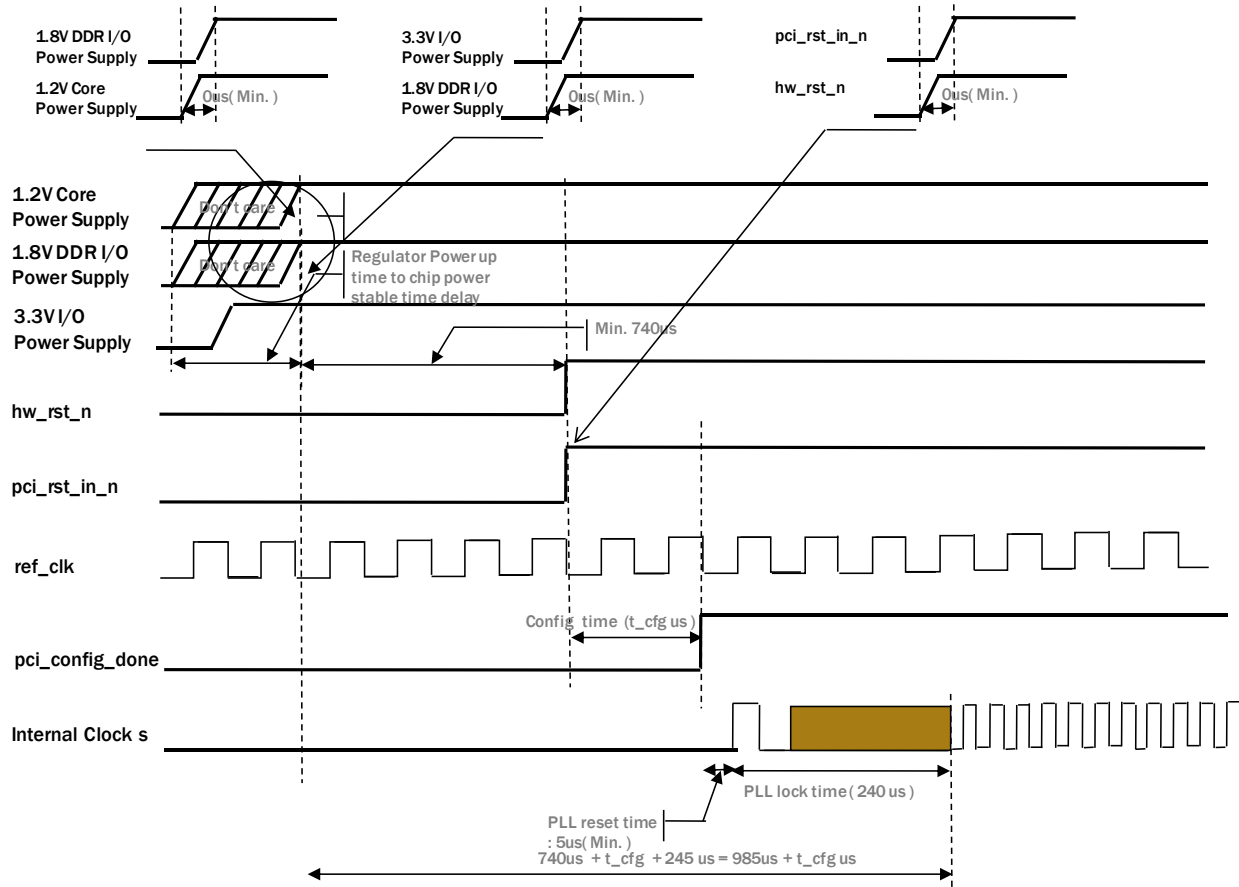

FIGURE 35. TW2809 POWER UP SEQUENCE

Power Off Sequence

The TW2809 has to follow certain power off sequence to guarantee working. It shows in the diagram below.

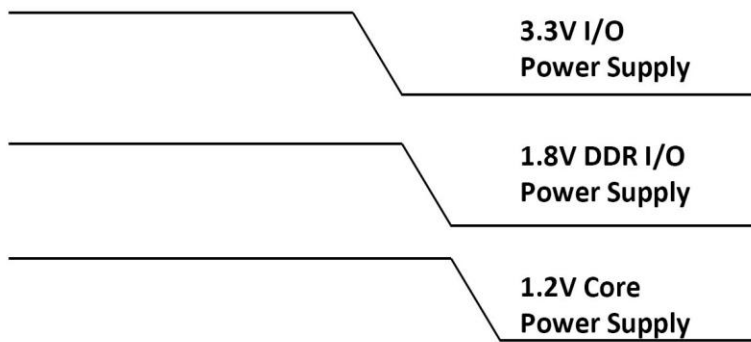

Figure 36. TW2809 POWER OFF SEQUENCE

Electrical Specifications

ABSOLUTE MAXIMUM RATINGS

PARAMETER	SYMBOL	MIN	TYP	MAX	UNITS
Vref	DVDI	-0.5	1.2	1.8	V
PLL AVD	AVDD	-0.5	1.2	1.8	V
DDR AVD 1.8V	SSTL_VDE	-0.5	1.8	2.5	V
VDD 3.3V	DVDE	-0.5	3.3	4.6	V
Voltage on Any Digital Data Pin (See Caution statement)	-	-0.5	-	3.8	V
Voltage on OSC Related Analog Pin	-	-0.5	-	3.8	V
Storage Temperature	T _S	-55	-	125	°C
Junction Temperature	T _J	-40	-	125	°C
Reflow Soldering (≤ 10 Seconds)	T _{PEAK}	-	-	240 - 250	°C

CAUTION: Do not operate at or near the maximum ratings listed for extended periods of time. Exposure to such conditions may adversely impact product reliability and result in failures not covered by warranty.

RECOMMENDED OPERATING CONDITIONS

PARAMETER	SYMBOL	MIN	TYP	MAX	UNITS
Vref	DVDI	1.10	1.2	1.25	V
PLL AVD	AVDD	1.15	1.2	1.25	V
DDR AVD	SSTL_VDE	1.7	1.8	1.9	V
VDD 3.3V	DVDE	3.0	3.3	3.6	V
Ambient Operating Temperature	T _A	0	25	70	°C

SUPPLY CURRENT AND POWER DISSIPATION

PARAMETER	SYMBOL	MIN	TYP	MAX	UNITS
PLL Supply Current (1.2V nom)	I _{DDP}		18.2		mA
SSTL 1.8V Supply Current (1.8V nom)	I _{DDH}		215		mA
Digital Internal Supply Current (1.2V nom)	I _{DDI}		580		mA
Digital I/O Supply Current (3.3V nom)	I _{DDO}		18.87		mA
Total Power Dissipation	P _d		1.16		W

DC CHARACTERISTICS

PARAMETER	SYMBOL	MIN (NOTE 1)	TYP	MAX (NOTE 1)	UNITS
Digital Inputs					
Input High Voltage (TTL)	V_{IH}	2.0	—	$V_{DDE} + 0.3$	V
Input Low Voltage (TTL)	V_{IL}	-0.3	—	0.8	V
Input Leakage Current (@ $V_I = 3.3V$ or $0V$)	I_L	—	—	± 4	μA
Input Capacitance	C_{IN}	—	—	16	pF
Digital Outputs					
Output High Voltage	V_{OH}	$V_{DDE} - 0.2$	—	V_{DDE}	V
Output Low Voltage	V_{OL}	0	—	0.2	V
High Level Output Current (@ $V_{OH} = 2.8V$)	I_{OH}	*1			mA
Low Level Output Current (@ $V_{OL} = 0.2V$)	I_{OL}				mA
Tri-state Output Leakage Current (@ $V_O = 2.5V$ or $0V$)	I_{OZ}	—	—	± 4	μA
Output Capacitance	C_O	—	—	16	pF

INPUT / OUTPUT CAPACITANCE

PARAMETER	SYMBOL	REQUIREMENTS	UNITS
Input Pin	C_{IN}	Max 16	pF
Output Pin	C_{OUT}	Max 16	pF
I/O Pin	$C_{I/O}$	Max 16	pF

NOTES:

1. Compliance to datasheet limits is assured by one or more methods: production test, characterization and/or design.

Package Description

Ball Assignment

	1	2	3	4	5	6	7	8	9	10	11	12	13	14	15	16	17	18	19	20			
A	DVSS	DVSS	pci_ad[0]	pci_ad[1]	pci_ad[3]	pci_ad[6]	DVSS	pci_ad[12]	pci_serr_n	pci_perr_n	DVSS	pci_ad[16]	pci_ad[20]	pci_ad[23]	DVSS	pci_ad[28]	pci_clk_in	pci_inta_n	DVSS	DVSS	A		
B	DVSS	SSTL_VDE	ddr_cke	pci_ad[2]	pci_ad[4]	pci_ad[7]	pci_ad[9]	pci_ad[13]	pci_cbe_n[1]	pci_stop_n	pci_irdy_n	pci_ad[17]	pci_ad[21]	pci_ad[24]	pci_ad[25]	pci_ad[29]	pci_req_n	pci_gnt_n	vo1_data[1]	vo1_data[0]	B		
C	ddr_addr[7]	ddr_addr[10]	ddr_we_n	DVSS	pci_ad[5]	pci_cbe_n[0]	pci_ad[10]	pci_ad[14]	pci_par	pci_trdy_n	pci_cbe_n[2]	pci_ad[18]	pci_ad[22]	pci_cbe_n[3]	pci_ad[26]	pci_ad[30]	pci_rst_in_n	vo1_data[4]	vo1_data[3]	vo1_data[2]	C		
D	ddr_addr[12]	ddr_addr[1]	ddr_ba[2]	DVSS	DVDE	pci_ad[8]	pci_ad[11]	pci_ad[15]	DVDE	pci_devsel_n	pci_frame_n	pci_ad[19]	DVDE	pci_idsel	pci_ad[27]	pci_ad[31]	vo0_data[0]	vo1_data[7]	vo1_data[6]	vo1_data[5]	D		
E	DVSS	ddr_addr[3]	ddr_ba[0]	SSTL_VDE													DVDE	vo0_data[3]	vo0_data[2]	vo0_data[1]	E		
F	ddr_addr[9]	ddr_addr[5]	ddr_ba[1]	SSTL_VDE														vo0_data[6]	vo0_data[5]	vo0_data[4]	clk_vo_ou_t0	F	
G	ddr_dq[1]	ddr_dq[0]	ddr_ras_n	DVSS			DVSS	DVDI	DVDE	DVDI	DVDI	DVDE	DVDI	DVSS				vi3_data[0]	clk_vo	vo0_data[7]	DVSS	G	
H	DVSS	ddr_dq[3]	ddr_dq[2]	DVSS			DVDI	DVSS	DVSS	DVSS	DVSS	DVSS	DVSS	DVDI				vi3_data[4]	vi3_data[3]	vi3_data[2]	vi3_data[1]	H	
J	ddr_dqs[0]	ddr_dm[0]	ddr_dq[4]	SSTL_VDE			SSTL_VDE	DVSS	DVDI	DVSS	DVSS	DVDI	DVSS	DVDE				DVDE	vi3_data[6]	vi3_data[5]	clk_vi3	J	
K	ddr_dqs_n[0]	ddr_dq[6]	ddr_dq[5]	SSTL_VDE			DVDI	DVSS	DVSS	DVSS	DVSS	DVSS	DVSS	DVDI				vi2_data[2]	vi2_data[1]	vi2_data[0]	vi3_data[7]	K	
L	DVSS	ddr_dq[7]	ddr_dq[8]	ddr_ref			SSTL_VDE	DVSS	DVSS	DVSS	DVSS	DVSS	DVSS	DVDI				vi2_data[5]	vi2_data[4]	vi2_data[3]	DVSS	L	
M	ddr_dqs[1]	ddr_dq[9]	ddr_dq[10]	DVSS			DVDI	DVSS	DVDI	DVSS	DVSS	DVDI	DVSS	DVDE				vi1_data[0]	vi2_data[7]	vi2_data[6]	clk_vi2	M	
N	ddr_dqs_n[1]	ddr_dm[1]	ddr_dm[1]	DVSS			DVDI	DVSS	DVSS	DVSS	DVSS	DVSS	DVSS	DVDI				DVDE	vi1_data[3]	vi1_data[2]	vi1_data[1]	N	
P	DVSS	ddr_dq[12]	ddr_dq[13]	DOCDRES			DVSS	DVDI	DVDI	DVDE	DVDI	DVDE	DVDI	DVSS				vi1_data[6]	vi1_data[5]	vi1_data[4]	clk_vi1	P	
R	ddr_clk	ddr_dq[14]	ddr_dq[15]	SSTL_VDE															vi0_data[1]	vi0_data[0]	vi1_data[7]	DVSS	R
T	ddr_clk_n	ddr_addr[11]	ddr_cas_n	SSTL_VDE															vi0_data[4]	vi0_data[3]	vi0_data[2]	clk_vi0	T
U	DVSS	ddr_addr[6]	ddr_addr[2]	DVSS	vo2_data[1]	iddrtst[0]	jtag_sel	DVDE	vo3_data[7]	test_mode[4]	jtag_rtkc	test_mode[0]	DVDE	test_mode[2]	arm_sdi_chip	arm_sec_chip	vo3_data[3]	vo3_data[5]	vo0_data[6]	vo0_data[5]	U		
V	ddr_addr[8]	ddr_addr[4]	ddr_addr[0]	ddr_odt	vo2_data[2]	iddrtst[1]	NC	vo3_data[6]	test_mode[5]	test_mode[3]	jtag_tdo	jtag_tck	test_mode[1]	slave_mode	arm_sdo_chip	arm_bu_clk	ADATM	vo3_data[4]	vo3_data[2]	vo0_data[7]	V		
W	DVSS	SSTL_VDE	ddr_cs_n	vo2_data[7]	vo2_data[3]	iddrtst[2]	clk_vo_ou_t1	i2c_sda	arm_testmode	AVSS	AVSS	jtag_tms	vpd	arm_tm1	arm_trst_t	arm_boot_mode	ADATR	ACLKP	vo3_data[1]	vo3_data[0]	W		
Y	DVSS	DVSS	vo2_data[6]	vo2_data[5]	vo2_data[4]	vo2_data[0]	DVSS	i2c_scl	jtag_trstn	AVDD	AVDD	jtag_tdi	ref_clk	hw_rst_n	arm_tm2	ADATP0	ASYNP	ACLKR	ASYNR	DVSS	Y		

FIGURE 37. TW2809C PIN ASSIGNMENT (TOP VIEW)

Pin Definitions

TABLE 10. PIN DEFINITIONS

BALL NO.	SYMBOL	ATTRIBUTE	DESCRIPTIONS
Y13	ref_clk	Input	Chip reference clock input (54MHz)
Y14	hw_rst_n	Input	Chip reset input (active low)
V14	slave_mode	Input	TW2809C operation mode (Tied to "1")
R1	ddr_clk	Output	DDR differential clocks
T1	ddr_clk_n		
V3	ddr_addr[0]	Output	DDR address bus
D2	ddr_addr[1]		
U3	ddr_addr[2]		
E2	ddr_addr[3]		
V2	ddr_addr[4]		
F2	ddr_addr[5]		
U2	ddr_addr[6]		
C1	ddr_addr[7]		
V1	ddr_addr[8]		
F1	ddr_addr[9]		
C2	ddr_addr[10]		
T2	ddr_addr[11]		
D1	ddr_addr[12]		
E3	ddr_ba[0]	Output	DDR control signals
F3	ddr_ba[1]		
D3	ddr_ba[2]		
B3	ddr_cke		
W3	ddr_cs_n		
G3	ddr_ras_n		
T3	ddr_cas_n		
C3	ddr_we_n		
V4	ddr_odt		
G2	ddr_dq[0]	I/O	DDR data bus
G1	ddr_dq[1]		
H3	ddr_dq[2]		
H2	ddr_dq[3]		
J3	ddr_dq[4]		

BALL NO.	SYMBOL	ATTRIBUTE	DESCRIPTIONS
K3	ddr_dq[5]		
K2	ddr_dq[6]		
L2	ddr_dq[7]		
L3	ddr_dq[8]		
M2	ddr_dq[9]		
M3	ddr_dq[10]		
N2	ddr_dq[11]		
P2	ddr_dq[12]		
P3	ddr_dq[13]		
R2	ddr_dq[14]		
R3	ddr_dq[15]		
J1	ddr_dqs[0]	I/O	DDR differential data strobe
K1	ddr_dqs_n[0]		
M1	ddr_dqs[1]		
N1	ddr_dqs_n[1]		
J2	ddr_dm[0]	Output	DDR data write mask
N3	ddr_dm[1]		
P4	DOCDRES	Output	DDR SSTL_18 special purpose output signal (1.8v)
L4	ddr_ref	Input	DDR SSTL_18 reference voltage (1.8v)
A17	pci_clk_in	Input	PCI input clock (33/66 MHz)
A3	pci_ad[0]	I/O	PCI address and data bus
A4	pci_ad[1]		
B4	pci_ad[2]		
A5	pci_ad[3]		
B5	pci_ad[4]		
C5	pci_ad[5]		
A6	pci_ad[6]		
B6	pci_ad[7]		
D6	pci_ad[8]		
B7	pci_ad[9]		
C7	pci_ad[10]		
D7	pci_ad[11]		
A8	pci_ad[12]		
B8	pci_ad[13]		

BALL NO.	SYMBOL	ATTRIBUTE	DESCRIPTIONS
C8	pci_ad[14]		
D8	pci_ad[15]		
A12	pci_ad[16]		
B12	pci_ad[17]		
C12	pci_ad[18]		
D12	pci_ad[19]		
A13	pci_ad[20]		
B13	pci_ad[21]		
C13	pci_ad[22]		
A14	pci_ad[23]		
B14	pci_ad[24]		
B15	pci_ad[25]		
C15	pci_ad[26]		
D15	pci_ad[27]		
A16	pci_ad[28]		
B16	pci_ad[29]		
C16	pci_ad[30]		
D16	pci_ad[31]		
C6	pci_cbe_n[0]	I/O	PCI bus command and byte enable
B9	pci_cbe_n[1]		
C11	pci_cbe_n[2]		
C14	pci_cbe_n[3]		
C17	pci_rst_in_n	Input	PCI control signals
C9	pci_par	I/O	
D11	pci_frame_n	I/O	
B11	pci_irdy_n	I/O	
C10	pci_trdy_n	I/O	
B10	pci_stop_n	I/O	
D14	pci_idsel	Input	
D10	pci_devsel_n	I/O	
B17	pci_req_n	I/O	
B18	pci_gnt_n	Input	
A10	pci_perr_n	I/O	
A9	pci_serr_n	I/O	

BALL NO.	SYMBOL	ATTRIBUTE	DESCRIPTIONS
A18	pci_inta_n	Output	
G18	clk_vo	Input	VO clock input to generate internal four video output ports clocks
F20	clk_vo_out_0	Output	VO clock output for video output ports 0 and 1
D17	vo0_data[0]	I/O	VO video output port 0 data buas Note: vo0_data[7:0] is pin muxed with GPIO[23:16]
E20	vo0_data[1]		
E19	vo0_data[2]		
E18	vo0_data[3]		
F19	vo0_data[4]		
F18	vo0_data[5]		
F17	vo0_data[6]		
G19	vo0_data[7]		
B20	vo1_data[0]	I/O	VO video output port 1 data buas Note1: vo1_data[7:0] is pin muxed with GPIO[15:8]
B19	vo1_data[1]		
C20	vo1_data[2]		
C19	vo1_data[3]		
C18	vo1_data[4]		
D20	vo1_data[5]		
D19	vo1_data[6]		
D18	vo1_data[7]		
W7	clk_vo_out_1	Output	VO clock output for video output ports 2 and 3
Y6	vo2_data[0]	I/O	VO video output port 2 data buas Note: vo2_data[7:0] is pin muxed with GPIO[7:0]
U5	vo2_data[1]		
V5	vo2_data[2]		
W5	vo2_data[3]		
Y5	vo2_data[4]		
Y4	vo2_data[5]		
Y3	vo2_data[6]		
W4	vo2_data[7]		
W20	vo3_data[0]	I/O	VO video output port 3 data buas Note1: vo3_data[7:0] is pin muxed with
W19	vo3_data[1]		
V19	vo3_data[2]		

BALL NO.	SYMBOL	ATTRIBUTE	DESCRIPTIONS
U17	vo3_data[3]		GPIO[55:48]
V18	vo3_data[4]		
U18	vo3_data[5]		
V8	vo3_data[6]		
U9	vo3_data[7]		
T20	clk_vi0	Input	VI video input port 0 clock input
R18	vi0_data[0]	Input	VI video input port 0 data bus
R17	vi0_data[1]		
T19	vi0_data[2]		
T18	vi0_data[3]		
T17	vi0_data[4]		
U20	vi0_data[5]		
U19	vi0_data[6]		
V20	vi0_data[7]		
P20	clk_vi1		
M17	vi1_data[0]	I/O	VI video input port 2 data bus Note: vi1_data[7:0] is pin muxed with GPIO[47:40]
N20	vi1_data[1]		
N19	vi1_data[2]		
N18	vi1_data[3]		
P19	vi1_data[4]		
P18	vi1_data[5]		
P17	vi1_data[6]		
R19	vi1_data[7]		
M20	clk_vi2	Input	VI video input port 2 clock input
K19	vi2_data[0]	I/O	VI video input port 2 data bus Note: vi2_data[7:0] is pin muxed with GPIO[39:32]
K18	vi2_data[1]		
K17	vi2_data[2]		
L19	vi2_data[3]		
L18	vi2_data[4]		
L17	vi2_data[5]		
M19	vi2_data[6]		
M18	vi2_data[7]		
J20	clk_vi3	Input	VI video input port 3 clock input

BALL NO.	SYMBOL	ATTRIBUTE	DESCRIPTIONS
G17	vi3_data[0]	I/O	VI video input port 3 data bus Note1: vi3_data[7:0] is pin muxed with GPIO[31:24] Note2: vi3_data[0] is pin muxed with UART0_Rx Note3: vi3_data[1] is pin muxed with UART0_Tx Note4: vi3_data[2] is pin muxed with UART1_Rx Note5: vi3_data[3] is pin muxed with UART1_Tx
H20	vi3_data[1]		
H19	vi3_data[2]		
H18	vi3_data[3]		
H17	vi3_data[4]		
J19	vi3_data[5]		
J18	vi3_data[6]		
K20	vi3_data[7]		
W18	ACLKP	I/O	AUDIO playback port bit clock, word select, and serial data
Y17	ASYNP		
Y16	ADATP0		
Y18	ACLKR	Input	AUDIO record port bit clock, word select, and serial data
Y19	ASYNR		
W17	ADATR		
V17	ADATM	Input	PLL test pin (Tied to ground "0")
V7	NC		Not connected
W16	arm_boot_mode	Input	ARM926 IP test pins (Tied to ground "0")
W9	arm_tstmode		
W14	arm_tm1		
Y15	arm_tm2		
W15	arm_trst_t		
V16	arm_bu_clk		
U16	arm_se_chip		
U15	arm_sdi_chip		
V15	arm_sdo_chip		
W13	vpd	Input	All DDR Phy IP test pins (Tied to ground "0")
U6	iddrttest[0]		
V6	iddrttest[1]		
W6	iddrttest[2]		
U12	test_mode[0]	Input	All Global test mode pins (Tied to ground "0")
V13	test_mode[1]		

BALL NO.	SYMBOL	ATTRIBUTE	DESCRIPTIONS
U14	test_mode[2]		
V10	test_mode[3]		
U10	test_mode[4]		
V9	test_mode[5]		
V12	jtag_tck	Input	JTAG test pins. All 5 input pins should be tied to LOW for normal operation.
Y9	jtag_trstn	Input	
Y12	jtag_tdi	Input	
U7	jtag_sel	Input	
W12	jtag_tms	Input	
V11	jtag_tdo	Output	
U11	jtag_rtck	Output	
Y8	i2c_scl	I/O	
W8	i2c_sda	I/O	
Y10,Y11	AVDD	1.2V	Power of analog PLL
W10,W11	AVSS	-	Ground of analog PLL
G8,G10,G11,G13,H7, H14,J9,J12,K7,K14, L14,M7,M9,M12,N7, N14,P8,P9,P11,P13	DVDI	1.2V	Power of core logic
B2,E4,F4,J4,J7, K4,L7,R4,T4,W2	SSTL_VDE	1.8V	Power of the DDR I/O
D5,D9,D13,E17,G9, G12,J14,J17,M14, N17,P10,P12,U8,U13	DVDE	3.3V	Power of the external I/O
A1,A2,A7,A11,A15, A19,A20,B1,C4,D4, E1,G4,G7,G14,G20, H1,H4,H8,H9,H10, H11,H12,H13,J8, J10,J11,J13,K8,K9, K10,K11,K12,K13,	DVSS	-	Ground

BALL NO.	SYMBOL	ATTRIBUTE	DESCRIPTIONS
L1,L8,L9,L10,L11, L12,L13,L20,M4, M8,M10,M11,M13, N4,N8,N9,N10,N11, N12,N13,P1,P7,P14, R20,U1,U4,W1,Y1, Y2,Y7,Y20	DVSS		

About

Intersil

Intersil Corporation is a leading provider of innovative power management and precision analog solutions. The company's products address some of the largest markets within the industrial and infrastructure, mobile computing and high-end consumer markets.

For the most updated datasheet, application notes, related documentation and related parts, please see the respective product information page found at www.intersil.com.

You may report errors or suggestions for improving this datasheet by visiting www.intersil.com/ask.

Reliability reports are also available from our website at www.intersil.com/support

Mechanical Specifications

320-pin plastic PBGA
(BGA-320P-M06)

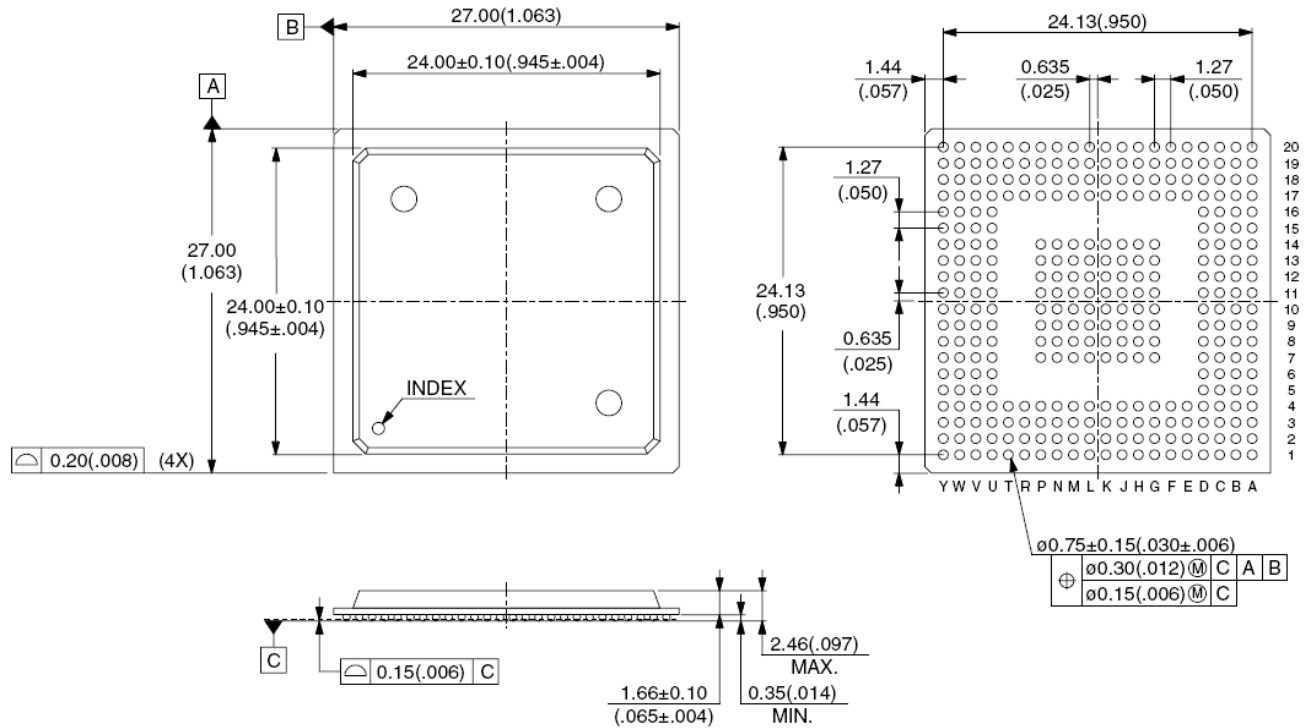

FIGURE 38. MECHANICAL SPECIFICATIONS (BOTTOM VIEW)

© Copyright Intersil Americas LLC 2011-2014. All Rights Reserved.

All trademarks and registered trademarks are the property of their respective owners.

For additional products, see www.intersil.com/product_tree

Intersil products are manufactured, assembled and tested utilizing ISO9001 quality systems as noted in the quality certifications found at <http://www.intersil.com/en/support/qualandreliability.html>

Intersil products are sold by description only. Intersil may modify the circuit design and/or specifications of products at any time without notice, provided that such modification does not, in Intersil's sole judgment, affect the form, fit or function of the product. Accordingly, the reader is cautioned to verify that datasheets are current before placing orders. Information furnished by Intersil is believed to be accurate and reliable. However, no responsibility is assumed by Intersil or its subsidiaries for its use; nor for any infringements of patents or other rights of third parties which may result from its use. No license is granted by implication or otherwise under any patent or patent rights of Intersil or its subsidiaries.

For information regarding Intersil Corporation and its products, see <http://www.intersil.com>