

Dual IGBTMOD™ NX-Series Module 400 Amperes/600 Volts

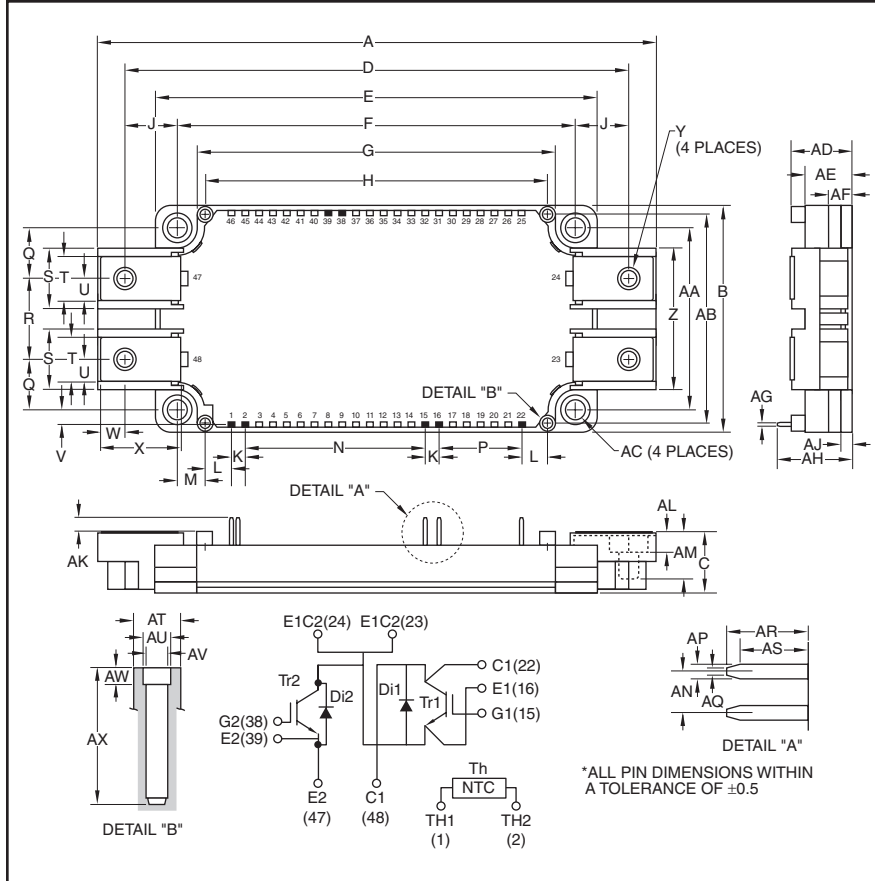

Outline Drawing and Circuit Diagram

Dimensions	Inches	Millimeters
A	5.98	152.0
B	2.44	62.0
C	0.67	17.0
D	5.39	137.0
E	4.79	121.7
F	4.33±0.02	110.0±0.5
G	3.89	99.0
H	3.72	94.5
J	0.53	13.5
K	0.15	3.8
L	0.28	7.25
M	0.30	7.75
N	1.95	49.54
P	0.9	22.86
Q	0.55	14.0
R	0.87	22.0
S	0.67	17.0
T	0.48	12.0
U	0.24	6.0
V	0.16	4.2
W	0.37	6.5
X	0.83	21.14
Y	M6	M6

Dimensions	Inches	Millimeters
Z	1.53	39.0
AA	1.97±0.02	50.0±0.5
AB	2.26	57.5
AC	0.22 Dia.	5.5 Dia.
AD	0.67+0.04/-0.02	17.0+1.0/-0.5
AE	0.51	13.0
AF	0.27	7.0
AG	0.03	0.8
AH	0.81	20.5
AJ	0.12	3.0
AK	0.14	3.5
AL	0.21	5.4
AM	0.49	12.5
AN	0.15	3.81
AP	0.05	1.15
AQ	0.025	0.65
AR	0.29	7.4
AS	0.24	6.2
AT	0.17 Dia.	4.3 Dia.
AU	0.10 Dia.	2.5 Dia.
AV	0.08 Dia.	2.1 Dia.
AW	0.06	1.5
AX	0.49	12.5

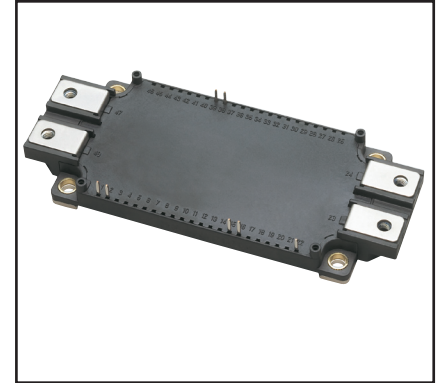

Description:

Powerex IGBTMOD™ Modules are designed for use in switching applications. Each module consists of two IGBT Transistors in a half-bridge configuration with each transistor having a reverse-connected super-fast recovery free-wheel diode. All components and interconnects are isolated from the heat sinking baseplate, offering simplified system assembly and thermal management.

Features:

- AISiC Baseplate
- Low Drive Power
- Low $V_{CE(sat)}$
- Discrete Super-Fast Recovery Free-Wheel Diode
- Isolated Baseplate for Easy Heat Sinking

Applications:

- AC Motor Control
- Motion/Servo Control
- Photovoltaic/Fuel Cell

QID0640020
Dual IGBTMOD™ NX-Series Module
 400 Amperes/600 Volts

Absolute Maximum Ratings, $T_j = 25^\circ\text{C}$ unless otherwise specified

Characteristics	Symbol	QID0640020	Units
Power Device Junction Temperature	T_j	-40 to 150	$^\circ\text{C}$
Storage Temperature	T_{stg}	-55 to 130	$^\circ\text{C}$
Mounting Torque, M5 Mounting Screws	—	31	in-lb
Mounting Torque, M6 Main Terminal Screws	—	40	in-lb
Module Weight (Typical)	—	220	Grams
Baseplate Flatness, On Centerline X, Y (See Below)	—	$\pm 0 \sim +100$	μm
Isolation Voltage, AC 1 minute, 60Hz Sinusoidal	V_{ISO}	2500	Volts

Inverter Sector

Collector-Emitter Voltage (G-E Short)	V_{CES}	600	Volts
Gate-Emitter Voltage (C-E Short)	V_{GES}	± 20	Volts
Collector Current ($T_C = 60^\circ\text{C}$)*1	I_C	400	Amperes
Peak Collector Current (Pulse)*3	I_{CM}	800	Amperes
Emitter Current ($T_C = 25^\circ\text{C}$)*1*4	I_E^{*2}	400	Amperes
Peak Emitter Current (Pulse)*3	I_{EM}^{*2}	800	Amperes
Maximum Collector Dissipation ($T_C = 25^\circ\text{C}$)*1*4	P_C	1115	Watts

*1 Case temperature (T_C) and heatsink temperature (T_f) are defined on the surface of the baseplate and heatsink at just under the chip.

*2 I_E , I_{EM} , V_{EC} , t_{rr} and Q_{rr} represent ratings and characteristics of the anti-parallel, emitter-to-collector free-wheel diode (FWDi).

*3 Pulse width and repetition rate should be such that device junction temperature (T_j) does not exceed $T_{j(max)}$ rating.

*4 Junction temperature (T_j) should not increase beyond $T_{j(max)}$ rating.

BASEPLATE FLATNESS MEASUREMENT POINT

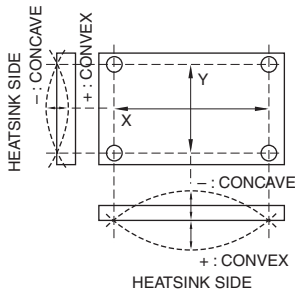

CHIP LOCATION (TOP VIEW)

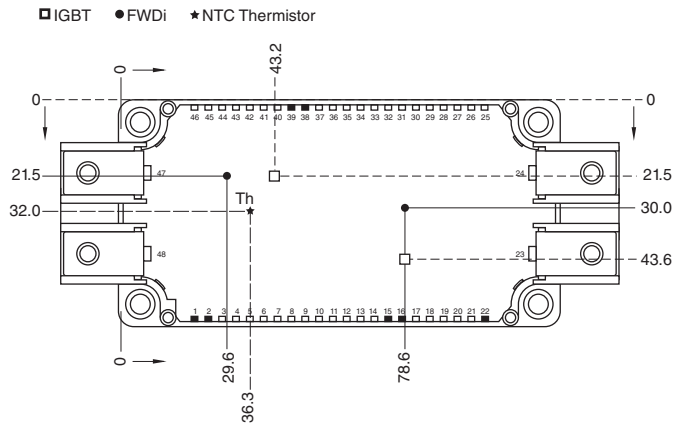

Dimensions in mm (Tolerance: $\pm 1\text{mm}$)

QID0640020

Dual IGBTMOD™ NX-Series Module

400 Amperes/600 Volts

Electrical and Mechanical Characteristics, $T_j = 25^\circ\text{C}$ unless otherwise specified

Inverter Sector

Characteristics	Symbol	Test Conditions	Min.	Typ.	Max.	Units	
Collector Cutoff Current	I_{CES}	$V_{CE} = V_{CES}, V_{GE} = 0V$	—	—	1.0	mA	
Gate-Emitter Threshold Voltage	$V_{GE(th)}$	$I_C = 40mA, V_{CE} = 10V$	5	6	7	Volts	
Gate Leakage Current	I_{GES}	$V_{GE} = V_{GES}, V_{CE} = 0V$	—	—	0.5	μA	
Collector-Emitter Saturation Voltage	$V_{CE(sat)}$	$I_C = 400A, V_{GE} = 15V, T_j = 25^\circ\text{C}^{*5}$	—	1.7	2.1	Volts	
		$I_C = 400A, V_{GE} = 15V, T_j = 125^\circ\text{C}^{*5}$	—	1.9	—	Volts	
		$I_C = 400A, V_{GE} = 15V, \text{Chip}$	—	1.6	—	Volts	
Input Capacitance	C_{ies}		—	—	50.0	nF	
Output Capacitance	C_{oes}	$V_{CE} = 10V, V_{GE} = 0V$	—	—	5.3	nF	
Reverse Transfer Capacitance	C_{res}		—	—	1.6	nF	
Total Gate Charge	Q_G	$V_{CC} = 300V, I_C = 400A, V_{GE} = 15V$	—	1100	—	nC	
Inductive	Turn-on Delay Time	$t_{d(on)}$	—	—	200	ns	
Load	Turn-on Rise Time	t_r	$V_{CC} = 300V, I_C = 400A,$	—	—	200	ns
Switch	Turn-off Delay Time	$t_{d(off)}$	$V_{GE} = \pm 15V,$	—	—	400	ns
Time	Turn-off Fall Time	t_f	$R_G = 3.6\Omega, I_E = 400A,$	—	—	600	ns
Reverse Recovery Time	t_{rr}^{*2}	Inductive Load Switching Operation	—	—	200	ns	
Reverse Recovery Charge	Q_{rr}^{*2}		—	11	—	μC	
Emitter-Collector Voltage	V_{EC}^{*2}	$I_E = 400A, V_{GE} = 0V^{*5}$	—	2.0	2.8	Volts	
		$I_E = 400A, V_{GE} = 0V^{*5}$	—	1.9	—	Volts	

Thermal and Mechanical Characteristics, $T_j = 25^\circ\text{C}$ unless otherwise specified

Characteristics	Symbol	Test Conditions	Min.	Typ.	Max.	Units
Module Lead Resistance	R_{lead}	Main Terminals-Chip (Per Switch)	—	1.1	—	m Ω
Thermal Resistance, Junction to Case**	$R_{th(j-c)Q}$	Per IGBT ^{*1}	—	—	0.112	$^\circ\text{C/W}$
Thermal Resistance, Junction to Case**	$R_{th(j-c)D}$	Per FWDI ^{*1}	—	—	0.192	$^\circ\text{C/W}$
Contact Thermal Resistance**	$R_{th(c-f)}$	Case to Heatsink (Per 1 Module)	—	0.015	—	$^\circ\text{C/W}$
		Thermal Grease Applied ^{*1*7}	—	—	—	—
Internal Gate Resistance	R_{Gint}	$T_C = 25^\circ\text{C}$	—	0	—	Ω
External Gate Resistance	R_G		1.6	—	16	Ω

NTC Thermistor Sector, $T_j = 25^\circ\text{C}$ unless otherwise specified

Characteristics	Symbol	Test Conditions	Min.	Typ.	Max.	Units
Zero Power Resistance	R	$T_C = 25^\circ\text{C}^{*1}$	4.85	5.00	5.15	k Ω
Deviation of Resistance	$\Delta R/R$	$T_C = 100^\circ\text{C}, R_{100} = 493\Omega^{*1}$	-7.3	—	+7.8	%
B Constant	$B_{(25/50)}$	$B = (\ln R_1 - \ln R_2) / (1/T_1 - 1/T_2)^{*6}$	—	3375	—	K
Power Dissipation	P_{25}	$T_C = 25^\circ\text{C}^{*1}$	—	—	10	mW

**Thermal resistance values are per 1 element.

*1 Case temperature (T_C) and heatsink temperature (T_f) are defined on the surface of the baseplate and heatsink at just under the chip.

*2 $I_E, I_{EM}, V_{EC}, t_{rr}$ and Q_{rr} represent ratings and characteristics of the anti-parallel, emitter-to-collector free-wheel diode (FWDI).

*5 Pulse width and repetition rate should be such as to cause negligible temperature rise.

*6 R_1 : Resistance at Absolute Temperature $T_1(K)$, R_2 : Resistance at Absolute Temperature $T_2(K)$, $T(K) = T(^\circ\text{C}) + 273.15$

*7 Typical value is measured by using thermally conductive grease of $\lambda = 0.9 \text{ [W/(m} \cdot \text{K)]}$.



QID0640020
Dual IGBTMOD™ NX-Series Module
 400 Amperes/600 Volts

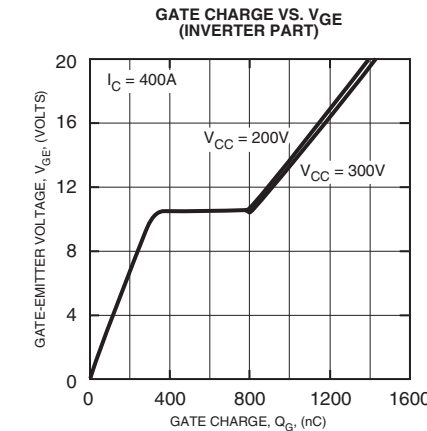
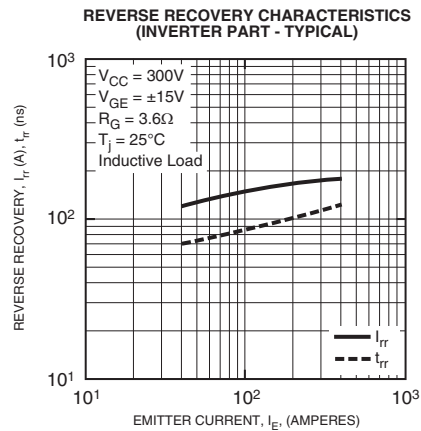
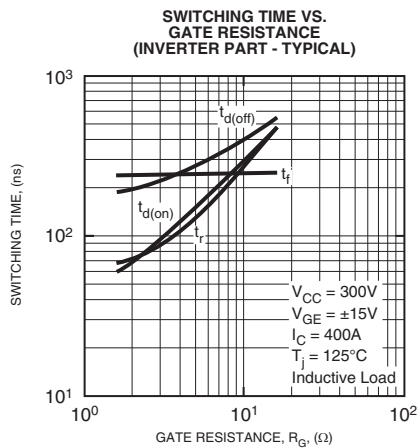
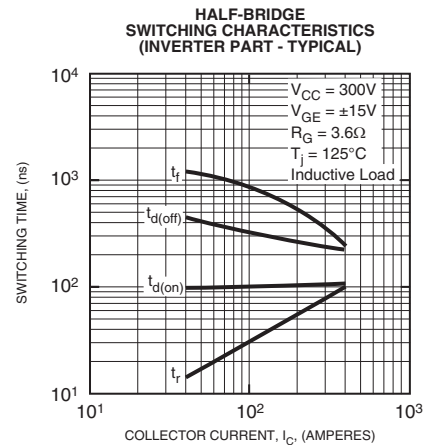
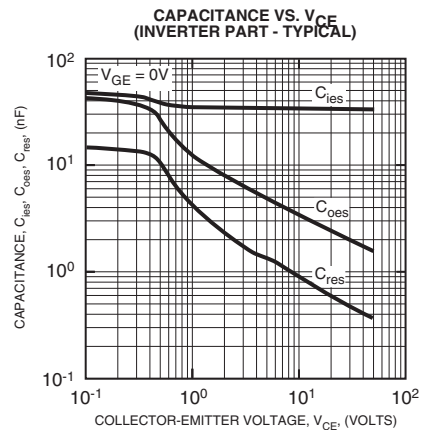
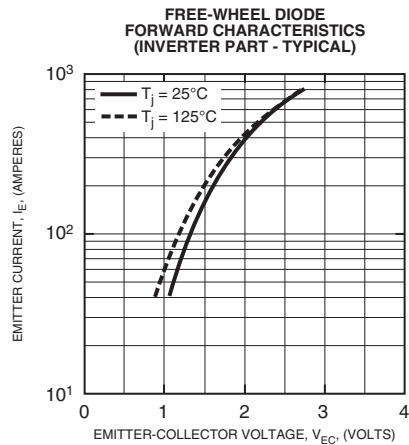
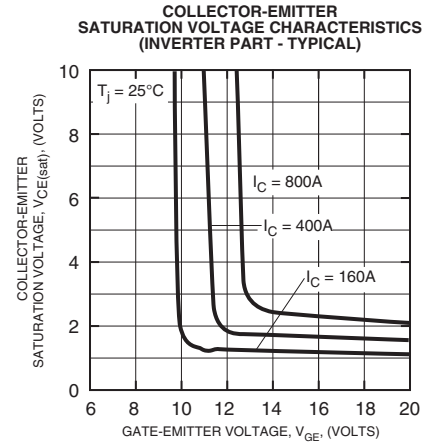
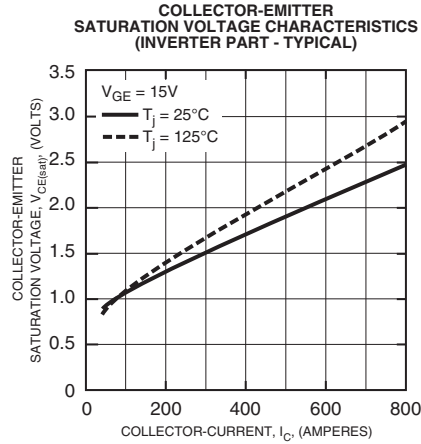
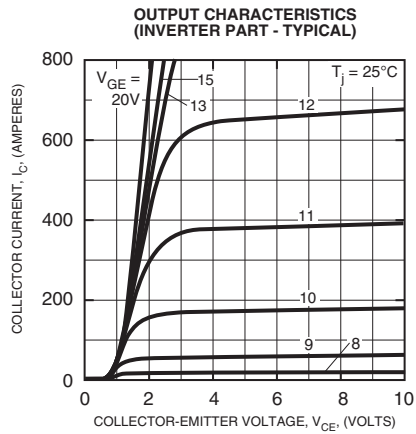

QID0640020

Dual IGBTMOD™ NX-Series Module

400 Amperes/600 Volts

