

isc N-Channel MOSFET Transistor

2SK995

DESCRIPTION

- Drain Current $-I_D=5A @ T_C=25^\circ C$
- Drain Source Voltage-
: $V_{DSS}=550V(\text{Min})$
- Fast Switching Speed

APPLICATIONS

- Designed for high voltage, high speed power switching

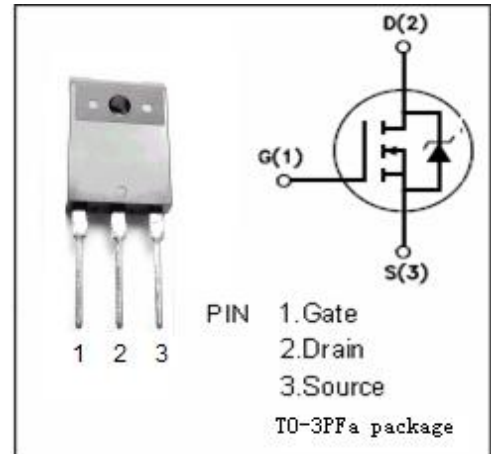

ABSOLUTE MAXIMUM RATINGS($T_a=25^\circ C$)

SYMBOL	PARAMETER	VALUE	UNIT
V_{DSS}	Drain-Source Voltage ($V_{GS}=0$)	550	V
V_{GS}	Gate-Source Voltage	± 20	V
I_D	Drain Current-continuous@ $T_C=25^\circ C$	5	A
P_{tot}	Total Dissipation@ $T_C=25^\circ C$	60	W
T_j	Max. Operating Junction Temperature	150	$^\circ C$
T_{stg}	Storage Temperature Range	-55~150	$^\circ C$

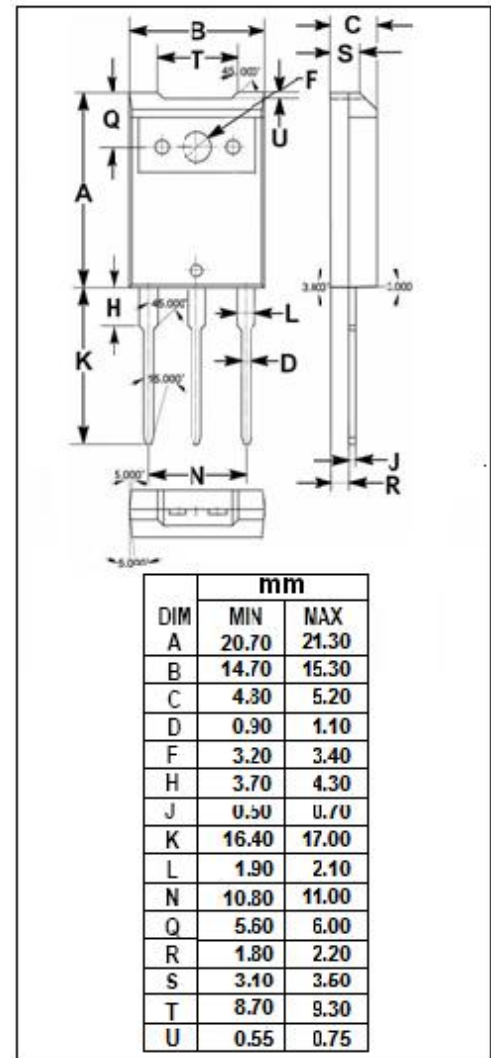

THERMAL CHARACTERISTICS

SYMBOL	PARAMETER	MAX	UNIT
$R_{th\ j-c}$	Thermal Resistance,Junction to Case	1.0	$^\circ C/W$
$R_{th\ j-a}$	Thermal Resistance,Junction to Ambient	62.5	$^\circ C/W$

isc N-Channel Mosfet Transistor

2SK995

• ELECTRICAL CHARACTERISTICS (T_C=25°C)

SYMBOL	PARAMETER	CONDITIONS	MIN	TYP	MAX	UNIT
V _{(BR)DSS}	Drain-Source Breakdown Voltage	V _{GS} =0; I _D = 10mA	550			V
V _{GS(th)}	Gate Threshold Voltage	V _{DS} =25 V _{GS} ; I _D =1mA	1.0		5.0	V
R _{DS(on)}	Drain-Source On-stage Resistance	V _{GS} =10V; I _D = 3A		1.2	1.8	Ω
I _{GSS}	Gate Source Leakage Current	V _{GS} = ±20V; V _{DS} = 0			±1	uA
I _{DSS}	Zero Gate Voltage Drain Current	V _{DS} =440V; V _{GS} = 0			0.1	mA
ton	Turn-on time	V _{GS} =10V; I _D =3A;		50		ns
toff	Turn-off time	R _L =50 Ω		365		ns