

**Three Terminal, Adjustable  
 Negative Voltage Regulator**

**OM1325NK  
 1.5A**

**Product Summary:**

Part Number	Standard Military Drawing Number	$V_{IN}$	Adjustable $V_{OUT}$	Package
OM1325NK	7703406Y	-4.25V to -41.25V	-1.2V to -37V	TO-204



These three terminal negative voltage regulators are supplied in hermetically sealed packages. All protective features are designed into the circuit, including thermal shutdown, current-limiting, and safe-area control. With heat sinking, these devices can deliver up to 1.5 amps of output current. The unit also features output voltages that can be fixed from -1.2 volts to -37 volts using external resistors.

**Features:**

- Similar to Industry Standard LM137A
- Approved to DSCC Standardized Military Drawing Number 7703406
- Built-in Thermal Overload Protection
- Short Circuit Current Limiting
- Maximum Output Voltage Tolerance is Guaranteed  $\pm 1\%$
- This part is also available in  
 TO-257AA Package as OM1325ST (Isolated),  
 TO-257AA Package as OM1325NT (Non-Isolated),  
 SMD-1 Package as OM1325NM,  
 SMD-3 Package as OM1325SM

**Absolute Maximum Ratings @ TC = 25°C**

Parameter	Symbol	Value	Units
Recommended Output Voltage Range	$V_{OUT}$	-1.2 to -37	$V_{DC}$
Recommended Input Voltage Range	$V_{IN}$	-4.25 to -41.25	
Output Current	$I_{OUT}$	1.5	A
Power Dissipation	$P_D$	20	W
Input - Output Voltage Differential	$V_{DIFF}$	40	V
Thermal Resistance, Junction to Case	$R_{THJC}$	3	°C/W
Operating Temperature Range	$T_J$	-55 to +150	°C
Storage Temperature Range	$T_S$	-65 to +150	
Lead Temperature (Soldering 10 seconds)	$T_L$	300	

**Electrical Characteristics:  $-55^{\circ}\text{C} \leq T_A \leq 125^{\circ}\text{C}$ ,  $I_L = 8.0\text{mA}$  (Unless Otherwise Specified)**

Parameter	Test Conditions	Symbol	Min.	Max.	Units
Reference Voltage	$V_{\text{DIFF}} = 3.0\text{V}$ , $T_A = 25^{\circ}\text{C}$	$V_{\text{REF}}$	-1.262	-1.238	V
	$V_{\text{DIFF}} = 3.0\text{V}$ ③		-1.280	-1.220	
	$V_{\text{DIFF}} = 40\text{V}$ ③		-1.280	-1.220	
Line Regulation ①	$3.0\text{V} \leq V_{\text{DIFF}} \leq 40\text{V}$ , $T_A = 25^{\circ}\text{C}$	$R_{\text{LINE}}$	-4.5	4.5	mV
	$3.0\text{V} \leq V_{\text{DIFF}} \leq 40\text{V}$ ③		-13.8	13.8	
Load Regulation ①	$8.0\text{mA} \leq I_L \leq 1.5\text{A}$ , $V_{\text{DIFF}} = 5.0\text{V}$ ③	$R_{\text{LOAD}}$	-25	25	
	$8.0\text{mA} \leq I_L \leq 1.5\text{A}$ , $V_{\text{DIFF}} = 12\text{V}$ , $T_A = 25^{\circ}\text{C}$		-25	25	
	$8.0\text{mA} \leq I_L \leq 200\text{mA}$ , $V_{\text{DIFF}} = 40\text{V}$ , $T_A = 25^{\circ}\text{C}$		-25	25	
	$8.0\text{mA} \leq I_L \leq 100\text{mA}$ , $V_{\text{DIFF}} = 40\text{V}$ ③		-50	50	
Thermal Regulation	$V_{\text{IN}} = -14.6\text{V}$ , $I_L = 1.5\text{A}$ $P_D = 20\text{W}$ , $t = 10\text{ms}$ , $T_A = 25^{\circ}\text{C}$	$V_{\text{RTH}}$	-5.0	5.0	
Ripple Rejection ②	$f = 120\text{Hz}$ , $V_{\text{OUT}} = V_{\text{REF}}$ ③ $C_{\text{ADJ}} = 10\mu\text{F}$	$R_{\text{IN}}$	66	-	dB
Adjustment Pin Current	$V_{\text{DIFF}} = 3.0\text{V}$ ③	$I_{\text{ADJ}}$	-	100	$\mu\text{A}$
	$V_{\text{DIFF}} = 40\text{V}$ ③		-	100	
Adjustment Pin Current Change	$3.0\text{V} \leq V_{\text{DIFF}} \leq 40\text{V}$ ③	$I_{\text{ADJ (line)}}$	-5.0	5.0	$\mu\text{A}$
	$8.0\text{mA} \leq I_L \leq 1.5\text{A}$ , $V_{\text{DIFF}} = 5.0\text{V}$ ③	$I_{\text{ADJ (load)}}$	-5.0	5.0	
Minimum Load Current	$V_{\text{DIFF}} = 3.0\text{V}$ , $V_{\text{OUT}} = -1.4\text{V (forced)}$ ③	$I_{\text{Lmin}}$	-	3.0	mA
	$V_{\text{DIFF}} = 10\text{V}$ , $V_{\text{OUT}} = -1.4\text{V (forced)}$ ③		-	3.0	
	$V_{\text{DIFF}} = 40\text{V}$ , $V_{\text{OUT}} = -1.4\text{V (forced)}$ ③		-	5.0	
Current Limit ②	$V_{\text{DIFF}} = 5.0\text{V}$ ③	$I_{\text{CL}}$	1.5	3.5	A
	$V_{\text{DIFF}} = 40\text{V}$ , $T_A = 25^{\circ}\text{C}$		0.24	1.2	

## NOTES:

- ① Load and Line Regulation are specified at a constant junction temperature. Pulse testing with low duty cycle is used. Changes in output voltage due to heating effects must be taken into account separately.
- ② If not tested, shall be guaranteed to the specified limits.
- ③ Denotes the specifications which apply over the full operating temperature range.

Standard Application

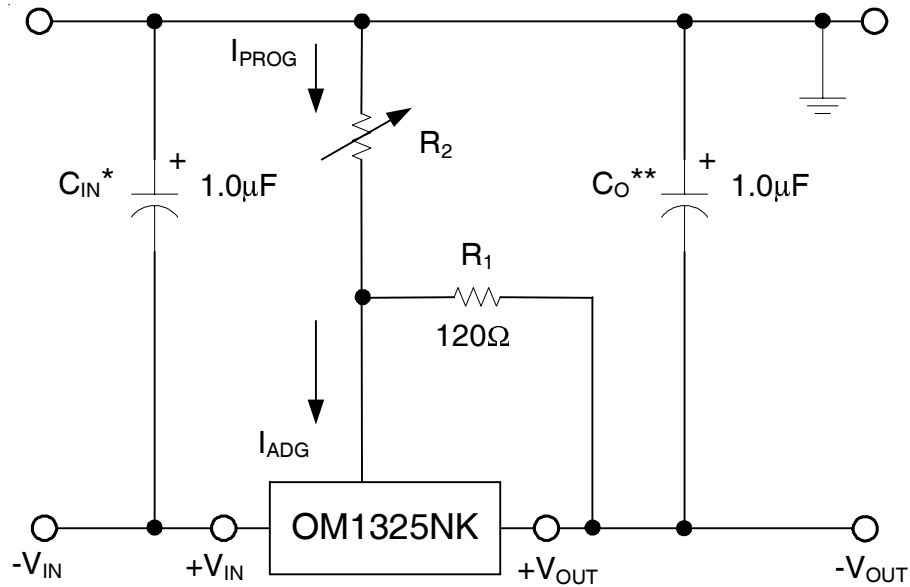

\*  $C_{in}$  is required if regulator is located more than 4 inches from power supply filter. A  $1.0\mu\text{F}$  solid tantalum or  $10\mu\text{F}$  aluminum electrolytic is recommended.

\*\*  $C_o$  is necessary for stability. A  $1.0\mu\text{F}$  solid tantalum or  $10\mu\text{F}$  aluminum electrolytic is recommended.

$$V_{OUT} = -1.25V (1 + R2/R1)$$

**Case Outline and Dimensions -TO-204**

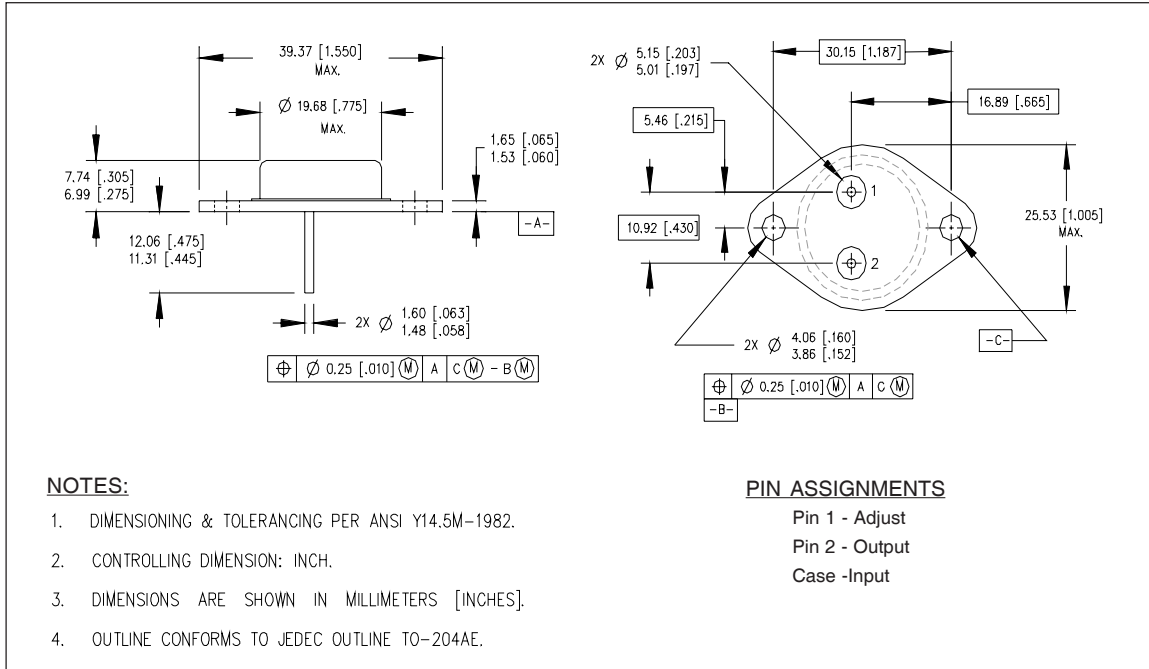

**Part Numbering Nomenclature**

