

DESCRIPTION

The GC9000 series of spiral bias element chips are photolithographically fabricated planar spiral conductors supported on a high quality fused quartz substrate. These devices are designed to meet hybrid microwave circuit requirements for DC power injection through Ku (or J) band. The actual spiral bias element, consists of a 5 micron, nominal, thick plated gold spiral trace with a 3 mil diameter bonding pad at either end.

A dense passivation is applied on the conductive portion of the spiral geometry so that undesirable environmental or particulate effects during operation can be prevented. The bonding pads are left exposed to provide easy, low resistance lead attachment.

Fused quartz substrates are used to minimize dielectric losses, near zero T_{CE} and provide durability during handling and assembly.

Contemporary fabrication processes combined with Microsemi Lowell's extensive experience in microwave component and hybrid circuit engineering has generated a product that will be both operationally predictable and reliable when used as a means to supply DC to a small signal hybrid microwave circuit.

This series of devices meets RoHS requirements per EU Directive 2002/95/EC. The standard terminal finish is gold unless otherwise specified. Consult the factory if you have special requirements.

APPLICATIONS

Bias injection into oscillators, amplifiers and microwave switches (bias tees). Can be used to bias tuning varactor diodes, pin diodes, transistors and monolithic circuit components. These spiral elements provide extreme freedom from in band resonance; very smooth wide frequency response.

**ABSOLUTE MAXIMUM RATINGS AT 25° C
(UNLESS OTHERWISE SPECIFIED)**

Rating	Symbol	Value	Unit
Working Current	I	250	mA
Storage Temperature	T_{STG}	-65 to +200	°C
Operating Temperature	T_{OP}	-55 to +150	°C

KEY FEATURES

- Dimensional Uniformity
- Planar Design
- Passivated Spiral Element
- Physical and Dimensional Stability Through Temp Cycle and Vibration
- Models as a Lossy Transmission Line
- Eliminates Potting or Coating Wire-wound Coils
- Designed for Microwave Applications From 2 to 18 GHz
- Reduced Assembly Costs
- RoHS Compliant¹

APPLICATIONS/BENEFITS

- RF Bias Networks
- Wideband performance



IMPORTANT: For the most current data, consult our website: www.MICROSEMI.com
Specifications are subject to change, consult factory for the latest information.



These devices are ESD sensitive and must be handled using ESD precautions.

¹ These devices are supplied with gold terminations suitable for wire-bonding.

ELECTRICAL PARAMETERS @ 25°C (unless otherwise specified)			
Model Number	L(nH) (Typ)	R _{DC} (Ohms) (Typ)	OUTLINE
GC9005	3	1.0	A
GC9001	6	1.5	A
GC9006	10	2.0	B
GC9002	15	2.5	B
GC9007	21	3.5	C
GC9008	28	4.0	C
GC9003	36	5.0	C
GC9009	45	6.0	D
GC9010	55	7.0	D
GC9011	68	8.0	D
GC9004	78	8.5	D

MECHANICAL DIMENSIONS		
OUTLINE	Chip L(A) X W(B) (Inches) (Max)	Chip Thickness(C) (Inches) (+/-0.002)
A	0.031" X 0.031"	0.011
B	0.032" X 0.032"	0.011
C	0.041" X 0.041"	0.011
D	0.061" X 0.061"	0.011

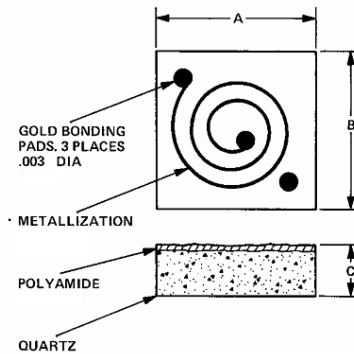
SPIRAL INDUCTOR OUTLINE DRAWING
(2 1/2 TURN SPIRAL SHOWN)

RECOMMENDED CHIP ATTACHMENT AND LEAD BONDING PROCEDURES

CHIP ATTACHMENT

Chip attachment to hybrid circuits or module bodies can be accomplished with either conductive or nonconductive epoxy paste. EPO TEK H-61 or EPO TEK H-20 are examples of some commonly used epoxy pastes

RIBBON OR WIRE BONDING

Thermo-compression bonding is recommended. A temperature of 175°C with pressure of 25 grams would be adequate for bonding most gold ribbon or wire. For optimum performance, attach RF input to pad at center of coil and the bypass network (capacitance) to outside pad.