

**LIQUID CRYSTAL DISPLAY MODULE**

**G121C00P000**

**G121CB1P000**

**USER'S MANUAL**

**Seiko Instruments Inc.**

## NOTICE

This manual describes the technical information, as well as the functions and operation of the G121C Liquid Crystal Display Module made by Seiko Instruments Inc. Please read this manual carefully to familiarize yourself with the functions so you can make the best use of them.

The descriptions here are subject to change without notice.

### Revision Record

<u>Edition</u>	<u>Revision</u>	<u>Date</u>
1	Original	Sept. 1994
2		Oct. 1994
3		June 1995

© Seiko Instruments Inc. 1994

Printed in Japan

## CONTENTS

### G121C00P000, G121CB1P000

#### 1. SPECIFICATIONS

1.1 General .....	1
1.2 Features .....	1
1.3 Absolute Maximum Ratings (excluding LED backlight) .....	2
1.4 Mechanical Characteristics .....	2
1.5 Electrical Characteristics (excluding LED backlight) .....	2
1.6 Optical Characteristics .....	3
1.7 LCD Panel Lifetime .....	4
1.8 Dimensions .....	5

#### 2. CIRCUIT CONFIGURATION

2.1 Liquid Crystal Driving Circuit .....	6
2.2 Circuit Configuration .....	8
2.3 Timing Characteristics .....	12
2.4 Interface Circuit .....	14

### G121CB1P000

#### 3. LED BACKLIGHT

3.1 Absolute Maximum Ratings .....	18
3.2 Electrical and Optical Characteristics .....	18
3.3 LED Backlight Connection Diagram .....	18
3.4 Brightness (panel upper side) .....	18
3.5 Lifetime .....	19
3.6 Examples of LED Backlight Drivers .....	19

### G121C00P000, G121CB1P000

4. PRECAUTIONS .....	21
----------------------	----

#### INDEX

## 1. SPECIFICATIONS

### 1.1 General

The G121C is a very thin LCD module on which a full-dot matrix LCD panel and a CMOS IC driver are integrated. The LCD panel used here features wide viewing angle and high contrast. This full dot configuration allows a wide variety of patterns to be displayed depending upon the input data. The display position is the intersection point of the matrix transparent electrodes. This prevents display distortion and displacement.

### 1.2 Features

#### G121C00P000/G121CB1P000

- 128 x 128 full dot matrix configuration
- 1/128 duty, 1/10 bias
- Four-bit parallel data input
- A wide temperature range, gray mode STN LCD panel
- Positive display
  - Display data "H": Display ON: blue display color
  - Display data "L": Display OFF: gray background

#### G121C00P000

- Dual power supplies :  $V_{DD} = +5\text{ V}$ ,  $V_{LC} = -24\text{ V}$  (for driving liquid crystal)
- Reflective type
- Weight : Approx. 59 g

#### G121CB1P000

- Triple power supplies :  $V_{DD} = +5\text{ V}$ ,  $V_{LC} = -24\text{ V}$ , LEDA (for driving LED)
- Transflective type
- A built-in LED backlight (color: yellow-green)
- Weight : Approx. 75 g

### 1.3 Absolute Maximum Ratings (excluding LED backlight)

$V_{SS} = 0\text{ V}$

Item	Symbol	Conditions	Min.	Max.	Unit
Power supply voltage	$V_{DD}$		0	7.0	V
	$V_{LC}$		$V_{DD} - 30.0$	$V_{DD}$	V
	$V_O$	$V_O \geq V_{LC}$	$V_{DD} - 30.0$	$V_{DD}$	V
Input voltage	$V_{IN}$		-0.3	$V_{DD} + 0.3$	V
Operating temperature	$T_{opr}$	$\leq 65\%RH$	-20	+70	°C
Storage temperature	$T_{stg}$		-30	+80	°C
Storage humidity		$\leq 48\text{ hrs}$	+20	+85	%RH
		$\leq 1000\text{ hrs}$	+20	+65	%RH

### 1.4 Mechanical Characteristics

Item	Standard
Dot configuration	128 × 128 dots
Module dimensions (H × V × T) [mm]	G121C00P000 : 86.0 × 95.0 × 7.0 G121CB1P000 : 86.0 × 95.0 × 9.0
Viewing area (H × V) [mm]	67.4 × 67.4
Active display area (H × V) [mm]	62.69 × 62.69
Dot dimensions (H × V) [mm]	0.46 × 0.46
Dot pitch (H × V) [mm]	0.49 × 0.49
Weight [g]	G121C00P000 : 75 max. G121CB1P000 : 100 max.

H : Horizontal    V : Vertical    T : Thickness (max.)

### 1.5 Electrical Characteristics (excluding LED backlight)

$V_{DD} = 5\text{ V} \pm 5\%$ ,  $V_{SS} = 0\text{ V}$ ,  $T_a = -20^\circ\text{C}$  to  $+70^\circ\text{C}$

Item	Symbol	Conditions	Min.	Typ.	Max.	Unit
Power supply voltage	$V_{DD}$		4.75	5.00	5.25	V
	$V_{LC}$	$V_{DD} = 5\text{ V}$ $V_O \geq V_{LC}$	-24.5	-24.0	-23.5	V
	$V_O$		-23.0	-	-5.0	V
Input voltage	High	$V_{IH}$	$0.8 V_{DD}$	-	$V_{DD}$	V
	Low	$V_{IL}$	0	-	$0.2 V_{DD}$	V
Current consumption*1	$I_{DD}$	$V_{DD} = 5\text{ V}$ , $T_a = 25^\circ\text{C}$ $V_O = -15.0\text{ V}$ $f_{FLM} = 70\text{ Hz}$	-	4.3	8.6	mA
	$I_{LC}$		-	4.1	8.2	mA
Frame frequency	$f_{FLM}$		65	70	75	Hz

\*1 Display patterns: checkered patterns.  
Display data shift clock frequency:  $f_{CL2} = 3.0\text{ MHz}$

## 1.6 Optical Characteristics

### 1.6.1 G121C00P000

1/128 duty, 1/10 bias,  $f_{FLM} = 70 \text{ Hz}$ ,  $V_{opr} = V_{DD} - V_O$

Item	Symbol	Conditions	Temp.	Min.	Typ.	Max.	Unit	Reference
Viewing angle	$\theta_1$	$C \geq 2.0$ $\varnothing = 0^\circ$ $V_{opr} = 20.0 \text{ V}$	25°C	-	-	- 5	Degree	Notes 1 & 2
	$\theta_2$			50	-	-		
	$\theta_2 - \theta_1$			55	-	-		
Contrast	C	$\theta = 0^\circ$ $\varnothing = 0^\circ$ $V_{opr} = 20.0 \text{ V}$	25°C	2.5	3.5	-	-	Note 3
Response time	$t_{on}$	$\theta = 0^\circ$ $\varnothing = 0^\circ$ $V_{opr} = 20.0 \text{ V}$	25°C	-	150	240	ms	Note 4
	$t_{off}$			-	110	180		
	$t_{on}$	$\theta = 0^\circ$ $\varnothing = 0^\circ$ $V_{opr} = 21.5 \text{ V}$	- 10°C	-	1060	1700		
	$t_{off}$			-	500	800		
	$t_{on}$	$\theta = 0^\circ$ $\varnothing = 0^\circ$ $V_{opr} = 22.0 \text{ V}$	- 20°C	-	2860	4600		
	$t_{off}$			-	780	1300		

Measuring instrument : Canon illuminometer LC-35

### 1.6.2 G121CB1P000

1/128 duty, 1/10 bias,  $f_{FLM} = 70 \text{ Hz}$ ,  $V_{opr} = V_{DD} - V_O$ , LED backlight: ON

Item	Symbol	Conditions	Temp.	Min.	Typ.	Max.	Unit	Reference
Viewing angle	$\theta_1$	$C \geq 1.4$ $\varnothing = 0^\circ$ $V_{opr} = 20.0 \text{ V}$	25°C	-	-	- 20	Degree	Notes 1 & 2
	$\theta_2$			30	-	-		
	$\theta_2 - \theta_1$			50	-	-		
Contrast	C	$\theta = 0^\circ$ $\varnothing = 0^\circ$ $V_{opr} = 20.0 \text{ V}$	25°C	2.0	2.4	-	-	Note 3
Response time	$t_{on}$	$\theta = 0^\circ$ $\varnothing = 0^\circ$ $V_{opr} = 20.0 \text{ V}$	25°C	-	150	240	ms	Note 4
	$t_{off}$			-	110	180		
	$t_{on}$	$\theta = 0^\circ$ $\varnothing = 0^\circ$ $V_{opr} = 21.5 \text{ V}$	- 10°C	-	1060	1700		
	$t_{off}$			-	500	800		
	$t_{on}$	$\theta = 0^\circ$ $\varnothing = 0^\circ$ $V_{opr} = 22.0 \text{ V}$	- 20°C	-	2860	4600		
	$t_{off}$			-	780	1300		

Measuring instrument : Canon illuminometer LC-35

Note 1: Definition of angle  $\theta$  and  $\varnothing$

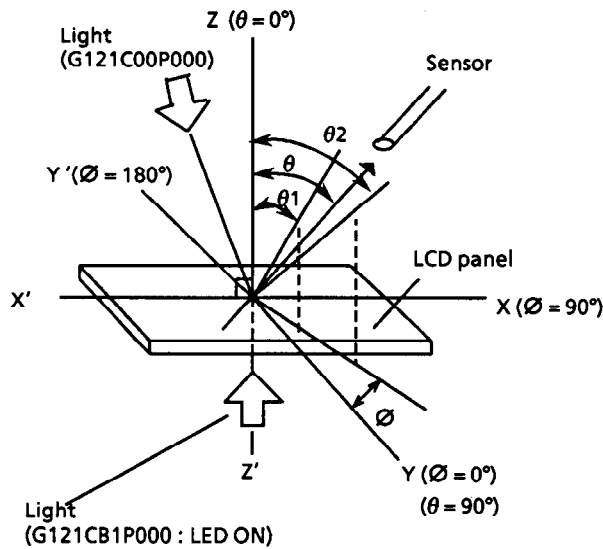

Note 2: Definition of viewing angles  $\theta_1$  and  $\theta_2$

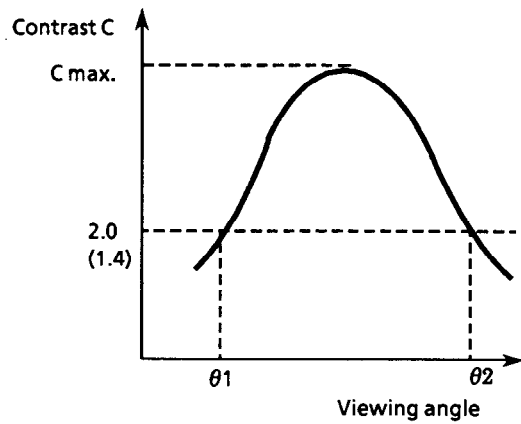

Remark : The optimum viewing angle by visual inspection and angle  $\theta$  at  $C_{max}$  do not always match.

Note 3: Definition of contrast (C)

$$C = \frac{\text{Brightness of non-selected dot } B_2}{\text{Brightness of selected dot } B_1}$$

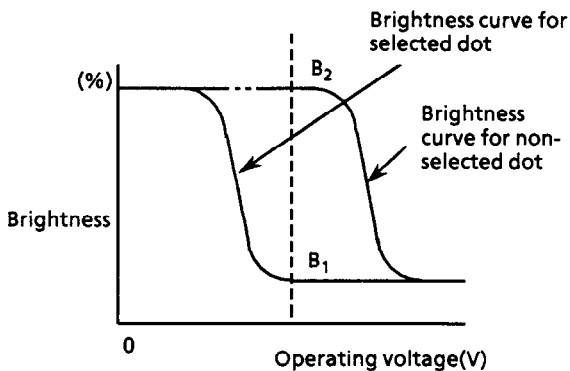

Note 4: Definition of response time

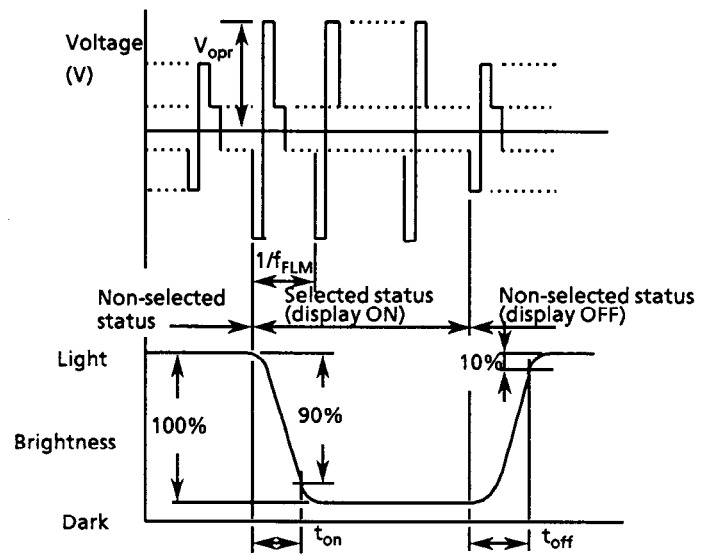

$V_{opr}$  : Operating voltage       $t_{on}$  : Response time (rise)  
 $f_{FLM}$  : Frame frequency       $t_{off}$  : Response time (fall)

Note: Measurement must be made using a G121C transmissive LCD panel.

Figure 1 Definition

### 1.7 LCD Panel Lifetime

Item	Conditions	Standard	Unit
Lifetime*	25°C ± 10°C < 65% RH	100,000 or more	hrs

\* Definition of lifetime: the time up to occurrence of any of the following:

- Contrast reduces to 30% of the initial value.
- Current consumption becomes three times the initial value.
- Orientation deteriorates significantly.
- The display malfunctions.

1.8 Dimensions

Unit : mm  
General tolerance : ± 0.5

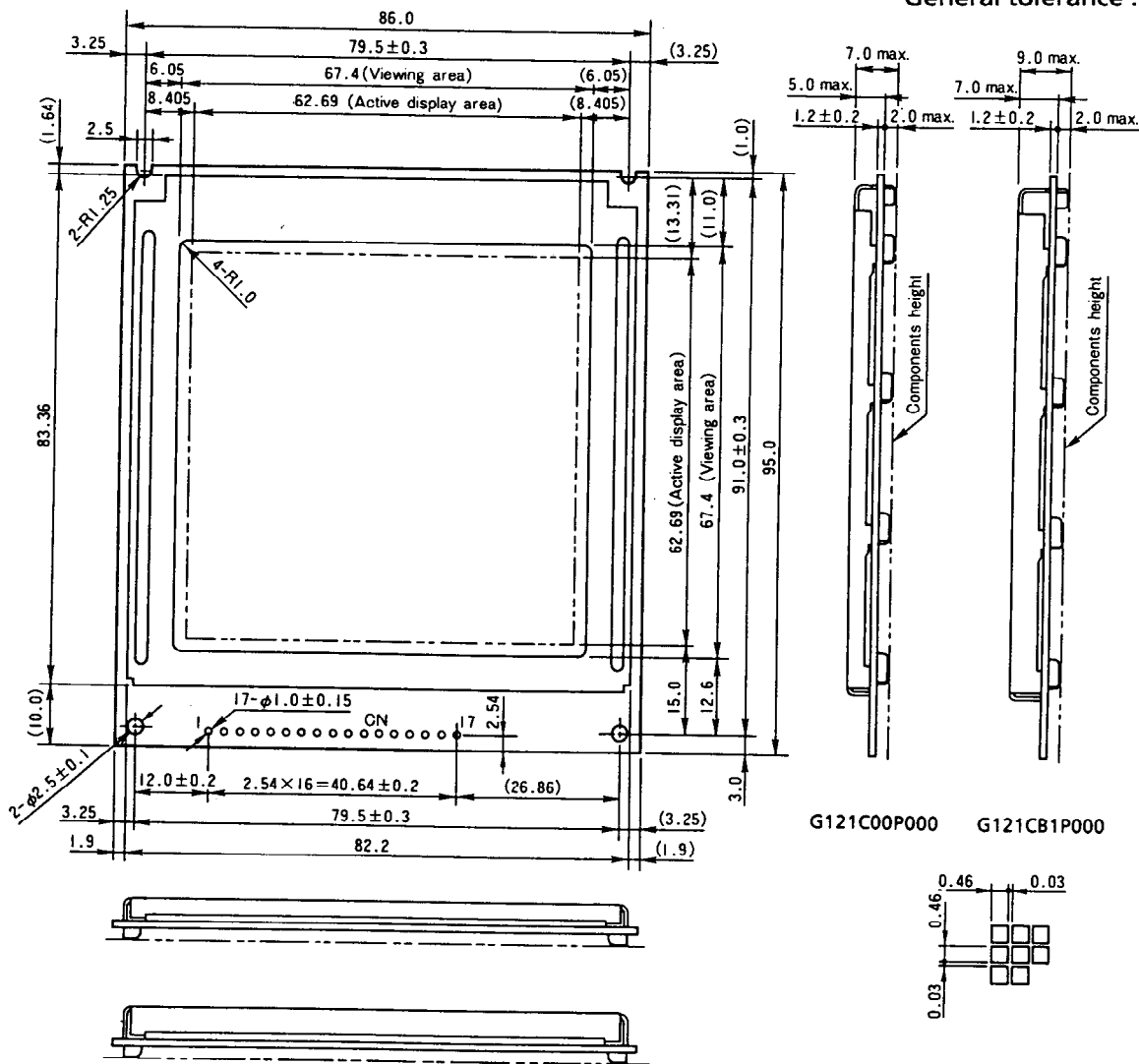

Figure 2 Dimensions

[I/O terminal functions]

No.	Symbol	Functions
1	V <sub>DD</sub>	Power supply for logic : + 5 V
2	F <sub>GND</sub>	Frame ground*1
3	CL2	Display data shift clock
4	INH	Display ON/OFF control terminal*2
5	FLM	One-frame timing signal
6	CL1	One-common-line timing signal
7	V <sub>SS</sub>	GND : 0 V
8	M	NC
9	D0	Display data input

No.	Symbol	Functions
10	D1	Display data input
11	D2	Display data input
12	D3	Display data input
13	V <sub>LC</sub>	Power supply for LC drive : - 24 V
14	V <sub>O</sub>	Liquid crystal drive voltage adjustment terminal
15	V <sub>SS</sub>	GND : 0 V
16	NC/LEDA	— *3
17	NC/LEDC	— *3

\*1 The F<sub>GND</sub> terminal is connected to the module metal frame. Use this terminal to ground the frame.

\*2 The display is ON when INH is H, and OFF when L.

\*3 G121C00P000 : NC

G121CB1P000 : Power supply for LED drive(No.16 : LEDA, No.17 : LEDC)



## 2. CIRCUIT CONFIGURATION

### 2.1 Liquid Crystal Driving Circuit

The G121C LCD panel drive waveform is shown in Figure 3. Since DC voltage will damage the liquid crystal, AC voltage is applied between the two frames. The signal controlling this is the liquid crystal AC drive control signal *M*.

Depending on the LCD panels, increasing the liquid crystal AC drive waveform frequency may improve the display quality. The G121C contains a circuit that generates AC drive control signal *M'*, which has a higher frequency than that of *M*. The frequency of the *M'* signal is adjusted according to the LCD panel to provide the best display quality.

The frame frequency is normally set to  $70 \pm 5$  Hz to prevent screen flicker.

The G121C has a 1/128 duty cycle, and the common electrodes are selected within a frame by time division from electrode 1 to electrode 128. This is called line sequential scanning. The voltage level of the segment electrodes determines whether or not the dots at the intersection of the segment electrodes are selected when the common electrode is selected. As shown in Table 1, there are six drive waveform voltage levels,  $V_a$  to  $V_f$ . The voltage level is determined by the bias value. The voltage between the segment and common electrodes is then applied to the liquid crystal. The selection waveform for  $SEG_0-COM_0$  and the non-selection waveform for  $SEG_1-COM_1$  are shown in Figure 3. The size of the effective voltage of the waveform determines whether the liquid crystal under the selected dots is in the selection or non-selection state.

Table 1

$V_a$	Common and segment selection level
$V_b$	Common non-selection level
$V_c$	Segment non-selection level
$V_d$	Segment non-selection level
$V_e$	Common non-selection level
$V_f$	Common and segment selection level

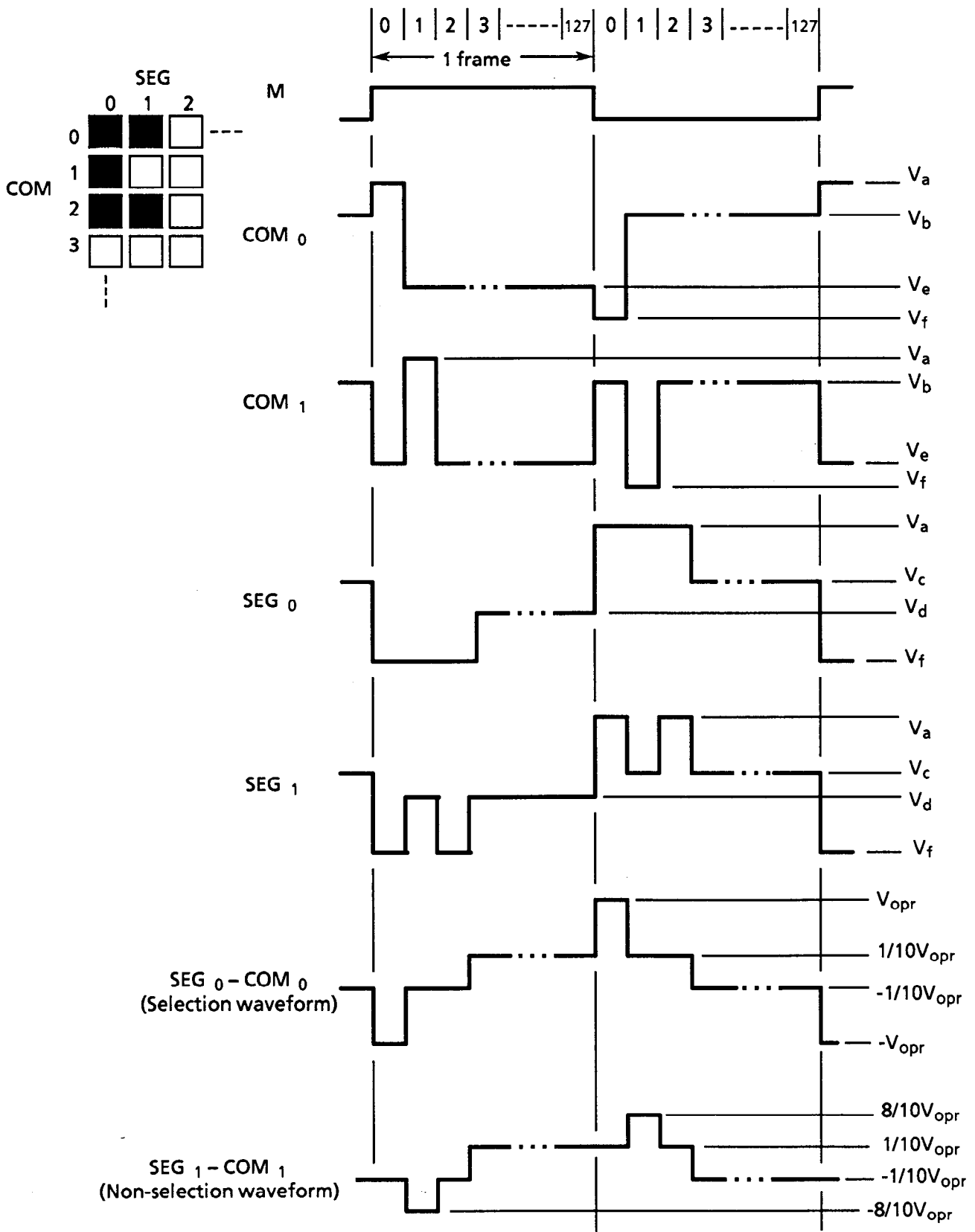
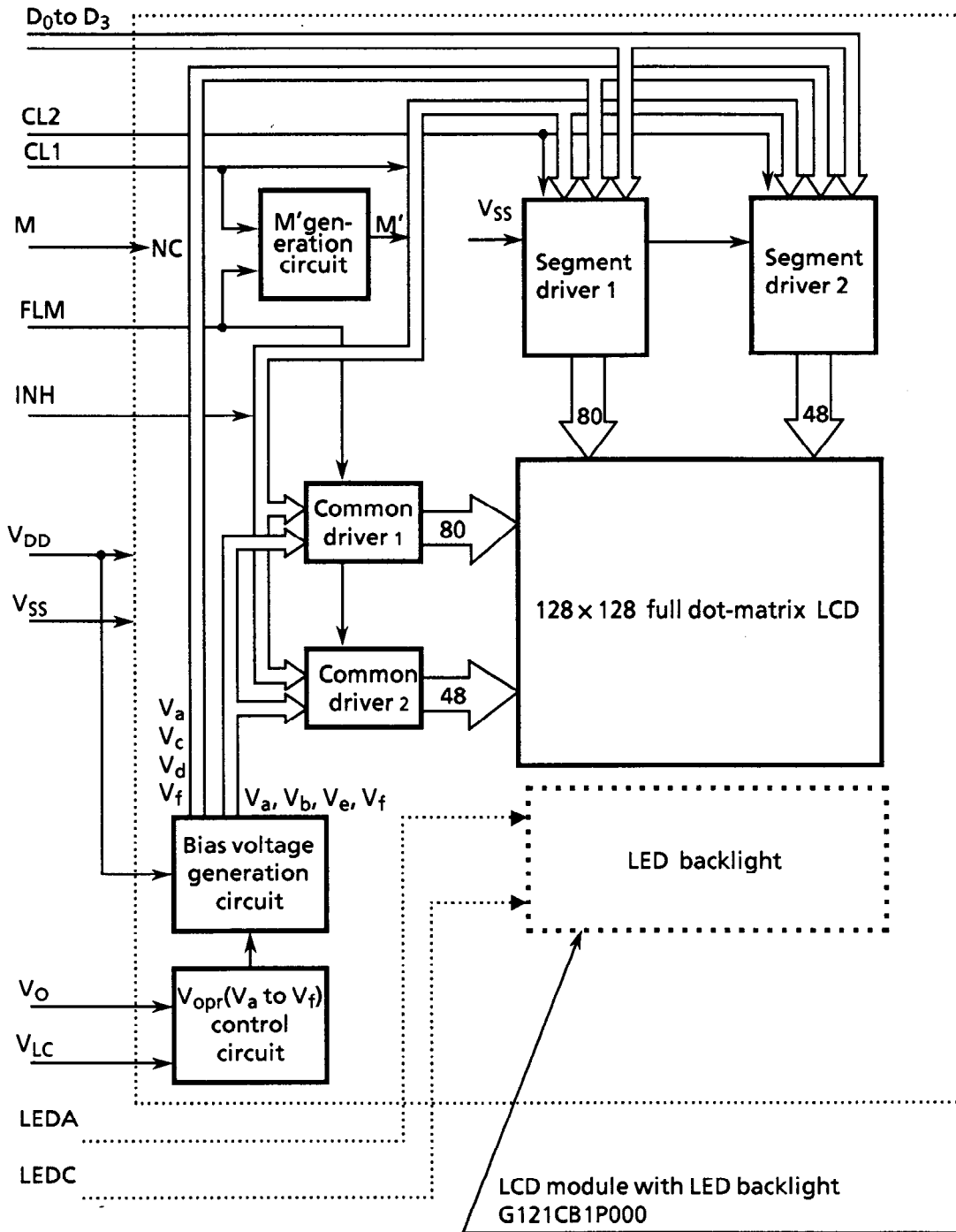

Figure 3 Drive Waveform

### 2.2 Circuit Configuration

The G121C consists of common drivers, segment drivers, a bias voltage generation circuit, an M' generation circuit and a V<sub>opr</sub> control circuit. Figure 4 shows the block diagram for the G121C.



Common drivers : HD66205TF  
 Segment drivers : HD66204TF

Figure 4 Block Diagram for G121C

## (1) Common driver (HITACHI HD66205TF)

A common driver (CD) is a CMOS IC with 80 drive outputs. The G121C has two CDs, whose internal registers are connected to each other. They operate as follows.

Input one-frame timing signal (FLM) is taken into the internal shift register by the falling edge trigger of the one-common-line timing signal (CL1), and sequentially shifted. After 128-CL1 input, the next FLM is input and the same operation is repeated. As shown in Table 2, the common output is selected according to the shift register contents and the internally-generated liquid crystal AC drive control signal ( $M'$ ) in the drive circuit, and the common drive waveform are formed.

Table 2 Common Output

INH	Shift register content	$M'$	COM output	Display
H	H	H	$V_a$	ON
		L	$V_f$	
	L	H	$V_e$	
		L	$V_b$	
L	X	X	$V_a$	OFF

x: Invalid

The common output is controlled by the INH signal; when the INH signal is low, the common output is  $V_a$ , irrespective of the shift register contents or the  $M'$  signal.

## (2) Segment driver (HITACHI HD66204TF)

A segment driver (SD) is a CMOS IC with 80 drive outputs. The G121C has two SDs, which operate as follows.

Input four-bit data is sequentially taken into the internal register by the falling edge trigger of the display data shift clock (CL2). The SDs have a chip enable function. After 80 bits of data are taken into SD1, the next bit of data is automatically taken into SD2. Since G121C has two SDs, 128 bits of data can be taken. The display data taken into the internal register are latched by the falling edge trigger of CL1. The segment output is selected according to this display data and  $M'$  in the drive circuit, and the segment drive waveform is formed as shown in the Table 3.

Table 3 Segment Output

INH	Display data	$M'$	SEG output	Display
H	H	H	$V_f$	ON
		L	$V_a$	
	L	H	$V_d$	
		L	$V_c$	
L	X	X	$V_a$	OFF

x: Invalid

The segment output is controlled by the INH signal. When the INH signal is low,  $V_a$  is output to the segment, irrespective of the display data and of the  $M'$  signal.

Therefore, by bringing the INH signal to low,  $V_a$  is output both to the common and to the segment electrodes, making the voltage applied to the liquid crystal zero, and the display goes off.

The relationship between the display data and display screen is shown below..

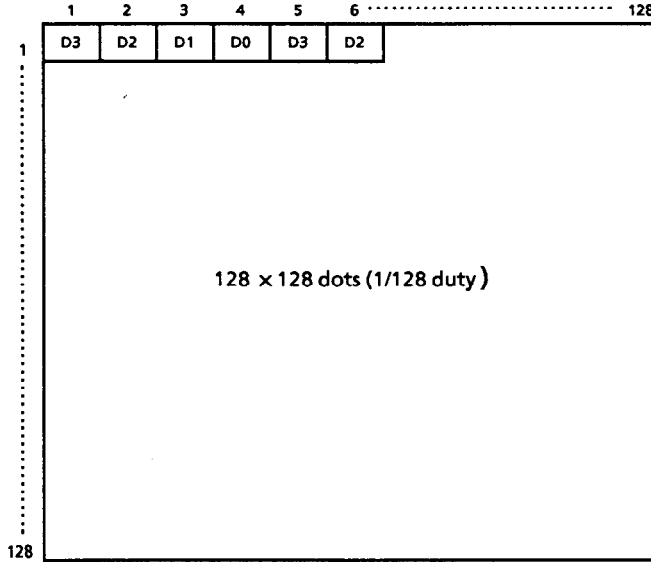

Figure 5 Relationship between the Display Data and Display Screen

(3)  $V_{opr}$  control circuit

Display screen contrast and viewing angle are affected by changes in the liquid crystal operating voltage ( $V_{opr}$ ). As shown in Figure 6, external  $V_{LC}$  is supplied to the operational amplifier and  $V_{opr}$  ( $V_a$  to  $V_f$ ) is generated and applied to the LCD panel.

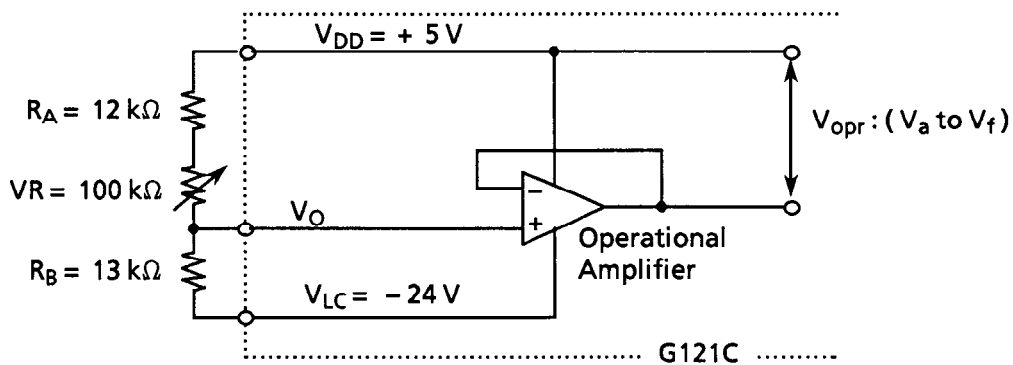

Figure 6  $V_{opr}$  Control Circuit

Also, display screen contrast and viewing angle are influenced by the ambient temperature. The recommended  $V_{opr}$  level at different temperatures is as follows.

Table 4 Liquid Crystal Operating Voltage

Temperature (°C)	-20	0	25	50	70
Liquid crystal operating voltage ( $V_{opr}$ )* (V)	22.0	21.5	20.0	19.0	18.0

\*  $V_{opr} \approx V_{DD} - V_O$

(4) Bias voltage generation circuit

Six voltage levels,  $V_a$  to  $V_f$ , are applied to the common and segment drivers. The voltage is generated through operational amplifiers by resistance division from the liquid crystal operating voltage ( $V_{opr}$ ). Here, an operational amplifier is used as a voltage follower.

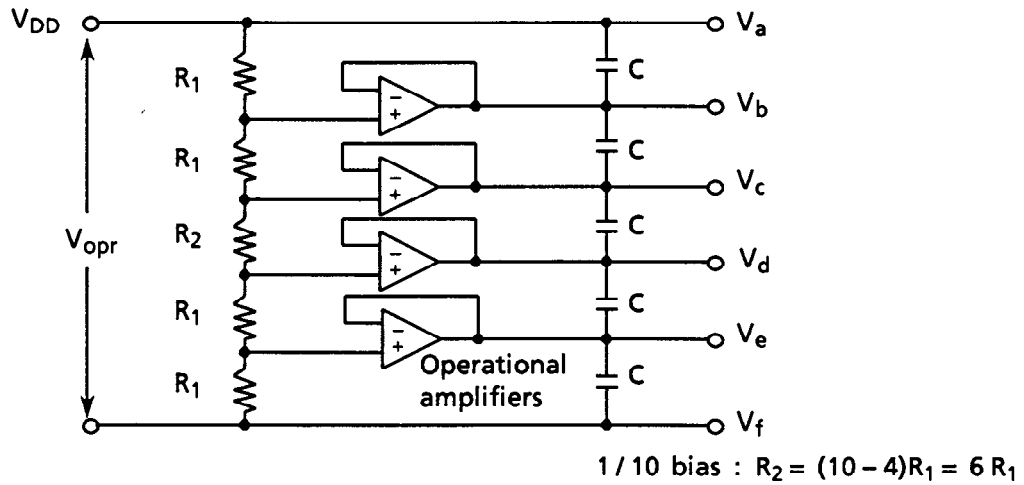

Figure 7 Bias Voltage Generation Circuit

(5)  $M'$  generation circuit

As Figure 8 shows, the  $M'$  generation circuit performs an XOR on the one-common-line timing signal (CL1) (on which A time division is performed) and the one-frame timing signal (FLM) (on which B time division is performed), and outputs liquid crystal AC drive control signal  $M'$ . Values A and B are set according to the LCD panel so that the best display quality can be obtained and the drive voltage can be changed.

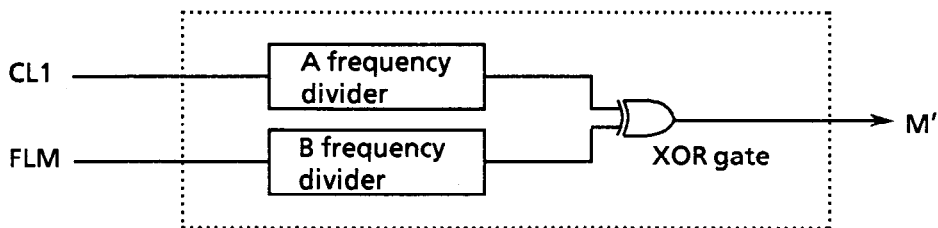

Figure 8  $M'$  Generation Circuit

## 2.3 Timing Characteristics

### 2.3.1 Power ON/OFF and Signal Input Timing

Power ON/OFF and signal input should be performed according to the timing shown in the figure below in order not to damage the LCD driving circuit and the LCD panel.

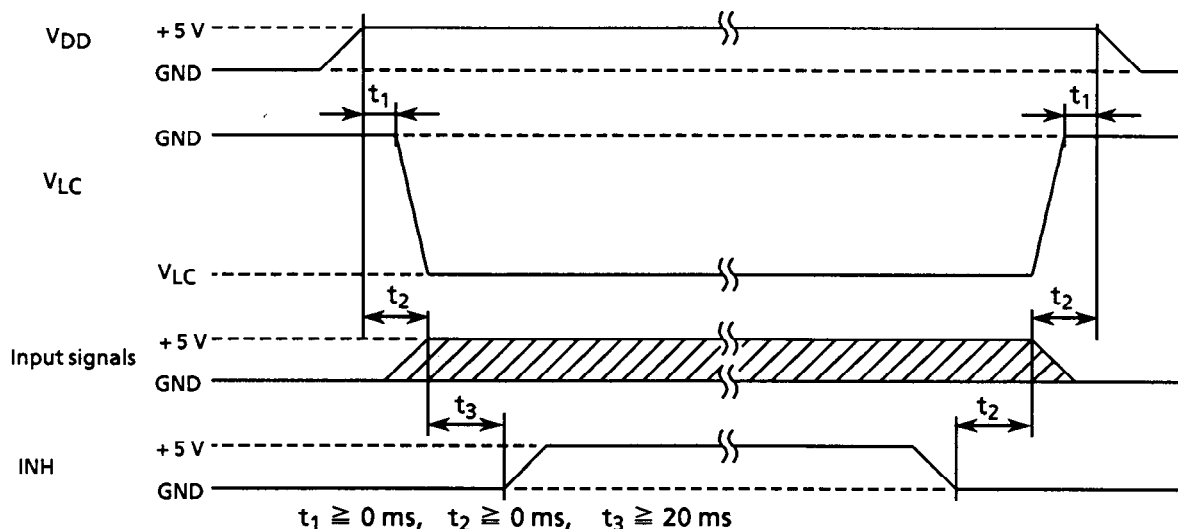

Figure 9 Power ON/OFF and Signal Input Timing

### 2.3.2 Timing Characteristics

$T_a = -20^\circ\text{C to } 70^\circ\text{C}$   $V_{DD} = 5.0\text{V} \pm 5\%$   $V_{SS} = 0\text{V}$

Item	Symbol	Min.	Typ.	Max.	Unit
FLM cycle time	$t_{CFLM}$	13.3	14.3	15.4	ms
CL1 cycle time	$t_{CCL1}$	10	111.6	—	$\mu\text{s}$
CL1 high level width	$t_{WCL1H}$	50	—	—	ns
CL1 low level width	$t_{WCL1L}$	1	—	—	$\mu\text{s}$
CL1 rise time	$t_{RCL1}$	—	—	30	ns
CL1 fall time	$t_{FCL1}$	—	—	30	ns
FLM setup time	$t_{FLMS}$	100	—	—	ns
FLM hold time	$t_{FLMH}$	100	—	—	ns
Allowable M delay time	$t_{DM}$	—	—	300	ns
CL2 cycle time	$t_{CCL2}$	125	—	—	ns
CL2 high level width	$t_{WCL2H}$	45	—	—	ns
CL2 low level width	$t_{WCL2L}$	45	—	—	ns
CL2 rise time	$t_{RCL2}$	—	—	50*	ns
CL2 fall time	$t_{FCL2}$	—	—	50*	ns
Data setup time	$t_{DS}$	20	—	—	ns
Data hold time	$t_{DH}$	20	—	—	ns
CL2 rise to CL1 rise	$t_{LD}$	—	—	—	ns
CL2 fall to CL1 fall	$t_{SL}$	80	—	—	ns
CL1 rise to CL2 rise	$t_{LS}$	—	—	—	ns
CL1 fall to CL2 fall	$t_{LH}$	80	—	—	ns

\*  $t_{RCL2}, t_{FCL2} < \frac{t_{CCL2} - t_{WCL2H} - t_{WCL2L}}{2}$

**Timing Chart 1: Timing of Signal Input Into Common Driver**

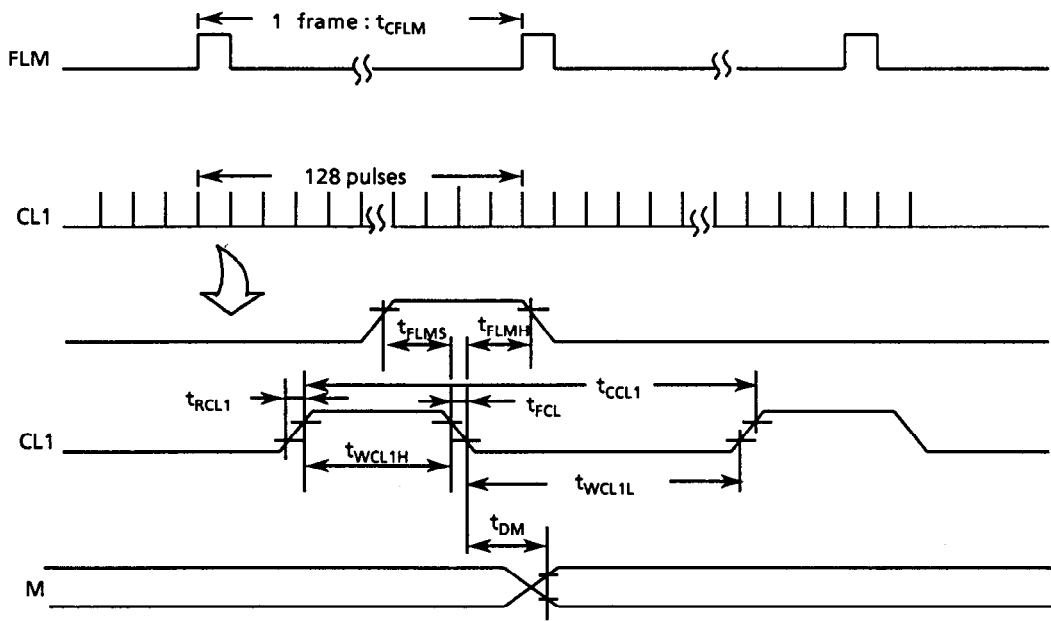

**Figure 10**

**Timing Chart 2: Timing of Signal Input Into Segment Driver**

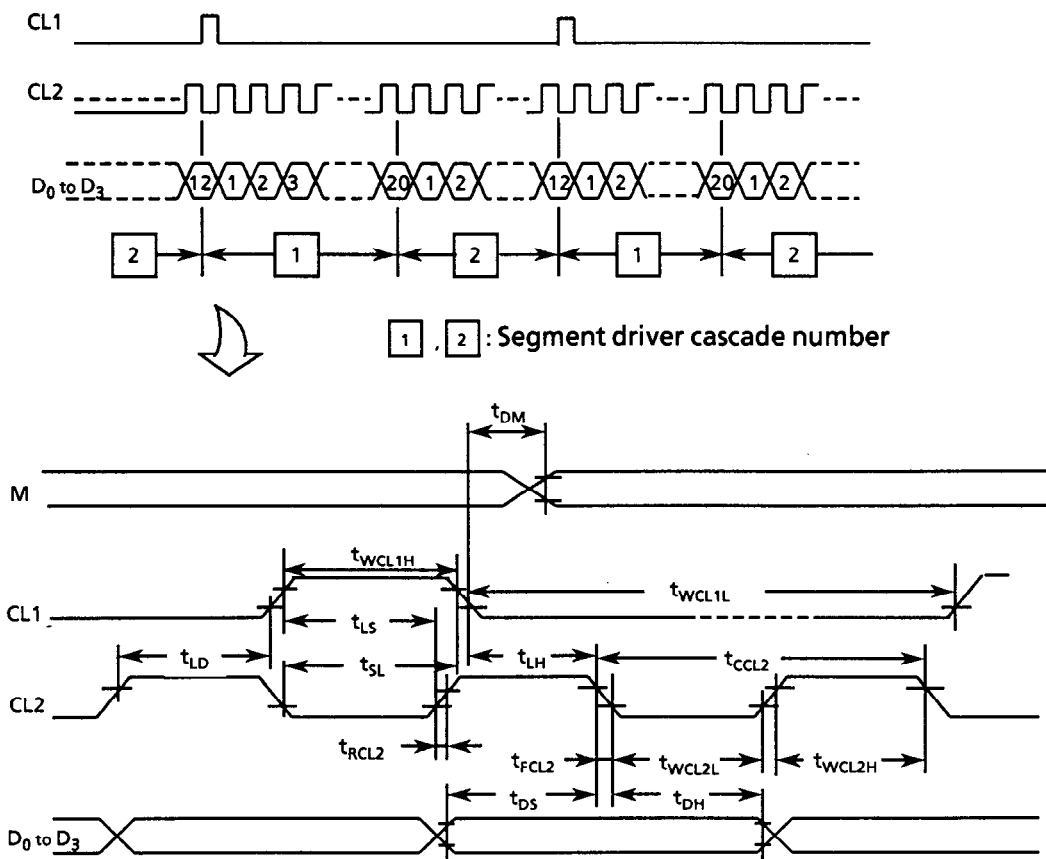

**Figure 11**



## 2.4 Interface Circuit

### 2.4.1 Interface with MPU signal

The G121C00P000 and the G121CBIP000 are controlled by the MPU circuit, whose interface is easily set up when the LCD controller is used. The LCD controller has basic functions such as receiving information related to the display from the MPU circuit, sending display timing signals and display data to the LCD module, as well as other functions such as cursor display.

The G121C must use an LCD controller conforming to the following:

- For a full dot-matrix LCD module
- Where data is transferred to the LCD module in four-bit parallel
- Where G121C display screen has 1/128 duty

The following section gives examples of interfaces using the Oki MSM6255GSK, Seiko Epson SED1330F/1335F, and Hitachi HD64646FS controllers.

(1) OKI MSM6255GSK

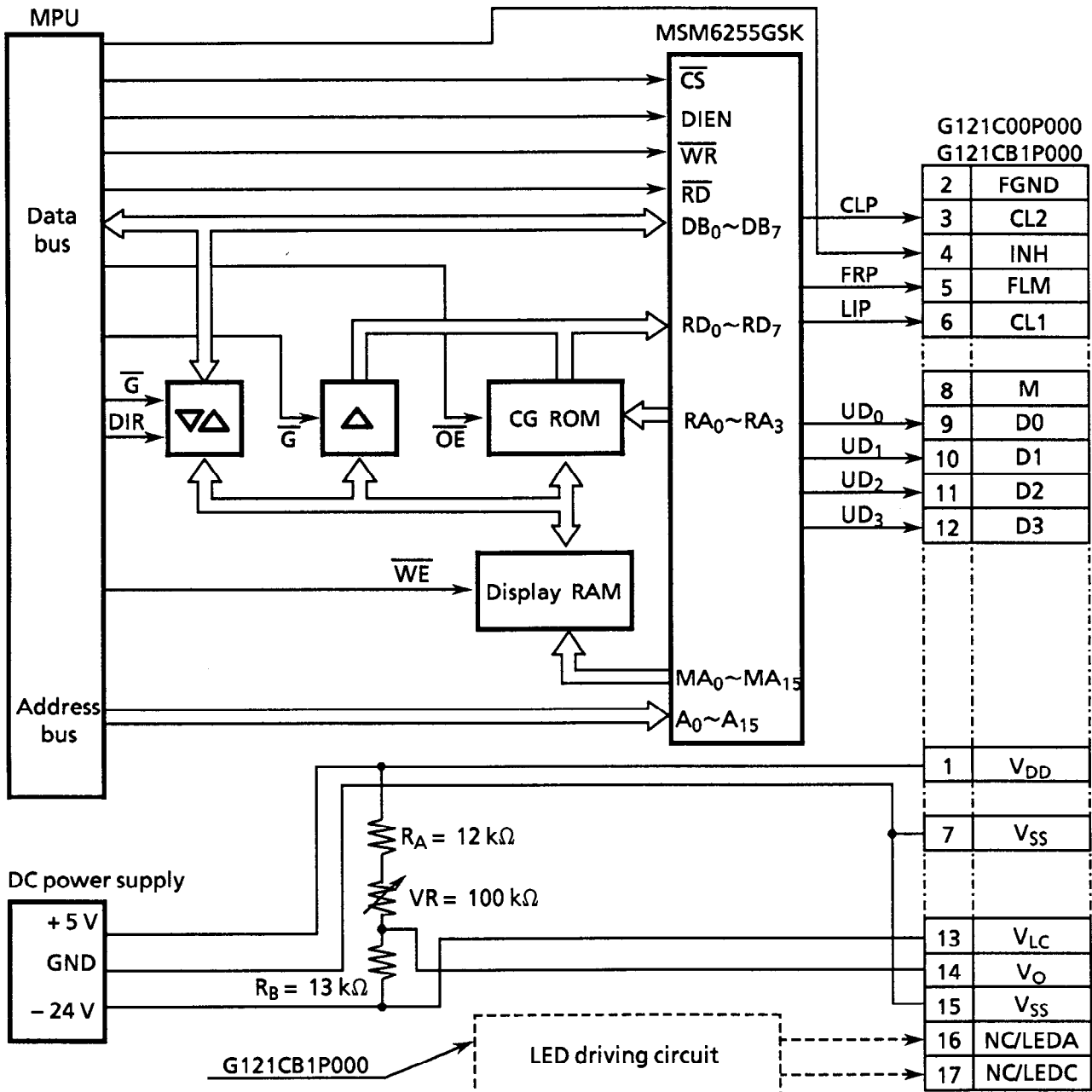

Figure 12 Interface Circuit With MSM6255GSK

Features of the MSM6255GSK:

- Interface with 80-series MPU possible
- Cursor
  - ON/OFF
  - Blinking speed, form, and position are programmable
- Scrolling and paging
- CMOS process
- Power supply voltage 5V ± 10%

(2) SEIKO EPSON SED1330F/1335F

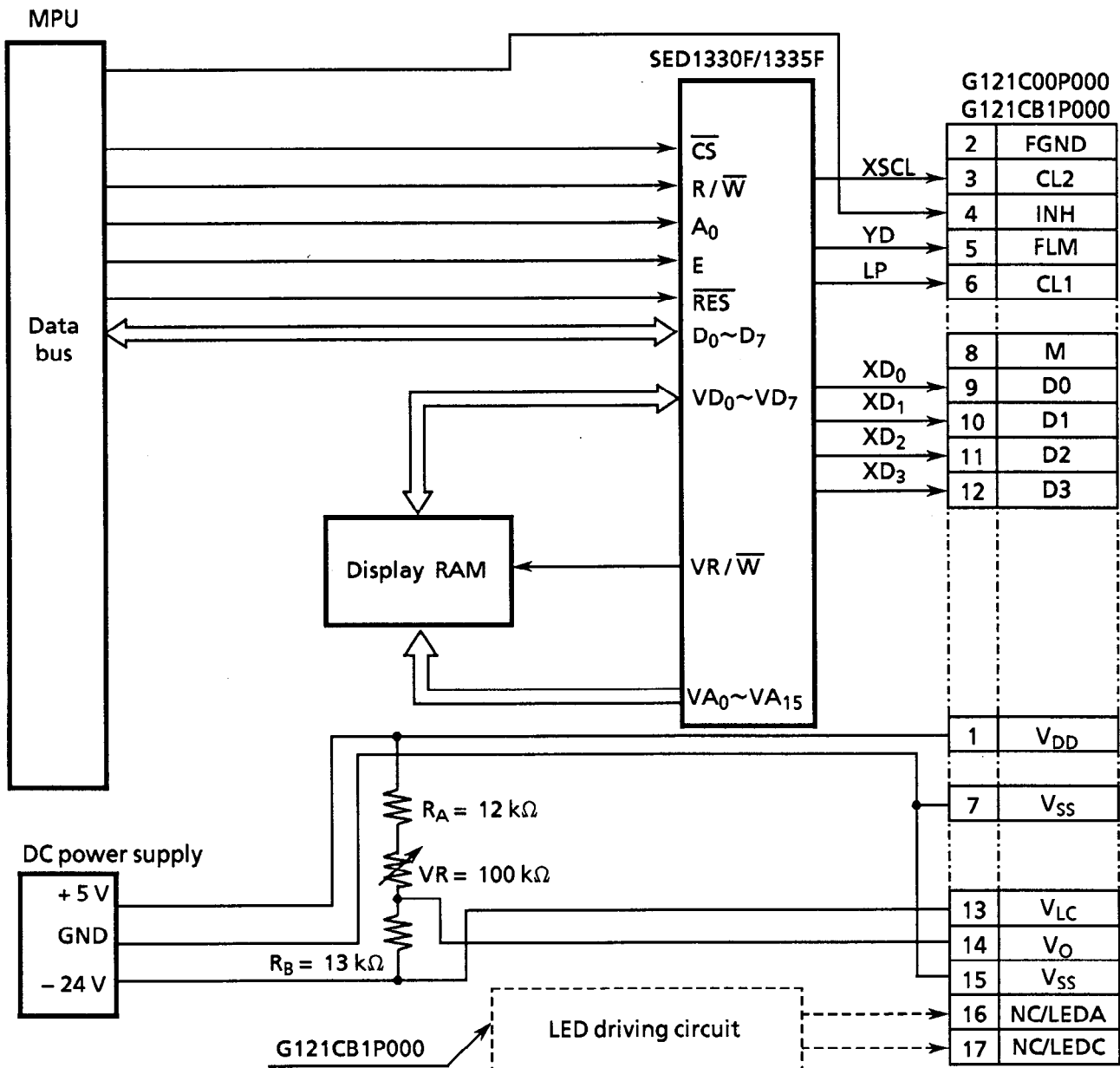

Figure 13 Interface Circuit With SED1330F/SED1335F

Features of the SED1330F/1335F:

- Interface with 80-series or 68-series MPU possible
- Built-in character generator ROM: 160 kinds
- External character generator
  - CG RAM : (8 × 16 dot matrix) × 64 kinds
  - CG ROM : (8 × 16 dot matrix) × 256 kinds
- Layered mode : AND, OR, XOR, "preferred" OR
- CMOS process
- Scrolling (vertical and horizontal)
- Power supply voltage 5 V ± 10% (SED1330F)

2.7 to 5.5 V (SED1335F)

## (3) HITACHI HD64646FS

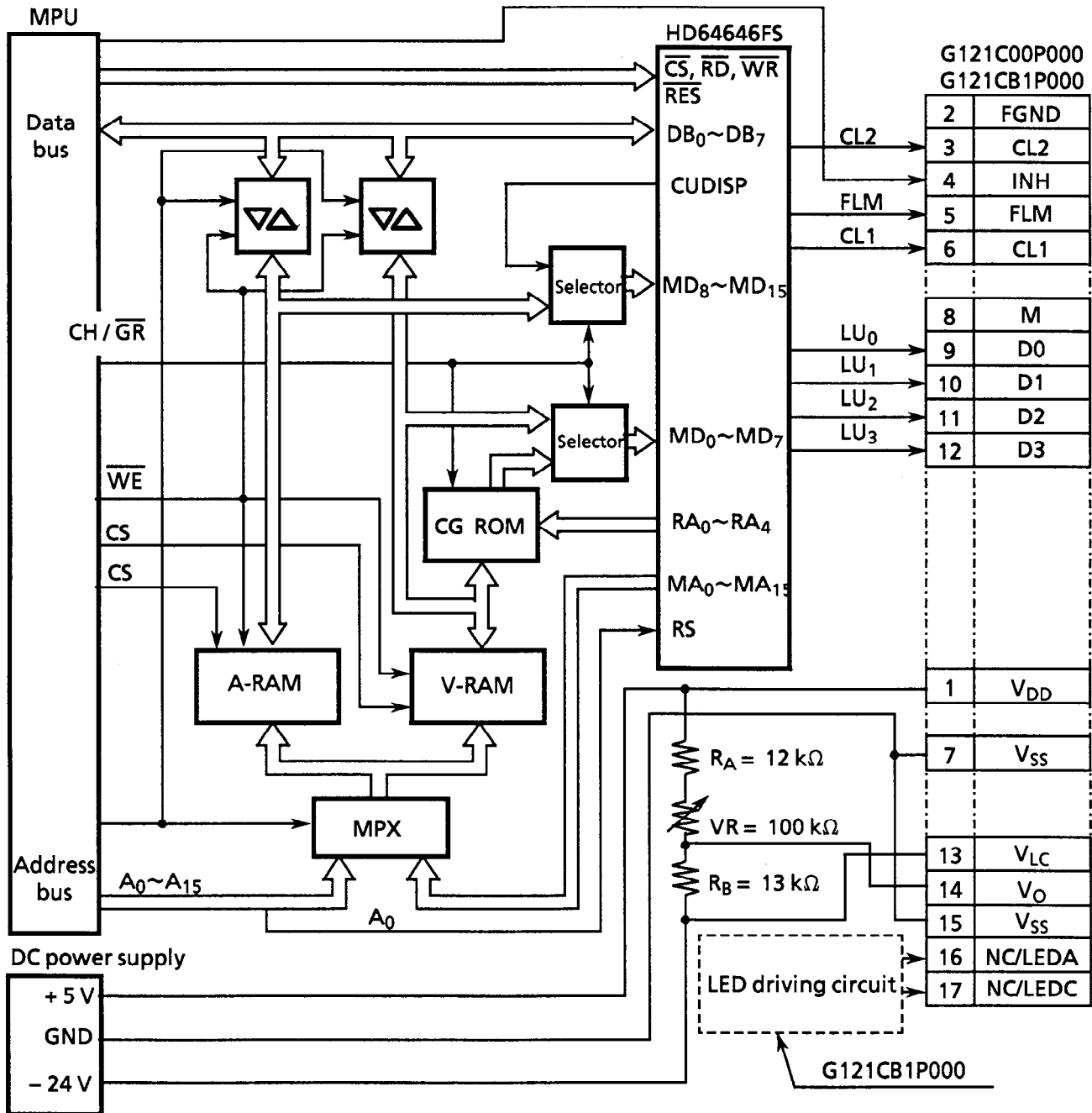

Figure 14 Interface Circuit With HD64646FS

## Features of the HD64646FS:

- Interface with 80-series MPU possible
- Layered mode : OR (character and graphics)
- Character reverse, blinking, all black, all white
- Cursor
  - ON/OFF
  - Blinking speed, form and position are programmable
- Character font
  - Vertical : 1 to 32 dots
  - Horizontal : 8 dots
- Scrolling
  - Vertical : smooth or character unit
  - Horizontal : character unit
- CMOS process
- Power supply voltage 5 V  $\pm$  10%

### 3. LED BACKLIGHT (G121CB1P000)

#### 3.1 Absolute Maximum Ratings

Item	Symbol	Standard	Unit
DC forward current	$I_F$	200*	mA
DC reverse voltage	$V_R$	8	V
Allowable dissipation	$P_D$	950	mW
Operating temp. range	$T_{opr}$	- 20 to + 70	°C
Storage temp. range	$T_{stg}$	- 30 to + 80	°C

\* Forward current reduction characteristics: The absolute maximum rating of the forward current varies depending on ambient temperature.

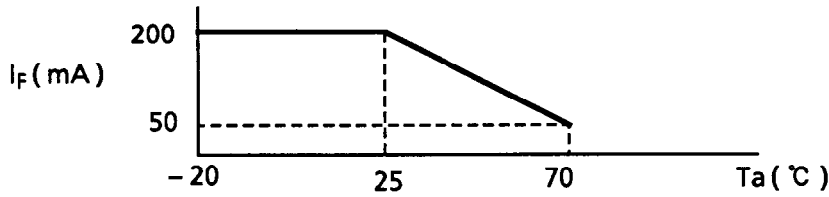

#### 3.2 Electrical and Optical Characteristics

$T_a = 25^\circ\text{C}$

Item	Symbol	Meas. condition	Min.	Typ.	Max.	Unit
Forward voltage	$V_F$	$I_F = 100 \text{ mA}$	3.7	4.1	4.5	V
Reverse current	$I_R$	$V_R = 8 \text{ V}$	-	-	300	$\mu\text{A}$

#### 3.3 LED Backlight Connection Diagram

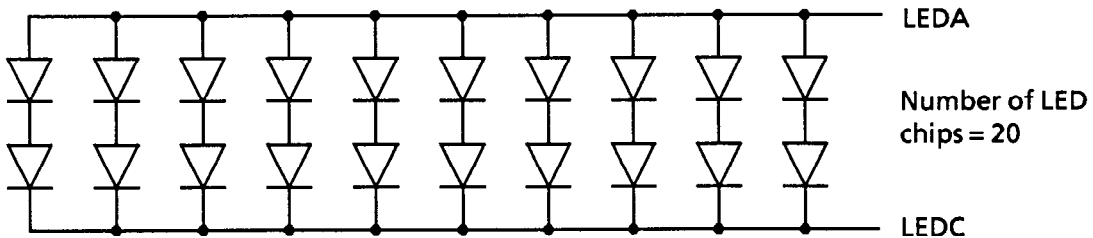

#### 3.4 Brightness (panel upper side)

Item	Symbol	Min.	Typ.	Max.	Unit
Surface brightness (Center of LCD panel)	$B_p$	1.0	1.7	-	nit

Measurement conditions and a measuring instrument are:

- $T_a = 25^\circ\text{C} \pm 3^\circ\text{C}$
- 30% to 85% RH
- $I_F = 100 \text{ mA}$
- $f_{FRM} = 70 \text{ Hz}$
- $V_{LC} = \text{Optimum LC drive voltage}$
- Display OFF (Entire display data = "L")
- Measured 30 minutes after LED lights
- Measuring instrument: BM - 7 (TOPCON)

### 3.5 Lifetime

Item	Measurement conditions	Standard	Unit
Lifetime*	Ta = 25°C ± 10°C I <sub>F</sub> = 100 mA	50,000 or more	hrs

\* Definition of lifetime: The time until the brightness decreases to half of the initial brightness.

### 3.6 Examples of LED Backlight Drivers

#### (1) Example 1

A basic LED backlight driver example is shown in Figure 15.

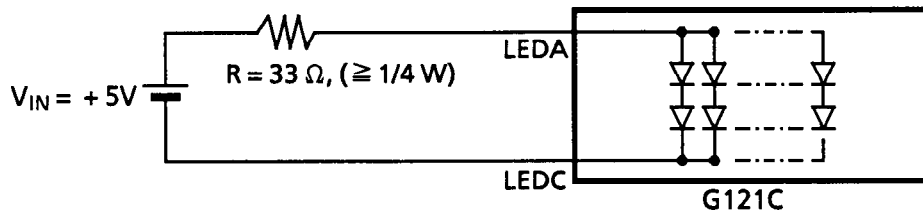

Figure 15 LED Backlight Driver Example 1

Where resistance “R” is the limit resistance of the LED forward current. The forward current depends upon the temperature. Especially, it must be decreased at high temperature. For temperature dependence, refer to forward current reduction characteristics described in 3.1. The operating temperature for the G121C ranges from – 20°C to + 70°C. It is necessary to determine limit resistance “R” so that the forward current becomes 50 mA or lower at + 70°C.

Forward voltage V<sub>F</sub> at each temperature of the LED backlight is shown in Table 5.

Table 5 Forward Voltage At Temperatures

Temperature (Ta)	Conditions	V <sub>F</sub> min.	V <sub>F</sub> typ.	V <sub>F</sub> max.
– 20°C	I <sub>F</sub> = 100 mA	3.9 V	4.3 V	4.7 V
+ 25°C	I <sub>F</sub> = 100 mA	3.7 V	4.1 V	4.5 V
+ 70°C	I <sub>F</sub> = 50 mA	3.4 V	3.6 V	3.9 V

Limit resistance “R” is calculated using the following equation. The resistance becomes the value shown in Figure 15.

$$R = \frac{V_{IN} - V_F}{I_F} \quad (\Omega)$$

V<sub>IN</sub> = Input voltage (power voltage)(V)  
 V<sub>F</sub> = LED forward voltage (V)  
 I<sub>F</sub> = Allowable LED forward current (A)

For this resistance value, the forward current becomes lower than 50 mA at 25°C. The surface brightness of the LED backlight varies with the forward current. See Figure 16. Compared with 3.4 brightness (I<sub>F</sub> = 100 mA), the brightness is about 30%.

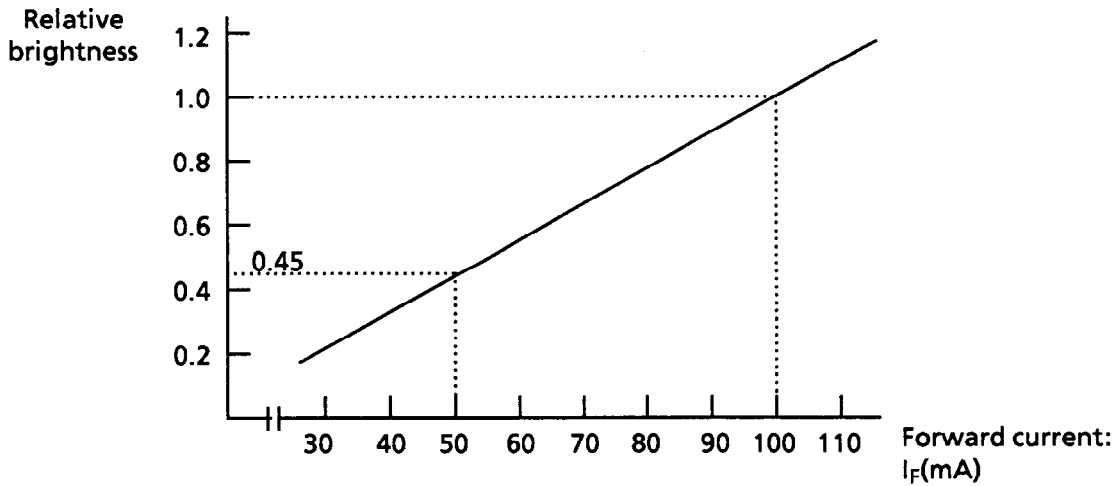

Figure 16 Forward Current-Brightness Characteristics ( $T_a = 25^\circ\text{C}$ )

(2) Example 2

When you want to keep the brightness (2 nit) at  $25^\circ\text{C}$ , use a thermosensitive element, like a thermistor, and a transistor as shown in Figure 17. Set the thermosensitive element to about  $I_F = 100\text{ mA}$  at  $25^\circ\text{C}$  and configure it so that " $I_F$ " will be reduced as the temperature rises.

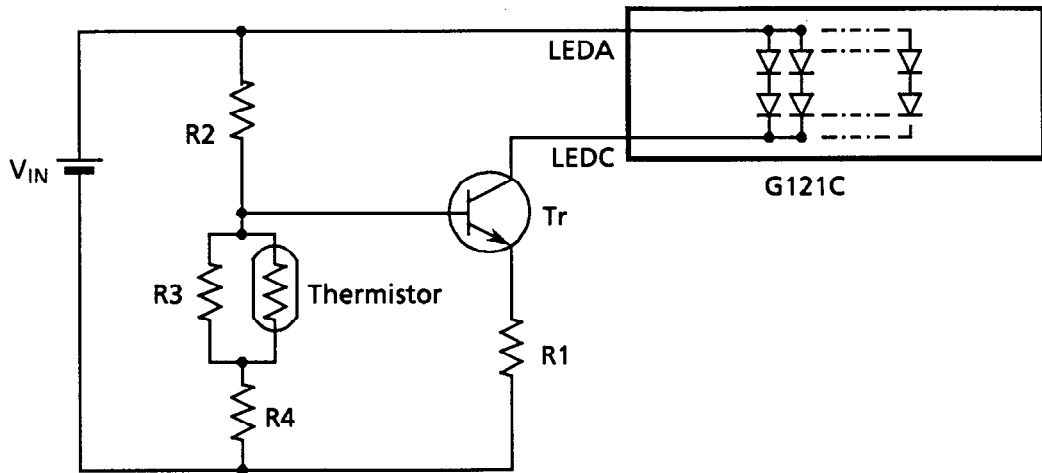

Figure 17 LED Backlight Driver Example 2

## 4. PRECAUTIONS

### Safety

- If the LCD panel is damaged, be careful not to get the liquid crystal in your mouth and not to be injured by crushed glasses.
- If you should swallow the liquid crystal, first, wash your mouth thoroughly with water, then, drink a lot of water and induce vomiting; and then, consult a physician.
- If the liquid crystal should get in your eye, flush your eye with running water for at least fifteen minutes.
- If the liquid crystal touches your skin or clothes, remove it and wash the affected part of your skin or clothes with soap and running water.
- Use the LCD module within the rated voltage to prevent overheating and/or damage. Also, take steps to ensure that the connector does not come off.

### Handling

- Avoid static electricity, as it will damage the CMOS LSI.
- The LCD panel is made of plate glass. Do not hit, crush, or bend it.
- Do not remove the panel or frame from the module.
- The polarizer of the display is very fragile. Handle it with care.

### Mounting and design

- Mount the module using the specified mounting parts and holes.
- To protect the module against external pressure, place a transparent plate (e.g., acrylic or glass) on the module, leaving a small gap between the display surface and transparent plate.

☆ Example

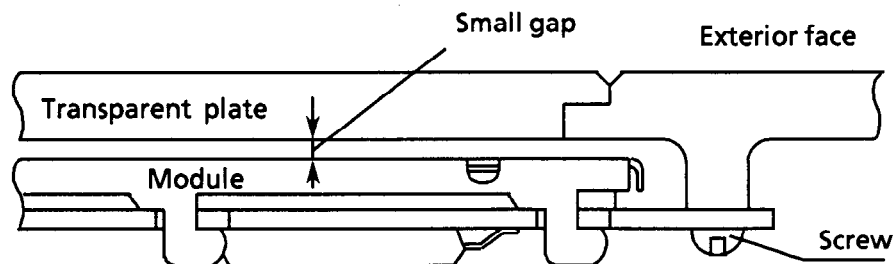

- Keep the module dry. Avoid condensation to prevent the transparent electrodes from being damaged.

### Storage

- Store the module in a dark place, where the temperature is  $25\text{ }^{\circ}\text{C} \pm 10\text{ }^{\circ}\text{C}$  and the relative humidity is below 65%.
- Do not store the module near organic solvents or corrosive gases.
- Keep the module (including accessories) safe from vibration, mechanical shock and external pressure.
- Black or white air-bubbles may be produced if the module is stored for a long time in the lower temperature or mechanical shocks are applied onto the module.

### Cleaning

- Do not wipe the polarizer with a dry cloth, as it may scratch the surface.
- Wipe the module gently with a soft cloth soaked with a petroleum benzene.
- Do not use ketonic (ketone) solvents (ketone and acetone) or aromatic solvents (toluene and xylene), as they may damage the polarizer.



## Index

<b>-A-</b>	Allowable dissipation .....	18
<b>-B-</b>	Bias value .....	6
	Bias voltage generation circuit .....	8, 11
	Block diagram .....	8
	Brightness .....	18, 19, 20
<b>-C-</b>	Chip enable function .....	9
	Cleaning .....	21
	Common drive waveform .....	9
	Common driver .....	8, 9, 13
	Contrast .....	3, 4
	Current consumption .....	2
<b>-D-</b>	Definition of contrast .....	4
	Definition of response time .....	4
	Definition of viewing angles .....	4
	Display data input .....	5
	Display data shift clock .....	2, 5, 9
	Display ON/OFF control terminal .....	5
	Drive waveform .....	6, 7
<b>-E-</b>	Effective voltage .....	6
<b>-F-</b>	Flicker .....	6
	Forward current .....	18, 19
	Forward current reduction characteristics .....	18, 19
	Forward voltage .....	18, 19
	Frame frequency .....	2, 4, 6
	Frame ground .....	5
<b>-H-</b>	HITACHI HD64646FS .....	14, 17
<b>-I-</b>	Input voltage .....	1, 2
	Interface .....	14
	I/O terminal functions .....	4

<b>-L-</b>	LCD controller .....	14
	Life time .....	4, 19
	Limit resistance .....	19
	Liquid crystal drive voltage adjustment terminal .....	5
	Liquid crystal AC drive control signal .....	6, 9, 11
	Liquid crystal operating voltage .....	10
<b>-M-</b>	M' generation circuit .....	8, 11
<b>-N-</b>	Non-selection waveform .....	5, 6
<b>-O-</b>	OKI MSM6255GSK .....	14, 15
	One-common-line timing signal .....	5, 9, 11
	One-frame timing signal .....	5, 9, 11
	Operating temperature .....	2, 18
	Operational amplifier .....	10, 11
<b>-P-</b>	Positive display .....	1
	Power supply voltage .....	2, 15, 16, 17
<b>-R-</b>	Resistance division .....	11
	Response time (fall) .....	4
	Response time (rise) .....	4
	Reverse current .....	18, 19
	Reverse voltage .....	18, 19
<b>-S-</b>	Segment drive waveform .....	9
	Segment driver .....	8, 9, 13
	SEIKO EPSON SED1330F/1335F .....	14, 16
	Selection waveform .....	6, 7
	Storage .....	21
	Storage humidity .....	2
	Storage temperature .....	2, 18
<b>-T-</b>	Timing characteristics .....	12
<b>-V-</b>	Viewing angle .....	3
	V <sub>opr</sub> control circuit .....	8, 10

## **Seiko Instruments Inc.**

### **Head Office**

Components Sales Department  
1-8, Nakase, Mihama-ku, Chiba-shi, Chiba 261, Japan  
Phone: 043-211-1216 FAX: 043-211-8035

### **Seiko Instruments U.S.A. Inc.**

Electronic Components Division  
2990 W. Lomita Blvd., Torrance Calif. 90505, USA Phone: 310-517-7770 FAX: 310-517-7792

### **Seiko Instruments GmbH**

Siemensstrasse 9b, 63263 Neu-Isenburg, Germany Phone: 49-6102-297-0 FAX: 49-6102-297-222

### **Seiko Instruments (H. K.) Ltd. Sales Division**

4-5/F, Wyler Centre 2, 200 Tai Lin Pai Road, Kwai Chung, N.T., Kowloon, Hong Kong  
Phone: 852-24218611 FAX: 852-24805479

### **Seiko Instruments Taiwan Inc.**

5F-1 No. 99, SEC.2, Chung Shan N. Rd., Taipei 104, Taiwan, R.O.C.  
Phone: 886-2-563-5001 FAX: 886-2-521-9519

### **Seiko Instruments Singapore Pte. Ltd**

2, Marsiling Lane Woodland New Town Singapore 2573  
Phone: 65-2691370 FAX: 65-2699729