



LIGITEK ELECTRONICS CO.,LTD.
Property of Ligitek Only

SURFACE MOUNT LED TAPE AND REEL



Lead-Free Parts

LHROS9S53-HC-T20

DATA SHEET

DOC. NO : QW0905-LHROS9S53-HC-T20

REV. : A

DATE : 25 - Apr. - 2014



Features:

1. Top view LED.
2. White SMT package.
3. Leadframe package with individual 2 pin.
4. Wide viewing angle.
5. Soldering methods: IR reflow soldering.
6. Feature of the device: more light due to higher optical efficiency; extremely wide viewing angle; ideal for backlighting and coupling in light guide.
7. Qualification according to AEC-Q101

Descriptions:

The LHROS9S53 SMD has wide viewing angle and optimized light coupling by inter reflector, The low current requirement makes this device ideal for portable equipment or any other application where power is at a premium.

Applications:

1. Telecommunication: indicator and backlighting in telephone and fax.
2. Indicators.
3. Switch lights.
4. Automotive backlighting or indicator.

Device Selection Guide:

| PART NO | MATERIAL | COLOR | |
|------------------|----------|---------|-------------|
| | | Emitted | Lens |
| LHROS9S53-HC-T20 | AlGaInP | Red | Water Clear |

Package Dimensions

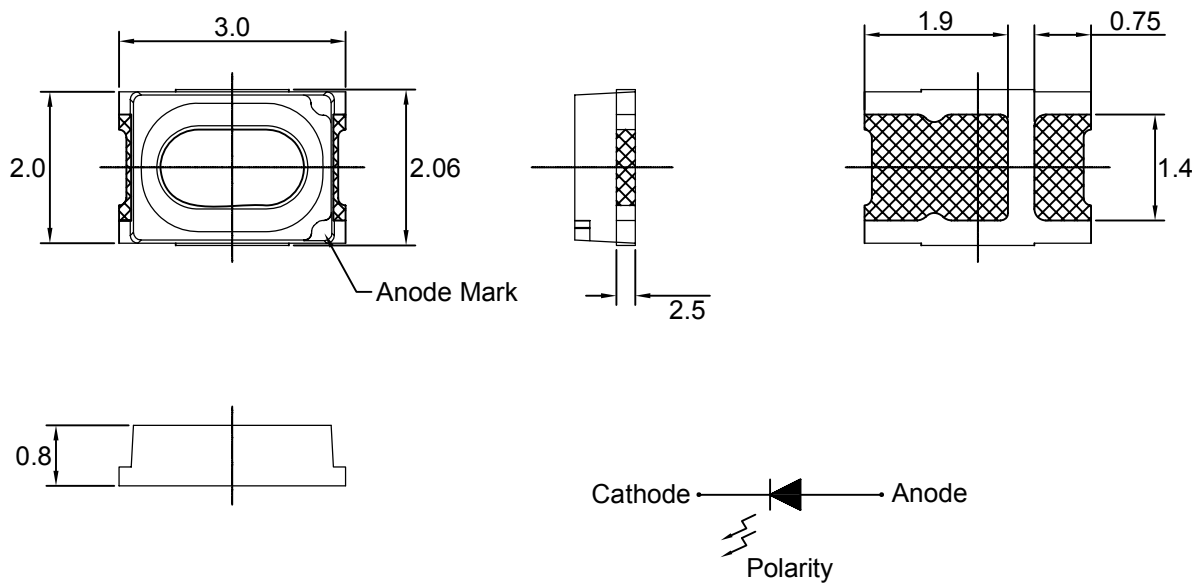

Note : 1.All dimension are in millimeter tolerance is $\pm 0.2\text{mm}$ unless otherwise noted.
2.Specifications are subject to change without notice.

Recommended Soldering Pad Dimensions

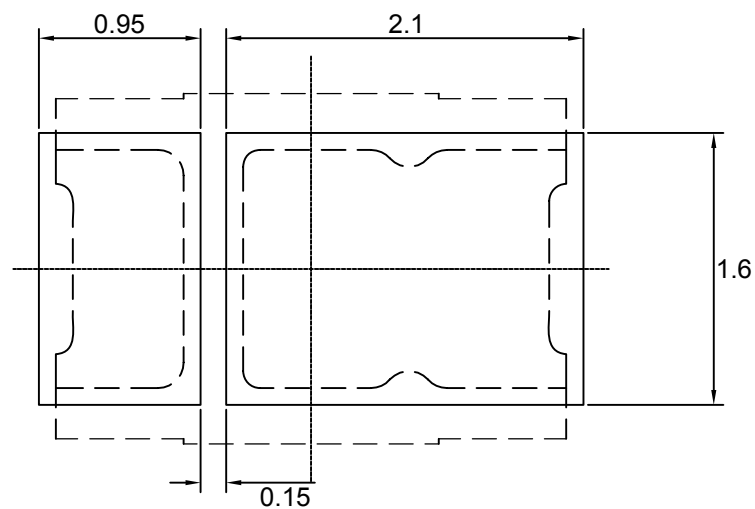

Note : The tolerances unless mentioned is $\pm 0.1\text{mm}$, Unit=mm.

Absolute Maximum Ratings at Ta=25 °C

| Parameter | Symbol | Ratings | UNIT |
|---|---------|--------------|------|
| Forward Current | IF | 50 | mA |
| Peak Forward Current Duty 1/10@10KHz | IFP | 100 | mA |
| Power Dissipation | PD | 130 | mW |
| Reverse Current @5V | Ir | 10 | μA |
| Electrostatic Discharge | ESD | 2000 | V |
| Operating Temperature | Topr | - 40 ~ + 85 | °C |
| Storage Temperature | Tstg | - 40 ~ + 100 | °C |
| Junction Temperature | Tj | 115 | °C |
| Thermal resistance | Rth j-s | 300 | °K/W |
| | Rth j-a | 500 | °K/W |

Typical Electrical & Optical Characteristics (Ta=25 °C)

| Items | Symbol | Min. | Typ. | Max. | UNIT | CONDITION |
|--------------------------|----------------|------|------|------|------|-----------|
| Luminous Intensity | Iv | 500 | 800 | ---- | mcd | IF=20mA |
| Dominant Wavelength | λD | ---- | 630 | ---- | nm | IF=20mA |
| Spectral Line Half-Width | Δλ | ---- | 20 | ---- | nm | IF=20mA |
| Forward Voltage | V _F | 1.7 | ---- | 2.6 | V | IF=20mA |
| Viewing Angle | 2θ 1/2 | ---- | 120 | ---- | deg | IF=20mA |

Note : 1.The forward voltage data did not including ±0.1V testing tolerance.
2.The luminous intensity data did not including ±15% testing tolerance.
3.The dominant wavelength data did not including ±1nm testing tolerance

Luminous Intensity Classification

| BIN CODE | Iv(mcd) at 20mA | |
|----------|-----------------|------|
| | Min. | Max. |
| U | 500 | 800 |
| V-1 | 800 | 1000 |
| V-2 | 1000 | 1250 |
| W-1 | 1250 | 1600 |

Typical Electro-Optical Characteristics Curve

HROS CHIP

Fig.1 Forward current vs. Forward Voltage

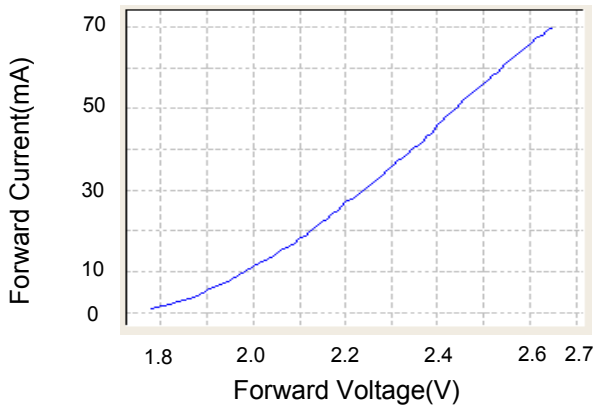

Fig.2 Relative Intensity vs. Forward Current

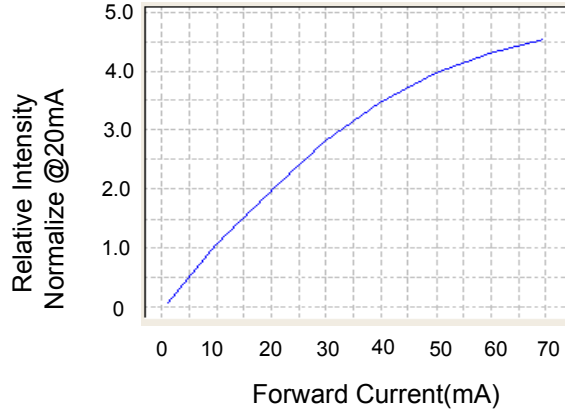

Fig.3 Forward Voltage vs. Temperature

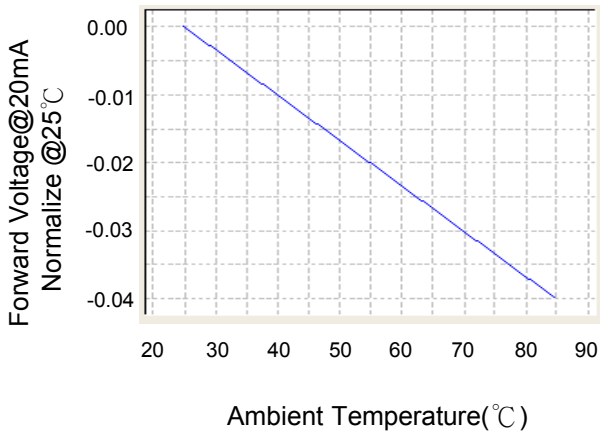

Fig.4 Relative Intensity vs. Temperature

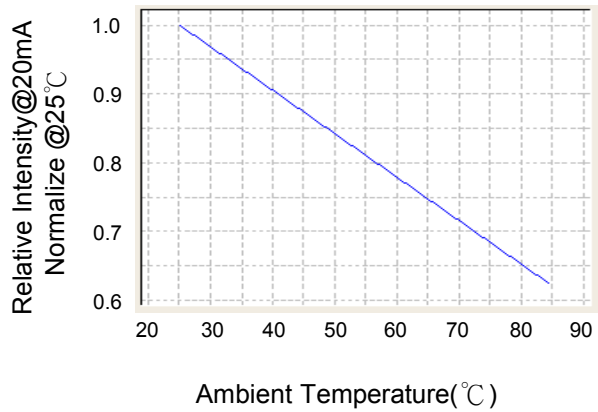

Fig.5 Relative Intensity vs. Wavelength

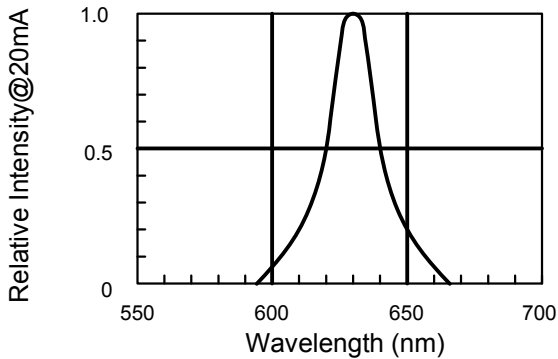

Fig.6 Forward Current vs. Temperature

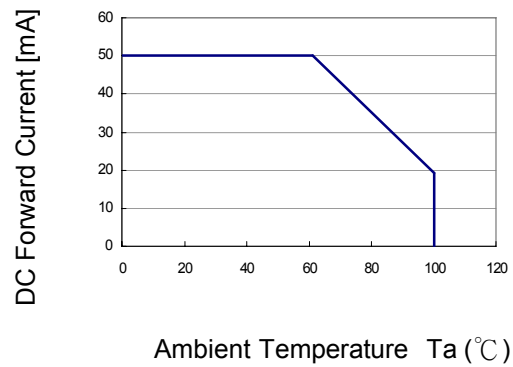
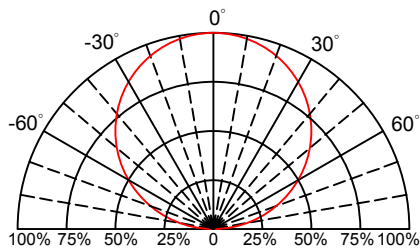
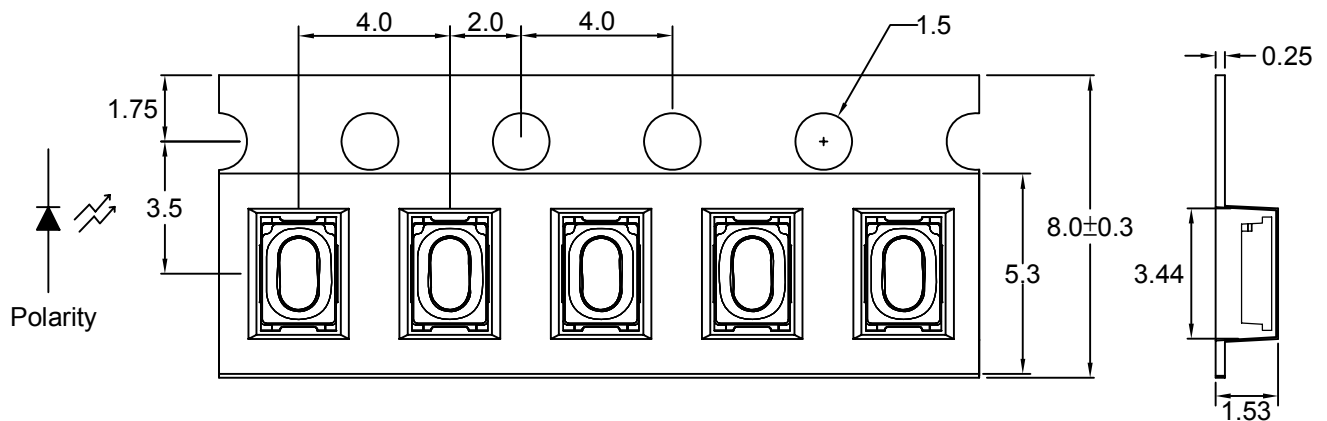

Fig.7 Directive Radiation



Carrier Type Dimensions







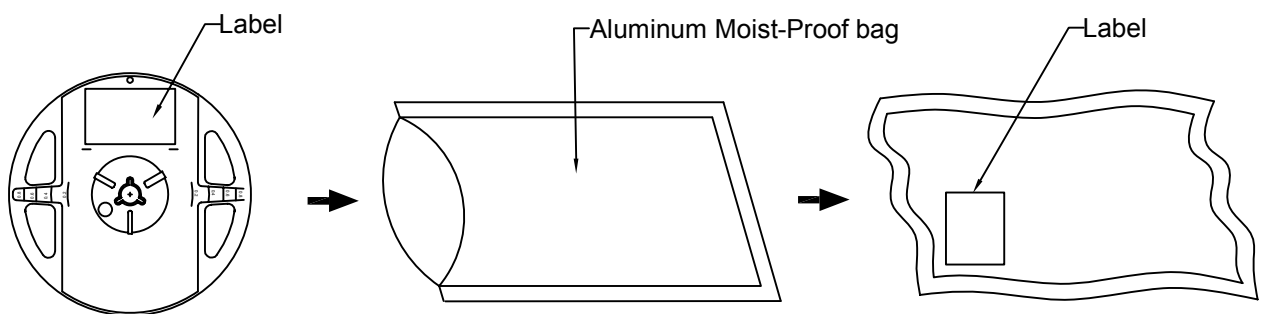

Note : The tolerances unless mentioned is $\pm 0.1\text{mm}$, Unit=mm.

• Packing Specifications



| Part No. | Description | Quantity/Reel |
|------------------|------------------------------------|---------------|
| LHROS9S53-HC-T20 | 8.0mm tape, $\varnothing 7''$ reel | 2000 PCS |

Label Explanation

| | | |
|---|---|---|
|  | LIGITEK ELECTRONICS CO., LTD. | |
| PART : |  | |
| | LHR0S9S53-HC-T20 | |
| LOT : |  | |
| | GS11440168 | |
| QTY(PCS): |  | |
| | 2000 | |
| BIN/HUE : |  |  |
| | V-1 | VF:1.7-2.6 |

BIN : Luminous Intensity

HUE : Dominant Wavelength

VF : Forward Voltage

Reel Dimensions

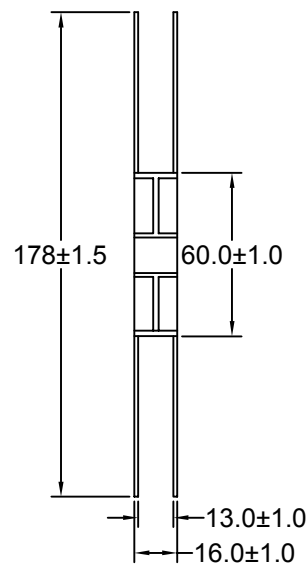
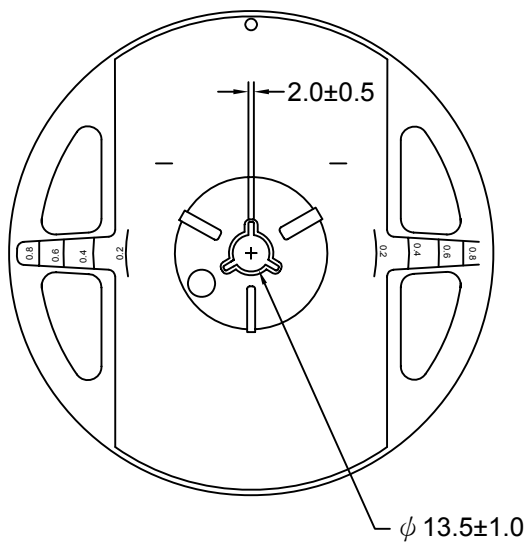

Box Explanation

1. 5 BAG / INNER BOX

2. INNER BOX SIZE : L X W X H 23cm X 8.5cm x 26cm

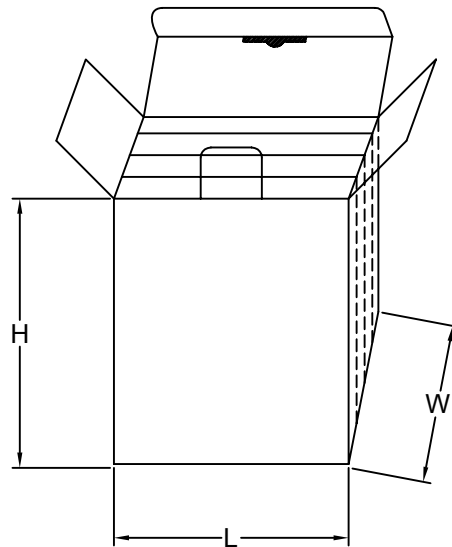

3. 10 INNER BOXES / CARTON

4. CARTON SIZE : L X W X H 58cm X 34cm x 35cm

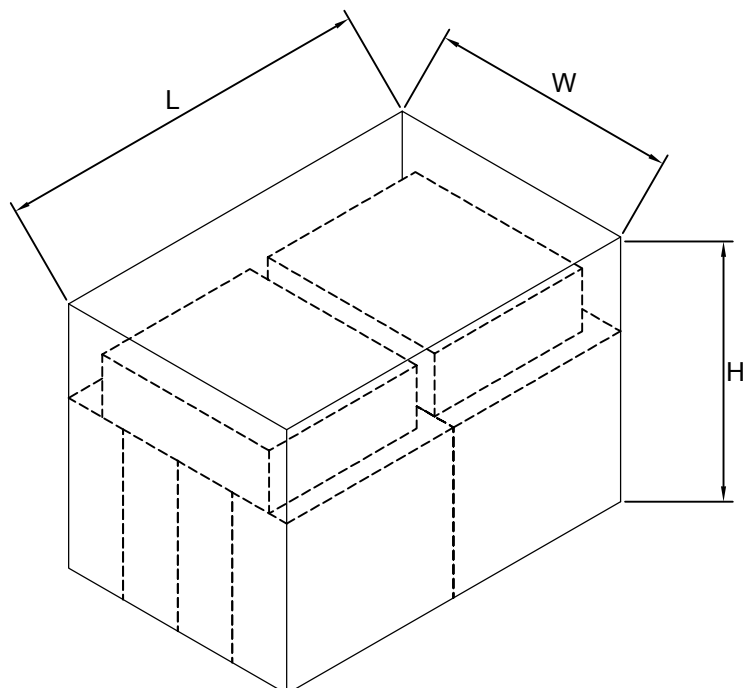

Recommended Soldering Conditions**1. Hand Solder**

Basic spec is $\leq 320^{\circ}\text{C}$ 3 sec one time only.

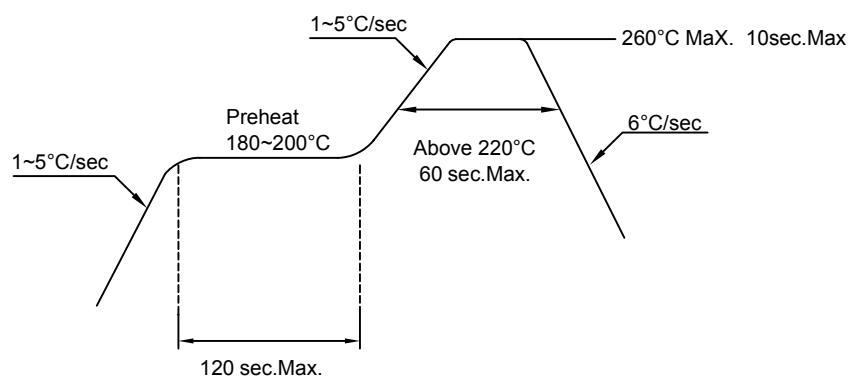
3. PB-Free Reflow Solder**Note:**

- 1.Reflow soldering should not be done more than two times.
- 2.When soldering,do not put stress on the LEDs during heating.
- 3.After soldering,do not warp the circuit board.

Precautions For Use:**Storage time:**

- 1.The operation of Temperatures and RH are : $5^{\circ}\text{C}\sim 35^{\circ}\text{C}$,RH60%.
- 2.Once the package is opened, the products should be used within a week.
Otherwise, they should be kept in a damp proof box with desiccating agent.
Considering the tape life, we suggest our customers to use our products within a year(from production date).
- 3.If opened more than one week in an atmosphere $5^{\circ}\text{C} \sim 35^{\circ}\text{C}$,RH60%, they should be treated at $60^{\circ}\text{C}\pm 5^{\circ}\text{C}$ for 15hrs.

Drive Method:

LED is a current operated device, and therefore, requires some kind of current limiting incorporated into the driver circuit. This current limiting typically takes the form of a current limiting resistor placed in series with the LED.

Consider worst case voltage variations that could occur across the current limiting resistor. The forward current should not be allowed to change by more than 40% of its desired value.

Circuit model A

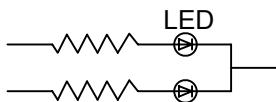

Circuit model B

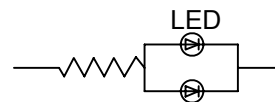

(A) Recommended circuit.

(B) The difference of brightness between LED could be found due to the VF-IF characteristics of LED.

Cleaning:

Use alcohol-based cleaning solvents such as isopropyl alcohol to clean the LED.

ESD(Electrostatic Discharge):

Static Electricity or power surge will damage the LED. Use of a conductive wrist band or anti-electrostatic glove is recommended when handling these LED. All devices, equipment and machinery must be properly grounded.

Reliability Test:

(1)Test items and results

| Classification | Test Item | Test Condition | Sample Size |
|--------------------|---|--|-------------|
| Endurance Test | Operating Life Test | 1.Ta=Under Room Temperature As Per Data Sheet Maximum Rating. 2.If=20mA 3.t=1000 hrs | 22 |
| | High Temperature Storage Test | 1.Ta=105°C±5°C 2.t=500 hrs | 22 |
| | Low Temperature Storage Test | 1.Ta=-40°C±5°C 2.t=1000 hrs | 22 |
| | High Temperature High Humidity Storage Test | 1.IR-Reflow In-Board, 2 Times 2.Ta=85°C±5°C 3.RH=90%~95% 4.t=500hrs±2hrs | 22 |
| Environmental Test | Thermal Shock Test | 1.IR-Reflow In-Board,2 times 2.Ta=105°C ±5°C & -40°C ±5°C (30min) (30min) 3.total 100 cycles | 22 |
| | Reflow Soldering Test | 1.T.Sol=260°C ±5°C 2.Dwell Time= 10Max. | 22 |
| | Temperature Cycling | 1.105°C ~ 25°C ~ -40°C 30mins 15mins 30mins 2.100 Cyeles | 22 |

(2)Criteria for judging the damage

| Item | Symbol | Test Conditions | Criteria for Judgement | |
|--------------------|--------|-----------------|------------------------|------------|
| | | | Min. | Max. |
| Forward Voltage | Vf | If=20mA | - | U.S.L x1.2 |
| Reverse Current | Ir | Vr=5V | - | U.S.L x2.0 |
| Luminous Intensity | Iv | If=20mA | L.S.L x 0.5 | - |

Note:

1.U.S.L.:Upper Standard Level.

2.L.S.L.:Lower Standard Level.