

R1QEA4436RBG, R1QEA4418RBG

144-Mbit DDR™II+ SRAM 2-word Burst

R10DS0142EJ0200

Rev.2.00

Apr 01, 2014

Architecture (2.5 Cycle Read latency) with ODT

Description

The R1QEA4436RBG is a 4,194,304-word by 36-bit and the R1QEA4418RBG is a 8,388,608-word by 18-bit synchronous double data rate static RAM fabricated with advanced CMOS technology using full CMOS six-transistor memory cell. It integrates unique synchronous peripheral circuitry and a burst counter. All input registers are controlled by an input clock pair (K and /K) and are latched on the positive edge of K and /K. These products are suitable for applications which require synchronous operation, high speed, low voltage, high density and wide bit configuration. These products are packaged in 165-pin plastic FBGA package.

Features

- Power Supply
 - 1.8 V for core (V_{DD}), 1.4 V to VDD for I/O (V_{DDQ})
- Clock
 - Fast clock cycle time for high bandwidth
 - Two input clocks (K and /K) for precise DDR timing at clock rising edges only
 - Two output echo clocks (CQ and /CQ) simplify data capture in high-speed systems
 - Clock-stop capability with μ s restart
- I/O
 - Common data input/output bus
 - Pipelined double data rate operation
 - HSTL I/O
 - User programmable output impedance
 - PLL circuitry for wide output data valid window and future frequency scaling
 - Data valid pin (QVLD) to indicate valid data on the output
- Function
 - Two-tick burst for low DDR transaction size
 - Internally self-timed write control
 - Simple control logic for easy depth expansion
 - JTAG 1149.1 compatible test access port
- Package
 - 165 FBGA package (15 x 17 x 1.4 mm)

Part Number Definition

Column No.	0	1	2	3	4	5	6	7	8	9	10	11	-	12	13	14	15	16
Example	R	1	Q	E	A	4	4	3	6	R	B	G	-	1	8	I	B	0
The above part number is just example for 144M DDRII+ B2 x36 550MHz, 15x17mm PKG, Pb-free part.																		

No.	-	Comments	No.	-	Comments	No.	-	Comments	
0-1	R1	Renesas Memory Prefix	4	A	Vdd = 1.8 V				
2-3	Q2	QDR II B2 ^[*1] (L15) ^[*2]	5-6	36	Density = 36Mb	12-13	60	Frequency = 167MHz	
	Q3	QDR II B4 (L15)		72	Density = 72Mb		50	Frequency = 200MHz	
	Q4	DDR II B2 (L15)		44	Density = 144Mb		40	Frequency = 250MHz	
	Q5	DDR II B4 (L15)		88	Density = 288Mb		36	Frequency = 275MHz	
	Q6	DDR II B2 SIO ^[*3] (L15)	7-8	09	Data width = 9bit		33	Frequency = 300MHz	
	QA	QDR II+ B4 L25 ^[*2]		18	Data width = 18bit		30	Frequency = 333MHz	
	QB	DDR II+ B2 L25	9	36	Data width = 36bit		27	Frequency = 375MHz	
	QC	DDR II+ B4 L25		R	1st Generation		25	Frequency = 400MHz	
	QD	QDR II+ B4 L25 w/ODT ^[*4]		A	2nd Generation		22	Frequency = 450MHz	
	QE	DDR II+ B2 L25 w/ODT		B	3rd Generation		20	Frequency = 500MHz	
	QF	DDR II+ B4 L25 w/ODT		C	4th Generation		19	Frequency = 533MHz	
	QG	QDR II+ B4 L20		D	5th Generation		18	Frequency = 550MHz	
	QH	DDR II+ B2 L20		E	6th Generation		14	R	Commercial temp. Ta range = 0°C to 70°C
	QJ	DDR II+ B4 L20		F	7th Generation			I	Industrial temp. Ta range = -40°C to 85°C
	QK	QDR II+ B4 L20 w/ODT	10-11	BG	PKG= BGA 15x17 mm		15	A	Pb and Tray
	QL	DDR II+ B2 L20 w/ODT		BB	PKG= BGA 13x15 mm			B	Pb-free and Tray
QM	DDR II+ B4 L20 w/ODT			T	Pb and Tape&Reel				
QN	QDR II+ B2 L20			S	Pb-free and Tape&Reel				
QP	QDR II+ B2 L20 w/ODT								
-	-					16	0 to 9, A to Z or None	Renesas internal use	

Note1: [*1] B=Burst length (B2: Burst length=2, B4: Burst length=4)
[*2] L=Read Latency (L15: Read Latency = 1.5 cycle, L20: 2.0 cycle, L25: 2.5 cycle)
[*3] SIO=Separate I/O
[*4] ODT=On die termination

Note2: Package Marking Name
Pb parts: Marking Name = Part Number(0-14)
Pb-free parts: Marking Name = Part Number(0-14) + "PB-F"
(Example) R1QAA4436RBG-20R ----- Pb parts
R1QAA4436RBG-20R PB-F ----- Pb-free parts

Note3: Pb : RoHS Compliance Level = 5/6
Pb-free: RoHS Compliance Level = 6/6

Note4: R1Q*A series support both "Commercial" and "Industrial" temperatures
by "Industrial" temperature parts.

Part Number Information

Ordering part number	Organization (word x bit)	Cycle time	Clock frequency	Operating Ambient Temperature	Core Supply Voltage (V)	Package
R1QEA4436RBG-18IA0	4M x 36	1.810ns	550MHz	T _A = -40 to 85°C	1.8 ± 0.1	165-pin PLASTIC BGA (15 x 17) Pb
R1QEA4436RBG-19IA0		1.875ns	533MHz			
R1QEA4436RBG-20IA0		2.00ns	500MHz			
R1QEA4418RBG-18IA0	8M x 18	1.810ns	550MHz			
R1QEA4418RBG-19IA0		1.875ns	533MHz			
R1QEA4418RBG-20IA0		2.00ns	500MHz			
R1QEA4436RBG-18IB0	4M x 36	1.810ns	550MHz	T _A = -40 to 85°C	1.8 ± 0.1	165-pin PLASTIC BGA (15 x 17) Pb-free
R1QEA4436RBG-19IB0		1.875ns	533MHz			
R1QEA4436RBG-20IB0		2.00ns	500MHz			
R1QEA4418RBG-18IB0	8M x 18	1.810ns	550MHz			
R1QEA4418RBG-19IB0		1.875ns	533MHz			
R1QEA4418RBG-20IB0		2.00ns	500MHz			

Pin Arrangement

[R1QEA4436RBG]

4M x 36

(Top View)

	1	2	3	4	5	6	7	8	9	10	11
A	/CQ	SA	SA	R-/W	/BW2	/K	/BW1	/LD	SA	SA	CQ
B	NC	DQ27	DQ18	SA	/BW3	K	/BW0	SA	NC	NC	DQ8
C	NC	NC	DQ28	VSS	SA	NC	SA	VSS	NC	DQ17	DQ7
D	NC	DQ29	DQ19	VSS	VSS	VSS	VSS	VSS	NC	NC	DQ16
E	NC	NC	DQ20	VDDQ	VSS	VSS	VSS	VDDQ	NC	DQ15	DQ6
F	NC	DQ30	DQ21	VDDQ	VDD	VSS	VDD	VDDQ	NC	NC	DQ5
G	NC	DQ31	DQ22	VDDQ	VDD	VSS	VDD	VDDQ	NC	NC	DQ14
H	/DOFF	VREF	VDDQ	VDDQ	VDD	VSS	VDD	VDDQ	VDDQ	VREF	ZQ
J	NC	NC	DQ32	VDDQ	VDD	VSS	VDD	VDDQ	NC	DQ13	DQ4
K	NC	NC	DQ23	VDDQ	VDD	VSS	VDD	VDDQ	NC	DQ12	DQ3
L	NC	DQ33	DQ24	VDDQ	VSS	VSS	VSS	VDDQ	NC	NC	DQ2
M	NC	NC	DQ34	VSS	VSS	VSS	VSS	VSS	NC	DQ11	DQ1
N	NC	DQ35	DQ25	VSS	SA	SA	SA	VSS	NC	NC	DQ10
P	NC	NC	DQ26	SA	SA	QVLD	SA	SA	NC	DQ9	DQ0
R	TDO	TCK	SA	SA	SA	ODT	SA	SA	SA	TMS	TDI

- Notes:
1. Address expansion order for future higher density SRAMs: 10A → 2A → 7A → 5B.
 2. NC pins can be left floating or connected to 0V to V_{DDQ}

[R1QEA4418RBG]

8M x 18

(Top View)

	1	2	3	4	5	6	7	8	9	10	11
A	/CQ	SA	SA	R-/W	/BW1	/K	SA	/LD	SA	SA	CQ
B	NC	DQ9	NC	SA	NC	K	/BW0	SA	NC	NC	DQ8
C	NC	NC	NC	VSS	SA	NC	SA	VSS	NC	DQ7	NC
D	NC	NC	DQ10	VSS	VSS	VSS	VSS	VSS	NC	NC	NC
E	NC	NC	DQ11	VDDQ	VSS	VSS	VSS	VDDQ	NC	NC	DQ6
F	NC	DQ12	NC	VDDQ	VDD	VSS	VDD	VDDQ	NC	NC	DQ5
G	NC	NC	DQ13	VDDQ	VDD	VSS	VDD	VDDQ	NC	NC	NC
H	/DOFF	VREF	VDDQ	VDDQ	VDD	VSS	VDD	VDDQ	VDDQ	VREF	ZQ
J	NC	NC	NC	VDDQ	VDD	VSS	VDD	VDDQ	NC	DQ4	NC
K	NC	NC	DQ14	VDDQ	VDD	VSS	VDD	VDDQ	NC	NC	DQ3
L	NC	DQ15	NC	VDDQ	VSS	VSS	VSS	VDDQ	NC	NC	DQ2
M	NC	NC	NC	VSS	VSS	VSS	VSS	VSS	NC	DQ1	NC
N	NC	NC	DQ16	VSS	SA	SA	SA	VSS	NC	NC	NC
P	NC	NC	DQ17	SA	SA	QVLD	SA	SA	NC	NC	DQ0
R	TDO	TCK	SA	SA	SA	ODT	SA	SA	SA	TMS	TDI

- Notes: 1. Address expansion order for future higher density SRAMs: 10A → 2A → 7A → 5B.
 2. NC pins can be left floating or connected to 0V to V_{DDQ}

Pin Descriptions

Name	I/O type	Descriptions	Note
SA	Input	Synchronous address inputs: These inputs are registered and must meet the setup and hold times around the rising edge of K. These inputs are ignored when device is deselected.	
/LD	Input	Synchronous load: This input is brought low when a bus cycle sequence is to be defined. This definition includes address and READ/WRITE direction.	
R-/W	Input	Synchronous read / write Input: When /LD is low, this input designates the access type (READ when R-/W is high, WRITE when R-/W is low) for the loaded address. R-/W must meet the setup and hold times around the rising edge of K.	
/BWx	Input	Synchronous byte writes: When low, these inputs cause their respective byte to be registered and written during WRITE cycles. These signals are sampled on the same edge as the corresponding data and must meet setup and hold times around the rising edges of K and /K for each of the rising edge comprising the WRITE cycle. See Byte Write Truth Table for signal to data relationship.	
K, /K	Input	Input clock: This input clock pair registers address and control inputs on the rising edge of K, and registers data on the rising edge of K and the rising edge of /K. /K is ideally 180 degrees out of phase with K. All synchronous inputs must meet setup and hold times around the clock rising edges. These balls cannot remain V_{REF} level.	
/DOFF	Input	PLL disable: When low, this input causes the PLL to be bypassed for stable, low frequency operation.	
TMS TDI	Input	IEEE1149.1 test inputs: 1.8 V I/O levels. These balls may be left unconnected if the JTAG function is not used in the circuit.	
TCK	Input	IEEE1149.1 clock input: 1.8 V I/O levels. This ball must be tied to V_{SS} if the JTAG function is not used in the circuit.	
ZQ	Input	Output impedance matching input: This input is used to tune the device outputs to the system data bus impedance. DQ and CQ output impedance are set to $0.2 \times RQ$, where RQ is a resistor from this ball to ground. This ball can be connected directly to V_{DDQ} , which enables the minimum impedance mode. This ball cannot be connected directly to V_{SS} or left unconnected. The ODT termination values tracks the value of RQ. The ODT range is selected by ODT control input.	
ODT	Input	ODT control: When low; Low range mode is selected. The impedance range is between 52 Ω and 105 Ω (Thevenin equivalent), which follows $0.3 \times RQ$ for $175 \Omega \leq RQ \leq 350 \Omega$. ODT control:When high; High range mode is selected. The impedance range is between 105 Ω and 150 Ω (Thevenin equivalent), which follows $0.6 \times RQ$ for $175 \Omega \leq RQ \leq 250 \Omega$. ODT control:When floating; High range mode is selected.	

Name	I/O type	Descriptions	Note
DQ ₀ to DQ _n	Input Output	Synchronous data I/Os: Input data must meet setup and hold times around the rising edges of K and /K. Output data is synchronized to the K clock. The ×18 device uses DQ0 to DQ17. DQ18 to DQ35 should be treated as NC pin. The ×36 device uses DQ0 to DQ35.	
CQ, /CQ	Output	Synchronous echo clock outputs: The edges of these outputs are tightly matched to the synchronous data outputs and can be used as a data valid indication. These signals run freely and do not stop when DQ tri-states.	
TDO	Output	IEEE 1149.1 test output: 1.8 V I/O level.	
QVLD	Output	Valid output indicator: The Q Valid indicates valid output data. QVLD is edge aligned with CQ and /CQ.	
V _{DD}	Supply	Power supply: 1.8 V nominal. See DC Characteristics and Operating Conditions for range.	1
V _{DDQ}	Supply	Power supply: Isolated output buffer supply. Nominally 1.5 V. See DC Characteristics and Operating Conditions for range.	1
V _{SS}	Supply	Power supply: Ground.	1
V _{REF}	-	HSTL input reference voltage: Nominally V _{DDQ} /2, but may be adjusted to improve system noise margin. Provides a reference voltage for the HSTL input buffers.	
NC	-	No connect: These pins can be left floating or connected to 0V to V _{DDQ} .	

Notes:

1. All power supply and ground balls must be connected for proper operation of the device.

Block Diagram

[R1QEA4436RBG]

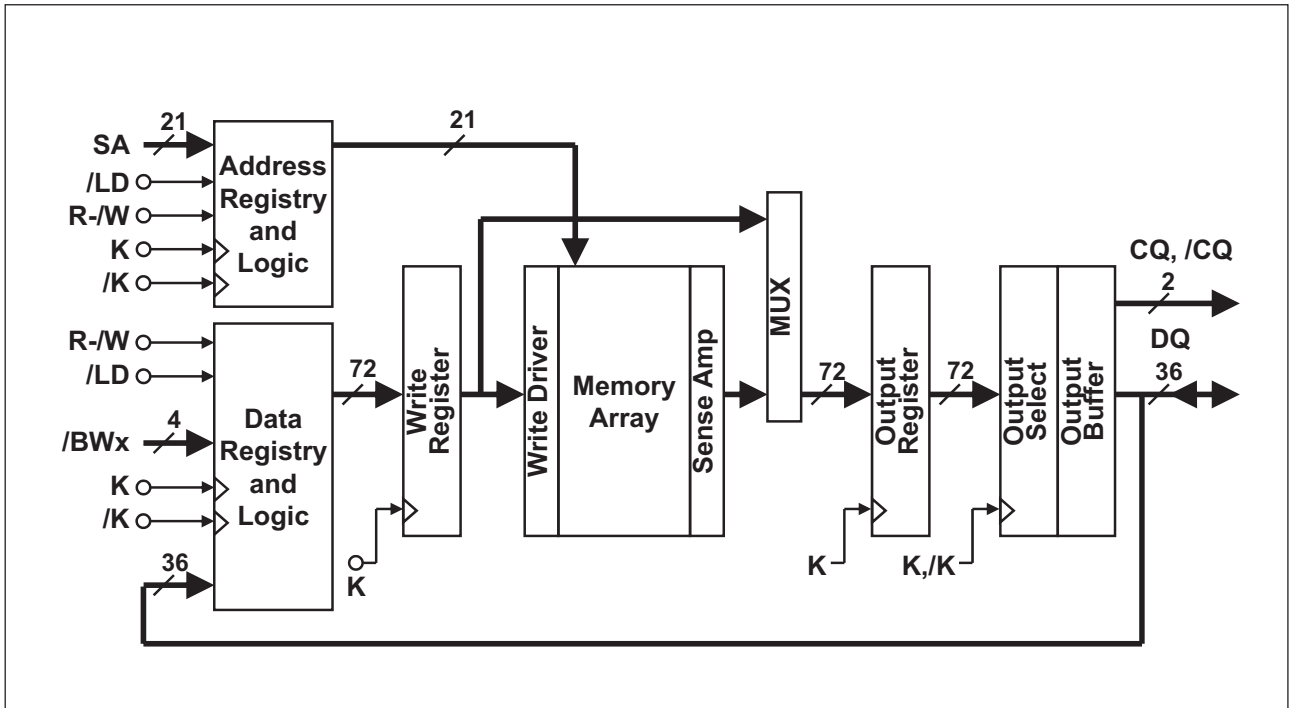

[R1QEA4418RBG]

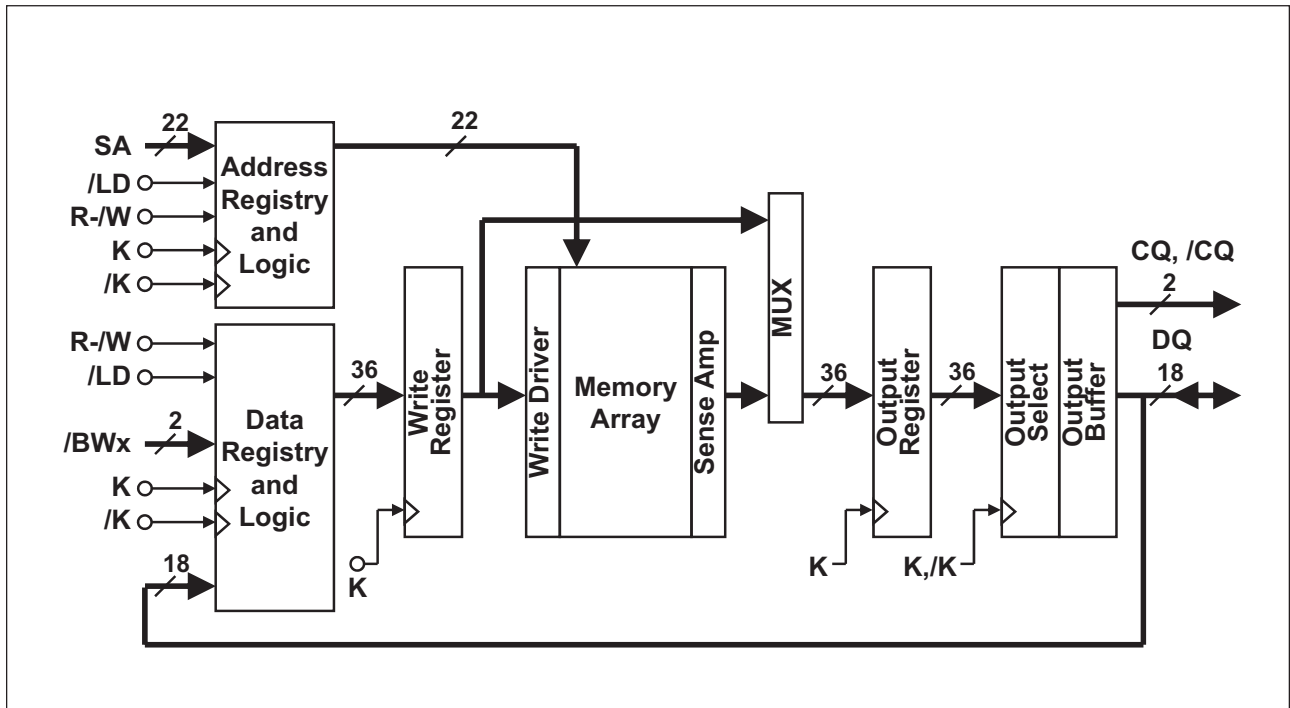

Power-up and Initialization Sequence

V_{DD} must be stable before K , $/K$ clocks are applied.

- Recommended voltage application sequence : $V_{SS} \rightarrow V_{DD} \rightarrow V_{DDQ} \& V_{REF} \rightarrow V_{IN}$. (0 V to V_{DD} , $V_{DDQ} < 200$ ms)
- Apply V_{REF} after V_{DDQ} or at the same time as V_{DDQ} .
- Then execute either one of the following sequences.

1. Single Clock Mode

- Drive $/DOFF$ high ($/DOFF$ can be tied high from the start).
- Then provide stable clocks (K , $/K$) for at least 20 us.

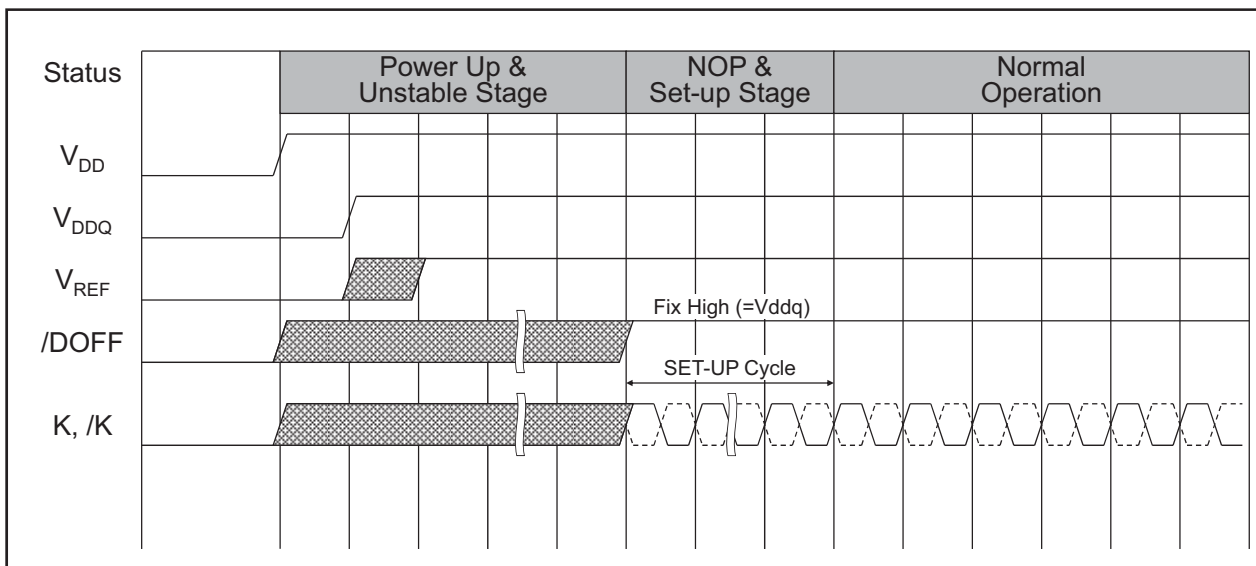

2. PLL Off Mode ($/DOFF$ tied low)

- In the "NOP and setup stage", provide stable clocks (K , $/K$) for at least 20 us.

PLL Constraints

1. These chips use the PLL. The clock input should have low phase jitter which is specified as t_{KC} var.
2. The lower end of the frequency at which the PLL can operate is 250 MHz.
(Please refer to AC Characteristics table for detail.)
3. When the operating frequency is changed or $/DOFF$ level is changed, setup cycles are required again.

Programmable Output Impedance

- Output buffer impedance can be programmed by terminating the ZQ ball to V_{SS} through a precision resistor (RQ). The value of RQ is five times the output impedance desired. The allowable range of RQ to guarantee impedance matching with a tolerance of 15% is between 175 Ω and 350 Ω . The total external capacitance of ZQ ball must be less than 7.5 pF.

QVLD (Valid data indicator)

- QVLD is provided on the QDR-II+ and DDR-II+ to simplify data capture on high speed systems. The Q Valid indicates valid output data. QVLD is activated half cycle before the read data for the receiver to be ready for capturing the data. QVLD is inactivated half cycle before the read finish for the receiver to stop capturing the data. QVLD is edge aligned with CQ and /CQ.

ODT (On Die Termination)

- To reduce reflection which produces noise and lowers signal quality, the signals should be terminated, especially at high frequency. Renesas offers ODT on the input signals to QDR-II+ and DDR-II+ family of devices.
- The ODT termination values tracks the value of RQ. The ODT range is selected by ODT control input.
- In DDR-II+ devices having common I/O bus, ODT is automatically enabled when the device inputs data and disabled when the device outputs data.
- There is no difference in AC timing characteristics between the SRAMs with ODT and SRAMs without ODT.
- There is no increase in the I_{DD} of SRAMs with ODT, however, there is an increase in the I_{DDQ} (current consumption from the I/O voltage supply) with ODT.

ODT range

ODT control pin	Thevenin equivalent resistance (R_{THEV})	Unit	Notes
Low	0.3 x RQ	Ω	1,3
High	0.6 x RQ	Ω	2
Floating	0.6 x RQ	Ω	2

Notes:

- Allowable range of RQ to guarantee impedance matching a tolerance of $\pm 20\%$ is $175\ \Omega \leq RQ \leq 350\ \Omega$.
- Allowable range of RQ to guarantee impedance matching a tolerance of $\pm 20\%$ is $175\ \Omega \leq RQ \leq 250\ \Omega$.
- ODT control pin is connected to V_{DDQ} through 3.5 k Ω . Therefore it is recommended to connect it to V_{SS} through less than 100 Ω to make it low.

Thevenin termination

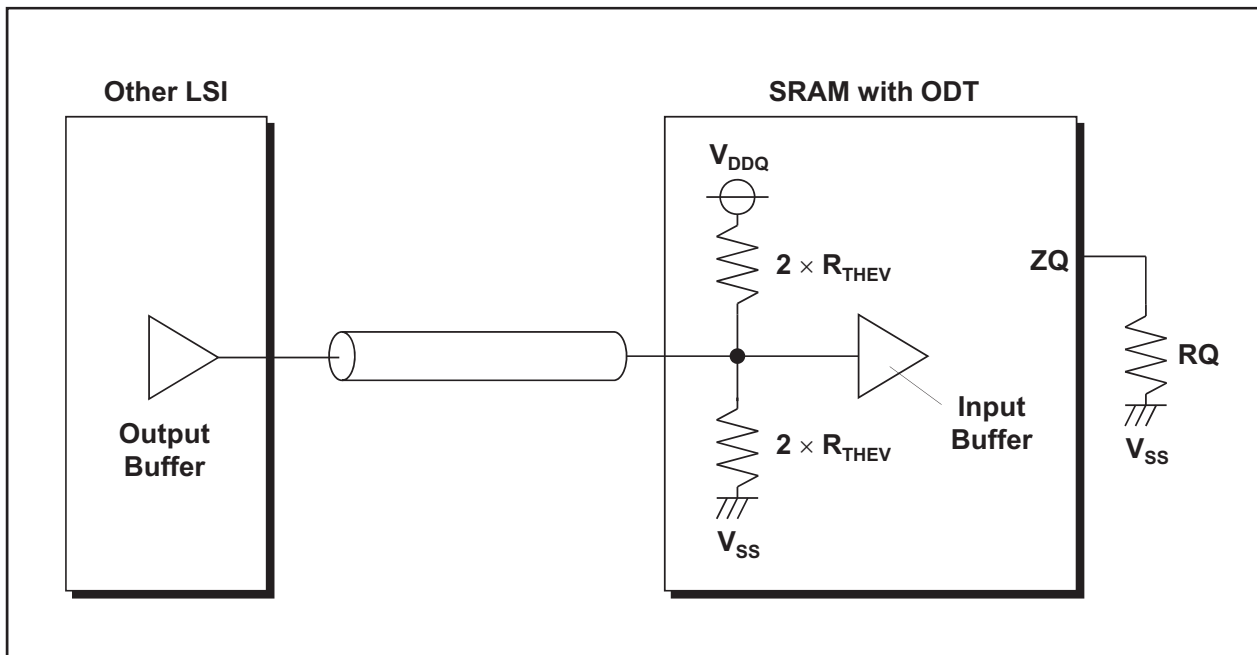

ODT pin

Pin name	ODT On/Off
DQ ₀ to DQ _n	Off: First Read Command + Read Latency - 0.5 cycle On: Last Read Command + Read Latency + BL/2 cycle + 0.5 cycle (See below timing chart)
/BW _x	Always On
K, /K	Always On

K Truth Table

Operation	K	/LD	R-/W	DQ		
Write Cycle: Load address, input write data on two consecutive K and /K rising edges	↑	L	L	Data in		
				Input data	D(A+0)	D(A+1)
				Input clock	K(t+1) ↑	/K(t+1) ↑
Read Cycle: Load address, output read data on two consecutive K and /K rising edges	↑	L	H	Data out		
				Output data	Q(A+0)	Q(A+1)
				Input clock	/K(t+2) ↑	K(t+3) ↑
NOP (No operation)	↑	H	×	High-Z		
Standby (Clock stopped)	Stopped	×	×	Previous state		

Notes:

1. H: high level, L: low level, ×: don't care, ↑: rising edge.
2. Data inputs are registered at K and /K rising edges. Data outputs are delivered at K clock edges.
3. /LD and R-/W must meet setup/hold times around the rising edges (low to high) of K and are registered at the rising edge of K.
4. This device contains circuitry that will ensure the outputs will be in high-Z during power-up.
5. Refer to state diagram and timing diagrams for clarification.
6. When clocks are stopped, the following cases are recommended; the case of K = low, /K = high, or the case of K = high, /K = low. This condition is not essential, but permits most rapid restart by overcoming transmission line charging symmetrically.
7. A+0 refers to the address input during a WRITE or READ cycle. A+1 refers to the next internal burst address in accordance with the linear burst sequence.

Byte Write Truth Table (x 36)

Operation	K	/K	/BW0	/BW1	/BW2	/BW3
Write D0 to D35	↑	-	L	L	L	L
	-	↑	L	L	L	L
Write D0 to D8	↑	-	L	H	H	H
	-	↑	L	H	H	H
Write D9 to D17	↑	-	H	L	H	H
	-	↑	H	L	H	H
Write D18 to D26	↑	-	H	H	L	H
	-	↑	H	H	L	H
Write D27 to D35	↑	-	H	H	H	L
	-	↑	H	H	H	L
Write nothing	↑	-	H	H	H	H
	-	↑	H	H	H	H

Notes:

1. H: high level, L: low level, ↑: rising edge.
2. Assumes a WRITE cycle was initiated. /BWx can be altered for any portion of the BURST WRITE operation provided that the setup and hold requirements are satisfied.

Byte Write Truth Table (x 18)

Operation	K	/K	/BW0	/BW1
Write D0 to D17	↑	-	L	L
	-	↑	L	L
Write D0 to D8	↑	-	L	H
	-	↑	L	H
Write D9 to D17	↑	-	H	L
	-	↑	H	L
Write nothing	↑	-	H	H
	-	↑	H	H

Notes:

1. H: high level, L: low level, ↑: rising edge.
2. Assumes a WRITE cycle was initiated. /BWx can be altered for any portion of the BURST WRITE operation provided that the setup and hold requirements are satisfied.

Bus Cycle State Diagram

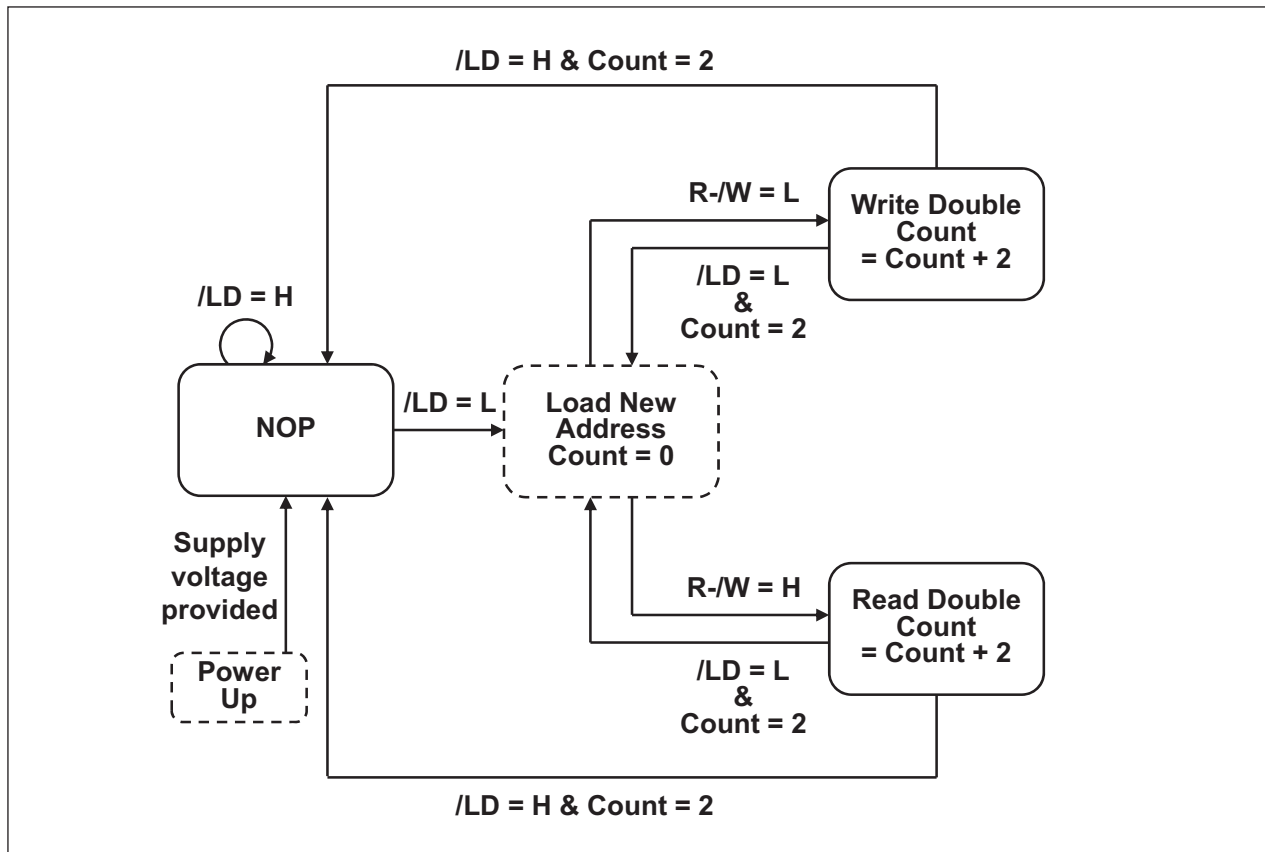

Notes:

1. Bus cycle is terminated at the end of this sequence (burst count = 2).
2. State machine control timing sequence is controlled by K.

Electrical Characteristics

Absolute Maximum Ratings

Parameter	Symbol	Rating	Unit	Notes
Input voltage on any ball	V_{IN}	-0.5 to $V_{DD} + 0.5$ (2.5 V max.)	V	1,4
Input/output voltage	$V_{I/O}$	-0.5 to $V_{DDQ} + 0.5$ (2.5 V max.)	V	1,4
Core supply voltage	V_{DD}	-0.5 to 2.5	V	1,4
Output supply voltage	V_{DDQ}	-0.5 to V_{DD}	V	1,4
Junction temperature	T_j	+125 (max)	°C	5
Storage temperature	T_{STG}	-55 to +125	°C	

Notes:

- All voltage is referenced to V_{SS} .
- Permanent device damage may occur if Absolute Maximum Ratings are exceeded. Functional operation should be restricted the Operation Conditions. Exposure to higher than recommended voltages for extended periods of time could affect device reliability.
- These CMOS memory circuits have been designed to meet the DC and AC specifications shown in the tables after thermal equilibrium has been established.
- The following supply voltage application sequence is recommended: V_{SS} , V_{DD} , V_{DDQ} , V_{REF} then V_{IN} . Remember, according to the Absolute Maximum Ratings table, V_{DDQ} is not to exceed 2.5 V, whatever the instantaneous value of V_{DDQ} .
- Some method of cooling or airflow should be considered in the system.

Recommended DC Operating Conditions

Parameter	Symbol	Min	Typ	Max	Unit	Notes
Power supply voltage -- core	V_{DD}	1.7	1.8	1.9	V	1
Power supply voltage -- I/O	V_{DDQ}	1.4	1.5	V_{DD}	V	1,2
Input reference voltage -- I/O	V_{REF}	0.68	0.75	0.95	V	3
Input high voltage	$V_{IH(DC)}$	$V_{REF} + 0.1$	-	$V_{DDQ} + 0.3$	V	1,4,5
Input low voltage	$V_{IL(DC)}$	-0.3	-	$V_{REF} - 0.1$	V	1,4,5

Notes:

- At power-up, V_{DD} and V_{DDQ} are assumed to be a linear ramp from 0V to $V_{DD}(\text{min.})$ or $V_{DDQ}(\text{min.})$ within 200ms. During this time, $V_{DDQ} < V_{DD}$ and $V_{IH} < V_{DDQ}$. During normal operation, V_{DDQ} must not exceed V_{DD} .
- Please pay attention to T_j not to exceed the temperature shown in the absolute maximum ratings table due to current from V_{DDQ} .
- Peak to peak AC component superimposed on V_{REF} may not exceed 5% of V_{REF} .
- These are DC test criteria. The AC V_{IH} / V_{IL} levels are defined separately to measure timing parameters.
- Overshoot: $V_{IH(AC)} \leq V_{DDQ} + 0.5 \text{ V}$ for $t \leq t_{KHKH}/2$
Undershoot: $V_{IL(AC)} \geq -0.5 \text{ V}$ for $t \leq t_{KHKH}/2$
During normal operation, $V_{IH(DC)}$ must not exceed V_{DDQ} and $V_{IL(DC)}$ must not be lower than V_{SS} .

DC Characteristics

($T_A = -40$ to $+85^\circ\text{C}$, $V_{DD} = 1.8\text{V} \pm 0.1\text{V}$, $V_{DDQ} = 1.5\text{V}$, $V_{REF} = 0.75\text{V}$)

Parameter	Symbol	Test condition	MIN.	MAX.			Unit	Notes
				-18	-19	-20		
Operating Supply Current (Write / Read)	I_{DD}		(x36)	1340	1300	1250	mA	1,2,3
			(x18)	1100	1070	1020		
Standby Supply Current (NOP)	I_{SB1}		(x36)	1050	1020	980	mA	2,4,5
			(x18)	900	880	840		
Input leakage current	I_{LI}		-2	2			μA	9
Output leakage current	I_{LO}		-5	5			μA	10
Output high voltage	V_{OH} (Low)	$ I_{OH} \leq 0.1 \text{ mA}$	$V_{DDQ} - 0.2$	V_{DDQ}			V	8
	V_{OH}	Note 6	$V_{DDQ}/2 - 0.12$	$V_{DDQ}/2 + 0.12$			V	8
Output low voltage	V_{OL} (Low)	$I_{OL} \leq 0.1 \text{ mA}$	V_{SS}	0.2			V	8
	V_{OL}	Note 7	$V_{DDQ}/2 - 0.12$	$V_{DDQ}/2 + 0.12$			V	8

Notes:

- All inputs (except ZQ, V_{REF}) are held at either V_{IH} or V_{IL} .
- $I_{OUT} = 0 \text{ mA}$. $V_{DD} = V_{DD} \text{ max}$, $t_{KHKH} = t_{KHKH} \text{ min}$.
- Operating supply currents (I_{DD}) are measured at 100% bus utilization. I_{DD} of DDR family is current of device with 100% write cycle (if $I_{DD}(\text{Write}) > I_{DD}(\text{Read})$) or 100% read cycle (if $I_{DD}(\text{Write}) < I_{DD}(\text{Read})$).
- All address / data inputs are static at either $V_{IN} > V_{IH}$ or $V_{IN} < V_{IL}$.
- Reference value. (Condition = NOP currents are valid when entering NOP after all pending READ and WRITE cycles are completed.)
- Outputs are impedance-controlled. $|I_{OH}| = (V_{DDQ}/2)/(RQ/5)$ for values of $175 \Omega \leq RQ \leq 350 \Omega$.
- Outputs are impedance-controlled. $I_{OL} = (V_{DDQ}/2)/(RQ/5)$ for values of $175 \Omega \leq RQ \leq 350 \Omega$.
- AC load current is higher than the shown DC values. AC I/O curves are available upon request.
- $0 \leq V_{IN} \leq V_{DDQ}$ for all input balls (except V_{REF} , DQn, /BWx, K, /K, ZQ, ODT, TCK, TMS, TDI ball).
- $0 \leq V_{OUT} \leq V_{DDQ}$ (except TDO ball), output disabled.

Thermal Resistance

Parameter	Symbol	Airflow	Typ	Unit	Test condition	Notes
Junction to Ambient	θ_{JA}	1 m/s	9.7	°C/W	EIA/JEDEC JESD51	1
Junction to Case	θ_{JC}	-	4.4			

Notes:

- These parameters are calculated under the condition. These are reference values.
- $T_j = T_a + \theta_{JA} \times P_d$
 $T_j = T_c + \theta_{JC} \times P_d$
 where
 T_j : junction temperature when the device has achieved a steady-state after application of P_d (°C)
 T_a : ambient temperature (°C)
 T_c : temperature of external surface of the package or case (°C)
 θ_{JA} : thermal resistance from junction-to-ambient (°C/W)
 θ_{JC} : thermal resistance from junction-to-case (package) (°C/W)
 P_d : power dissipation that produced change in junction temperature (W) (cf.JESD51-2A)

Capacitance

($T_A = +25^\circ\text{C}$, Frequency = 1.0MHz, $V_{DD} = 1.8\text{V}$, $V_{DDQ} = 1.5\text{V}$)

Parameter	Symbol	Min	Typ	Max	Unit	Test condition	Note
Input capacitance (SA, /R, /W, /BW)	C_{IN}	-	4	5	pF	$V_{IN} = 0\text{V}$	1,2
Clock input capacitance (K, /K)	C_{CLK}	-	4	5	pF	$V_{CLK} = 0\text{V}$	1,2
Output capacitance (DQ, CQ, /CQ)	C_{IO}	-	5	6	pF	$V_{IO} = 0\text{V}$	1,2

Notes:

- These parameters are sampled and not 100% tested.
- Except JTAG (TCK, TMS, TDI, TDO) pins.

AC Test Conditions

Input waveform (Rise/fall time $\leq 0.3\text{ ns}$)

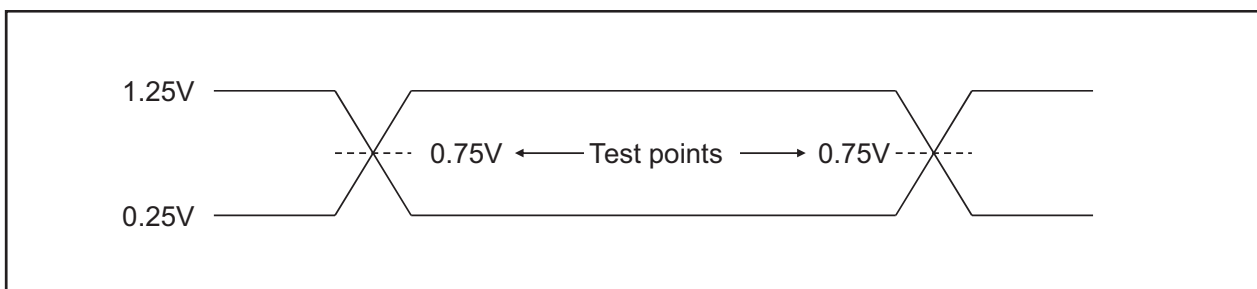

Output waveform

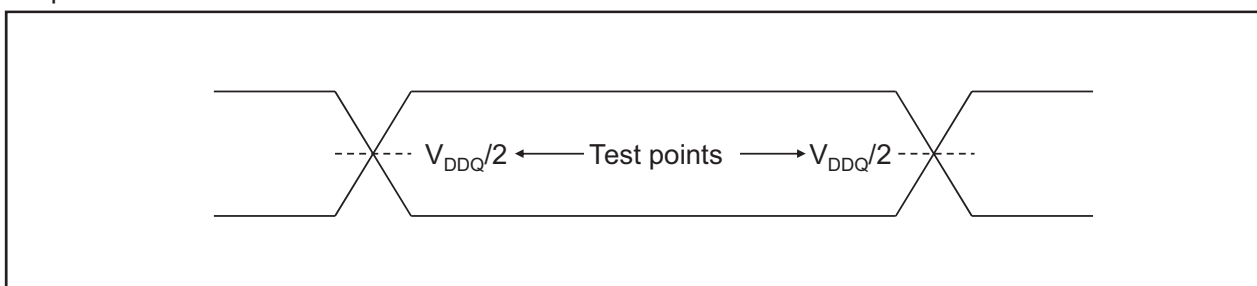

Output load conditions

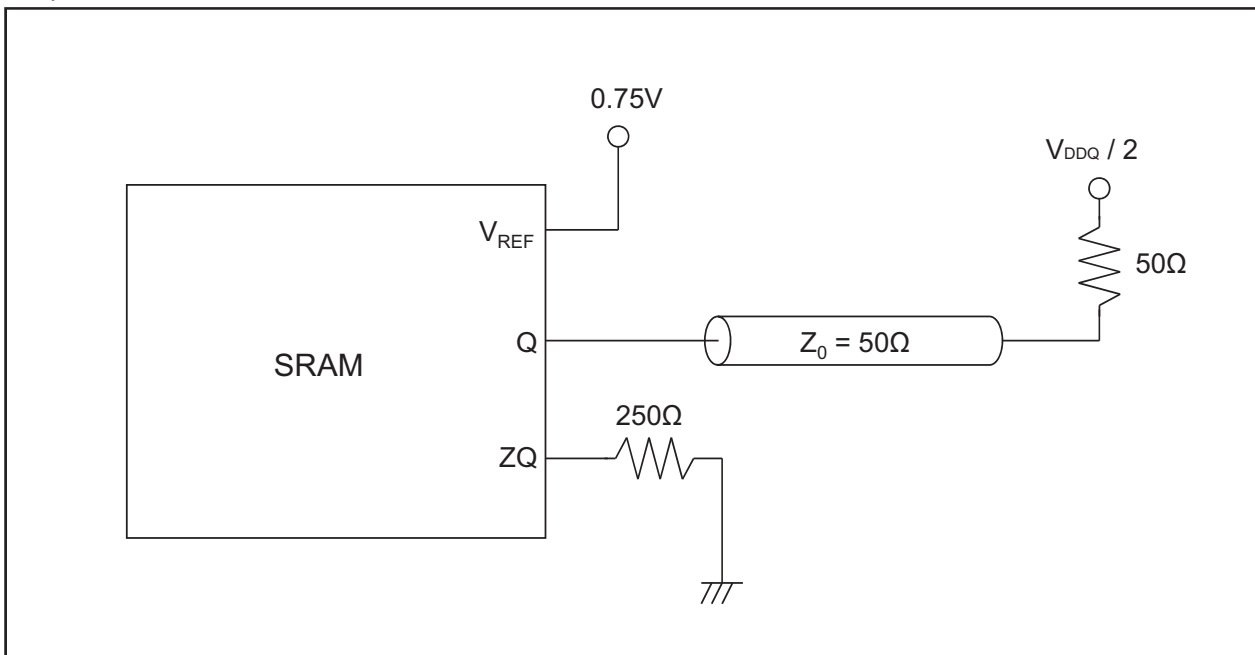

AC Operating Conditions

Parameter	Symbol	Min	Typ	Max	Unit	Notes
Input high voltage	$V_{IH(AC)}$	$V_{REF} + 0.2$	-	-	V	1,2,3,4
Input low voltage	$V_{IL(AC)}$	-	-	$V_{REF} - 0.2$	V	1,2,3,4

Notes:

- All voltages referenced to V_{SS} (GND). During normal operation, V_{DDQ} must not exceed V_{DD} .
- These conditions are for AC functions only, not for AC parameter test.
- Overshoot: $V_{IH(AC)} \leq V_{DDQ} + 0.5$ V for $t \leq t_{KHKH}/2$
 Undershoot: $V_{IL(AC)} \geq -0.5$ V for $t \leq t_{KHKH}/2$
 Control input signals may not have pulse widths less than t_{KHKL} (min) or operate at cycle rates less than t_{KHKH} (min).
- To maintain a valid level, the transitioning edge of the input must:
 - Sustain a constant slew rate from the current AC level through the target AC level, $V_{IL(AC)}$ or $V_{IH(AC)}$.
 - Reach at least the target AC level.
 - After the AC target level is reached, continue to maintain at least the target DC level, $V_{IL(DC)}$ or $V_{IH(DC)}$.

AC Characteristics

($T_A = -40$ to $+85^\circ\text{C}$, $V_{DD} = 1.8\text{V} \pm 0.1\text{V}$, $V_{DDQ} = 1.5\text{V}$, $V_{REF} = 0.75\text{V}$)

Parameter	Symbol	-18		-19		-20		Unit	Notes
		Min	Max	Min	Max	Min	Max		
Clock									
Average clock cycle time (K, /K)	t_{KHKH}	1.810	4.00	1.875	4.00	2.00	4.00	ns	
Clock high time (K, /K)	t_{KHKL}	0.40	-	0.40	-	0.40	-	Cycle	
Clock low time (K, /K)	t_{LKHL}	0.40	-	0.40	-	0.40	-	Cycle	
Clock to /clock (K to /K)	$t_{KH/KH}$	0.425	-	0.425	-	0.425	-	Cycle	
/Clock to clock (/K to K)	$t_{/KHKH}$	0.425	-	0.425	-	0.425	-	Cycle	
PLL Timing									
Clock phase jitter (K, /K)	$t_{KC \text{ var}}$	-	0.15	-	0.15	-	0.15	ns	3
Lock time (K)	$t_{KC \text{ lock}}$	20	-	20	-	20	-	us	2
K static to PLL reset	$t_{KC \text{ reset}}$	30	-	30	-	30	-	ns	5
Output Times									
K, /K high to output valid	t_{CHQV}	-	0.45	-	0.45	-	0.45	ns	
K, /K high to output hold	t_{CHQX}	-0.45	-	-0.45	-	-0.45	-	ns	
K, /K high to echo clock valid	t_{CHCQV}	-	0.45	-	0.45	-	0.45	ns	
K, /K high to echo clock hold	t_{CHCQX}	-0.45	-	-0.45	-	-0.45	-	ns	
CQ, /CQ high to output valid	t_{CQHQV}	-	0.15	-	0.15	-	0.15	ns	5
CQ, /CQ high to output hold	t_{CQHQX}	-0.15	-	-0.15	-	-0.15	-	ns	5
K, /K high to output high-Z	t_{CHQZ}	-	0.45	-	0.45	-	0.45	ns	4
K, /K high to output low-Z	t_{CHQX1}	-0.45	-	-0.45	-	-0.45	-	ns	4
CQ high to QVLD valid	t_{QVLD}	-0.15	0.15	-0.15	0.15	-0.15	0.15	ns	5
Setup Times									
Address valid to K rising edge	t_{AVKH}	0.30	-	0.30	-	0.33	-	ns	1,6
Control inputs valid to K rising edge	t_{IVKH}	0.30	-	0.30	-	0.33	-	ns	1,6
Data-in valid to K, /K rising edge	t_{DVKH}	0.20	-	0.20	-	0.22	-	ns	1,7
Hold Times									
K rising edge to address hold	t_{KHAX}	0.30	-	0.30	-	0.33	-	ns	1,6
K rising edge to control inputs hold	t_{KHIX}	0.30	-	0.30	-	0.33	-	ns	1,6
K, /K rising edge to data-in hold	t_{KHDX}	0.20	-	0.20	-	0.22	-	ns	1,7

Notes:

1. This is a synchronous device. All addresses, data and control lines must meet the specified setup and hold times for all latching clock edges.
2. V_{DD} and V_{DDQ} slew rate must be less than 0.1 V DC per 50 ns for PLL lock retention. PLL lock time begins once V_{DD} , V_{DDQ} and input clock are stable.
It is recommended that the device is kept inactive during these cycles.
3. Clock phase jitter is the variance from clock rising edge to the next expected clock rising edge.
4. Transitions are measured ± 100 mV from steady-state voltage.
5. These parameters are sampled.
6. t_{AVKH} , t_{VVKH} , t_{KHAX} , t_{KHIX} spec is determined by the actual frequency regardless of Part Number (Marking Name).
The following is the spec for the actual frequency.
0.30 ns for $\leq 550\text{MHz}$ & $> 500\text{MHz}$
0.33 ns for $\leq 500\text{MHz}$ & $> 450\text{MHz}$
0.40 ns for $\leq 450\text{MHz}$ & $\geq 250\text{MHz}$
7. t_{DVKH} , t_{KHDX} spec is determined by the actual frequency regardless of Part Number (Marking Name). The following is the spec for the actual frequency.
0.20 ns for $\leq 550\text{MHz}$ & $> 500\text{MHz}$
0.22 ns for $\leq 500\text{MHz}$ & $> 450\text{MHz}$
0.25 ns for $\leq 450\text{MHz}$ & $> 400\text{MHz}$
0.28 ns for $\leq 400\text{MHz}$ & $\geq 250\text{MHz}$

Remarks:

1. Test conditions as specified with the output loading as shown in AC Test Conditions unless otherwise noted.
2. Control input signals may not be operated with pulse widths less than t_{KHKL} (min).
3. V_{DDQ} is +1.5 V DC. V_{REF} is +0.75 V DC.
4. Control signals are /LD and R-/W.
Setup and hold times of /BWx signals must be the same as those of Data-in signals.

Read and Write Timing

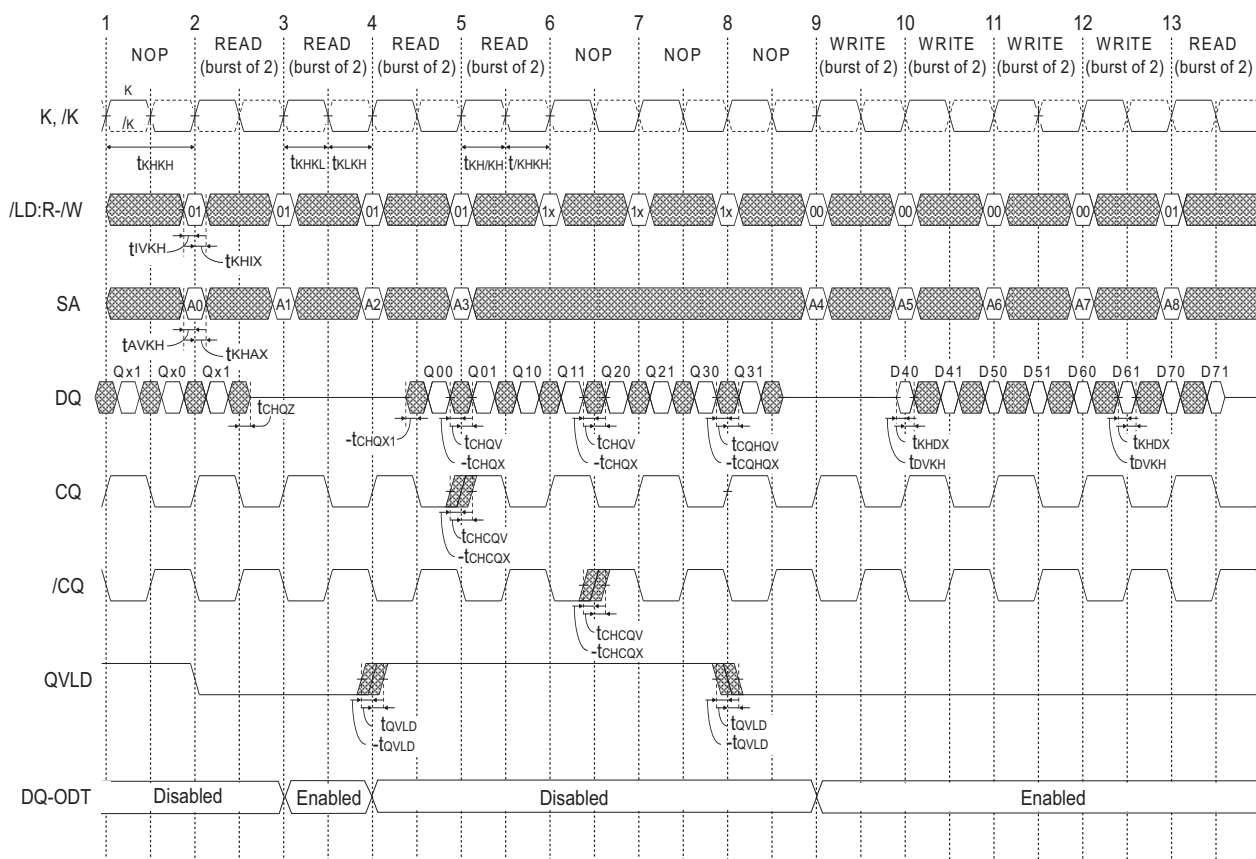

Notes:

1. Q00 refers to output from address A0. Q01 refers to output from the next internal burst address following A0, i.e., A0+1.
2. In this example, if address A8 = A7, then data Q80 = D70, Q81 = D71, etc. Write data is forwarded immediately as read results.
3. To control read and write operations, /BW signals must operate at the same timing as Data-in signals.
4. It recommends three NOP cycles during transition from READ to WRITE cycle for correct device operation.

JTAG Specification

These products support a limited set of JTAG functions as in IEEE standard 1149.1.

Disabling the Test Access Port

It is possible to use this device without utilizing the TAP. To disable the TAP controller without interfering with normal operation of the device, TCK must be tied to V_{SS} to preclude mid level inputs.

TDI and TMS are internally pulled up and may be unconnected, or may be connected to V_{DD} through a pull up resistor. TDO should be left unconnected.

Test Access Port (TAP) Pins

Symbol I/O	Pin assignments	Description	Notes
TCK	2R	Test clock input. All inputs are captured on the rising edge of TCK and all outputs propagate from the falling edge of TCK.	
TMS	10R	Test mode select. This is the command input for the TAP controller state machine.	
TDI	11R	Test data input. This is the input side of the serial registers placed between TDI and TDO. The register placed between TDI and TDO is determined by the state of the TAP controller state machine and the instruction that is currently loaded in the TAP instruction.	
TDO	1R	Test data output. Output changes in response to the falling edge of TCK. This is the output side of the serial registers placed between TDI and TDO.	

Notes:

The device does not have TRST (TAP reset). The Test-Logic Reset state is entered while TMS is held high for five rising edges of TCK. The TAP controller state is also reset on SRAM POWER-UP.

TAP DC Operating Characteristics

($T_A = -40$ to $+85^\circ\text{C}$, $V_{DD} = 1.8\text{V} \pm 0.1\text{V}$)

Parameter	Symbol	Min	Typ	Max	Unit	Notes
Input high voltage	V_{IH}	+1.3	-	$V_{DD} + 0.3$	V	
Input low voltage	V_{IL}	-0.3	-	+0.5	V	
Input leakage current	I_{LI}	-5.0	-	+5.0	μA	$0\text{V} \leq V_{IN} \leq V_{DD}$
Output leakage current	I_{LO}	-5.0	-	+5.0	μA	$0\text{V} \leq V_{IN} \leq V_{DD}$, output disabled
Output low voltage	V_{OL1}	-	-	0.2	V	$I_{OLC} = 100\ \mu\text{A}$
	V_{OL2}	-	-	0.4	V	$I_{OLT} = 2\ \text{mA}$
Output high voltage	V_{OH1}	1.6	-	-	V	$ I_{OHC} = 100\ \mu\text{A}$
	V_{OH2}	1.4	-	-	V	$ I_{OHT} = 2\ \text{mA}$

Notes:

- All voltages referenced to V_{SS} (GND).
- At power-up, V_{DD} and V_{DDQ} are assumed to be a linear ramp from 0V to $V_{DD}(\text{min.})$ or $V_{DDQ}(\text{min.})$ within 200ms. During this time, $V_{DDQ} < V_{DD}$ and $V_{IH} < V_{DDQ}$.

During normal operation, V_{DDQ} must not exceed V_{DD} .

TAP AC Test Conditions

Parameter	Symbol	Conditions	Unit	Notes
Input timing measurement reference levels	V_{REF}	0.9	V	
Input pulse levels	V_{IL}, V_{IH}	0 to 1.8	V	
Input rise/fall time	t_r, t_f	≤ 1.0	ns	
Output timing measurement reference levels		0.9	V	
Test load termination supply voltage (V_{TT})		0.9	V	
Output load		See figures		

Input waveform

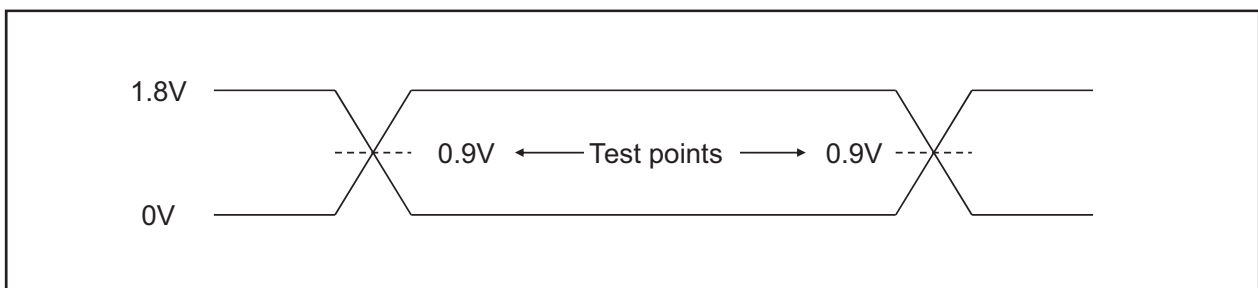

Output waveform

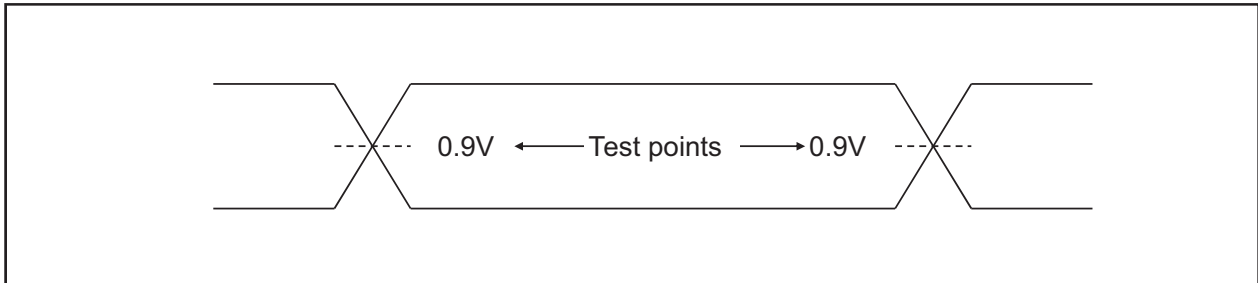

Output load condition

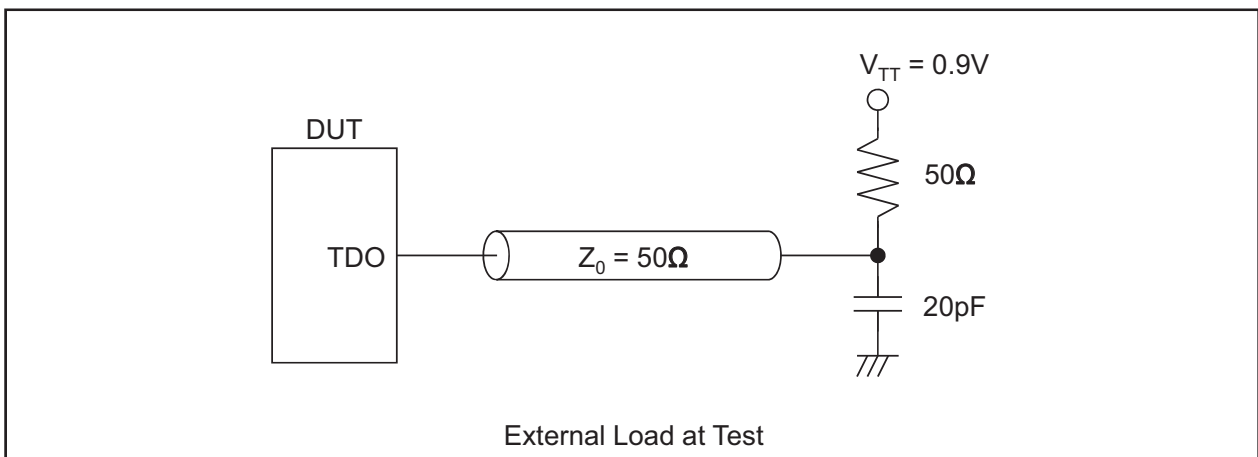

TAP AC Operating Characteristics(T_A = -40 to +85°C, V_{DD} = 1.8V ±0.1V)

Parameter	Symbol	Min	Typ	Max	Unit	Notes
Test clock (TCK) cycle time	t _{THTH}	50	-	-	ns	
TCK high pulse width	t _{THTL}	20	-	-	ns	
TCK low pulse width	t _{TLTH}	20	-	-	ns	
Test mode select (TMS) setup	t _{MVTH}	5	-	-	ns	
TMS hold	t _{THMX}	5	-	-	ns	
Capture setup	t _{CS}	5	-	-	ns	
Capture hold	t _{CH}	5	-	-	ns	
TDI valid to TCK high	t _{DVTH}	5	-	-	ns	
TCK high to TDI invalid	t _{THDX}	5	-	-	ns	
TCK low to TDO unknown	t _{TLQX}	0	-	-	ns	
TCK low to TDO valid	t _{TLQV}	-	-	10	ns	

Notes:

1. t_{CS} + t_{CH} defines the minimum pause in RAM I/O pad transitions to assure pad data capture.

TAP Controller Timing Diagram

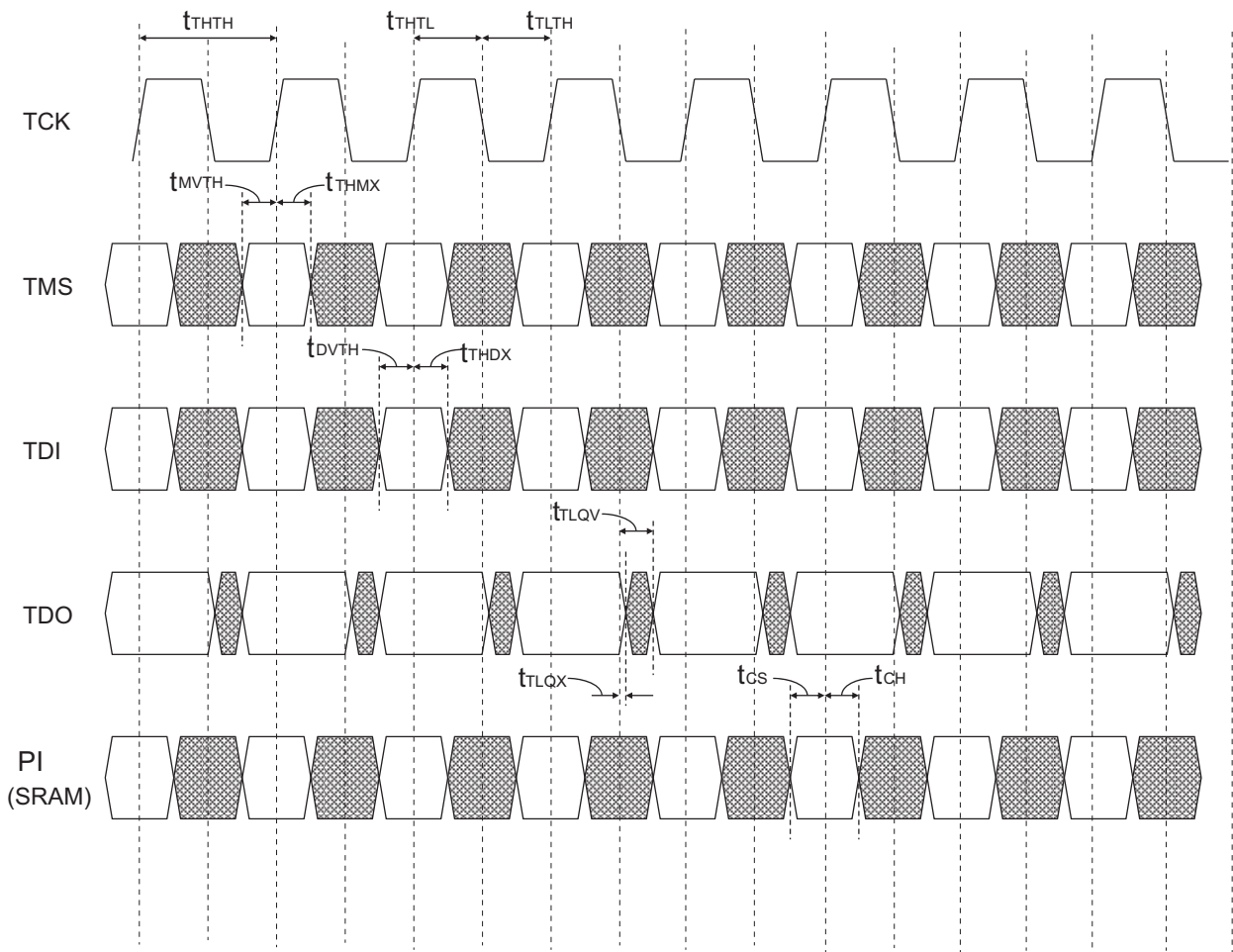

Test Access Port Registers

Register name	Length	Symbol	Notes
Instruction register	3 bits	IR [2:0]	
Bypass register	1 bits	BP	
ID register	32 bits	ID [31:0]	
Boundary scan register	109 bit	BS [109:1]	

TAP Controller Instruction Set

IR2	IR1	IR0	Instruction	Description	Notes
0	0	0	EXTEST	The EXTEST instruction allows circuitry external to the component package to be tested. Boundary scan register cells at output balls are used to apply test vectors, while those at input balls capture test results. Typically, the first test vector to be applied using the EXTEST instruction will be shifted into the boundary scan register using the PRELOAD instruction. Thus, during the Update-IR state of EXTEST, the output driver is turned on and the PRELOAD data is driven onto the output balls.	1,2,3,4
0	0	1	IDCODE	The IDCODE instruction causes the ID ROM to be loaded into the ID register when the controller is in capture-DR mode and places the ID register between the TDI and TDO balls in shift-DR mode. The IDCODE instruction is the default instruction loaded in at power up and any time the controller is placed in the Test-Logic-Reset state.	
0	1	0	SAMPLE-Z	If the SAMPLE-Z instruction is loaded in the instruction register, all RAM outputs are forced to an inactive drive state (high-Z), moving the TAP controller into the capture-DR state loads the data in the RAMs input into the boundary scan register, and the boundary scan register is connected between TDI and TDO when the TAP controller is moved to the shift-DR state.	3,4
0	1	1	RESERVED	The RESERVED instruction is not implemented but is reserved for future use. Do not use this instruction.	
1	0	0	SAMPLE (PRELOAD)	When the SAMPLE instruction is loaded in the instruction register, moving the TAP controller into the capture-DR state loads the data in the RAMs input and I/O buffers into the boundary scan register. Because the RAM clock(s) are independent from the TAP clock (TCK) it is possible for the TAP to attempt to capture the I/O ring contents while the input buffers are in transition (i.e., in a metastable state). Although allowing the TAP to SAMPLE metastable input will not harm the device, repeatable results cannot be expected. Moving the controller to shift-DR state then places the boundary scan register between the TDI and TDO balls.	3,4
1	0	1	RESERVED	The RESERVED instruction is not implemented but is reserved for future use. Do not use this instruction.	
1	1	0	RESERVED	The RESERVED instruction is not implemented but is reserved for future use. Do not use this instruction.	
1	1	1	BYPASS	The BYPASS instruction is loaded in the instruction register when the bypass register is placed between TDI and TDO. This occurs when the TAP controller is moved to the shift-DR state. This allows the board level scan path to be shortened to facilitate testing of other devices in the scan path.	

Notes:

1. Data in output register is not guaranteed if EXTEST instruction is loaded.
2. After performing EXTEST, power-up conditions are required in order to return part to normal operation.
3. RAM input signals must be stabilized for long enough to meet the TAPs input data capture setup plus hold time (t_{CS} plus t_{CH}). The RAMs clock inputs need not be paused for any other TAP operation except capturing the I/O ring contents into the boundary scan register.
4. Clock recovery initialization cycles are required after boundary scan.

Boundary Scan Order

Bit#	Ball ID	Signal names	
		x18	x36
1	6R	ODT	ODT
2	6P	QVLD	QVLD
3	6N	SA	SA
4	7P	SA	SA
5	7N	SA	SA
6	7R	SA	SA
7	8R	SA	SA
8	8P	SA	SA
9	9R	SA	SA
10	11P	DQ0	DQ0
11	10P	NC	DQ9
12	10N	NC	NC
13	9P	NC	NC
14	10M	DQ1	DQ11
15	11N	NC	DQ10
16	9M	NC	NC
17	9N	NC	NC
18	11L	DQ2	DQ2
19	11M	NC	DQ1
20	9L	NC	NC
21	10L	NC	NC
22	11K	DQ3	DQ3
23	10K	NC	DQ12
24	9J	NC	NC
25	9K	NC	NC
26	10J	DQ4	DQ13
27	11J	NC	DQ4
28	11H	ZQ	ZQ
29	10G	NC	NC
30	9G	NC	NC
31	11F	DQ5	DQ5
32	11G	NC	DQ14
33	9F	NC	NC
34	10F	NC	NC
35	11E	DQ6	DQ6
36	10E	NC	DQ15
37	10D	NC	NC

Bit#	Ball ID	Signal names	
		x18	x36
38	9E	NC	NC
39	10C	DQ7	DQ17
40	11D	NC	DQ16
41	9C	NC	NC
42	9D	NC	NC
43	11B	DQ8	DQ8
44	11C	NC	DQ7
45	9B	NC	NC
46	10B	NC	NC
47	11A	CQ	CQ
48	10A	SA	SA
49	9A	SA	SA
50	8B	SA	SA
51	7C	SA	SA
52	6C	NC	NC
53	8A	/LD	/LD
54	7A	SA	/BW1
55	7B	/BW0	/BW0
56	6B	K	K
57	6A	/K	/K
58	5B	NC	/BW3
59	5A	/BW1	/BW2
60	4A	R-/W	R-/W
61	5C	SA	SA
62	4B	SA	SA
63	3A	SA	SA
64	2A	SA	SA
65	1A	/CQ	/CQ
66	2B	DQ9	DQ27
67	3B	NC	DQ18
68	1C	NC	NC
69	1B	NC	NC
70	3D	DQ10	DQ19
71	3C	NC	DQ28
72	1D	NC	NC
73	2C	NC	NC
74	3E	DQ11	DQ20

Bit#	Ball ID	Signal names	
		x18	x36
75	2D	NC	DQ29
76	2E	NC	NC
77	1E	NC	NC
78	2F	DQ12	DQ30
79	3F	NC	DQ21
80	1G	NC	NC
81	1F	NC	NC
82	3G	DQ13	DQ22
83	2G	NC	DQ31
84	1H	/DOFF	/DOFF
85	1J	NC	NC
86	2J	NC	NC
87	3K	DQ14	DQ23
88	3J	NC	DQ32
89	2K	NC	NC
90	1K	NC	NC
91	2L	DQ15	DQ33
92	3L	NC	DQ24
93	1M	NC	NC
94	1L	NC	NC
95	3N	DQ16	DQ25
96	3M	NC	DQ34
97	1N	NC	NC
98	2M	NC	NC
99	3P	DQ17	DQ26
100	2N	NC	DQ35
101	2P	NC	NC
102	1P	NC	NC
103	3R	SA	SA
104	4R	SA	SA
105	4P	SA	SA
106	5P	SA	SA
107	5N	SA	SA
108	5R	SA	SA
109	-	Internal	Internal

Notes:

In boundary scan mode,

1. Clock balls (K, /K) are referenced to each other and must be at opposite logic levels for reliable operation.
2. CQ and /CQ data are synchronized to the K clock (except EXTEST, SAMPLE-Z).

ID Register

	Revision number (31:29)			Type number (28:12)													Vendor JEDEC code (11:1)							Start bit(0) → ↓											
#	31	30	29	28	27	26	25	24	23	22	21	20	19	18	17	16	15	14	13	12	11	10	9	8	7	6	5	4	3	2	1	0			
Symbol	R	R	R	O	C	M	M	M	A	W	W	O	I	Q	Q	Q	B	O	S	O	O	O	I	O	O	O	I	O	O	O	I	I	I	I	Q

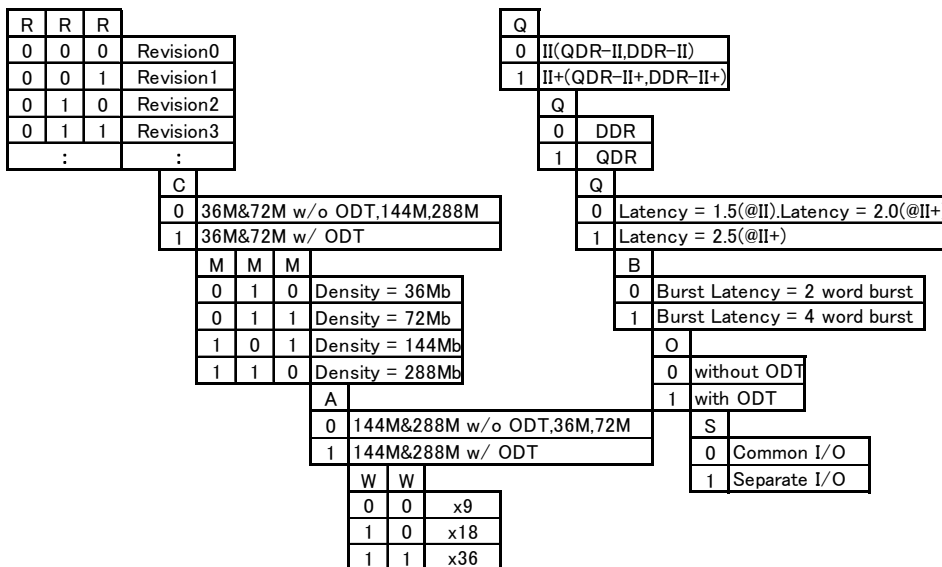

TAP Controller State Diagram

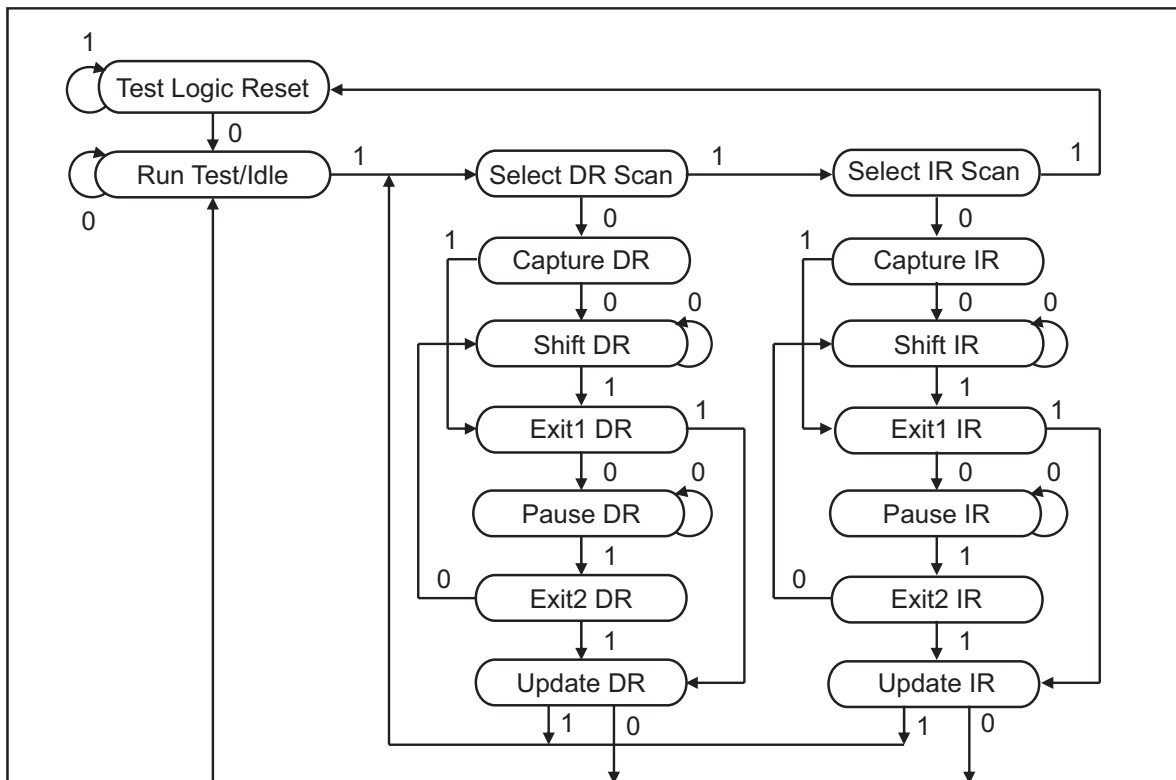

Notes:

The value adjacent to each state transition in this figure represents the signal present at TMS at the time of a rising edge at TCK.

No matter what the original state of the controller, it will enter Test-Logic-Reset when TMS is held high for at least five rising edges of TCK.

Package Dimensions and Marking Information

Both Pb parts and Pb-free parts are available.

JEITA Package Code	Renesas Code	Previous Code	Mass (typ.)
P-LBGA165-15x17-1.00	PLBG0165FD-B	165FHE-B	0.6g

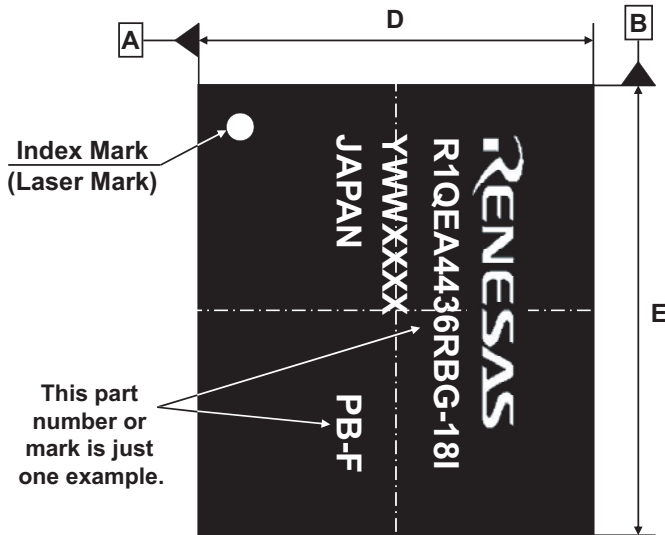

Top View

Marking Information

- 1st row : Vender name (RENESAS)
- 2nd row: Part number
- 3rd row : Y : Year code
WW : Week code
XXXX : Renesas internal use
- 4th row : Country name (JAPAN)
+ "None" --- Pb parts
+ "PB-F" --- Pb-free parts

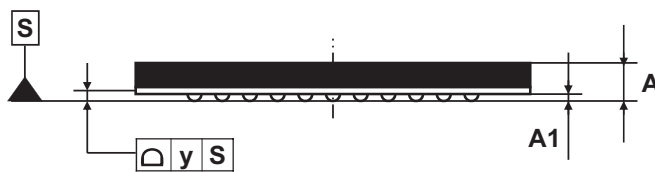

Side View

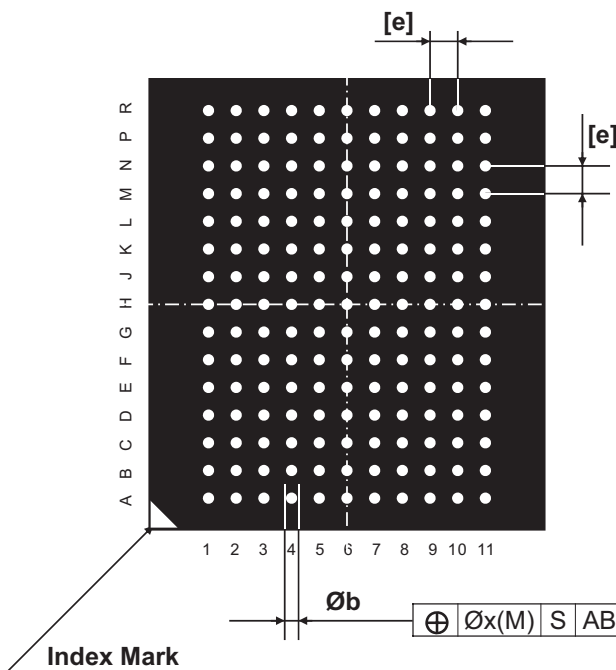

Bottom View

Reference Symbol	Dimension in mm		
	Min	Nom	Max
D	14.9	15.0	15.1
E	16.9	17.0	17.1
A	-	-	1.4
A1	0.31	0.36	0.41
[e]	-	1.0	-
b	0.45	0.5	0.6
x	-	-	0.2
y	-	-	0.15

Revision History	R1QEA4436RBG,R1QEA4418RBG
-------------------------	----------------------------------

Rev.	Date	Description	
		Page	Summary
Rev.1.00	'13.10,21	-	New Datasheet.
Rev.2.00	'14.08,01	P16	Modification : DC Characteristics ,Spec of I _{DD} and I _{SB1} .

QDR RAMs and Quad Data Rate RAMs comprise a new family of products developed by Cypress Semiconductor, and Renesas Electronics Corporation.
<http://www.qdrconsortium.org/>

The information contained herein is subject to change without notice.

Notice

1. Descriptions of circuits, software and other related information in this document are provided only to illustrate the operation of semiconductor products and application examples. You are fully responsible for the incorporation of these circuits, software, and information in the design of your equipment. Renesas Electronics assumes no responsibility for any losses incurred by you or third parties arising from the use of these circuits, software, or information.
2. Renesas Electronics has used reasonable care in preparing the information included in this document, but Renesas Electronics does not warrant that such information is error free. Renesas Electronics assumes no liability whatsoever for any damages incurred by you resulting from errors in or omissions from the information included herein.
3. Renesas Electronics does not assume any liability for infringement of patents, copyrights, or other intellectual property rights of third parties by or arising from the use of Renesas Electronics products or technical information described in this document. No license, express, implied or otherwise, is granted hereby under any patents, copyrights or other intellectual property rights of Renesas Electronics or others.
4. You should not alter, modify, copy, or otherwise misappropriate any Renesas Electronics product, whether in whole or in part. Renesas Electronics assumes no responsibility for any losses incurred by you or third parties arising from such alteration, modification, copy or otherwise misappropriation of Renesas Electronics product.
5. Renesas Electronics products are classified according to the following two quality grades: "Standard" and "High Quality". The recommended applications for each Renesas Electronics product depends on the product's quality grade, as indicated below.
"Standard": Computers; office equipment; communications equipment; test and measurement equipment; audio and visual equipment; home electronic appliances; machine tools; personal electronic equipment; and industrial robots etc.
"High Quality": Transportation equipment (automobiles, trains, ships, etc.); traffic control systems; anti-disaster systems; anti-crime systems; and safety equipment etc.
Renesas Electronics products are neither intended nor authorized for use in products or systems that may pose a direct threat to human life or bodily injury (artificial life support devices or systems, surgical implantations etc.), or may cause serious property damages (nuclear reactor control systems, military equipment etc.). You must check the quality grade of each Renesas Electronics product before using it in a particular application. You may not use any Renesas Electronics product for any application for which it is not intended. Renesas Electronics shall not be in any way liable for any damages or losses incurred by you or third parties arising from the use of any Renesas Electronics product for which the product is not intended by Renesas Electronics.
6. You should use the Renesas Electronics products described in this document within the range specified by Renesas Electronics, especially with respect to the maximum rating, operating supply voltage range, movement power voltage range, heat radiation characteristics, installation and other product characteristics. Renesas Electronics shall have no liability for malfunctions or damages arising out of the use of Renesas Electronics products beyond such specified ranges.
7. Although Renesas Electronics endeavors to improve the quality and reliability of its products, semiconductor products have specific characteristics such as the occurrence of failure at a certain rate and malfunctions under certain use conditions. Further, Renesas Electronics products are not subject to radiation resistance design. Please be sure to implement safety measures to guard them against the possibility of physical injury, and injury or damage caused by fire in the event of the failure of a Renesas Electronics product, such as safety design for hardware and software including but not limited to redundancy, fire control and malfunction prevention, appropriate treatment for aging degradation or any other appropriate measures. Because the evaluation of microcomputer software alone is very difficult, please evaluate the safety of the final products or systems manufactured by you.
8. Please contact a Renesas Electronics sales office for details as to environmental matters such as the environmental compatibility of each Renesas Electronics product. Please use Renesas Electronics products in compliance with all applicable laws and regulations that regulate the inclusion or use of controlled substances, including without limitation, the EU RoHS Directive. Renesas Electronics assumes no liability for damages or losses occurring as a result of your noncompliance with applicable laws and regulations.
9. Renesas Electronics products and technology may not be used for or incorporated into any products or systems whose manufacture, use, or sale is prohibited under any applicable domestic or foreign laws or regulations. You should not use Renesas Electronics products or technology described in this document for any purpose relating to military applications or use by the military, including but not limited to the development of weapons of mass destruction. When exporting the Renesas Electronics products or technology described in this document, you should comply with the applicable export control laws and regulations and follow the procedures required by such laws and regulations.
10. It is the responsibility of the buyer or distributor of Renesas Electronics products, who distributes, disposes of, or otherwise places the product with a third party, to notify such third party in advance of the contents and conditions set forth in this document, Renesas Electronics assumes no responsibility for any losses incurred by you or third parties as a result of unauthorized use of Renesas Electronics products.
11. This document may not be reproduced or duplicated in any form, in whole or in part, without prior written consent of Renesas Electronics.
12. Please contact a Renesas Electronics sales office if you have any questions regarding the information contained in this document or Renesas Electronics products, or if you have any other inquiries.
(Note 1) "Renesas Electronics" as used in this document means Renesas Electronics Corporation and also includes its majority-owned subsidiaries.
(Note 2) "Renesas Electronics product(s)" means any product developed or manufactured by or for Renesas Electronics.



SALES OFFICES

Renesas Electronics Corporation

<http://www.renesas.com>

Refer to "<http://www.renesas.com/>" for the latest and detailed information.

Renesas Electronics America Inc.
2801 Scott Boulevard Santa Clara, CA 95050-2549, U.S.A.
Tel: +1-408-586-6000, Fax: +1-408-588-6130

Renesas Electronics Canada Limited
1101 Nicholson Road, Newmarket, Ontario L3Y 9C3, Canada
Tel: +1-905-898-5441, Fax: +1-905-898-3220

Renesas Electronics Europe Limited
Dukes Meadow, Millboard Road, Bourne End, Buckinghamshire, SL8 5FH, U.K.
Tel: +44-1628-585-100, Fax: +44-1628-585-900

Renesas Electronics Europe GmbH
Arcadiastrasse 10, 40472 Düsseldorf, Germany
Tel: +49-211-6503-0, Fax: +49-211-6503-1327

Renesas Electronics (China) Co., Ltd.
Room 1709, Quantum Plaza, No.27 ZhiChunLu Haidian District, Beijing 100191, P.R.China
Tel: +86-10-8235-1155, Fax: +86-10-8235-7679

Renesas Electronics (Shanghai) Co., Ltd.
Unit 301, Tower A, Central Towers, 555 Langao Road, Putuo District, Shanghai, P. R. China 200333
Tel: +86-21-2226-0888, Fax: +86-21-2226-0999

Renesas Electronics Hong Kong Limited
Unit 1601-1613, 16/F., Tower 2, Grand Century Place, 193 Prince Edward Road West, Mongkok, Kowloon, Hong Kong
Tel: +852-2265-6688, Fax: +852 2886-9022/9044

Renesas Electronics Taiwan Co., Ltd.
13F, No. 363, Fu Shing North Road, Taipei 10543, Taiwan
Tel: +886-2-8175-9600, Fax: +886 2-8175-9670

Renesas Electronics Singapore Pte. Ltd.
80 Bendemeer Road, Unit #06-02 Hyflux Innovation Centre, Singapore 339949
Tel: +65-6213-0200, Fax: +65-6213-0300

Renesas Electronics Malaysia Sdn.Bhd.
Unit 906, Block B, Menara Amcorp, Amcorp Trade Centre, No. 18, Jln Persiaran Barat, 46050 Petaling Jaya, Selangor Darul Ehsan, Malaysia
Tel: +60-3-7955-9390, Fax: +60-3-7955-9510

Renesas Electronics Korea Co., Ltd.
12F., 234 Teheran-ro, Gangnam-Ku, Seoul, 135-920, Korea
Tel: +82-2-558-3737, Fax: +82-2-558-5141