

### GENERAL DESCRIPTION

The SGM9114 is a single rail-to-rail 5th-order output reconstruction filter with a -3dB bandwidth of 8MHz and 35V/ $\mu$ s slew rate. Operating from single power supply ranging from 3.0V to 5.5V and sinking an ultra-low 6mA quiescent current, the SGM9114 is ideally suited for low power, battery-operated applications.

SGM9114 employs an internal level shift circuit that avoids sync-pulse clipping and allows DC-coupled output. If AC coupling is preferred, the SGM9114 offers a sag-correction feature that significantly reduces the size of the output coupling capacitor.

SGM9114 has a power-down disable feature that reduces the supply current to 0.1 $\mu$ A, dramatically reducing power consumption and prolonging battery life.

It operates over an ambient temperature range of -40°C to +85°C.

### BLOCK DIAGRAM

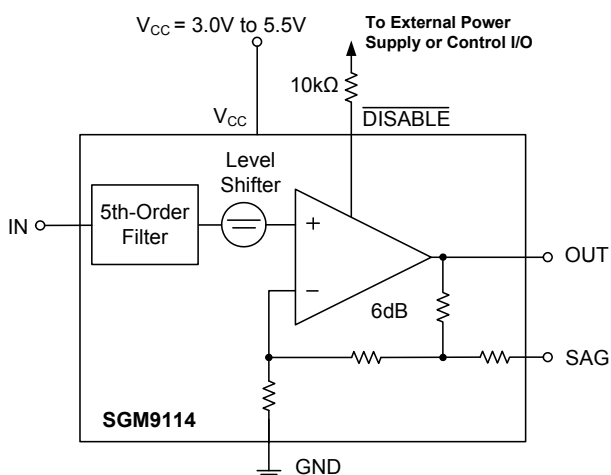

#### NOTES:

1. A 10k $\Omega$  resistor must be serially connected to  $\overline{\text{DISABLE}}$  pin.
2. Power supply  $V_{CC}$  must be sequenced on first before input video signals.

### FEATURES

- **Excellent Video Performance**
- **5th-Order Reconstruction Filter**
- **Internal Gain: 6dB**
- **Rail-to-Rail Output**
- **SAG Correction Reduces AC Coupling Capacitor Size**
- **Input Voltage Range Includes Ground**
- **AC- and DC-Coupled Input**
- **Single Power Supply: 3.0V to 5.5V**
- **Low Power**
  - 6mA Typical Supply Current
  - 0.1 $\mu$ A Typical Supply Current when Disabled
- **Available in Green SOT-23-6 Package**
- **-40°C to +85°C Operating Temperature Range**

### APPLICATIONS

Video Amplifiers  
 Cable and Satellite Set-Top Boxes  
 Communication Devices  
 Video on Demand  
 Portable and Handheld Products  
 Personal Video Recorders  
 DVD Players  
 HDTV

**PACKAGE/ORDERING INFORMATION**

MODEL	PACKAGE DESCRIPTION	SPECIFIED TEMPERATURE RANGE	ORDERING NUMBER	PACKAGE MARKING	PACKING OPTION
SGM9114	SOT-23-6	-40°C to +85°C	SGM9114YN6G/TR	S07XX	Tape and Reel, 3000

NOTE: XX = Date Code.

Green (RoHS & HSF): SG Micro Corp defines "Green" to mean Pb-Free (RoHS compatible) and free of halogen substances. If you have additional comments or questions, please contact your SGMICRO representative directly.

**MARKING INFORMATION**

**S07 X X**

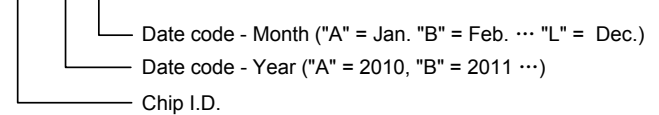

For example: S07FA (2015, January)

**ABSOLUTE MAXIMUM RATINGS**

Input Voltage Range ..... GND - 0.3V to  $V_{CC} + 0.3V$   
 Supply Voltage,  $V_{CC}$  ..... 6.0V  
 Junction Temperature ..... 150°C  
 Storage Temperature Range ..... -65°C to +150°C  
 Lead Temperature (Soldering, 10s) ..... 260°C  
 ESD Susceptibility  
 HBM ..... 8000V  
 MM ..... 400V  
 CDM ..... 2000V

**RECOMMENDED OPERATING CONDITIONS**

Operating Voltage Range ..... 3.0V to 5.5V  
 Operating Temperature Range ..... -40°C to +85°C

**OVERSTRESS CAUTION**

Stresses beyond those listed may cause permanent damage to the device. Functional operation of the device at these or any other conditions beyond those indicated in the operational section of the specification is not implied. Exposure to absolute maximum rating conditions for extended periods may affect reliability.

**ESD SENSITIVITY CAUTION**

This integrated circuit can be damaged by ESD if you don't pay attention to ESD protection. SGMICRO recommends that all integrated circuits be handled with appropriate precautions. Failure to observe proper handling and installation procedures can cause damage. ESD damage can range from subtle performance degradation to complete device failure. Precision integrated circuits may be more susceptible to damage because very small parametric changes could cause the device not to meet its published specifications.

**DISCLAIMER**

SG Micro Corp reserves the right to make any change in circuit design, specification or other related things if necessary without notice at any time.

**PIN CONFIGURATION**

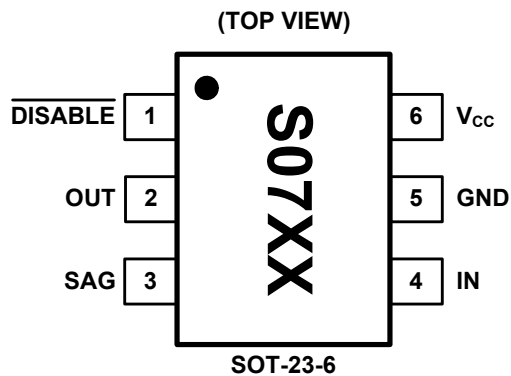

**PIN DESCRIPTION**

PIN	NAME	FUNCTION
1	$\overline{\text{DISABLE}}$	Shutdown Input.
2	OUT	Signal Output.
3	SAG	SAG Correction.
4	IN	Signal Input.
5	GND	Ground.
6	V <sub>CC</sub>	Power Supply.

SGM9114

**ELECTRICAL CHARACTERISTICS**

(At  $V_{CC} = 5V$ ,  $R_L = 150\Omega$  connected to GND,  $V_{IN} = 1V_{PP}$  and  $C_{IN} = 0.1\mu F$ , output AC-coupled, referenced to 400kHz, unless otherwise noted.)

PARAMETER	CONDITIONS	TEMP	MIN	TYP	MAX	UNITS
<b>INPUT CHARACTERISTICS</b>						
Output Level Shift Voltage ( $V_{OLS}$ )	$V_{IN} = 0V$ , No load	+25°C		340	570	mV
		-40°C to +85°C			675	
Input Voltage Clamp ( $V_{CLAMP}$ )	$I_{IN} = -3.5mA$	+25°C	-285	-210		mV
		-40°C to +85°C	-390			
Clamp Charge Current	$V_{IN} = V_{CLAMP} - 100mV$	+25°C	-5.5	-4.8		mA
		-40°C to +85°C	-6.8			
Clamp Discharge Current	$V_{IN} = 500mV$	+25°C		1.9	2.7	$\mu A$
		-40°C to +85°C			3.2	
Voltage Gain ( $A_V$ )	$R_L = 150\Omega$	+25°C	5.6	6	6.4	dB
		-40°C to +85°C	5.55		6.45	
<b>OUTPUT CHARACTERISTICS</b>						
Output Voltage High Swing	$V_{IN} = 3.0V$ , $R_L = 150\Omega$ to GND	+25°C	4.6	4.79		V
		-40°C to +85°C	4.5			
Output Short-Circuit Current ( $I_{SC}$ )	$V_{IN} = 1.5V$ , Out shorted to GND through 10 $\Omega$	+25°C	80	95		mA
		-40°C to +85°C	77			
	$V_{IN} = 0.5V$ , Out shorted to $V_{CC}$ through 10 $\Omega$	+25°C		-102	-87	mA
		-40°C to +85°C			-78	
<b>POWER SUPPLY</b>						
Operating Voltage Range ( $V_{CC}$ )		+25°C	3.0		5.5	V
Power Supply Rejection Ratio (PSRR)	$V_{CC} = 3.5V$ to 5.0V	+25°C	40	50		dB
		-40°C to +85°C	38			
Quiescent Current ( $I_Q$ )	$V_{IN} = 0.5V$ , $\overline{DISABLE} = V_{CC}$ , $R_L = 0\Omega$	+25°C		6	9.5	mA
		-40°C to +85°C			11.5	
Supply Current when Disabled	$\overline{DISABLE} = 0V$	+25°C		0.1	18	$\mu A$
		-40°C to +85°C			20	
<b>DYNAMIC PERFORMANCE</b>						
-0.1dB Bandwidth		+25°C		6		MHz
-3dB Bandwidth		+25°C		8		MHz
Filter Response (Normalized Gain)	$f_{IN} = 27MHz$	+25°C		47		dB
Slew Rate	2V Output step, 80% to 20%	+25°C		35		V/ $\mu s$
Differential Gain Error (DG)	PAL DC-coupled	+25°C		0.85		%
	PAL AC-coupled	+25°C		0.85		%
Differential Phase Error (DP)	PAL DC-coupled	+25°C		1		°
	PAL AC-coupled	+25°C		1.4		°
Group Delay Variation (D/DT)	Difference between 400kHz and 6.5MHz	+25°C		28		ns
Fall Time	2V Output step, 80% to 20%	+25°C		34		ns
Rise Time	2V Output step, 80% to 20%	+25°C		33		ns
<b>POWER-DOWN DISABLE</b>						
$\overline{DISABLE}$ (Logic-Low Threshold)	$V_{CC} = 5V$	+25°C			0.4	V
$\overline{DISABLE}$ (Logic-High Threshold)	$V_{CC} = 5V$	+25°C	1.2			V

TYPICAL PERFORMANCE CHARACTERISTICS

At  $V_{CC} = 5V$ ,  $T_A = +25^\circ C$ ,  $R_L = 150\Omega$ , output AC-coupled, unless otherwise noted.

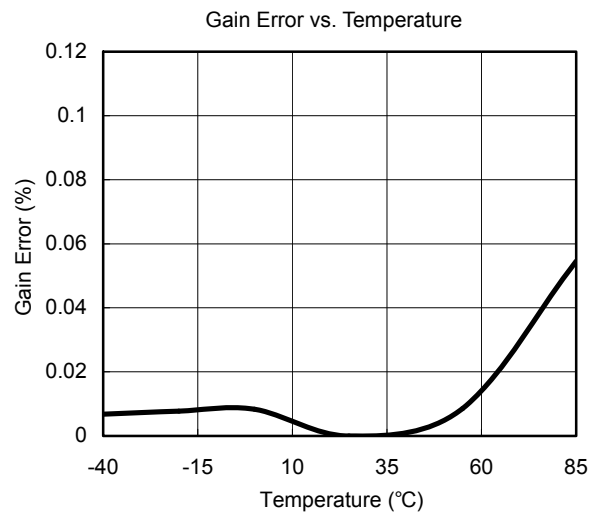
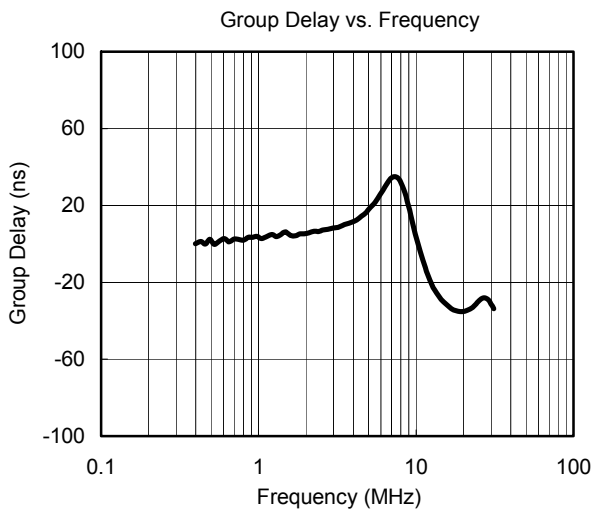
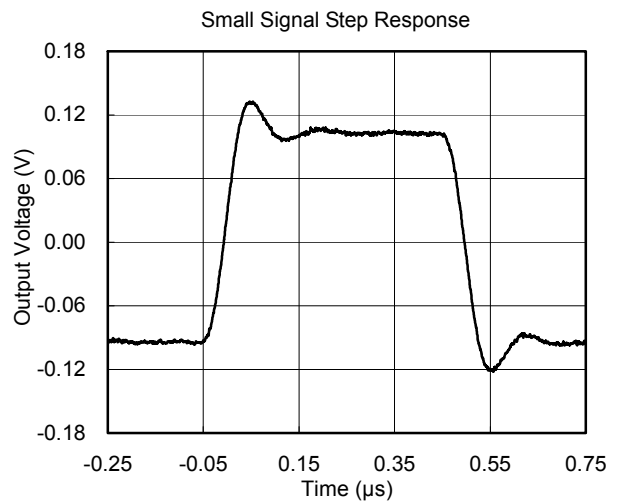
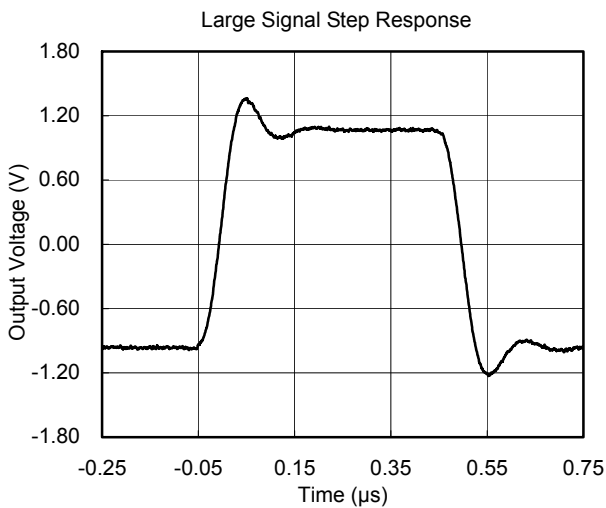
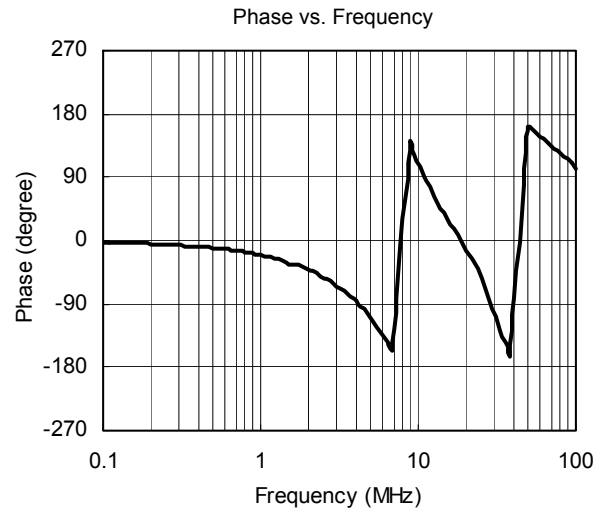
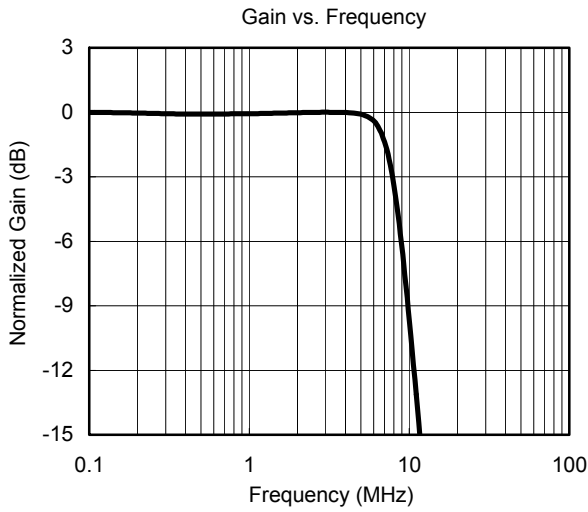

TYPICAL PERFORMANCE CHARACTERISTICS

At  $V_{CC} = 5V$ ,  $T_A = +25^\circ C$ ,  $R_L = 150\Omega$ , output AC-coupled, unless otherwise noted.

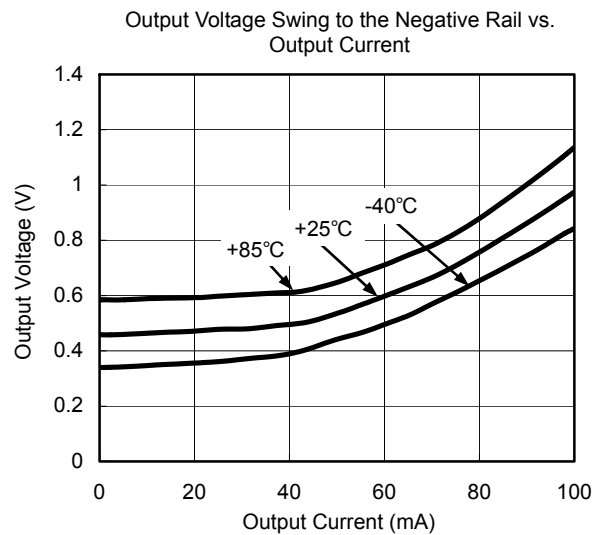
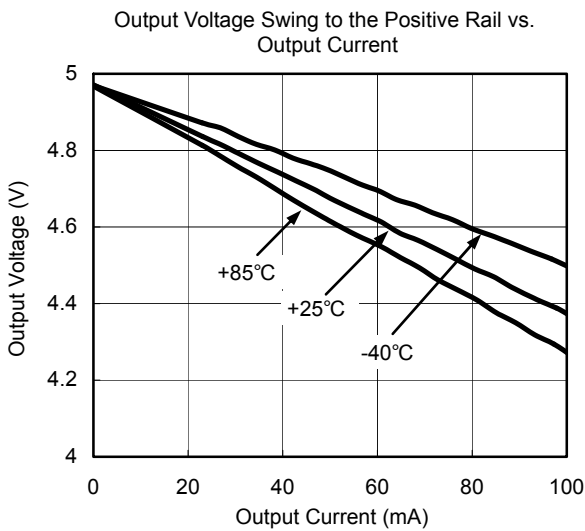
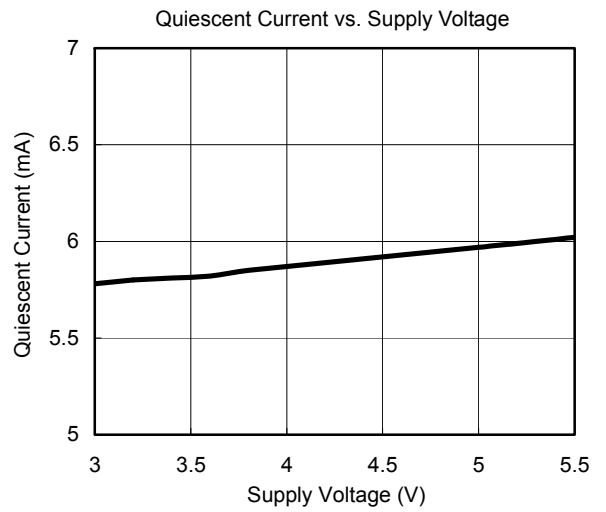
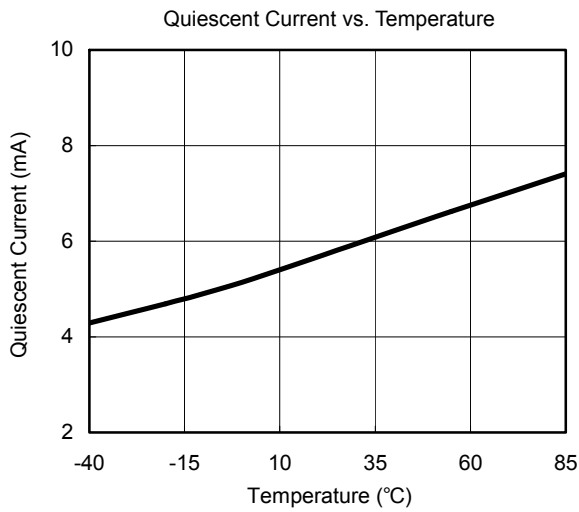

### APPLICATION INFORMATION

The SGM9114 low cost, integrated, 5th-order video filter is intended to replace passive LC filters and drivers in low voltage portable video applications.

The SGM9114 input must be AC-coupled because the input capacitor stores the clamp voltage. It needs a typical value of 0.1 $\mu$ F for the input clamp to meet the Line Droop specification. The SGM9114 output can drive an AC- or DC-coupled doubly terminated coax (150 $\Omega$ ) load (see Figure 1). DC coupling the output removes the need for an expensive and large output coupling capacitor (see Figure 2). If an AC-coupled output is needed, the SAG correction circuit can be used to reduce the AC output coupling capacitor value.

Offering SAG correction, fixed gain of 6dB, and a 5th-order low pass filter in a tiny space saving package makes the SGM9114 well suited for space sensitive applications such as digital cameras, cellular phones and other portable devices.

#### Enable/Shutdown

The SGM9114 has a shutdown feature that disables the output and reduces the quiescent current to 0.1 $\mu$ A. This feature is particularly useful in portable applications, such as video cameras, hand held gaming devices and cellular phones, where video filtering and driving capability are required.

#### Internal Sync Clamp

The typical embedded video DAC operates from a ground referenced single supply. This becomes an issue because the lower level of the sync pulse output may be at a 0V reference level to some positive level. The problem is that presenting a 0V input to most single supply driven amplifiers will saturate the output stage of the amplifier, resulting in a clipped sync tip and degrading the video image. A larger positive reference may offset the input above its positive range.

The SGM9114 features an internal sync clamp and offset function to level shift the entire video signal to the best level before it reaches the input of the amplifier stage. These features are also helpful to avoid saturation of the output stage of the amplifier by setting the signal closer to the optimal voltage range.

The typical application of the SGM9114 is shown in Figure 1. The AC-coupled video sync signal is pulled negative by a current source at the input of the comparator amplifier. When the sync tip goes below the comparator threshold, the comparator output is driven negative, and the PMOS device turns on, clamping sync tip to near ground signal. The network triggers on the sync tip of video signal.

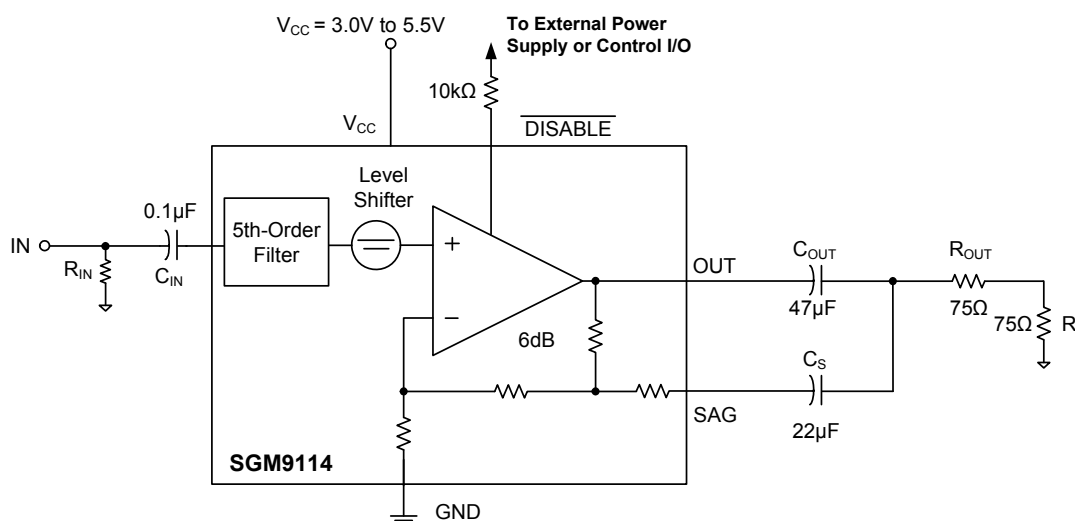

Figure 1. AC-Coupled Input/AC-Coupled Output

### APPLICATION INFORMATION

#### SAG Correction

The SGM9114 can use the SAG configuration if an AC-coupled output video signal is needed. SAG correction refers to the low-frequency compensation for the high pass filter formed by the 150Ω load and the output capacitor. In video applications, the cutoff frequency must be low enough to pass the vertical sync interval to avoid field tilt. This cutoff frequency should be less than 5Hz, and the coupling capacitor must be very large in normal configuration, typically 220μF. In SAG configuration, the SGM9114 removes the need for large coupling capacitors, and instead only requires one 22μF and one 47μF capacitors (Figure 1) to achieve the same performance as the large capacitor.

#### The Sallen Key Low Pass Filter

The Sallen Key in a classic low pass configuration is illustrated in Figure 1. The filter provides a very stable low pass function, and in the case of the SGM9114, a 5th-order roll-off at around 8MHz. The 5th-order function is accomplished with an RC low pass network placed in series with and before the Sallen Key. One pole provided by the RC network and poles two and three provided by the Sallen Key produce a nice 5th-order roll-off at around 8MHz.

#### Layout and Power-Supply Bypassing

The SGM9114 operates from single 3.0V to 5.5V supply. Bypass the supply with a 0.1μF capacitor as close to the pin as possible. It is recommended to use microstrip and stripline techniques to obtain full bandwidth. To ensure that the PC board does not degrade the device's performance, design it for a frequency greater than 1GHz. Pay careful attention to inputs and outputs to avoid large parasitic capacitance. Whether or not you use a constant-impedance board, observe the following design guidelines:

- Do not use IC sockets; they increase parasitic capacitance and inductance.
- Do not use wire-wrap boards; they are too inductive.
- Use surface-mount instead of through-hole components for better, high-frequency performance.
- Use a PC board with at least two layers; it should be as free from voids as possible.
- Keep signal lines as short and as straight as possible. Do not make 90° turns; round all corners.

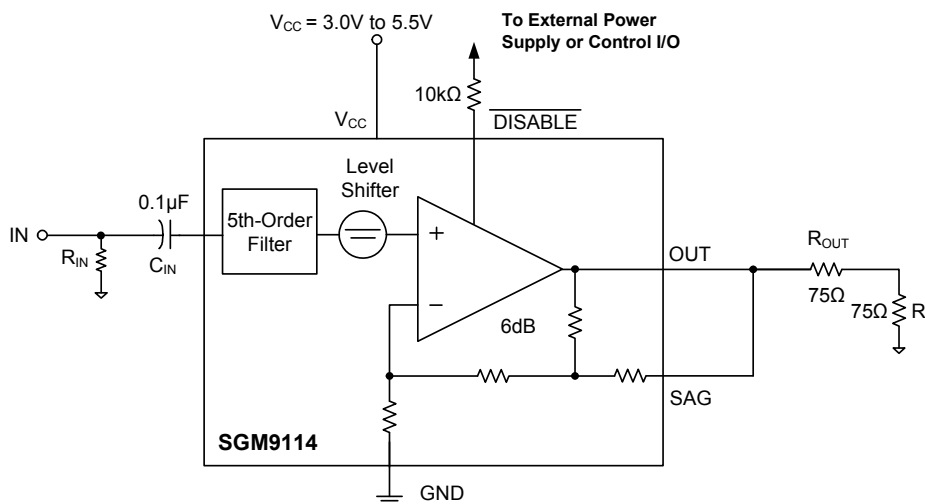

Figure 2. AC-Coupled Input/DC-Coupled Output



# PACKAGE INFORMATION

## PACKAGE OUTLINE DIMENSIONS

### SOT-23-6

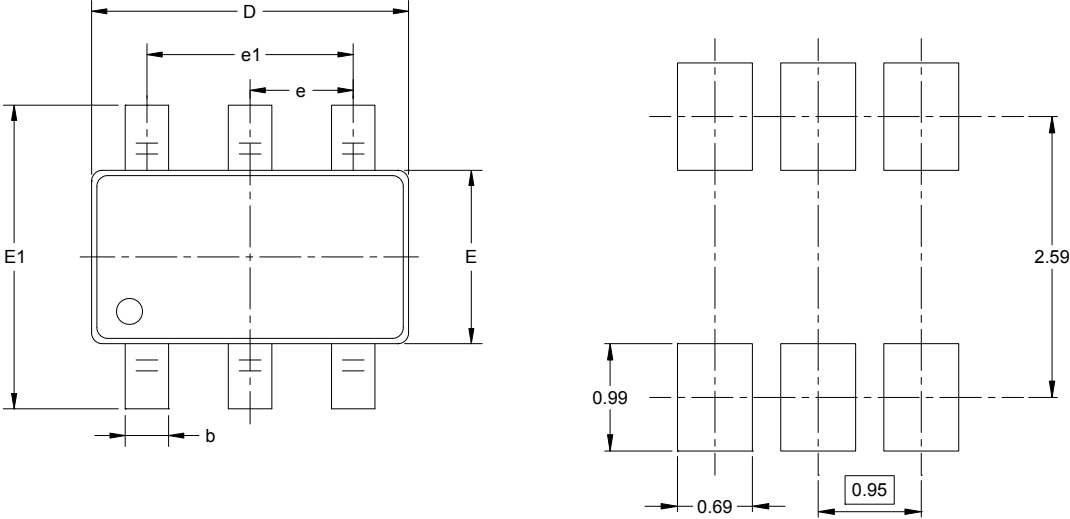

RECOMMENDED LAND PATTERN (Unit: mm)

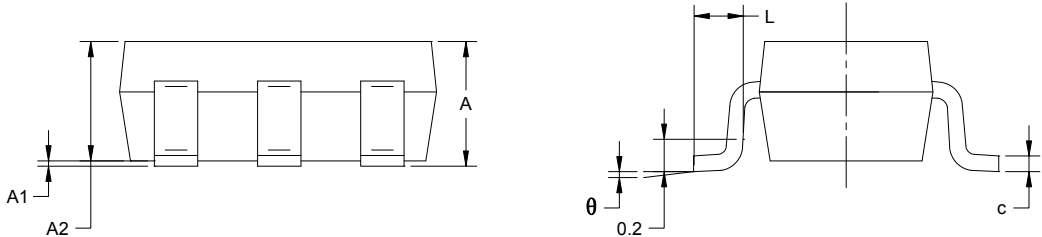

Symbol	Dimensions In Millimeters		Dimensions In Inches	
	MIN	MAX	MIN	MAX
A	1.050	1.250	0.041	0.049
A1	0.000	0.100	0.000	0.004
A2	1.050	1.150	0.041	0.045
b	0.300	0.500	0.012	0.020
c	0.100	0.200	0.004	0.008
D	2.820	3.020	0.111	0.119
E	1.500	1.700	0.059	0.067
E1	2.650	2.950	0.104	0.116
e	0.950 BSC		0.037 BSC	
e1	1.900 BSC		0.075 BSC	
L	0.300	0.600	0.012	0.024
θ	0°	8°	0°	8°

**TAPE AND REEL INFORMATION**

**REEL DIMENSIONS**

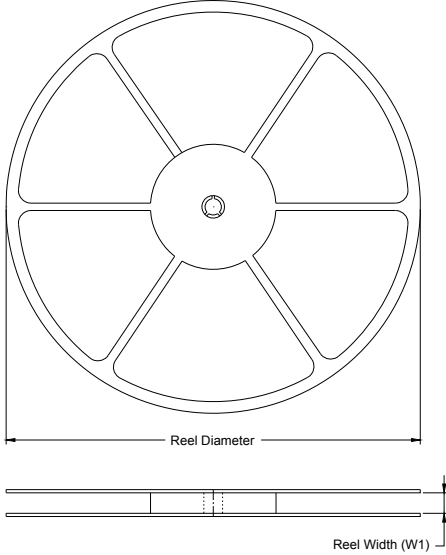

**TAPE DIMENSIONS**

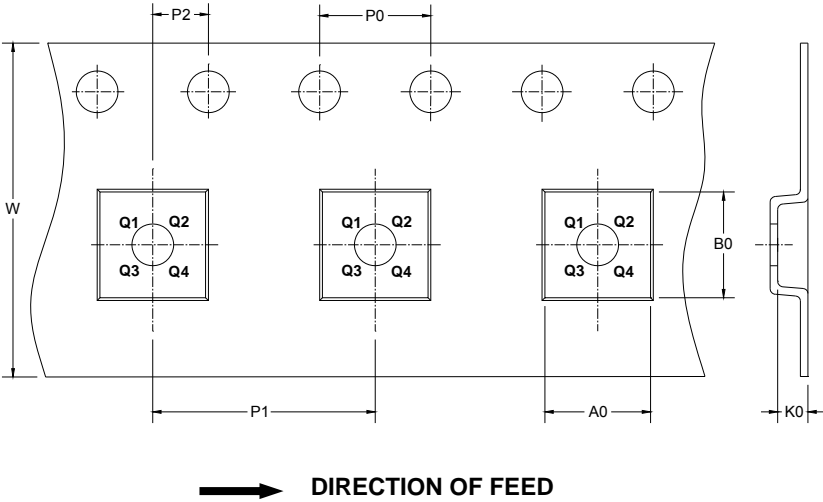

NOTE: The picture is only for reference. Please make the object as the standard.

**KEY PARAMETER LIST OF TAPE AND REEL**

Package Type	Reel Diameter	Reel Width W1 (mm)	A0 (mm)	B0 (mm)	K0 (mm)	P0 (mm)	P1 (mm)	P2 (mm)	W (mm)	Pin1 Quadrant
SOT-23-6	7"	9.5	3.17	3.23	1.37	4.0	4.0	2.0	8.0	Q3

D00001

# PACKAGE INFORMATION

## CARTON BOX DIMENSIONS

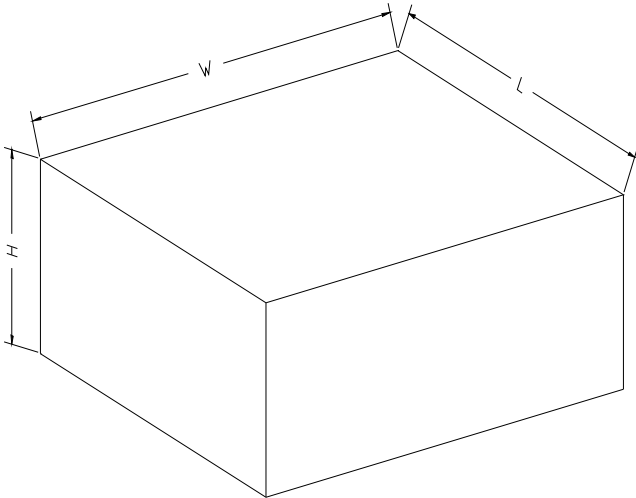

NOTE: The picture is only for reference. Please make the object as the standard.

## KEY PARAMETER LIST OF CARTON BOX

Reel Type	Length (mm)	Width (mm)	Height (mm)	Pizza/Carton
7" (Option)	368	227	224	8
7"	442	410	224	18

D100002