

Zibo Seno Electronic Engineering Co., Ltd.



SF1610CT-SF1660CT



16.0A GLASS PASSIVATED SUPER FAST RECTIFIER

Features

- Glass Passivated Die Construction
- Super-Fast Switching
- Low Forward Voltage Drop
- Low Reverse Leakage Current
- High Surge Current Capability
- Plastic Material has UL Flammability Classification 94V-0

TO-263 (D²PAK)

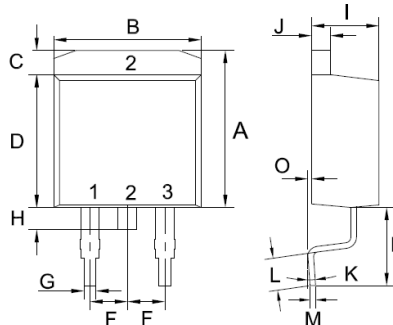

TO-263 (D ² PAK)		
Unit:mm		
DIM	MIN	MAX
A	10.44	10.84
B	9.81	10.21
C	1.44	1.84
D	8.80	9.20
E	4.46	4.66
F	2.44	2.64
G	0.61	1.01
H	0.70	1.30
I	4.27	4.87
J	1.07	1.47
K	0°	8°
L	2.10	2.50
M	0.30	0.46
0	0	0.25

Mechanical Data

- Case: TO-263(D²PAK), Molded Plastic
- Terminals: Plated Leads Solderable per MIL-STD-202, Method 208
- Polarity: See Diagram
- Mounting Position: Any
- **Lead Free: For RoHS / Lead Free Version**

Maximum Ratings and Electrical Characteristics @T_A=25°C unless otherwise specified

Single Phase, half wave, 60Hz, resistive or inductive load.
For capacitive load, derate current by 20%.

Characteristic	SYMBOL	SFB 1610CT	SFB 1620CT	SFB 1630CT	SFB 1640CT	SFB 1650CT	SFB 1660CT	UNIT
Maximum Recurrent Peak Reverse Voltage	V _{RRM}	100	200	300	400	500	600	V
Maximum RMS Voltage	V _{RMS}	70	140	210	280	350	420	V
Maximum DC Blocking Voltage	V _{DC}	100	200	300	400	500	600	V
Maximum Average Forward Rectified Current T _c =100°C	I _{F(AV)}	16.0						A
Peak Forward Surge Current, 8.3ms single Half sine-wave superimposed on rated load (JEDEC method)	I _{FSM}	90						A
Maximum Instantaneous Forward Voltage @ 8.0 A	V _F	1.0		1.3		1.7		V
Maximum DC Reverse Current @T _J =25°C At Rated DC Blocking Voltage @T _J =125°C	I _R	10.0						uA
		250						uA
Maximum Reverse Recovery Time (Note 1)	T _{rr}	35						nS
Typical junction Capacitance (Note 2)	C _J	170			130			pF
Typical Thermal Resistance (Note 3)	R _{θJC}	3.5						°CW
Operating Junction and Storage Temperature Range	T _J , T _{STG}	-55 to +150						°C

Note: 1. Measured with I_F = 0.5A, I_R = 1.0A, I_{RR} = 0.25A.
2. Measured at 1.0 MHz and applied reverse voltage of 4.0V D.C.

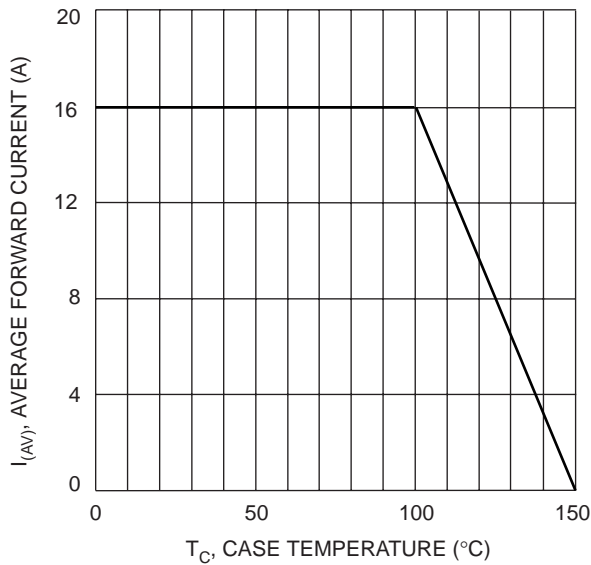

Fig. 1 Forward Current Derating Curve

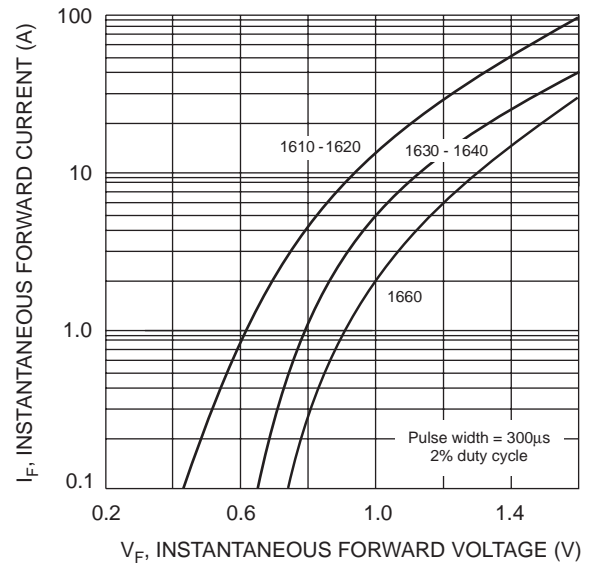

Fig. 2 Typical Forward Characteristics

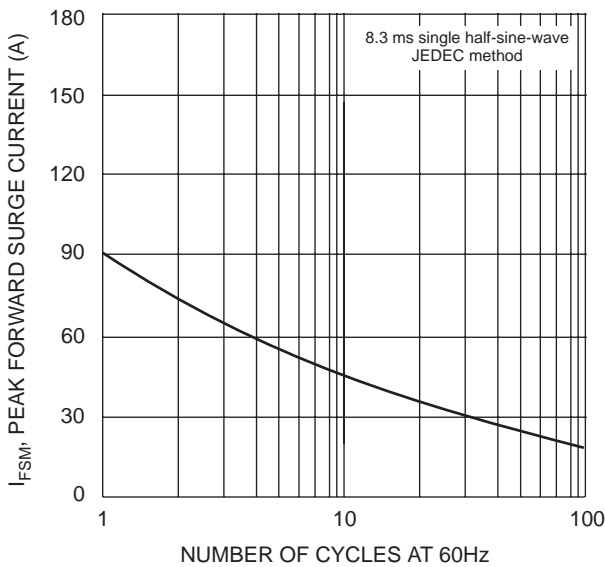

Fig. 3 Max Non-Repetitive Surge Current

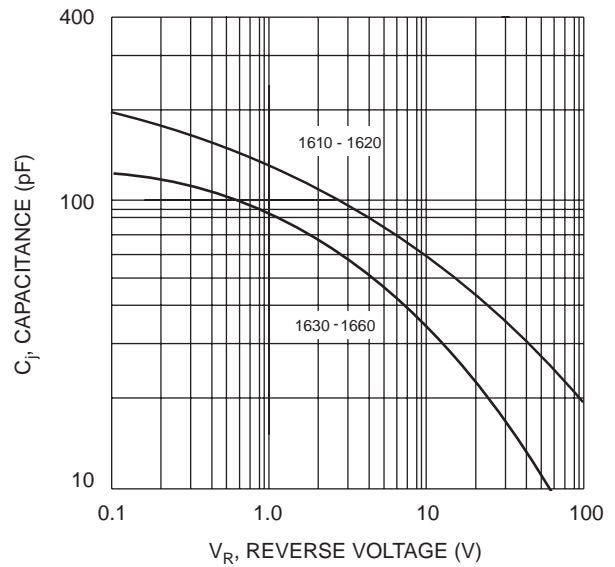

Fig. 4 Typical Junction Capacitance