

Si88xxxISO-EVB USER'S GUIDE

Description

This document describes the operation of the Si88xxxISO-EVB.

Kit Contents

The Si88xxxISO Evaluation Kit contains the following items:

- Si88xxxISO-EVB
- Si88241ED-IS installed on the evaluation board.

Si88xxxISO-EVB Overview

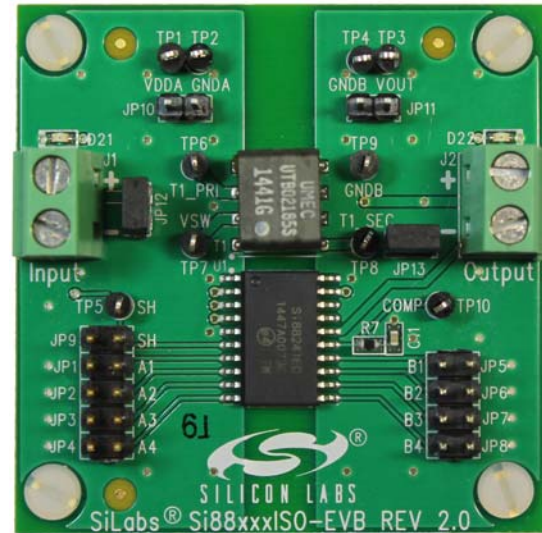

Hardware Overview and Setup

Power the EVB by applying a 3.0 to 5.5 V dc supply to terminal block J1. The isolated output is available at terminal block J2. Test points for these are available at the upper edge of the EVB.

The default EVB configuration has the header JP13 shorted, so the dc-dc output powers the VDDDB supply (U1 pin 19) of the Si88241ED-IS. The acceptable input voltage to the VDDDB supply pin is 3.0 to 5.5 V. If the user chooses to generate an output voltage outside this voltage range, the jumper at JP13 must be removed and a separate supply source connected to VDDDB through JP13.

To measure input supply current, clip a differential probe across JP12 to access each side of sense resistor R20.

The SH input (U1 pin 7) disables the dc-dc converter function. Install a jumper across JP9 to pull the SH input high and disable the dc-dc converter. If interfacing to an external controller board through the JP9 header, the controller must drive SH low for normal operation and high to disable the dc-dc.

The EVB has a series of headers for connecting to each digital channel. The inside conductor of each 2x1 header is connected to the device pin and the outer conductor is tied to ground through a protection resistor. Connect to each side of the Si88xxxISO-EVB to external controllers through a two-row ribbon cables with one row grounded.

Si88xxxISO-EVB

1. Si88xxxISO-EVB Schematics

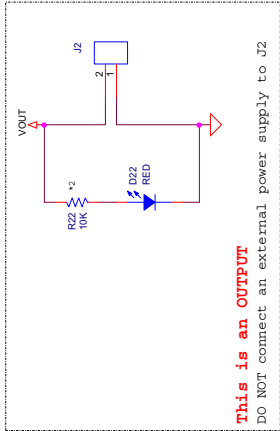
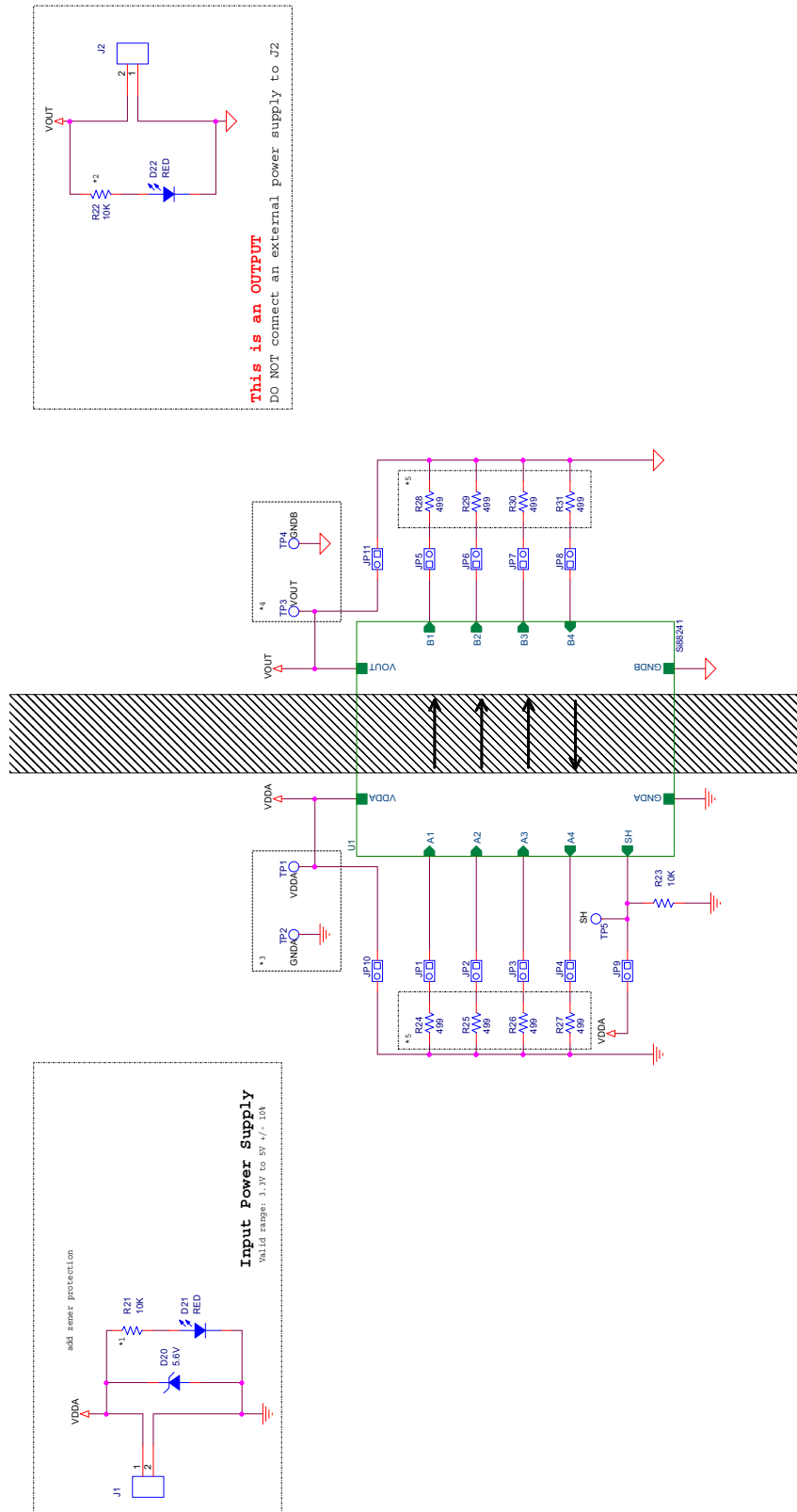

This is an OUTPUT
DO NOT connect an external power supply to J2

Figure 1. Si88xxxISO-EVB Schematic (1 of 2)

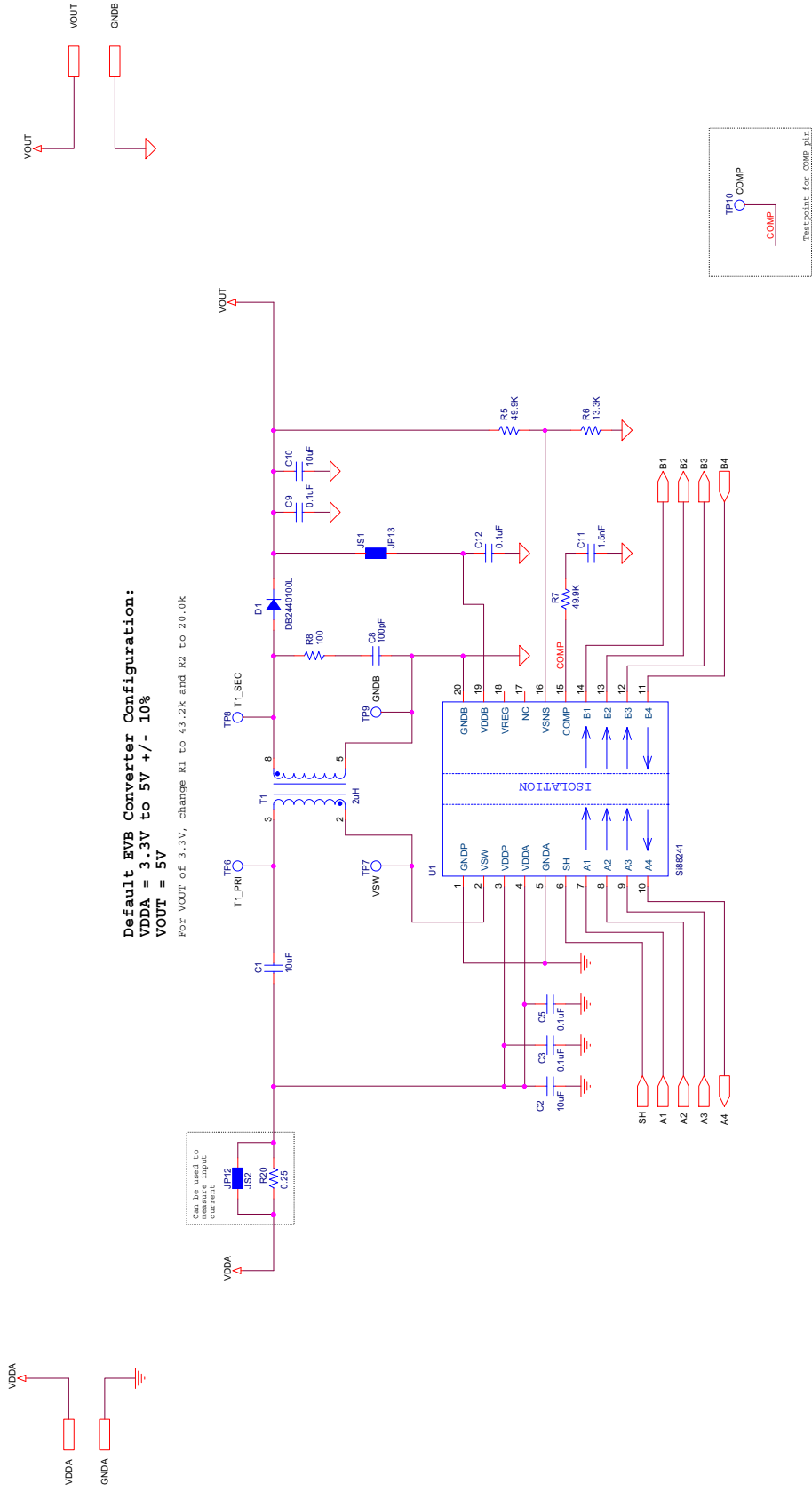

Figure 2. Si88xxxISO-EVB Schematic (2 of 2)

Si88xxxISO-EVB

2. Si88xxxISO-EVB Layout

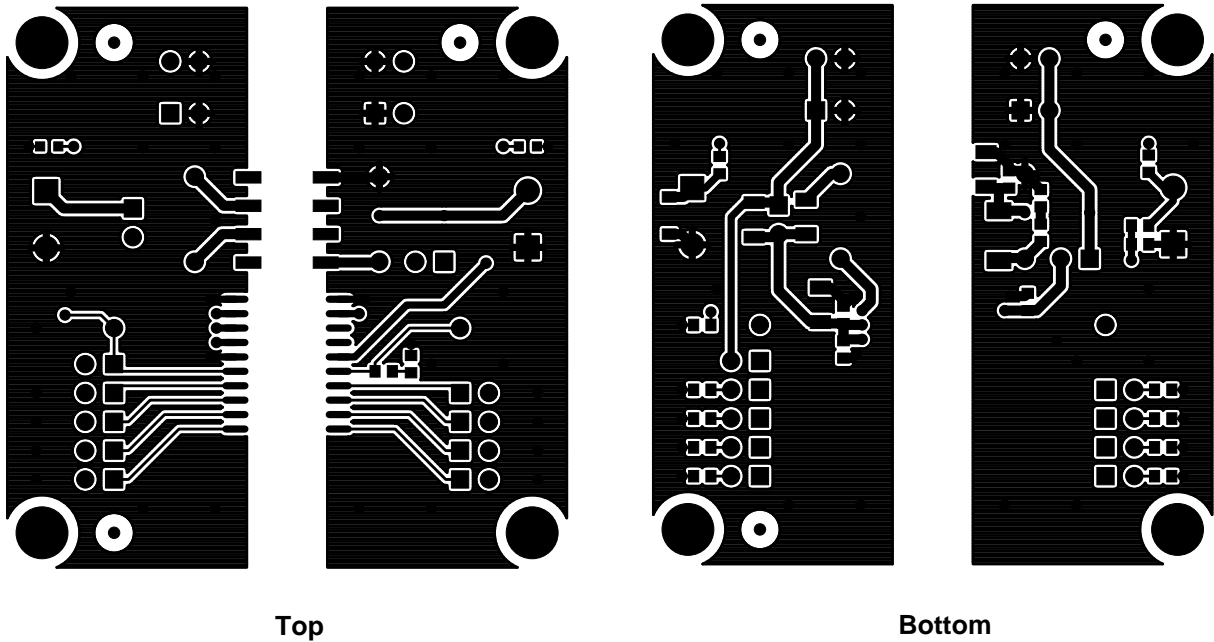
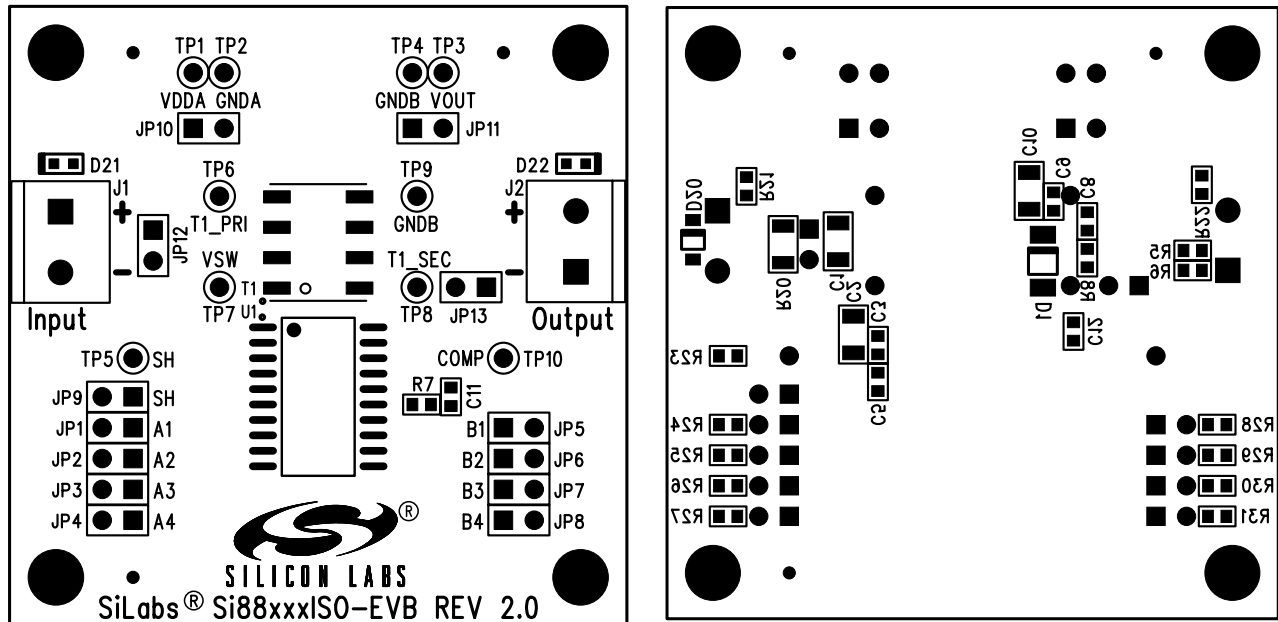

Figure 3. Si88xxxISO-EVB Layout

3. Bill of Materials

Table 1. Si88xxxISO-EVB Bill of Materials

Part Reference	Description	Mfr	Mfr Part Number
C1 C2 C10	CAP, 10 μ F, 10 V, \pm 10%, X7R, 1206	Venkel	C1206X7R100-106K
C3 C5 C9 C12	CAP, 0.1 μ F, 10 V, \pm 10%, X7R, 0603	Venkel	C0603X7R100-104K
C8	CAP, 100 pF, 50 V, \pm 10%, X7R, 0603	Venkel	C0603X7R500-101K
C11	CAP, 1.5 nF, 16 V, \pm 10%, X7R, 0603	Venkel	C0603X7R160-152K
D1	DIO, FAST, 40 V, 1.0A, SOD-128	Panasonic	DB2440100L
D20	DIO, ZENER, 5.6 V, 500 mW, SOD123	On Semi	MMSZ5232BT1
D21 D22	LED, RED, 631 nM, 20 mA, 2 V, 54mcd, 0603	Lite-On	LTST-C190KRKT
J1 J2	CONN, TERM BLOCK 2POS, 5MM PCB	Phoenix Contact	1729018
JP1 JP2 JP3 JP4 JP5 JP6 JP7 JP8 JP9 JP10 JP11 JP12 JP13	Header, 2x1, 0.1in pitch, Tin Plated	Samtec	TSW-102-07-T-S
JS1 JS2	Shunt, 1x2, 0.1in pitch, Tin plating	Samtec	SNT-100-BK-T
MH1 MH2 MH3 MH4	HDW, Screw, 4-40 x 1/4" Pan Head, Slotted, Nylon	Richco Plastic Co	NSS-4-4-01
R5 R7	RES, 49.9K, 1/10W, \pm 1%, ThickFilm, 0603	Venkel	CR0603-10W-4992F
R6	RES, 13.3K, 1/16W, \pm 1%, ThickFilm, 0603	Venkel	CR0603-16W-1332F
R8	RES, 100 Ω , 1/16W, \pm 1%, ThickFilm, 0603	Venkel	CR0603-16W-1000F
R20	RES, 0.25 Ω , 1/2W, \pm 1%, ThickFilm, 1206	Venkel	LCR1206-R250J
R21 R22 R23	RES, 10K, 1/10W, \pm 5%, ThickFilm, 0603	Venkel	CR0603-10W-103J
R24 R25 R26 R27 R28 R29 R30 R31	RES, 499 Ω , 1/10W, \pm 1%, ThickFilm, 0603	Venkel	CR0603-10W-4990F
SO1 SO2 SO3 SO4	HDW, STANDOFF, 1/4" HEX, 4-40x3/4", NYLON	Keystone	1902D
T1	TRANSFORMER, POWER, FLYBACK, 2.0 μ H PRIMARY, 100 nH LEAKAGE, 1:4, 1 TAP, SMT	UMEC	UTB02185S
TP1 TP2 TP3 TP4 TP5 TP6 TP7 TP8 TP9 TP10	TESTPOINT, BLACK, PTH	Kobiconn	151-203-RC
U1	IC, ISOLATOR, DC DC Internal Switch, SH, 4 Digital Ch, SO20 WB	Silicon Labs	Si88241ED-IS

Si88xxxISO-EVB

4. Si88xxxISO-EVB Ordering Guide

Table 2. Si88xxxISO-EVB Ordering Guide

Ordering Part Number (OPN)	Description
Si88xxxISO-KIT	Si88xxx dc-dc digital isolator evaluation board kit

CONTACT INFORMATION

Silicon Laboratories Inc.

400 West Cesar Chavez

Austin, TX 78701

Tel: 1+(512) 416-8500

Fax: 1+(512) 416-9669

Toll Free: 1+(877) 444-3032

Please visit the Silicon Labs Technical Support web page:

<https://www.siliconlabs.com/support/pages/contacttechnicalsupport.aspx>

and register to submit a technical support request.

Patent Notice

Silicon Labs invests in research and development to help our customers differentiate in the market with innovative low-power, small size, analog-intensive mixed-signal solutions. Silicon Labs' extensive patent portfolio is a testament to our unique approach and world-class engineering team.

The information in this document is believed to be accurate in all respects at the time of publication but is subject to change without notice. Silicon Laboratories assumes no responsibility for errors and omissions, and disclaims responsibility for any consequences resulting from the use of information included herein. Additionally, Silicon Laboratories assumes no responsibility for the functioning of undescribed features or parameters. Silicon Laboratories reserves the right to make changes without further notice. Silicon Laboratories makes no warranty, representation or guarantee regarding the suitability of its products for any particular purpose, nor does Silicon Laboratories assume any liability arising out of the application or use of any product or circuit, and specifically disclaims any and all liability, including without limitation consequential or incidental damages. Silicon Laboratories products are not designed, intended, or authorized for use in applications intended to support or sustain life, or for any other application in which the failure of the Silicon Laboratories product could create a situation where personal injury or death may occur. Should Buyer purchase or use Silicon Laboratories products for any such unintended or unauthorized application, Buyer shall indemnify and hold Silicon Laboratories harmless against all claims and damages.

Silicon Laboratories and Silicon Labs are trademarks of Silicon Laboratories Inc.

Other products or brandnames mentioned herein are trademarks or registered trademarks of their respective holders.