

## Features

- EB welded metal strip
- Very high power
- Excellent long term stability
- Low resistance, low TCR
- Low thermal EMF
- RoHS compliant\*

## Applications

- Current sensing
- Voltage division
- Battery management systems
- Power modules
- Frequency converters
- Industrial

# Model CSS2H-2512 Series Current Sense Resistor

### Electrical Characteristics

Characteristic	Model CSS2H-2512 Series	
	Resistance Range / Power Rating @ 70 °C* / Power Rating @ 130 °C*	CSS2H-2512R-L500x
	CSS2H-2512R-1L00x	1.0 mΩ / 5 W / 3 W
	CSS2H-2512K-2L00x	2.0 mΩ / 5 W / 3 W
	CSS2H-2512K-3L00x	3.0 mΩ / 4 W / 2 W
Operating Temperature Range	-55 to +170 °C	
TCR - Resistive Alloy	≤+50 PPM/°C (20~60 °C)	
Resistance Tolerance	±1 %, ±5 %	

\* Terminal temperature

### Environmental Characteristics

Characteristic	Test Condition	ΔR Max.
Thermal Shock	-55 to +150 °C / 100 Cycles	0.50 %
Resistance to Soldering Heat	+260 °C / 10 Seconds	0.50 %
High Temperature Exposure	+170 °C / 100 Hours	1.00 %
Low Temperature Storage	-65 °C / 24 Hours	0.10 %
Biased Humidity Test	+85 °C, 85 %R.H., 100 Hours	0.50 %
Moisture Resistance	10 Days with Cold Shock, No Load	0.20 %
Mechanical Shock	100 g, 6 ms half sine	0.20 %
Vibration, High Frequency	20 g, 10-2000 Hz	0.20 %
Load Life	1000 Hours Derated Curve at 130 °C	1.00 %

### How to Order

Model **CSS 2H - 2512 R - L500 J**

Model \_\_\_\_\_  
 No. of Terminals & Style \_\_\_\_\_  
 Size \_\_\_\_\_  
 Material Type \_\_\_\_\_  
 (See Part Number Table)  
 Resistance Code (milliohms) \_\_\_\_\_  
 "L" represents decimal point  
 (examples: L500 = .500 milliohms;  
 1L00 = 1.00 milliohms)  
 Resistance Tolerance \_\_\_\_\_  
 F = ±1 %  
 J = ±5 %

### Typical Part Marking

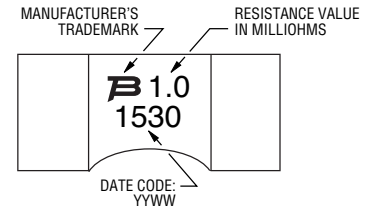

### Product Dimensions

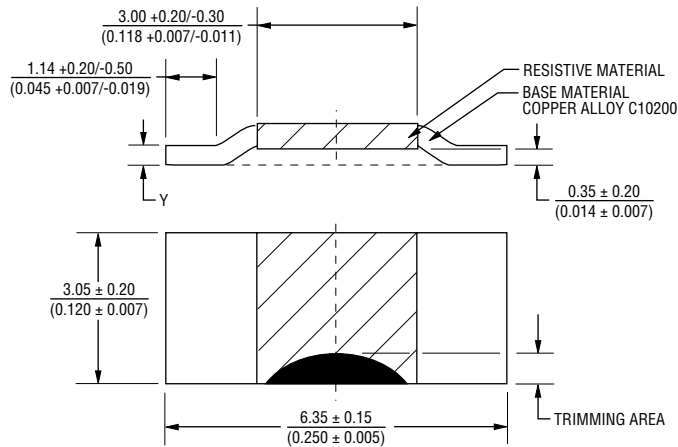

Part Number	Dimension Y
CSS2H-2512R-L500x	$\frac{0.84 \pm 0.1}{(0.033 \pm 0.004)}$
CSS2H-2512R-1L00x	$\frac{0.42 \pm 0.1}{(0.016 \pm 0.004)}$
CSS2H-2512K-2L00x	
CSS2H-2512K-3L00x	

DIMENSIONS:  $\frac{\text{MM}}{(\text{INCHES})}$

\*RoHS Directive 2002/95/EC Jan. 27, 2003 including annex and RoHS Recast 2011/65/EU June 8, 2011.

Specifications are subject to change without notice.

The device characteristics and parameters in this data sheet can and do vary in different applications and actual device performance may vary over time. Users should verify actual device performance in their specific applications.

# Model CSS2H-2512 Series Current Sense Resistor

**BOURNS®**

## Recommended Pad Layout

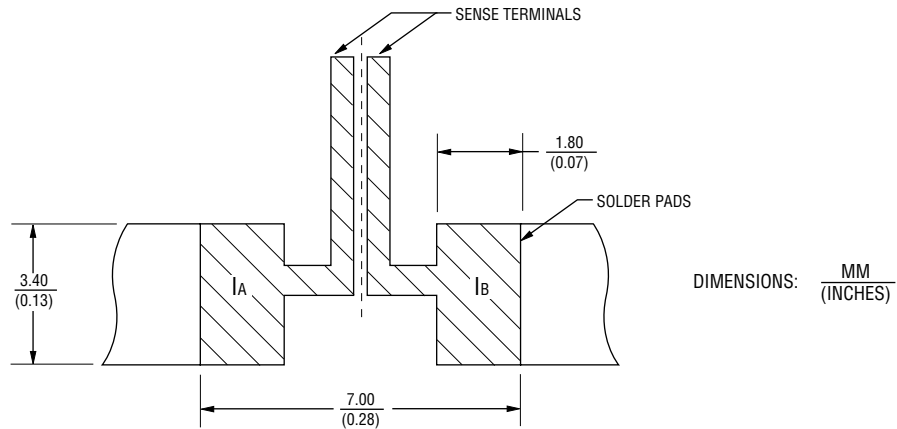

## Power Derating Curves

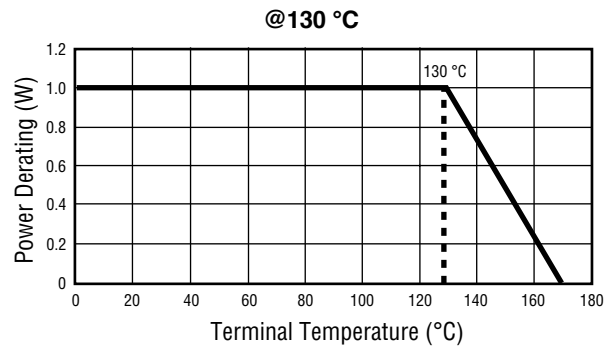
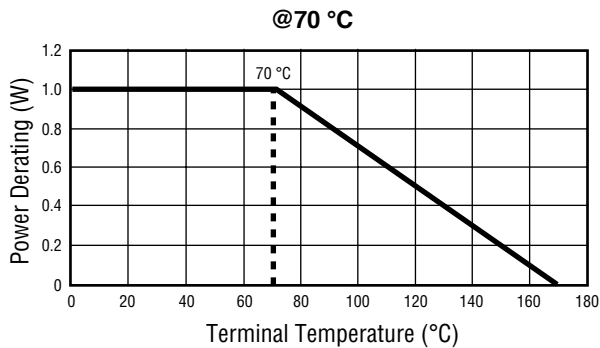

## Packaging Specifications

Components packaged per EIA-481.  
 Reel Size: 13 inches  
 Tape Width: 12 mm  
 Quantity: 3,000 pcs. per Reel

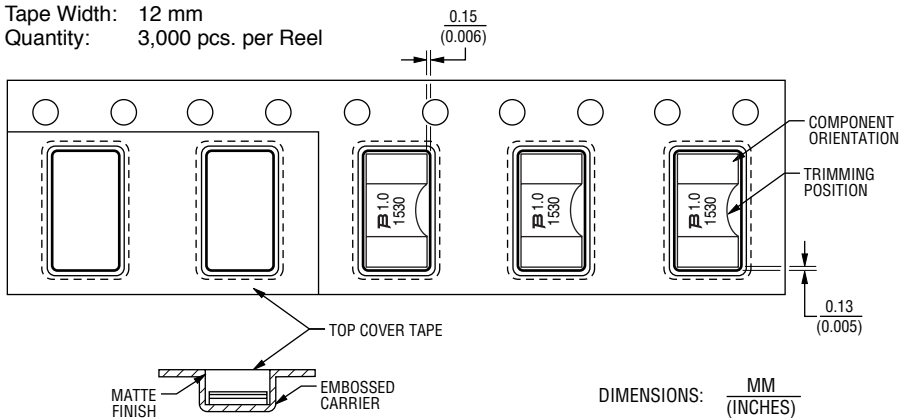

**BOURNS®**

**Asia-Pacific:**  
 Tel: +886-2 2562-4117  
 Email: asiacus@bourns.com

**Europe:**  
 Tel: +36 88 520 390  
 Email: eurocus@bourns.com

**The Americas:**  
 Tel: +1-951 781-5500  
 Email: americus@bourns.com  
[www.bourns.com](http://www.bourns.com)