

System Motor Driver Series for CD·DVD·BD Players

3ch System Motor Driver

For Car Audio

BD8271EFV

General Description

BD8271EFV is 3ch power driver developed for driving stepper motor and DC motor (or actuator coil). Blu-ray's motor & coil can be driven, when used along with 6ch DVD power driver.

Features

- Each driver of SLED (2ch) and Actuator (1ch) are installed in a single-chip.
- ON/OFF and the standby mode of 3ch can be selected using two control terminals.
- Built-in triangular wave generator circuit.
- Adopts HTSSOP-B24 package that has high power dissipation.
- Built-in thermal shutdown function.
- Highly effective SLED driver with PWM drive system.
- Built-in 2ch SLED driver that corresponds to the stepper motor drive.
- The actuator driver is linear BTL type.

Applications

Car Audio

Key Specifications

■ Power Supply Voltage	4.5V to 14V
■ Operating Temperature Range	-40°C to +85°C
■ Output On Resistance (SLED)	2.2 Ω (Typ)
■ Output Saturation Voltage (Actuator)	0.9 V (Typ)

Package

HTSSOP-B24

W(Typ) D(Typ) H(Max)
7.80mm x 7.60mm x 1.00mm



Typical Application Circuit

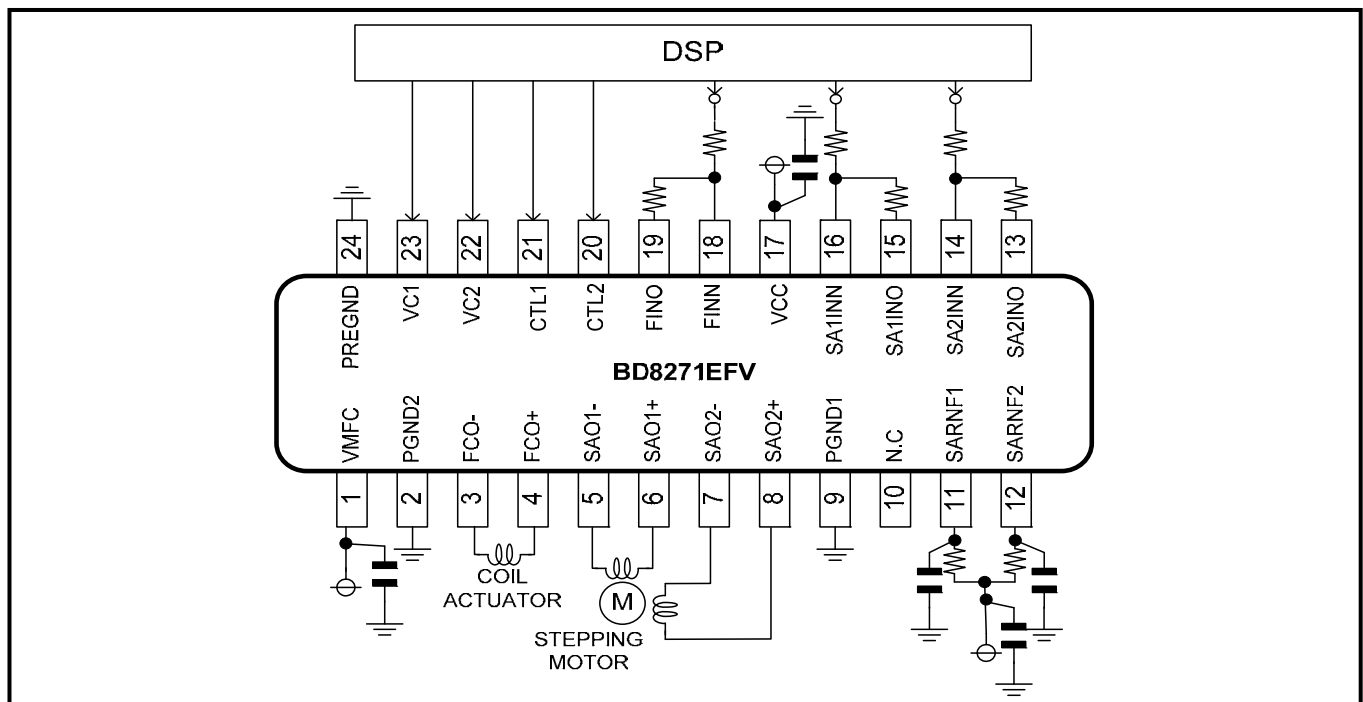

Figure 1. Application Circuit

Pin Configuration

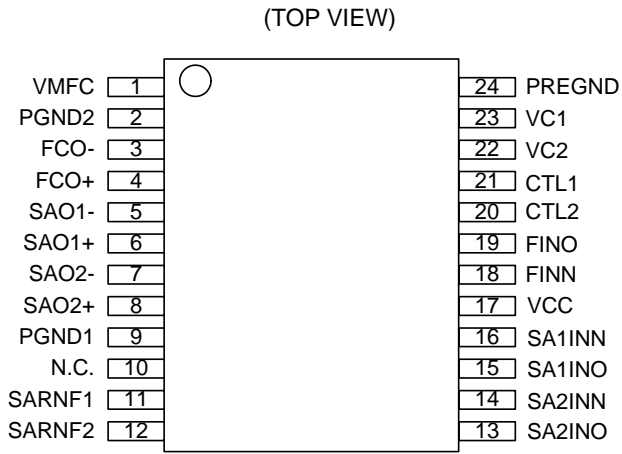

Figure 2. Pin Configuration

Pin Description

Pin No.	Symbol	Function
1	VMFC	Power supply for BTL
2	PGND2	Power ground 2
3	FCO-	Focus driver negative output
4	FCO+	Focus driver positive output
5	SAO1-	Stepper driver 1 negative output
6	SAO1+	Stepper driver 1 positive output
7	SAO2-	Stepper driver 2 negative output
8	SAO2+	Stepper driver 2 positive output
9	PGND1	Power ground 1
10	N.C.	-
11	SARNF1	Stepper driver 1 current detection
12	SARNF2	Stepper driver 2 current detection
13	SA2INO	Output for stepper driver 2 pre-opamp
14	SA2INN	Inverting input for stepper driver 2 pre-opamp
15	SA1INO	Output for stepper driver 1 pre-opamp
16	SA1INN	Inverting input for stepper driver 1 pre-opamp
17	VCC	Pre-block power supply
18	FINN	Inverting input for focus driver pre-opamp
19	FINO	Output for focus driver pre-opamp
20	CTL2	Driver logic control input 2
21	CTL1	Driver logic control input 1
22	VC2	Control standard voltage input 2
23	VC1	Control standard voltage input 1
24	PREGND	Pre-block ground

Block Diagram

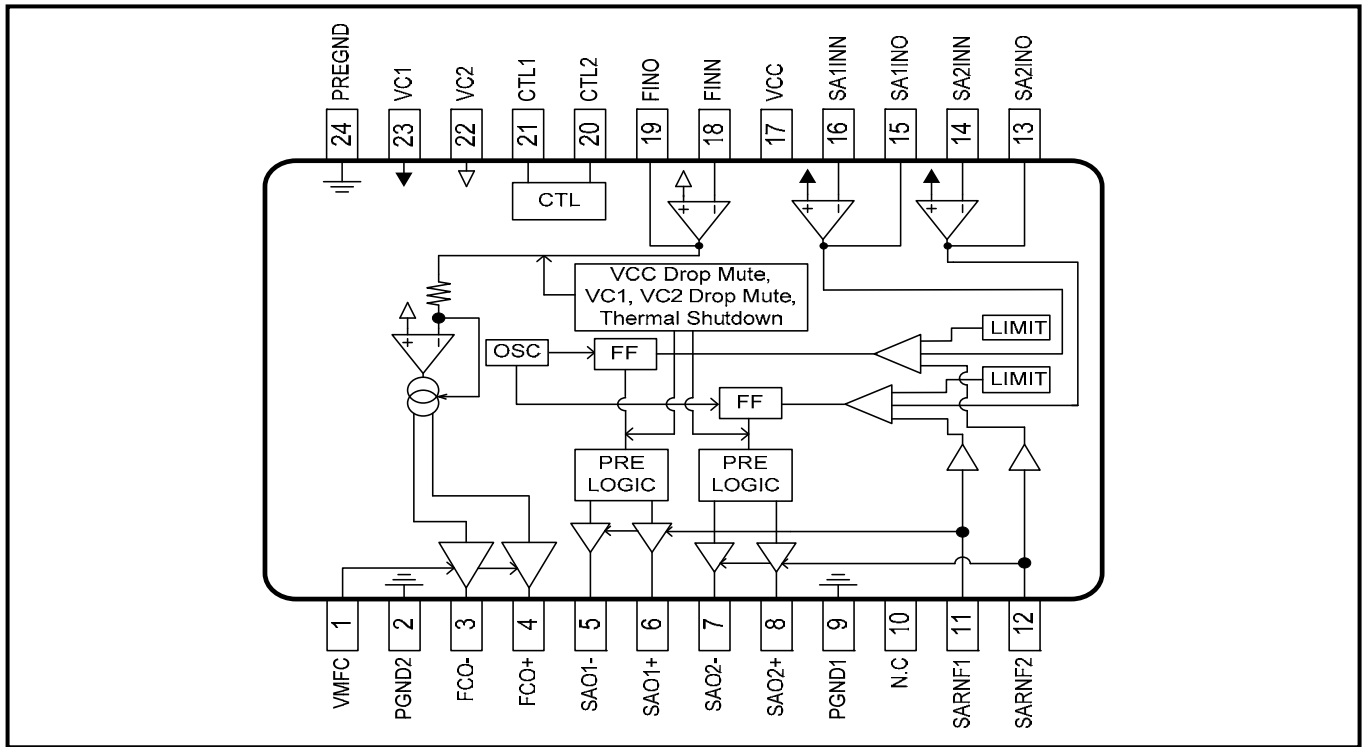

Figure 3. Block Diagram

Absolute Maximum Ratings (Ta=25°C)

Parameter	Symbol	Rating	Unit
MOS Output Power Supply Voltage	V_{SAVM}, V_{SARNF}	15 ^(Note 1)	V
BTL Output Power Supply Voltage	V_{VMFC}	15	V
Pre-Block Power Supply Voltage	V_{VCC}	15	V
Input Terminal Voltage 1	V_{in1} ^(Note 2)	V_{VCC}	V
Input Terminal Voltage 2	V_{in2} ^(Note 3)	V_{SAVM}	V
Power Dissipation	Pd	1.1 ^(Note 4)	W
		4.0 ^(Note 5)	
Operating Temperature Range	Topr	-40 to +85	°C
Storage Temperature	Tstg	-55 to +150	°C
Junction Temperature	Tjmax	+150	°C

(Note 1) Power MOS output terminals are contained.

(Note 2) Vin1 supplies the following terminals: CTL1, CTL2, Vc1, Vc2, FINN

(Note 3) Vin2 supplies the following terminals: SA1INN, SA2INN

(Note 4) Rated for 70mm×70mm×1.6mm, one layer substrate (back copper foil 0mm×0mm), Derated by 8.8mW/°C when operating above Ta=25°C.

(Note 5) Rated for 70mm×70mm×1.6mm, four layer substrate (back copper foil 70mm×70mm), Derated by 32.0mW/°C when operating above Ta=25°C.

Caution: Operating the IC over the absolute maximum ratings may damage the IC. The damage can either be a short circuit between pins or an open circuit between pins and the internal circuitry. Therefore, it is important to consider circuit protection measures, such as adding a fuse, in case the IC is operated over the absolute maximum ratings.

Recommended Operating Conditions (Ta=-40°C to +85°C)

Parameter	Symbol	Min	Typ	Max	Unit
Pre-Block Power Supply Voltage ^(Note 1)	V_{VCC}	4.5	8.0	14	V
Actuator Driver Power Supply Voltage ^(Note 1)	V_{VMFC}	4.5	8.0	V_{VCC}	V
SLED Driver Power Supply Voltage ^(Note 1)	V_{SARNF}	4.5	8.0	V_{VCC}	V

(Note 1) Consider power consumption when deciding power supply voltage.

Electrical Characteristics(Unless otherwise noted, $T_a=25^{\circ}\text{C}$, $V_{\text{VCC}}=V_{\text{SAVM}}=8\text{V}$, $V_{\text{VMFC}}=5\text{V}$, $V_{\text{VC1}}=V_{\text{VC2}}=1.65\text{V}$, $R_{\text{SARNF1}}=R_{\text{SARNF2}}=0.5\Omega$)

Parameter	Symbol	Limit			Unit	Conditions
		Min	Typ	Max		
<Circuit Current>						
Standby Current	I_{ST}	-	0.6	0.9	mA	
Quiescent Current	I_{Q}	-	11.2	17.0	mA	At no load
<SLED Motor Driver>						
Input Dead Zone (one side)	V_{DZSA}	5	15	30	mV	
Input-Output Gain	g_{MSA}	425	500	575	mA/V	
Input Offset Voltage	V_{IOSA}	-5	-	+5	mV	
Input Bias Current	I_{BIASSA}	-300	-50	-10	nA	
Output ON-Resistance (TOTAL)	R_{ONSA}	-	2.2	3.7	Ω	$I_{\text{L}}=500\text{mA}$
Output Limit Current	I_{LIMSA}	672	800	928	mA	
PWM Frequency	f_{OSC}	-	113	-	kHz	
<BTL Driver>						
Output Offset Voltage	V_{OFFT}	-50	0	+50	mV	
Output Saturation Voltage (TOTAL)	V_{OFT}	-	0.9	1.6	V	$I_{\text{L}}=500\text{mA}$
Voltage Gain	G_{VFT}	10.5	12	13.5	dB	
<CTL1, CTL2>						
L Input Voltage	V_{IL}	GND	-	0.8	V	
H Input Voltage	V_{IH}	2	-	VCC	V	
High Level Input Current	I_{CTH}	-	50	100	μA	$V_{\text{CTL1}}, V_{\text{CTL2}}=3.3\text{V}$
<Pre-opamp>						
Input Offset Voltage	V_{IOACT}	-5	0	+5	mV	
Input Bias Current	I_{BIASACT}	-300	-50	-10	nA	
<Function>						
VC1 Drop Mute Voltage	V_{MVC1}	0.4	0.7	1	V	
VC2 Drop Mute Voltage	V_{MVC2}	0.4	0.7	1	V	
VCC Drop Mute Voltage	V_{MVCC}	3.4	3.8	4.2	V	
VC1 Input Current	I_{VC1}	-	4	8	μA	
VC2 Input Current	I_{VC2}	-	4	8	μA	

Application Information

1. Driver Control (CTL1, CTL2, VC1, VC2)

All driver output conditions are controlled by switching the CTL1 and CTL2 terminals to High and Low levels. The table below shows the logic.

(1) High and Low levels

Terminal	Pin No	L	H
CTL1	Pin21	Less than 0.8V	More than 2V
CTL2	Pin20		
VC1	Pin23	Less than 0.4V	More than 1V
VC2	Pin22		

(2) Driver output conditions

CTL1 [Pin21]	CTL2 [Pin20]	SLED ^(Note 1)	BTL
L	L	STBY	STBY
L	H	SB	ACTIVE
H	L	ACTIVE	MUTE
H	H	ACTIVE	ACTIVE

(Note 1) Refer to the table No.(3).

(a) At VC1=L, stepper outputs become MUTE (VC1 Drop MUTE).

(b) At VC2=L, BTL outputs become MUTE (VC2 Drop MUTE).

(c) At STBY, pre-opamp, internal amplifier, and all outputs are OFF. Outputs become Hi-Z.

At MUTE, all outputs are OFF. Outputs become Hi-Z.

(d) The states of each terminal at STBY and MUTE

At STBY, input terminals (Pin13, 14, 15, 16, 18, 19) become Hi-Z and can not accept any input.

In this case, each VC1 and VC2 terminal (Pin23, 22) is pulled-down to GND with an internal resistance of 360kΩ (Typ).

At MUTE, BTL outputs are pulled-up to the voltage of VMFC/2 by an internal resistance of 20kΩ (Typ).

At VCC Drop MUTE, VC1, 2 Drop MUTE and Thermal Shut Down, outputs become Hi-Z same as MUTE.

(3) Mode table for SLED

Mode	Operation
Active	Normal operation
SB	Compulsion short brake ^(Note 2)

(Note 2) In this mode, both outputs (positive and negative) of SLED driver become Low regardless of SAIN input.

2. Torque Command for SLED Driver

The relation between the torque command input and the output current detection terminals input is expressed as shown below:

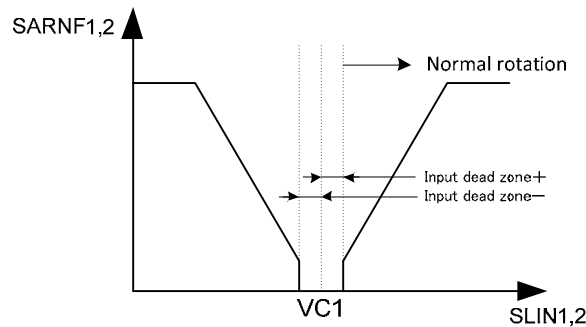

Figure 4. SLED Input vs Output Current

The input-output gain (gm_{SA}) and the output limit current (I_{LIMSA}) depend on the resistance of $R_{SARNF1,2}$ (output current detection resistor). Refer to the formula in the table below.

The gain for SLED driver can be adjusted by pre-opamp resistors.

The table below shows the output terminal conditions for SLED driver during dead zone and current limit detection:

(1) State of Output Terminals

	SLED
Input Dead Zone	Short brake
When Limit Operates	Short brake

(2) Gain Formula (Typ)

	SLED
Input-Output Gain	$gm_{SA} = 0.25 / R_{SARNF1,2}$ (A/V)
Output Limit Current	$I_{LIMSA} = 0.4 / R_{SARNF1,2}$ (A)
Input-Output Gain with Resistor Connected	$gm_{SA} \times R2/R1$ (A/V) (R2/R1 is pre-opamp gain)

3. PWM Oscillation Frequency (SLED)

The PWM oscillation for SLED driver is continuous. The oscillating frequency is 113kHz (Typ).

4. VCC Drop Mute

If VCC terminal voltage becomes 3.8V (Typ) or less, all output channels turn OFF.

5. Thermal Shutdown Circuit (TSD)

Thermal shutdown circuit is designed to turn off all output channels when the junction temperature (T_j) reaches 175°C (Typ) (with 25°C (Typ) hysteresis).

Noise Suppression

The following are possible causes of noise of the PWM driver.

- A. Noise from Power Line or Ground
- B. Radiated Noise

1. Countermeasures against A

- (1) Reduce wiring impedance on 8V system power supply (SARNF1, SARNF2, VCC), 5V system power supply (VMFC) and power GND (PGND1, PGND2) lines where high current flows. Make sure that they are separated from power supply lines of the other devices so that they do not have common impedance. (Figure 5.)

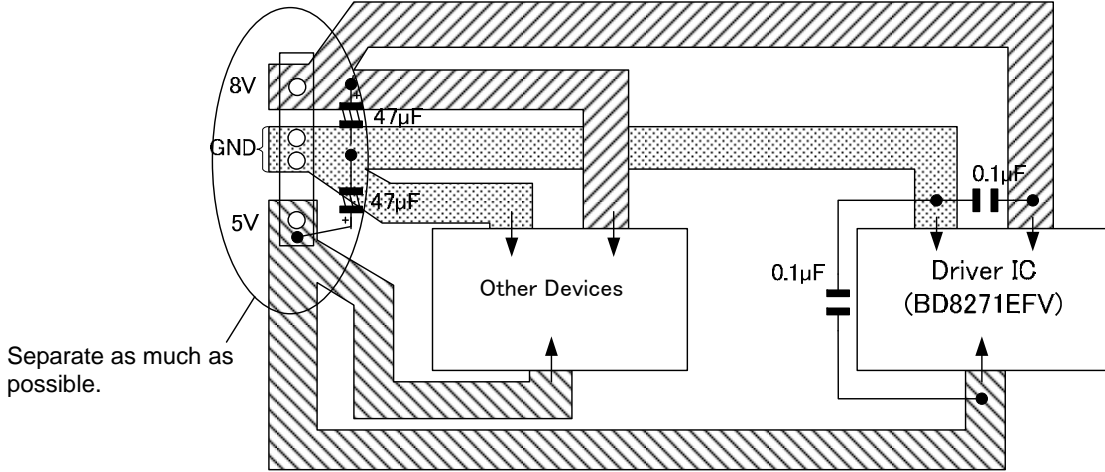

Figure 5. Pattern Example

- (2) Provide a low ESR electrolytic capacitor between the power terminal and the ground terminal of the driver to achieve strong stabilization. Provide a ceramic capacitor with good high frequency property next to the IC. Also provide a ceramic capacitor with good high frequency property between SARNF1, 2 and PGND1. (Figure 6.) This can reduce power supply ripple due to PWM switching.

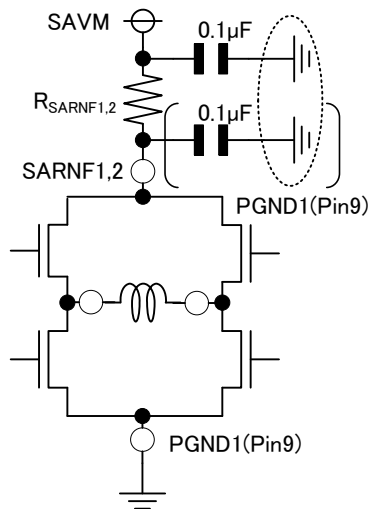

Figure 6. Position of Ceramic Capacitors

(a) Power Supply System *number in circles is the pin number.

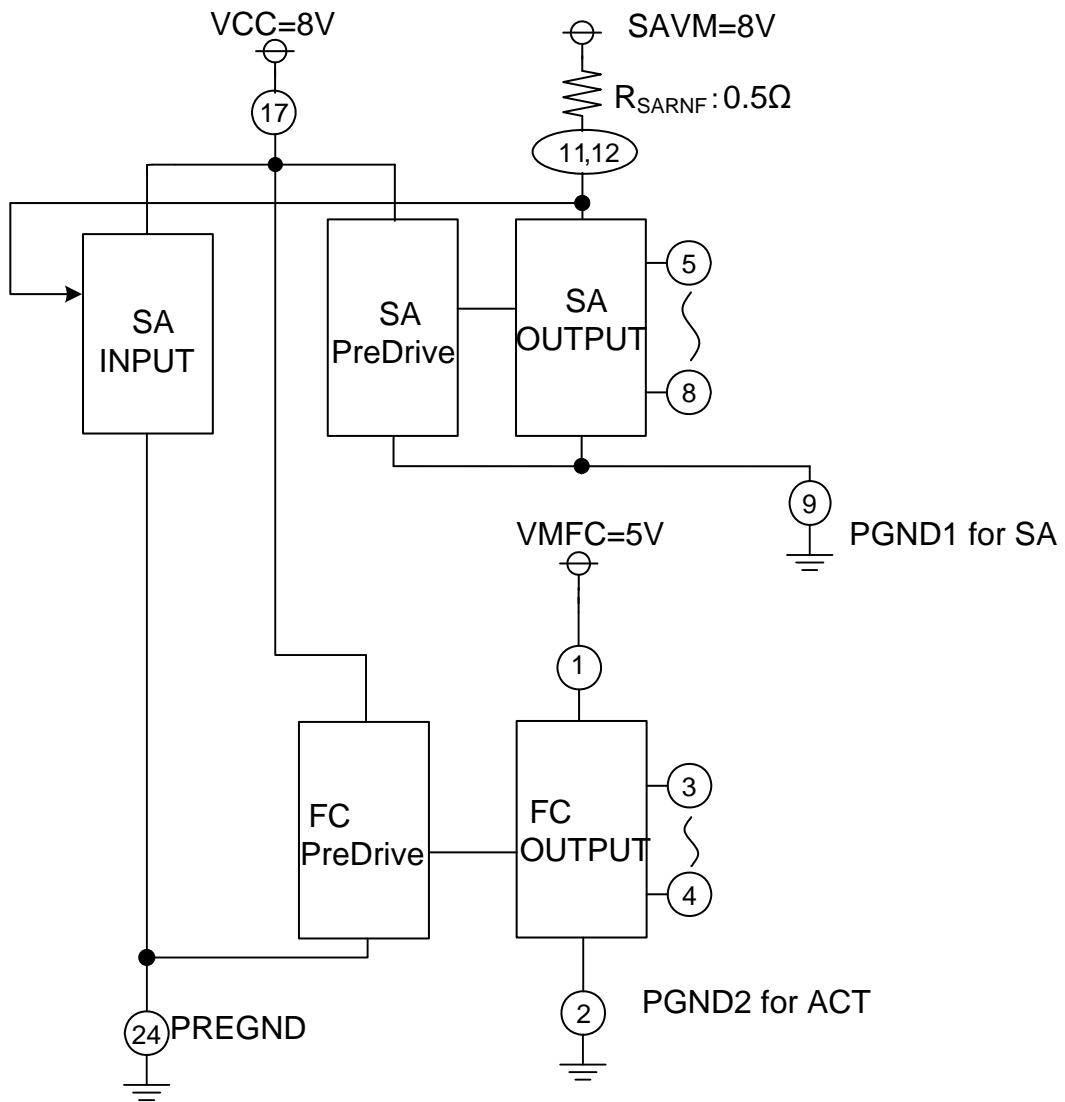

Figure 7. Power Supply and Ground Connection of Internal Block

(3) If there's no improvement with the condition (1) and (2), there are two improvement way. The first way is to insert an LC filter in the power line or in the ground line. (Figure 8.)

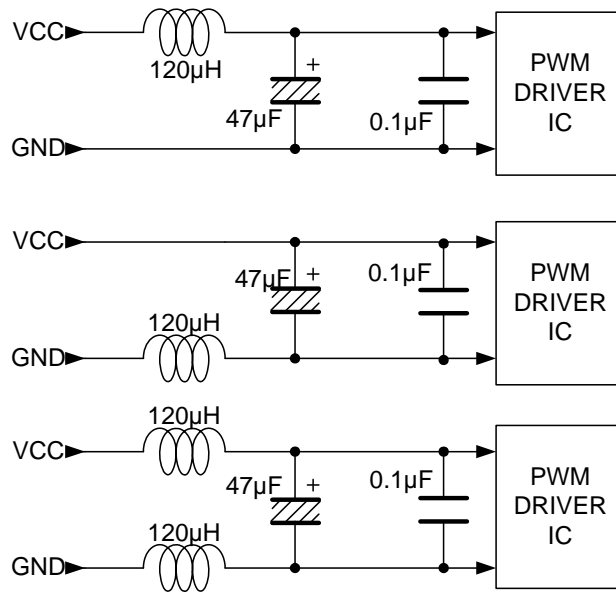

Figure 8. Example of LC filter

(4) The second way is to add a capacitor of around 2200 pF between each output and the ground. In this case, ensure that the GND wiring should not have any common impedance with other signals. (Figure 9.)

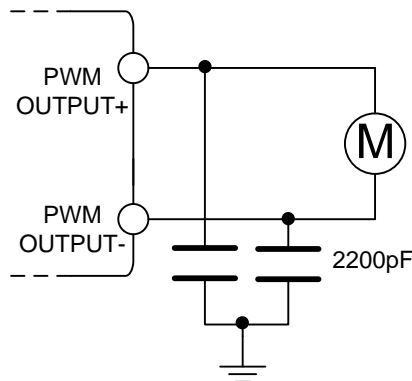

Figure 9. Snubber Circuit

2. Countermeasures against B (Refer to Figure 10)

- (1) Ensure certain distance between RF signal line and PWM-drive output line. If it's not possible to provide space between these lines, shield the RF signal line with a stable GND except for power GND.
- (2) Same as (1), flexible cable for pickup should be shielded with GND in order to separate noise between the signal line and the actuator drive output line.
- (3) Separate the flexible cable for the motor and for the pickup.

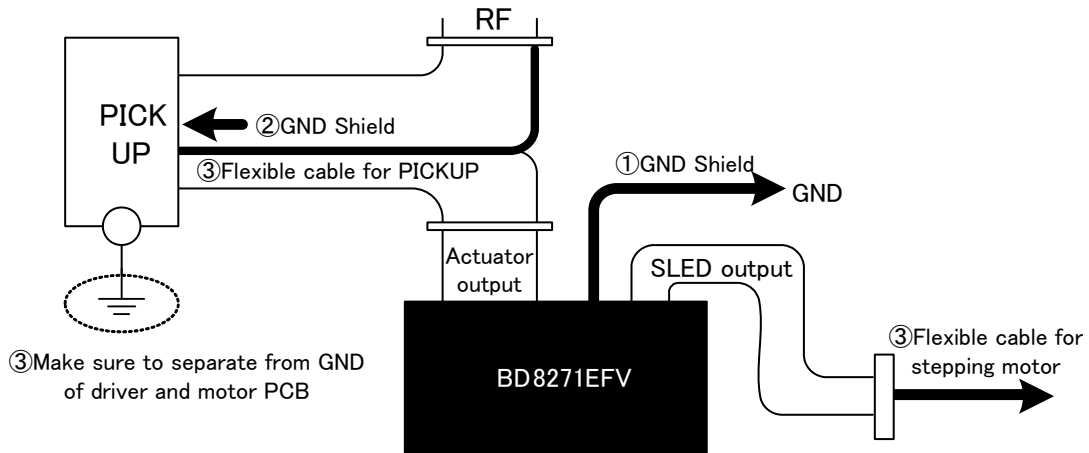

Figure 10. Countermeasure for RF Noise

Gain calculation

1. Actuator (with pre-opamp)

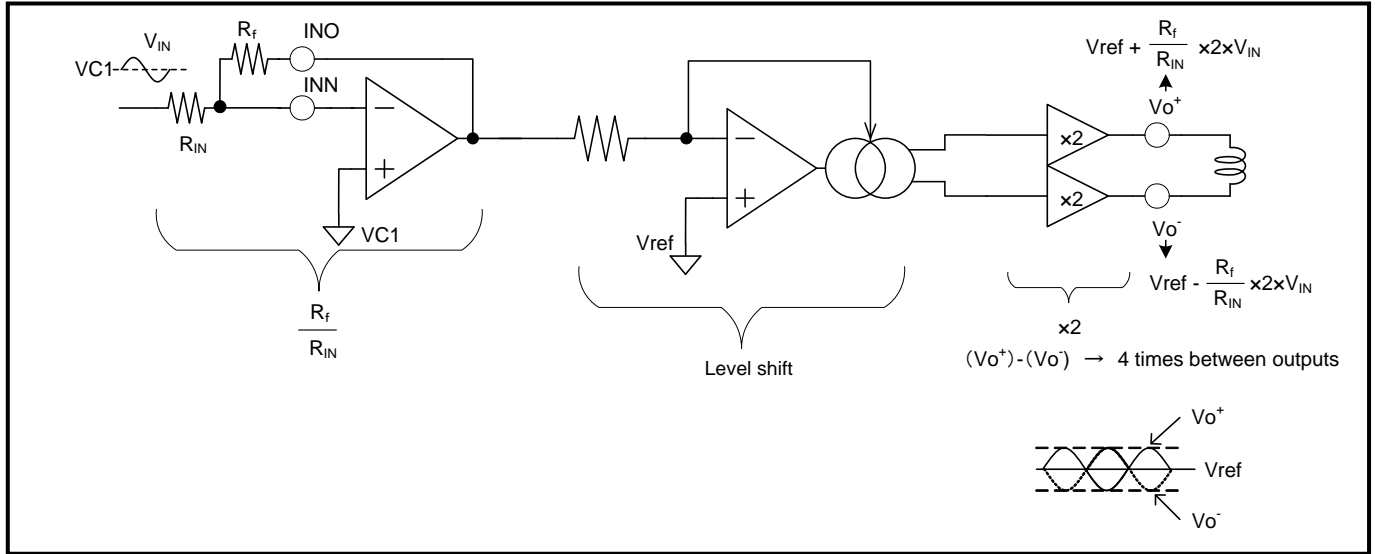

Figure 11. Gain Calculation for Actuator

$$\text{Gain} = \frac{V_O}{V_{IN}} = \frac{R_f}{R_{IN}} \times 2 \times 2$$

$$R_{IN} = R_f (\text{ex. } 10\text{k}\Omega)$$

$$\text{Gain} = \frac{10\text{k}\Omega}{10\text{k}\Omega} \times 2 \times 2 = 12\text{dB}$$

2. SLED (with pre-opamp)

$$\frac{I_{\text{opeak}}}{V_{IN}} = \frac{0.25}{R_{SARNF}}$$

$$I_O = \frac{V_O}{R_L} \quad \frac{V_{\text{opeak}}}{V_{IN}} = \frac{0.25}{R_{SARNF}} \times R_L$$

At input resistor R_{IN} connect

$$\frac{I_{\text{opeak}}}{V_{IN}} = \frac{R_f}{R_{IN}} \times \frac{0.25}{R_{SARNF}} \text{ [A/V]}$$

$$\frac{V_{\text{opeak}}}{V_{IN}} = \frac{R_f}{R_{IN}} \times \frac{0.25}{R_{SARNF}} \times R_L \text{ [V/V]}$$

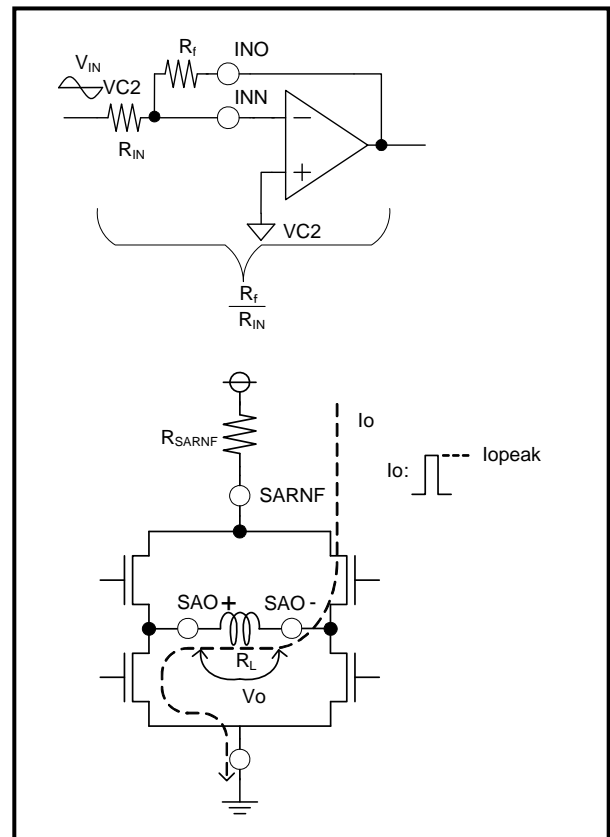

Figure 12. Gain Calculation for SLED

Typical Application Circuit

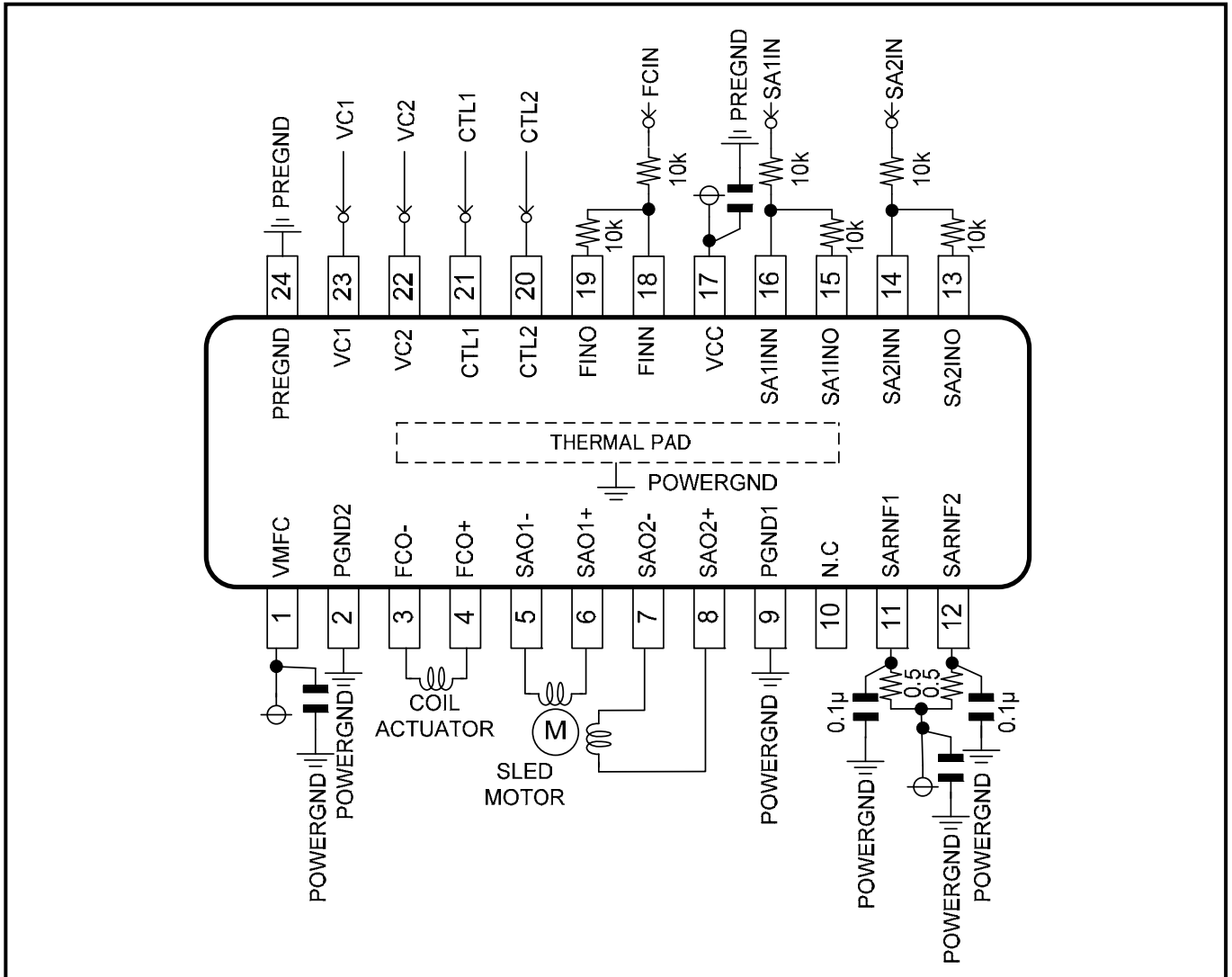

Figure 13. Typical Application Circuit

Power Dissipation

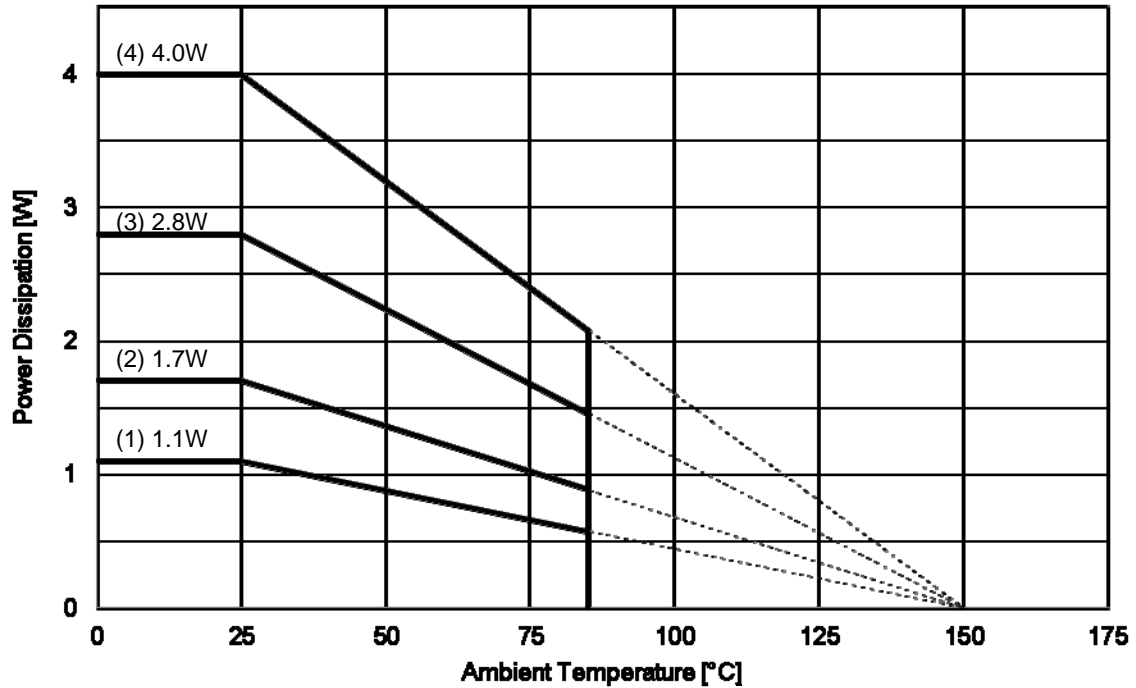

Figure 14. Power Dissipation

Board size : 70mm×70mm×1.6mm

The board and the thermal plate of the IC are connected with solder.

Board (1): 1 layer board (copper foil 0mm × 0mm)

Board (2): 2 layer board (copper foil 15mm × 15mm)

Board (3): 2 layer board (copper foil 70mm × 70mm)

Board (4): 4 layer board (copper foil 70mm × 70mm)

Board (1) : $\theta_{ja} = 113.6 \text{ }^\circ\text{C/W}$

Board (2) : $\theta_{ja} = 73.5 \text{ }^\circ\text{C/W}$

Board (3) : $\theta_{ja} = 44.6 \text{ }^\circ\text{C/W}$

Board (4) : $\theta_{ja} = 31.3 \text{ }^\circ\text{C/W}$

For $T_a=85^\circ\text{C}$:

Board (1) : $P_d = 0.57\text{W}$

Board (2) : $P_d = 0.88\text{W}$

Board (3) : $P_d = 1.46\text{W}$

Board (4) : $P_d = 2.08\text{W}$

CAUTION: P_d depends on the number of the PCB layers and area. P_d values are determined through measurement.

Terminal Equivalent Circuit (with typical resistance and capacitance values)

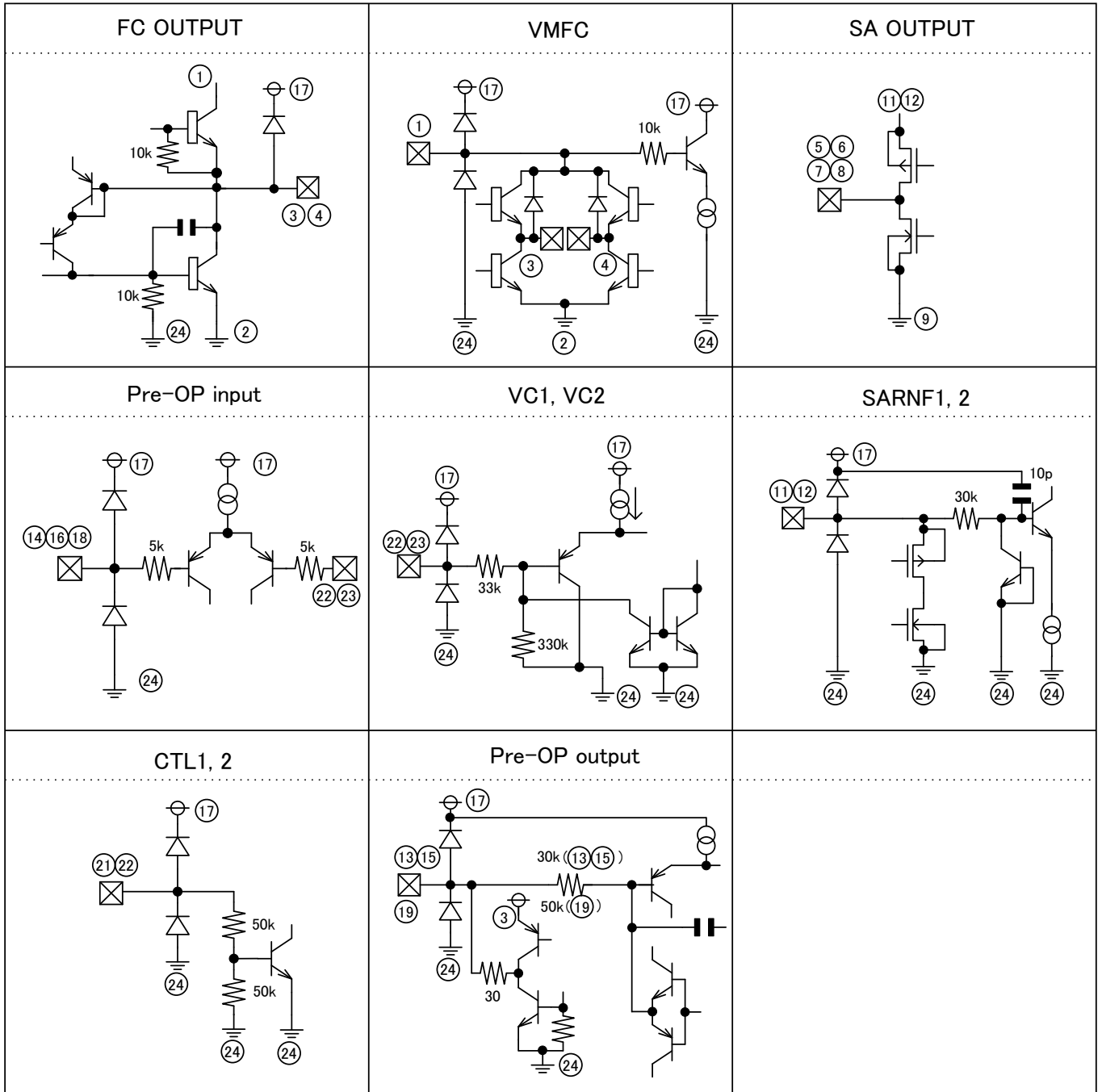

Application Board Schematic

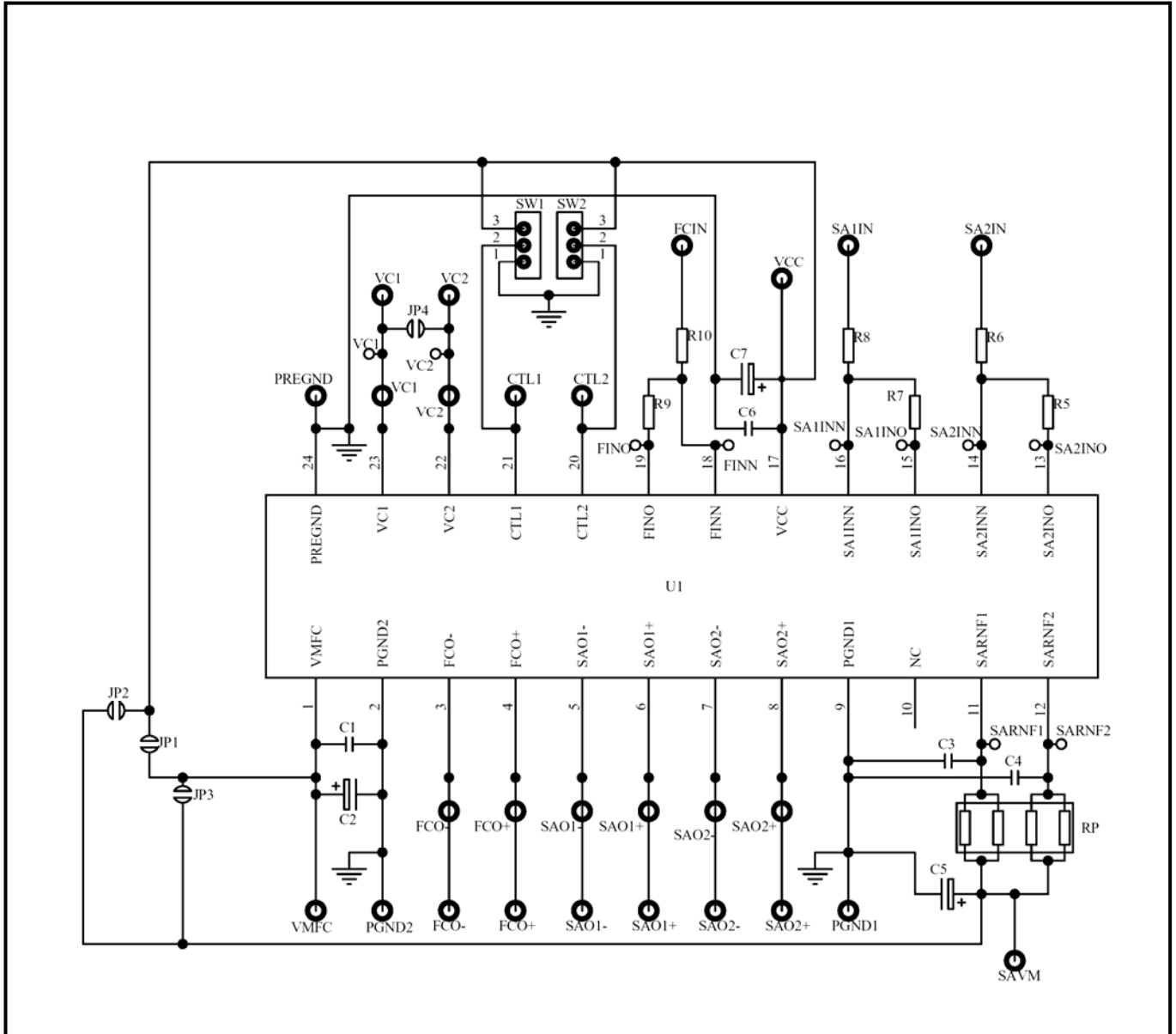

Figure 15. PCB schematic

Application Board Pattern

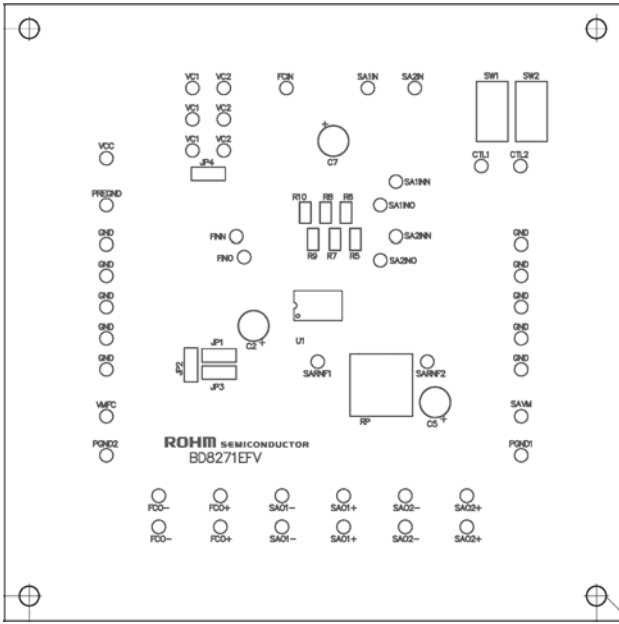

Figure 16. Top Silkscreen Overlay

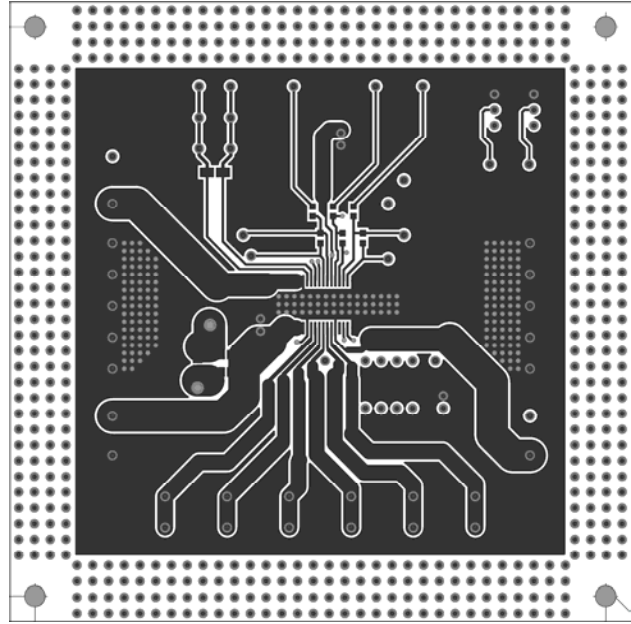

Figure 17. Top Layer

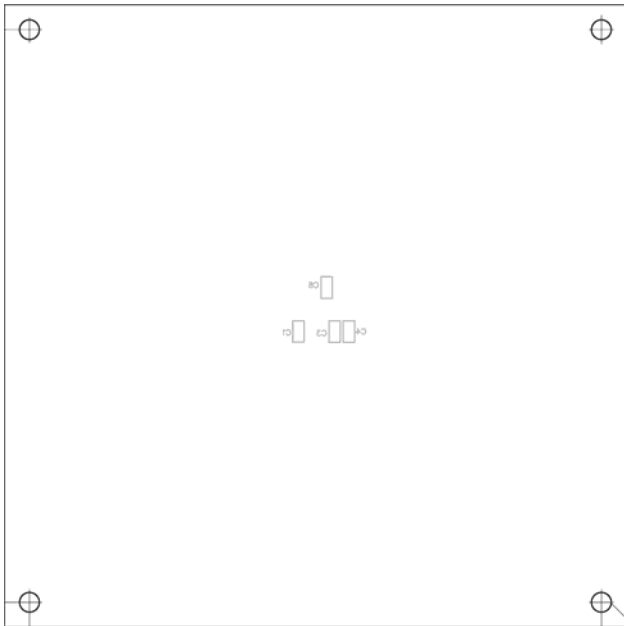

Figure 18. Bottom Silkscreen Overlay

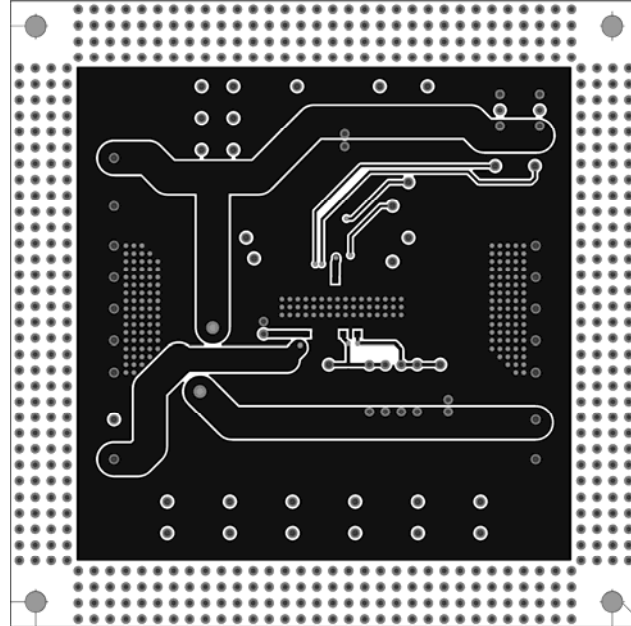

Figure 19. Bottom Layer

ASO (Area of Safe Operation) Data (Reference Data)

BTL driver output (Pin3, 4)
 VCC=SAVM=VMFC=15V
 VC1=VC2=3V
 Ta=25°C
 TON=0.1sec

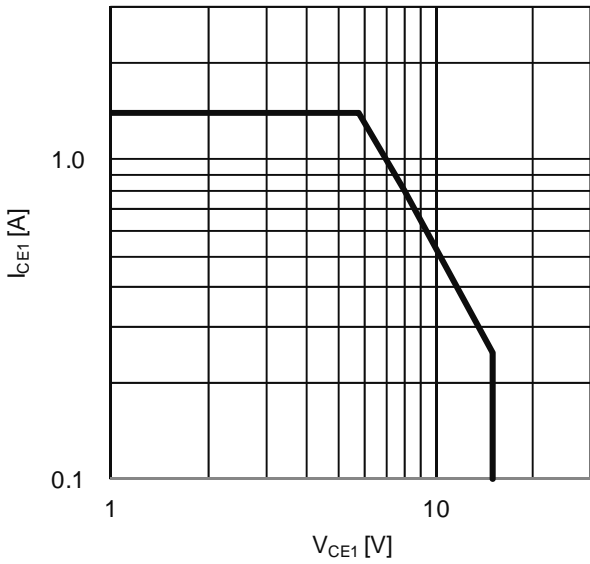
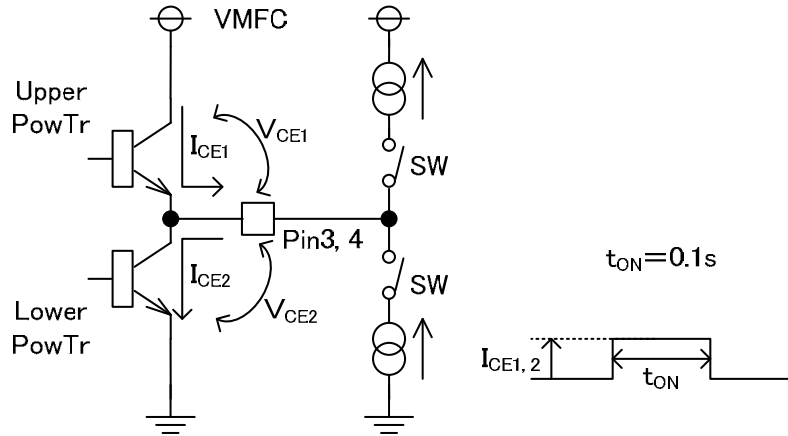

Figure 20. Upper PowTr ASO

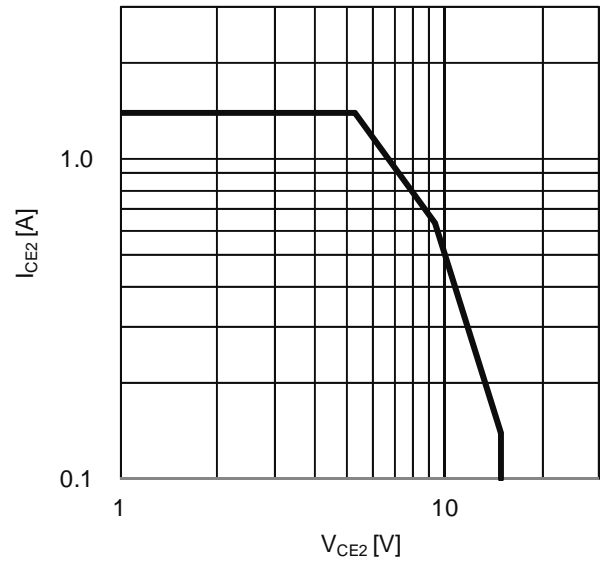

Figure 21. Lower PowTr ASO

Operational Notes

- 1. Reverse Connection of Power Supply**

Connecting the power supply in reverse polarity can damage the IC. Take precautions against reverse polarity when connecting the power supply, such as mounting an external diode between the power supply and the IC's power supply pins.
- 2. Power Supply Lines**

Design the PCB layout pattern to provide low impedance supply lines. Separate the ground and supply lines of the digital and analog blocks to prevent noise in the ground and supply lines of the digital block from affecting the analog block. Furthermore, connect a capacitor to ground at all power supply pins. Consider the effect of temperature and aging on the capacitance value when using electrolytic capacitors.
- 3. Ground Voltage**

Ensure that no pins are at a voltage below that of the ground pin at any time, even during transient condition. However, pins that drive inductive loads (e.g. motor driver outputs, DC-DC converter outputs) may inevitably go below ground due to back EMF or electromotive force. In such cases, the user should make sure that such voltages going below ground will not cause the IC and the system to malfunction by examining carefully all relevant factors and conditions such as motor characteristics, supply voltage, operating frequency and PCB wiring to name a few.
- 4. Ground Wiring Pattern**

When using both small-signal and large-current ground traces, the two ground traces should be routed separately but connected to a single ground at the reference point of the application board to avoid fluctuations in the small-signal ground caused by large currents. Also ensure that the ground traces of external components do not cause variations on the ground voltage. The ground lines must be as short and thick as possible to reduce line impedance.
- 5. Thermal Consideration**

Should by any chance the power dissipation rating be exceeded the rise in temperature of the chip may result in deterioration of the properties of the chip. The absolute maximum rating of the Pd stated in this specification is when the IC is mounted on a 70mm x 70mm x 1.6mm glass epoxy board. In case of exceeding this absolute maximum rating, increase the board size and copper area to prevent exceeding the Pd rating.
- 6. Recommended Operating Conditions**

These conditions represent a range within which the expected characteristics of the IC can be approximately obtained. The electrical characteristics are guaranteed under the conditions of each parameter.
- 7. Inrush Current**

When power is first supplied to the IC, it is possible that the internal logic may be unstable and inrush current may flow instantaneously due to the internal powering sequence and delays, especially if the IC has more than one power supply. Therefore, give special consideration to power coupling capacitance, power wiring, width of ground wiring, and routing of connections.
- 8. Operation Under Strong Electromagnetic Field**

Operating the IC in the presence of a strong electromagnetic field may cause the IC to malfunction.
- 9. Testing on Application Boards**

When testing the IC on an application board, connecting a capacitor directly to a low-impedance output pin may subject the IC to stress. Always discharge capacitors completely after each process or step. The IC's power supply should always be turned off completely before connecting or removing it from the test setup during the inspection process. To prevent damage from static discharge, ground the IC during assembly and use similar precautions during transport and storage.
- 10. Inter-pin Short and Mounting Errors**

Ensure that the direction and position are correct when mounting the IC on the PCB. Incorrect mounting may result in damaging the IC. Avoid nearby pins being shorted to each other especially to ground, power supply and output pin. Inter-pin shorts could be due to many reasons such as metal particles, water droplets (in very humid environment) and unintentional solder bridge deposited in between pins during assembly to name a few.

Operational Notes – continued

11. Unused Input Pins

Input pins of an IC are often connected to the gate of a MOS transistor. The gate has extremely high impedance and extremely low capacitance. If left unconnected, the electric field from the outside can easily charge it. The small charge acquired in this way is enough to produce a significant effect on the conduction through the transistor and cause unexpected operation of the IC. So unless otherwise specified, unused input pins should be connected to the power supply or ground line.

12. Regarding the Input Pin of the IC

This monolithic IC contains P+ isolation and P substrate layers between adjacent elements in order to keep them isolated. P-N junctions are formed at the intersection of the P layers with the N layers of other elements, creating a parasitic diode or transistor. For example (refer to figure below):

When $GND > Pin A$ and $GND > Pin B$, the P-N junction operates as a parasitic diode.
When $GND > Pin B$, the P-N junction operates as a parasitic transistor.

Parasitic diodes inevitably occur in the structure of the IC. The operation of parasitic diodes can result in mutual interference among circuits, operational faults, or physical damage. Therefore, conditions that cause these diodes to operate, such as applying a voltage lower than the GND voltage to an input pin (and thus to the P substrate) should be avoided.

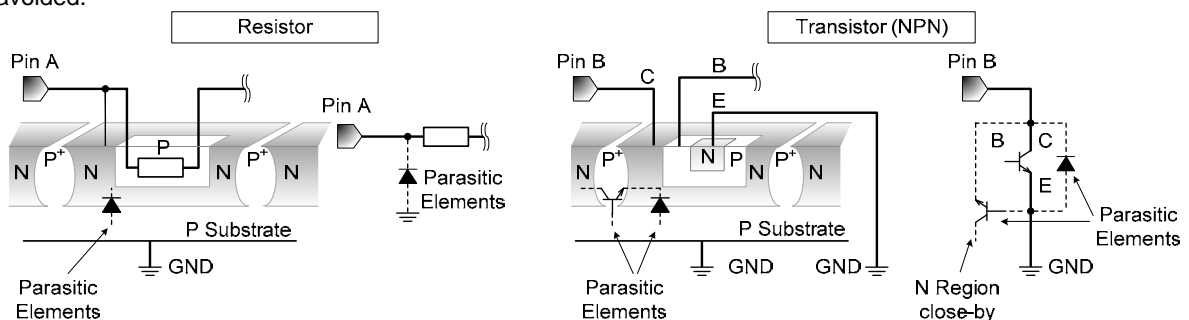

Figure 22. Example of monolithic IC structure

13. Ceramic Capacitor

When using a ceramic capacitor, determine the dielectric constant considering the change of capacitance with temperature and the decrease in nominal capacitance due to DC bias and others.

14. Area of Safe Operation (ASO)

Operate the IC such that the output voltage, output current, and power dissipation are all within the Area of Safe Operation (ASO).

15. Thermal Shutdown Circuit(TSD)

This IC has a built-in thermal shutdown circuit that prevents heat damage to the IC. Normal operation should always be within the IC's power dissipation rating. If however the rating is exceeded for a continued period, the junction temperature (T_j) will rise which will activate the TSD circuit that will turn OFF all output pins. When the T_j falls below the TSD threshold, the circuits are automatically restored to normal operation.

Note that the TSD circuit operates in a situation that exceeds the absolute maximum ratings and therefore, under no circumstances, should the TSD circuit be used in a set design or for any purpose other than protecting the IC from heat damage.

Ordering Information

B D 8 2 7 1 E F V

-

E 2

Product name

Package
EFV : HTSSOP-B24

Packaging and forming specification
E2: Embossed tape and reel
(HTSSOP-B24)

Marking Diagram

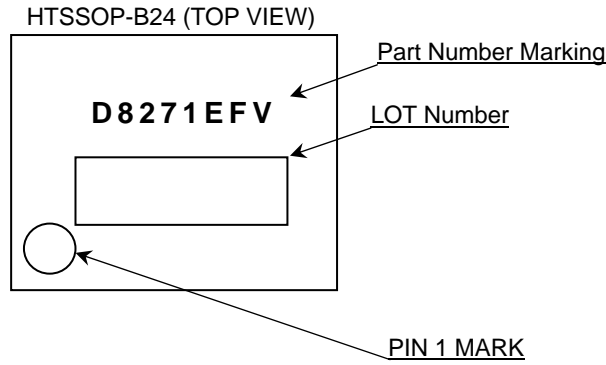

Physical Dimension, Tape and Reel Information

Package Name	HTSSOP-B24
--------------	------------

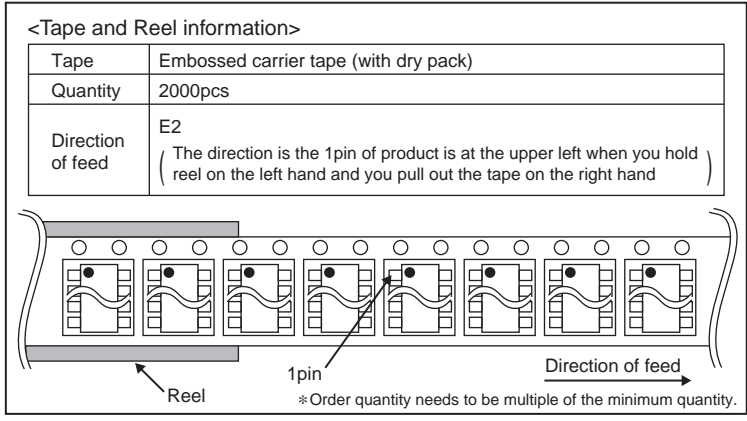
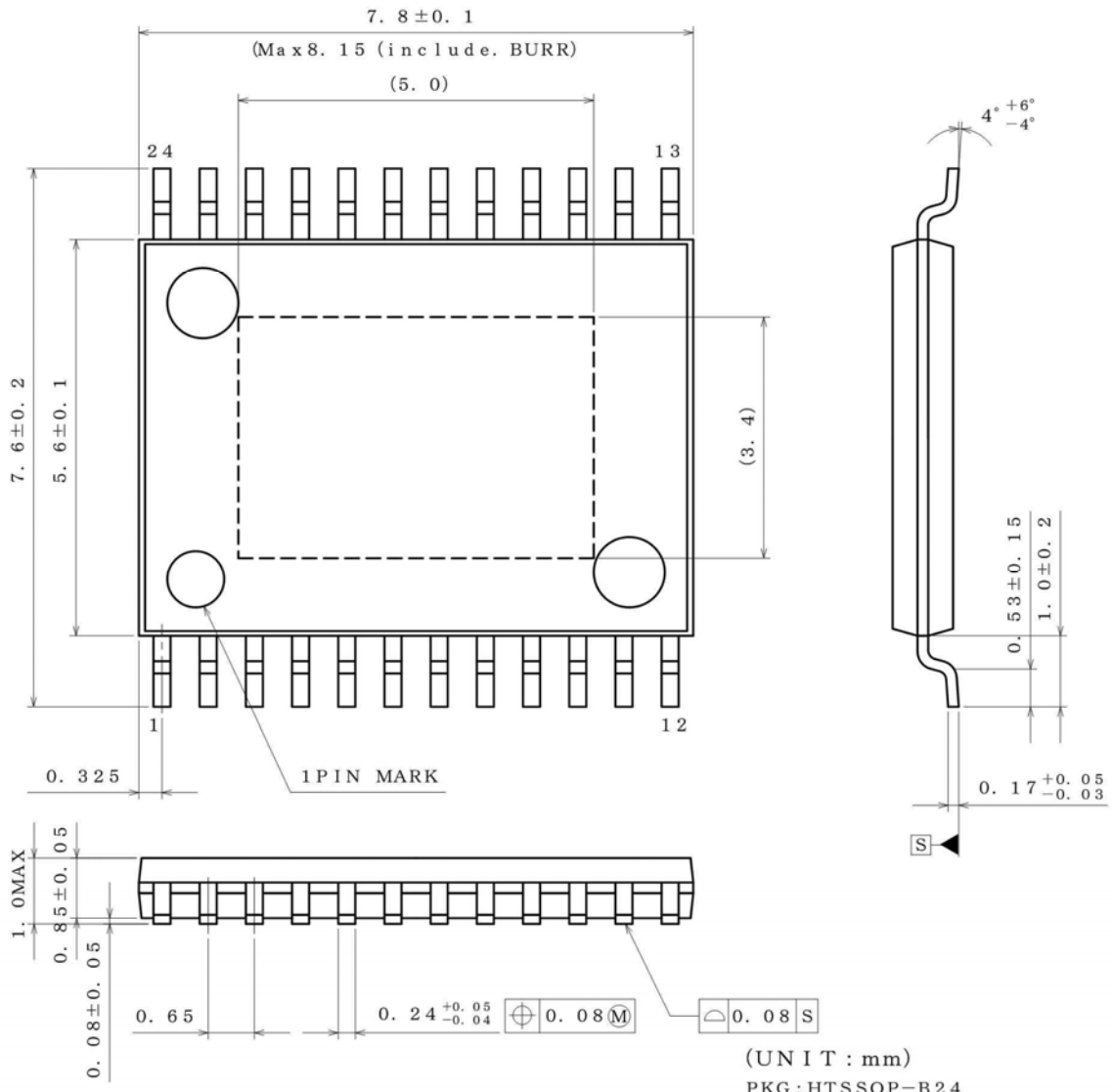

Revision History

Date	Revision	Changes
5.Aug.2013	002	New Release

Notice

Precaution on using ROHM Products

1. If you intend to use our Products in devices requiring extremely high reliability (such as medical equipment ^(Note 1), aircraft/spacecraft, nuclear power controllers, etc.) and whose malfunction or failure may cause loss of human life, bodily injury or serious damage to property ("Specific Applications"), please consult with the ROHM sales representative in advance. Unless otherwise agreed in writing by ROHM in advance, ROHM shall not be in any way responsible or liable for any damages, expenses or losses incurred by you or third parties arising from the use of any ROHM's Products for Specific Applications.

(Note1) Medical Equipment Classification of the Specific Applications

JAPAN	USA	EU	CHINA
CLASS III	CLASS III	CLASS II b	CLASS III
CLASS IV		CLASS III	

2. ROHM designs and manufactures its Products subject to strict quality control system. However, semiconductor products can fail or malfunction at a certain rate. Please be sure to implement, at your own responsibilities, adequate safety measures including but not limited to fail-safe design against the physical injury, damage to any property, which a failure or malfunction of our Products may cause. The following are examples of safety measures:
 - [a] Installation of protection circuits or other protective devices to improve system safety
 - [b] Installation of redundant circuits to reduce the impact of single or multiple circuit failure
3. Our Products are not designed under any special or extraordinary environments or conditions, as exemplified below. Accordingly, ROHM shall not be in any way responsible or liable for any damages, expenses or losses arising from the use of any ROHM's Products under any special or extraordinary environments or conditions. If you intend to use our Products under any special or extraordinary environments or conditions (as exemplified below), your independent verification and confirmation of product performance, reliability, etc, prior to use, must be necessary:
 - [a] Use of our Products in any types of liquid, including water, oils, chemicals, and organic solvents
 - [b] Use of our Products outdoors or in places where the Products are exposed to direct sunlight or dust
 - [c] Use of our Products in places where the Products are exposed to sea wind or corrosive gases, including Cl₂, H₂S, NH₃, SO₂, and NO₂
 - [d] Use of our Products in places where the Products are exposed to static electricity or electromagnetic waves
 - [e] Use of our Products in proximity to heat-producing components, plastic cords, or other flammable items
 - [f] Sealing or coating our Products with resin or other coating materials
 - [g] Use of our Products without cleaning residue of flux (even if you use no-clean type fluxes, cleaning residue of flux is recommended); or Washing our Products by using water or water-soluble cleaning agents for cleaning residue after soldering
 - [h] Use of the Products in places subject to dew condensation
4. The Products are not subject to radiation-proof design.
5. Please verify and confirm characteristics of the final or mounted products in using the Products.
6. In particular, if a transient load (a large amount of load applied in a short period of time, such as pulse. is applied, confirmation of performance characteristics after on-board mounting is strongly recommended. Avoid applying power exceeding normal rated power; exceeding the power rating under steady-state loading condition may negatively affect product performance and reliability.
7. De-rate Power Dissipation (Pd) depending on Ambient temperature (Ta). When used in sealed area, confirm the actual ambient temperature.
8. Confirm that operation temperature is within the specified range described in the product specification.
9. ROHM shall not be in any way responsible or liable for failure induced under deviant condition from what is defined in this document.

Precaution for Mounting / Circuit board design

1. When a highly active halogenous (chlorine, bromine, etc.) flux is used, the residue of flux may negatively affect product performance and reliability.
2. In principle, the reflow soldering method must be used; if flow soldering method is preferred, please consult with the ROHM representative in advance.

For details, please refer to ROHM Mounting specification

Precautions Regarding Application Examples and External Circuits

1. If change is made to the constant of an external circuit, please allow a sufficient margin considering variations of the characteristics of the Products and external components, including transient characteristics, as well as static characteristics.
2. You agree that application notes, reference designs, and associated data and information contained in this document are presented only as guidance for Products use. Therefore, in case you use such information, you are solely responsible for it and you must exercise your own independent verification and judgment in the use of such information contained in this document. ROHM shall not be in any way responsible or liable for any damages, expenses or losses incurred by you or third parties arising from the use of such information.

Precaution for Electrostatic

This Product is electrostatic sensitive product, which may be damaged due to electrostatic discharge. Please take proper caution in your manufacturing process and storage so that voltage exceeding the Products maximum rating will not be applied to Products. Please take special care under dry condition (e.g. Grounding of human body / equipment / solder iron, isolation from charged objects, setting of ionizer, friction prevention and temperature / humidity control).

Precaution for Storage / Transportation

1. Product performance and soldered connections may deteriorate if the Products are stored in the places where:
 - [a] the Products are exposed to sea winds or corrosive gases, including Cl₂, H₂S, NH₃, SO₂, and NO₂
 - [b] the temperature or humidity exceeds those recommended by ROHM
 - [c] the Products are exposed to direct sunshine or condensation
 - [d] the Products are exposed to high Electrostatic
2. Even under ROHM recommended storage condition, solderability of products out of recommended storage time period may be degraded. It is strongly recommended to confirm solderability before using Products of which storage time is exceeding the recommended storage time period.
3. Store / transport cartons in the correct direction, which is indicated on a carton with a symbol. Otherwise bent leads may occur due to excessive stress applied when dropping of a carton.
4. Use Products within the specified time after opening a humidity barrier bag. Baking is required before using Products of which storage time is exceeding the recommended storage time period.

Precaution for Product Label

QR code printed on ROHM Products label is for ROHM's internal use only.

Precaution for Disposition

When disposing Products please dispose them properly using an authorized industry waste company.

Precaution for Foreign Exchange and Foreign Trade act

Since our Products might fall under controlled goods prescribed by the applicable foreign exchange and foreign trade act, please consult with ROHM representative in case of export.

Precaution Regarding Intellectual Property Rights

1. All information and data including but not limited to application example contained in this document is for reference only. ROHM does not warrant that foregoing information or data will not infringe any intellectual property rights or any other rights of any third party regarding such information or data. ROHM shall not be in any way responsible or liable for infringement of any intellectual property rights or other damages arising from use of such information or data.:
2. No license, expressly or implied, is granted hereby under any intellectual property rights or other rights of ROHM or any third parties with respect to the information contained in this document.

Other Precaution

1. This document may not be reprinted or reproduced, in whole or in part, without prior written consent of ROHM.
2. The Products may not be disassembled, converted, modified, reproduced or otherwise changed without prior written consent of ROHM.
3. In no event shall you use in any way whatsoever the Products and the related technical information contained in the Products or this document for any military purposes, including but not limited to, the development of mass-destruction weapons.
4. The proper names of companies or products described in this document are trademarks or registered trademarks of ROHM, its affiliated companies or third parties.

General Precaution

1. Before you use our Products, you are requested to carefully read this document and fully understand its contents. ROHM shall not be in any way responsible or liable for failure, malfunction or accident arising from the use of any ROHM's Products against warning, caution or note contained in this document.
2. All information contained in this document is current as of the issuing date and subject to change without any prior notice. Before purchasing or using ROHM's Products, please confirm the latest information with a ROHM sales representative.
3. The information contained in this document is provided on an "as is" basis and ROHM does not warrant that all information contained in this document is accurate and/or error-free. ROHM shall not be in any way responsible or liable for any damages, expenses or losses incurred by you or third parties resulting from inaccuracy or errors of or concerning such information.