

Features and Benefits

- Micropower consumption for battery powered applications
- Latching output
- Operation down to 2.5V
- High sensitivity for direct reed switch replacement applications
- Chopper stabilized amplifier stage

Application Examples

- Solid state switch
- Handheld Wireless Handset Awake Switch
- Lid close sensor for battery powered devices

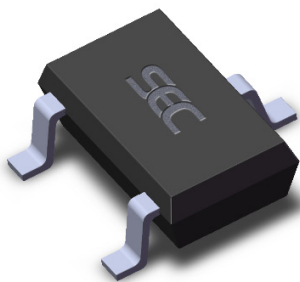

3 pin SOT23 (suffix SO)

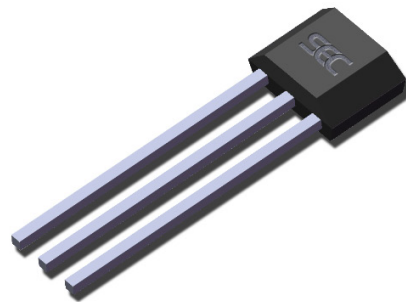

3 pin SIP (suffix UA)

Functional Block Diagram

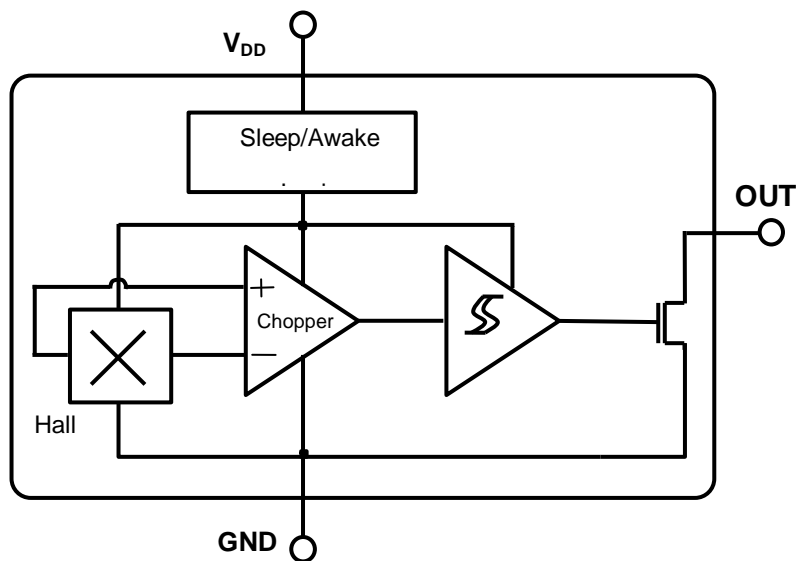

General Description

The SS2412 latching Hall effect sensor IC is fabricated from mixed signal CMOS technology. It incorporates advanced chopper-stabilization techniques to provide accurate and stable magnetic switch points.

The circuit design provides an internally controlled clocking mechanism to cycle power to the Hall element and analog signal processing circuits. This serves to place the high current-consuming portions of the circuit into a “Sleep” mode. Periodically the device is “Awakened” by this internal logic and the magnetic flux from the Hall element is evaluated

against the predefined thresholds. This device requires the presence of both south and north polarity magnetic fields for operation. In the presence of a south polarity field of sufficient strength, the device output latches on, and only switches off when a north polarity field of sufficient strength is present.

While in the “Sleep” cycle the output transistor is latched in its previous state. The design has been optimized for service in applications requiring extended operating lifetime in battery powered systems.

Glossary of Terms

MilliTesla (mT), Gauss	Units of magnetic flux density: 1mT = 10 Gauss
RoHS	Restriction of Hazardous Substances
Operating Point (B_{OP})	Magnetic flux density applied on the branded side of the package which turns the output driver ON ($V_{OUT} = V_{DSon}$)
Release Point (B_{RP})	Magnetic flux density applied on the branded side of the package which turns the output driver OFF ($V_{OUT} = \text{high}$)

Pin Definitions and Descriptions

SOT Pin №	SIP Pin №	Name	Type	Function
1	1	V _{DD}	Supply	Supply Voltage Pin
2	3	OUT	Output	Open Drain Output Pin
3	2	GND	Ground	Ground Pin

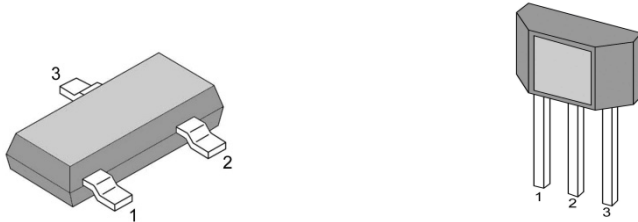

Internal Timing Circuit

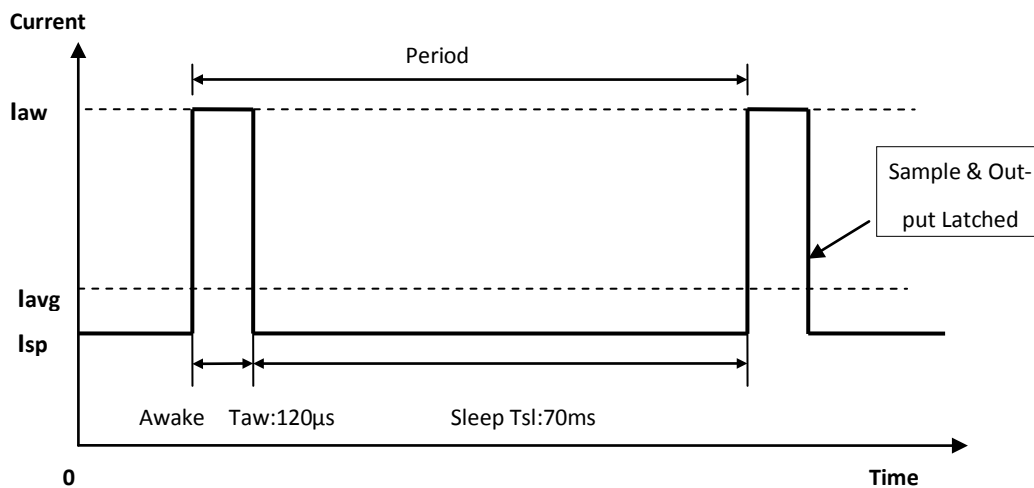

Absolute Maximum Ratings

Parameter	Symbol	Value	Units
Supply Voltage	V _{DD}	6	V
Supply Current	I _{DD}	50	mA
Output Voltage	V _{OUT}	28	V
Output Current	I _{OUT}	50	mA
Operating Temperature Range	T _A	-40 to 150	°C
Storage Temperature Range	T _S	-50 to 160	°C
ESD Sensitivity		4000	V

Operating Temperature Range	Symbol	Value	Units
Temperature Suffix “E”	T _A	-40 to 85	°C
Temperature Suffix “K”	T _A	-40 to 125	°C
Temperature Suffix “L”	T _A	-40 to 150	°C

Exceeding the absolute maximum ratings may cause permanent damage. Exposure to absolute-maximum- rated conditions for extended periods may affect device reliability.

General Electrical Specifications

DC Operating Parameters T_A = 25°C, V_{DD}= 2.75V

Parameter	Symbol	Test Conditions	Min	Typ	Max	Units
Supply Voltage	V _{DD}	Operating	2.5	3	5.5	V
Supply Current	I _{DD}	Average		5		μA
Output Current	I _{OUT}				1.0	mA
Saturation Voltage	V _{SAT}	I _{OUT} =1mA			0.4	V
Awake mode time	T _{AW}	Operating		175		μS
Sleep mode time	T _{SL}	Operating			70	mS

Magnetic Specifications

DC Operating Parameters V_{DD} = 2.5 to 5.5V (unless otherwise specified)

Package	Parameter	Symbol	Test Conditions	Min	Typ	Max	Units
UA	Operating Point	B _{OP}	T _a =25°C V _{dd} =2.75V DC	5	30	60	G
	Release Point	B _{RP}		-60	-30	-5	G
	Hysteresis	B _{HYST}			60		G
SO	Operating Point	B _{OP}	T _a =25°C V _{dd} =2.75V DC	-60	-30	-5	G
	Release Point	B _{RP}		5	30	60	G
	Hysteresis	B _{HYST}			60		G

Output Behavior versus Magnetic Pole

DC Operating Parameters $T_A = -40^{\circ}\text{C}$ to 150°C , $V_{DD} = 2.5$ to 5.5V (unless otherwise specified)

Test Conditions (UA)	Test Conditions (SO)	OUT
$B < B_{RP}$	$B > B_{RP}$	High
$B > B_{OP}$	$B < B_{OP}$	Low

The SOT-23 device is reversed from the UA package. The SOT-23 output transistor will be turned on (drops low) in the presence of a sufficiently strong North pole magnetic field applied to the marked face and turned off (hoists high) in the presence of a sufficiently strong South pole magnetic field.

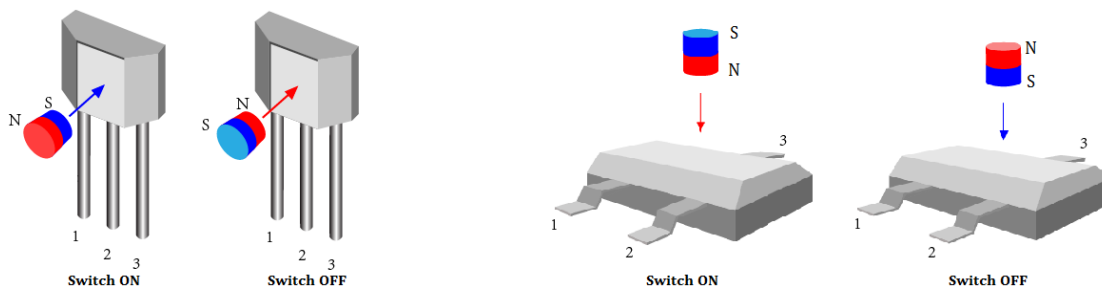

Unique Features

CMOS Hall IC Technology

The chopper stabilized amplifier uses switched capacitor techniques to eliminate the amplifier offset voltage, which, in bipolar devices, is a major source of temperature sensitive drift. CMOS makes this advanced technique possible. The CMOS chip is also much smaller than a bipolar chip, allowing very sophisticated circuitry to be placed in less space. The small chip size also contributes to lower physical stress and less power consumption.

ESD Protection

Human Body Model (HBM) tests according to: Mil. Std. 883F method 3015.7

Parameter	Symbol	Limit Values		Unit	Notes
		Min	Max		
ESD Voltage	VESD		± 4	kV	

ESD Precautions

Electronic semiconductor products are sensitive to Electro Static Discharge (ESD). Always observe Electro Static Discharge control procedures whenever handling semiconductor products.

Package Information

Package TO92 3-Pin SIP:

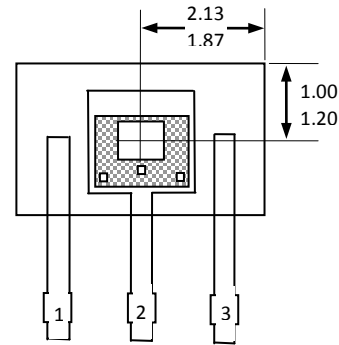
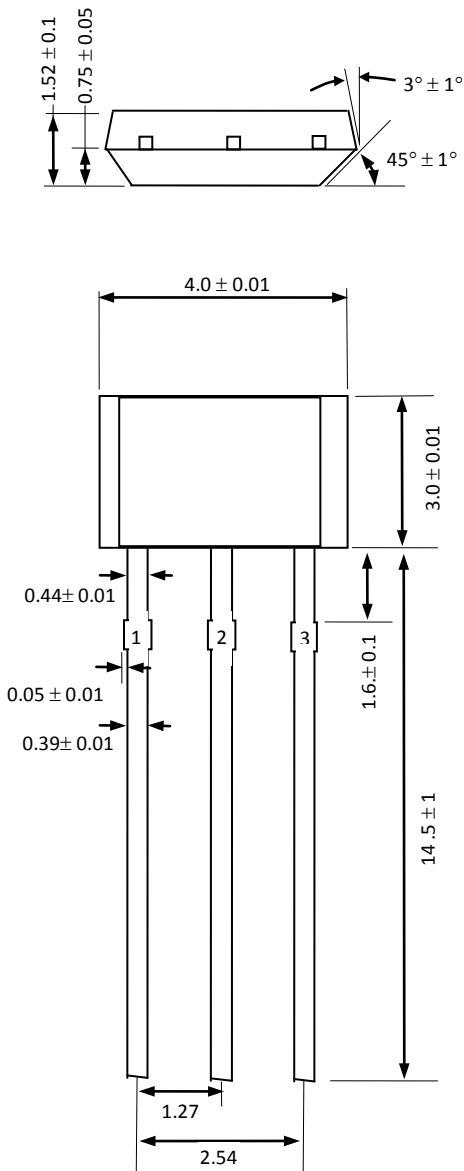

Sensor Location

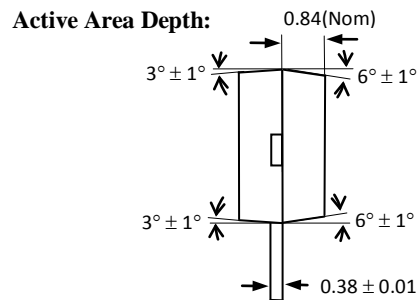

Notes:

- 1). Controlling dimension : mm ;
- 2). Leads must be free of flash and plating voids ;
- 3). Do not bend leads within 1 mm of lead to package interface ;
- 4). PINOUT: Pin 1 V_{DD}
Pin 2 GND
Pin 3 Output

Package 3-Pin SOT-23:

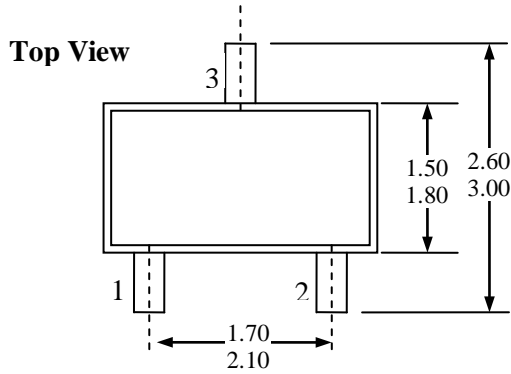

Notes:

1. **PINOUT:** Pin 1 V_{DD}
Pin 2 Output
Pin 3 GND
2. All dimensions are in millimeters ;

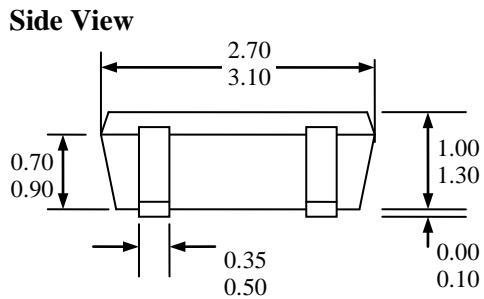

End View

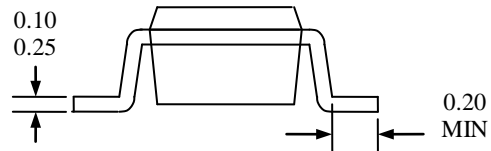

SOT-23 Package Hall Location:

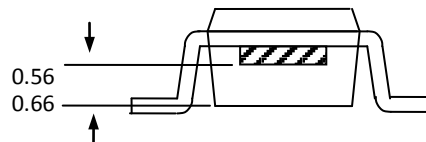
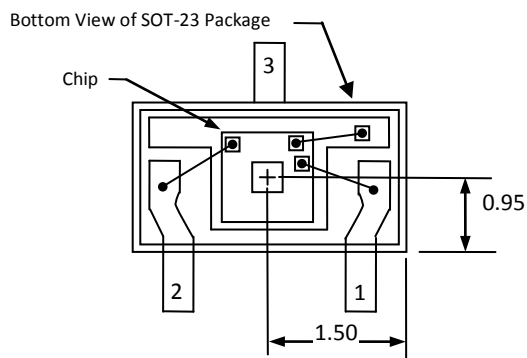

Package 3-Pin TSOT-23:

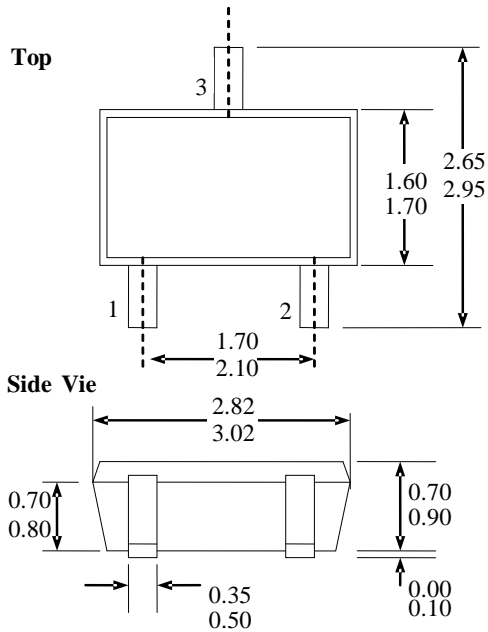

Notes

- 1). PINOUT: Pin 1 V_{DD}
Pin 2 Output
Pin 3 GND
- 2). All dimensions are in millimeters;

End

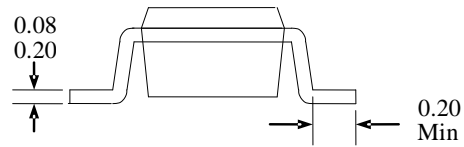

TSOT-23 Package Hall Location:

Bottom View of TSOT-23 Package

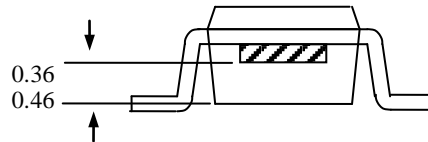
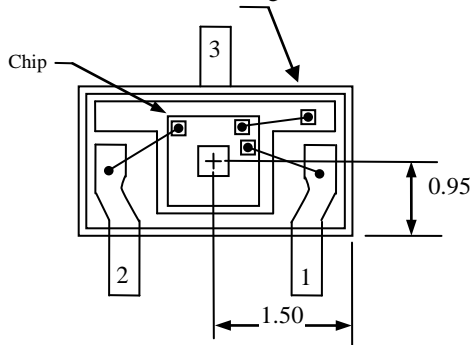

Ordering Information

Part No.	Pb-free	Temperature Code	Package Code	Packing
SS2412ESOT	YES	-40°C to 85°C	SOT-23	7-in. reel, 3000 pieces/ reel
SS2412ESTT	YES	-40°C to 85°C	TSOT-23	7-in. reel, 3000 pieces/ reel
SS2412EUA	YES	-40°C to 85°C	TO-92	Bulk, 1000 pieces/ bag
SS2412KSOT	YES	-40°C to 125°C	SOT-23	7-in. reel, 3000 pieces/ reel
SS2412KSTT	YES	-40°C to 125°C	TSOT-23	7-in. reel, 3000 pieces/ reel
SS2412KUA	YES	-40°C to 125°C	TO-92	Bulk, 1000 pieces/ bag
SS2412LSOT	YES	-40°C to 150°C	SOT-23	7-in. reel, 3000 pieces/ reel
SS2412LSTT	YES	-40°C to 150°C	TSOT-23	7-in. reel, 3000 pieces/ reel
SS2412LUA	YES	-40°C to 150°C	TO-92	Bulk, 1000 pieces/ bag
