

30C25

definite purpose contactor



- 30C 25FLA Definite Purpose Contactor
- Robust 1 - 4 Pole Contactor
- Arc Covers as standard
- Industry Standard Mounting
- RoHS Compliant
- UL File No: E61703



Contact Data

Table 1

- Arrangements: 1 Form X (SPST-NO-DM) with or without shunt
 2 Form X (DPST-NO-DM)
 3 Form X (3PST-NO-DM)
 4 Form X (4PST-NO-DM)

Material: AgCdO, AgSnOInO

Model No	Full Load Amps (FLA)	Poles	Line Voltage (VAC)	Locked Rotor Amps (LRA)	Resistive Amps	Max. HP		
						Voltage	1 Phase	3 Phase
30C25-1021	25	1	120	150	35	120	1	
			240/277	150		240	2	
			480	125				
			600	100				
30C25-1022	25	2	120	150	35	120	1	
			240/277	150		240	2	
			480	125				
			600	100				
30C25-1023	25	3	120	150	35	110/120	2	
			240/277	150		200/240	5	7.5
			480	125		480		15
			600	100		600		20
30C25-1024	25	4	120	150	35	110/120	2	
			240/277	150		240	5	7.5
			480	125		480		15
			600	100		600		20

FLA rating tested for 30,000 cycles of endurance at 240/480/600VAC per UL508.
 Resistive Heat rating tested for 250,000 cycles at 277VAC.
 LRA rating tested for 6000 cycles of Locked Rotor endurance per UL508.



30C25

definite purpose contactor



General Specifications

Table 2

Initial Operate Time	mS	20	Terminations	Coil Terminals	1 pole 2 pole 3 pole 4 pole	0.250" QC + #6-32 screw (dual 0.250" QC optional) - per terminal
Release Time	mS	10 (typical)				
Bounce Time	mS	≤ 10				
Arc Cover		Standard				
Insulation System		UL Class B 130°C				
Initial Dielectric Strength			Power Terminals	1 pole 2 pole	#10-32 screw or #14-4 box lug + Dual 0.250" QC	
between contacts and coil	VAC	2200				
between poles	VAC	2200 (includes shunt)				
between open contacts	VAC	2200		3 pole 4 pole	#10-32 screw or #14-4 box lug + Quad 0.250" QC	
Temperature Range	°C	-40 ... +65	Recommended Tightening Torque	#10-32	22 in.lbf (2.49 Nm)	
Unit Weight (approx.)				box lug	40 in.lbf (4.52 Nm)	
	1 pole	0.5 lb	Wire size	#10-32	16-8AWG*	
	2 pole	0.6 lb		box lug	14-4AWG	
	3 pole	1.0 lb				
	4 pole	1.24 lb				

* Must use ring terminals

Ordering Codes

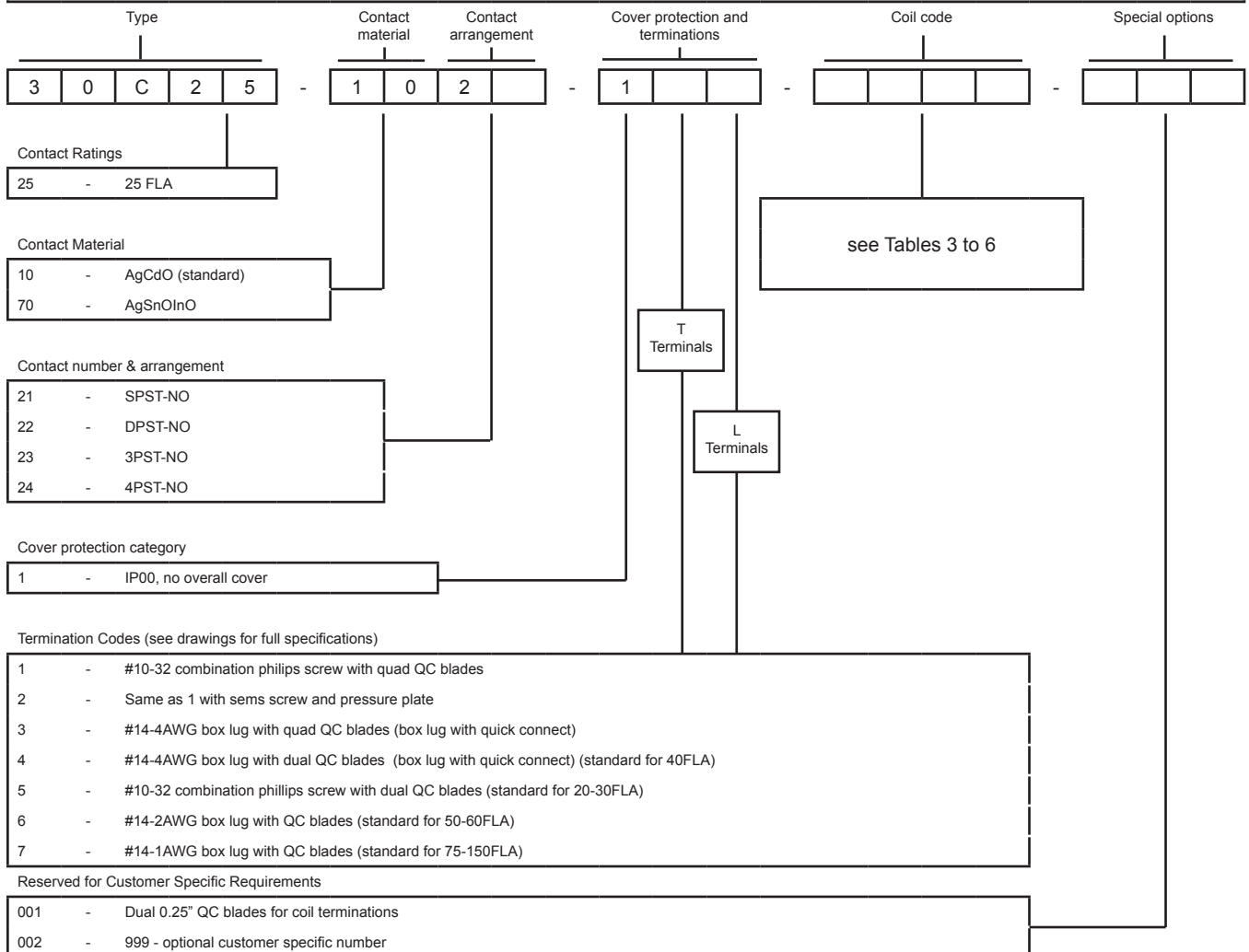

30C25

definite purpose contactor



Coil Data (30C25-1021)

Table 3

Voltage: 24-277VAC 50/60Hz. See coil data below. (480VAC available but not UL approved)

Insulation Class: UL Class B (130°C)

Coil Voltage Code	Rated Voltage 50/60Hz	Coil Resistance (Ohms)	Coil Operating Voltage (VAC)			Minimum Inrush		Nominal Coil Power	
			Must Release	Must Operate	Max Voltage	VA @ 50Hz	VA @ 60Hz	VA @ 50Hz	VA @ 60Hz
5024	24	18	6	18	30	31	28	6	5
5120	120	420	20	88	132	31	28	6	5
5230	208/240	1800	40	177	264	31	28	6	5
5277	277	2500	50	221	300	31	28	6	5
5480	480	8000	100	380	528	31	28	6	5

Coil Data (30C25-1022)

Table 4

Voltage: 24-277VAC 50/60Hz. See coil data below. (480VAC available but not UL approved)

Insulation Class: UL Class B (130°C)

Coil Voltage Code	Rated Voltage 50/60Hz	Coil Resistance (Ohms)	Coil Operating Voltage (VAC)			Minimum Inrush		Nominal Coil Power	
			Must Release	Must Operate	Max Voltage	VA @ 50Hz	VA @ 60Hz	VA @ 50Hz	VA @ 60Hz
5024	24	11	6	18	30	33	30	8	6.5
5120	120	237	20	88	132	33	30	8	6.5
5230	208/240	1000	40	177	264	33	30	8	6.5
5277	277	1600	50	221	300	33	30	8	6.5
5480	480	4200	100	380	528	33	30	8	6.5

Coil Data (30C25-1023)

Table 5

Voltage: 24-277VAC 50/60Hz. See coil data below. (480VAC available but not UL approved)

Insulation Class: UL Class B (130°C)

Coil Voltage Code	Rated Voltage 50/60Hz	Coil Resistance (Ohms)	Coil Operating Voltage (VAC)			Minimum Inrush		Nominal Coil Power	
			Must Release	Must Operate	Max Voltage	VA @ 50Hz	VA @ 60Hz	VA @ 50Hz	VA @ 60Hz
5024	24	7	6	18	30	65	60	7.5	6
5120	120	180	20	88	132	65	60	7.5	6
5230	208/240	719	40	177	264	65	60	7.5	6
5277	277	900	65	220	300	65	60	7.5	6
5480	480	3100	150	384	520	65	60	7.5	6

Coil Data (30C25-1024)

Table 6

Voltage: 24-277VAC 50/60Hz. See coil data below. (480VAC available but not UL approved)

Insulation Class: UL Class B (130°C)

Coil Voltage Code	Rated Voltage 50/60Hz	Coil Resistance (Ohms)	Coil Operating Voltage (VAC)			Minimum Inrush		Nominal Coil Power	
			Must Release	Must Operate	Max Voltage	VA @ 50Hz	VA @ 60Hz	VA @ 50Hz	VA @ 60Hz
5024	24	6	6	18	30	62	59	9	7
5120	120	150	20	88	132	62	59	9	7
5230	208/240	600	40	177	264	62	59	9	6
5277	277	750	65	220	300	62	59	9	7
5480	480	4200	150	384	520	62	59	9	7



30C25

definite purpose contactor



Overall Dimensions

Fig. 1

1 Pole

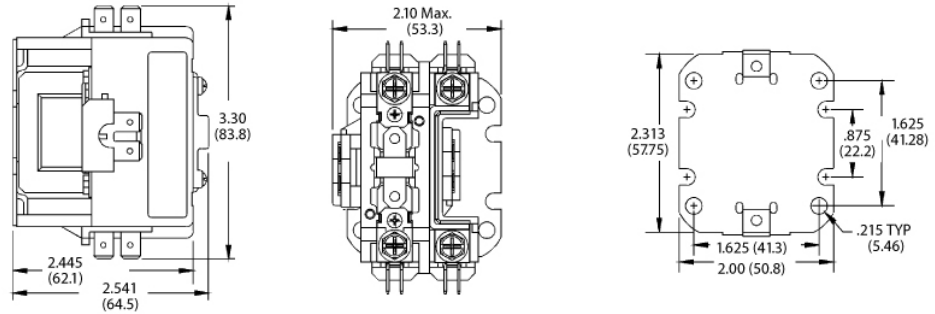

2 Pole

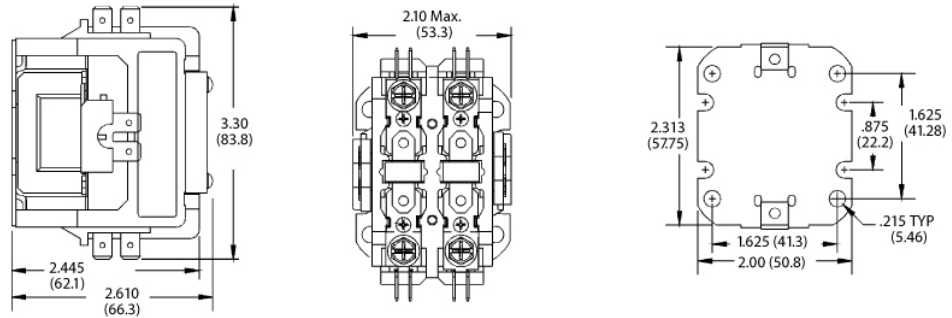

3 Pole

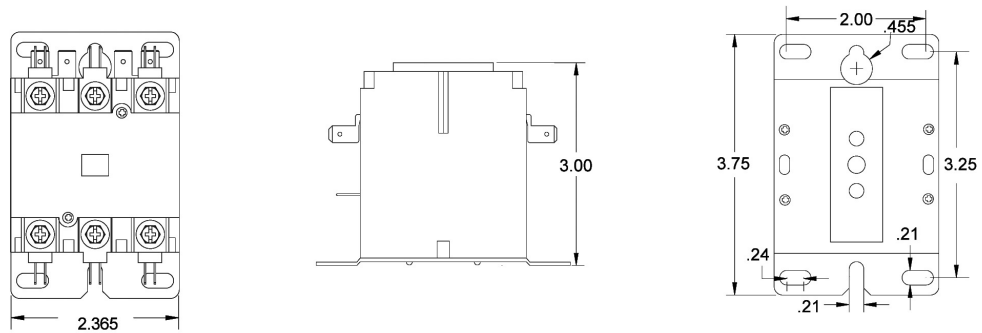

4 Pole

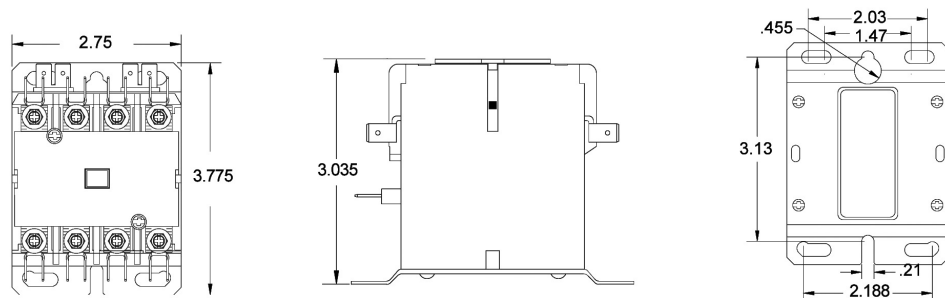

Dimensions in inches (millimetres)



30C25

definite purpose contactor



Power Terminations	
Termination Codes: 1 & 5 Standard on 20-30FLA #10-32 combination phillips/slotted and 5/16 hex head screw with #12 washer	
Termination Code: 2 Optional on 20-40FLA #10-32 sems screw with pressure plate	
Termination Codes: 3 & 4 Box Lug 14-4 AWG (Cu/Al) Dimension in inches	

Auxillary Switches for 3 & 4 pole contactors

Description	Contact Arrangement	Termination	Part Number
Single unit interlock configuration. One on each side - max set up to two switches	SPST-NO + SPST-NC break before make	0.250" QC	30CA1Q
Single unit interlock configuration. One on each side - max set up to two switches	SPST-NO + SPST-NC break before make	#6-32 screw terminals	30CA1S
SPDT circuit One switch per side	SPDT	0.250" QC	30CB1Q
SPDT circuit Two switches per side	2 x SPDT	0.250" QC	30CB2S

Auxillary Switch Contact Rating						
SPST-NO+SPST-NC					SPDT	
Voltage Rating	120VAC	240VAC	480VAC	600VAC	120VAC	250VAC
Amps - Break	3.00	1.50	0.75	0.60	0.5	0.25
Amps - Make	30	15	7.5	6	15	15
Amps - continuous	10	10	10	10	10	10

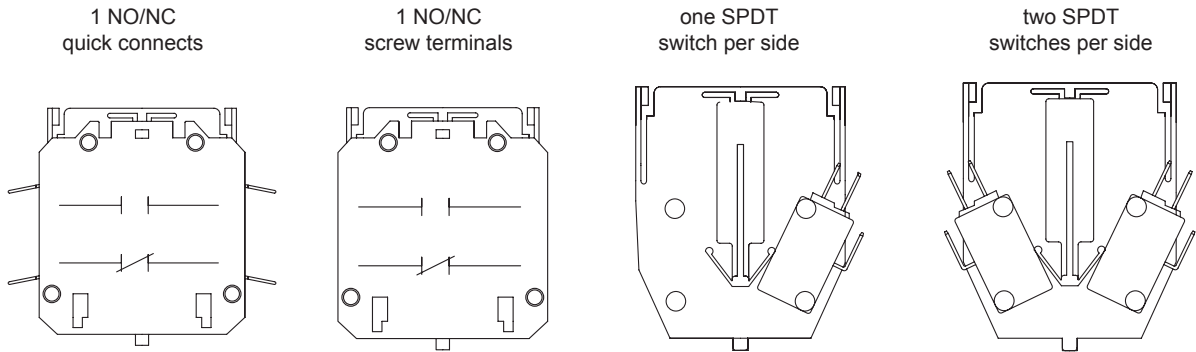

American Electronic Components Inc., 1100 Lafayette St., Elkhart, IN 46516

Toll Free: (888) 847-6552, Tel: (574) - 295-6330 www.aecensors.com

Specifications and availability are liable to change without notice.

Page 5 of 5 www.aecensors.com Sales Department Tel: (888) 847-6552

Ref: 30C25 101711JHM

