

isc Silicon NPN Power Transistor

KSD5010

DESCRIPTION

- High Breakdown Voltage-  
:  $V_{CBO} = 1500V$  (Min)
- High Switching Speed
- High Reliability
- Built-in Damper Diode

APPLICATIONS

- Designed for color TV horizontal output applications

ABSOLUTE MAXIMUM RATINGS( $T_a=25^{\circ}C$ )

SYMBOL	PARAMETER	VALUE	UNIT
$V_{CBO}$	Collector-Base Voltage	1500	V
$V_{CEO}$	Collector-Emitter Voltage	800	V
$V_{EBO}$	Emitter-Base Voltage	6	V
$I_C$	Collector Current- Continuous	2.5	A
$I_{CP}$	Collector Current-Peak	10	A
$P_C$	Collector Power Dissipation @ $T_C=25^{\circ}C$	50	W
$T_J$	Junction Temperature	150	$^{\circ}C$
$T_{stg}$	Storage Temperature Range	-55~150	$^{\circ}C$

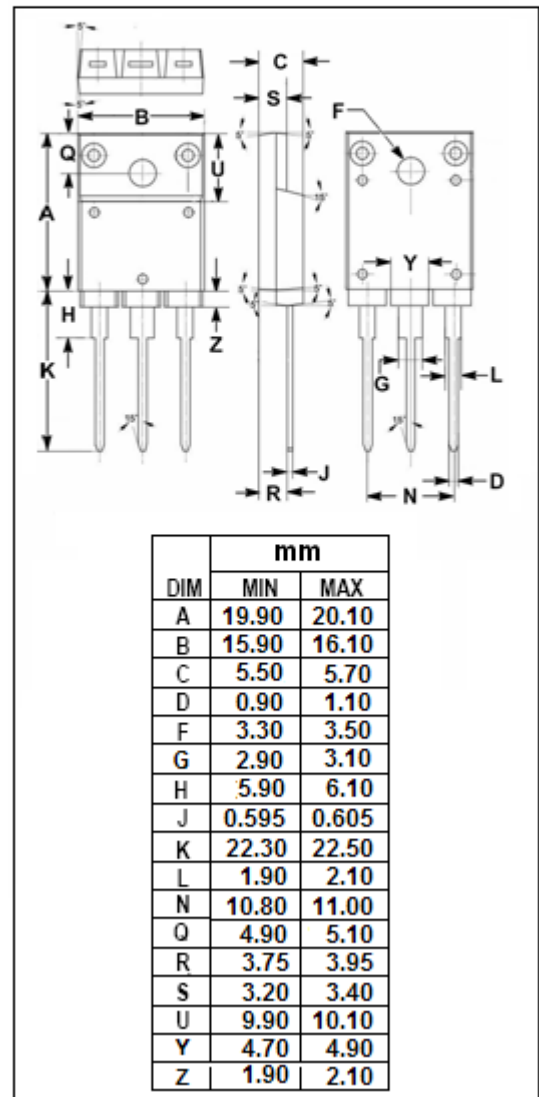
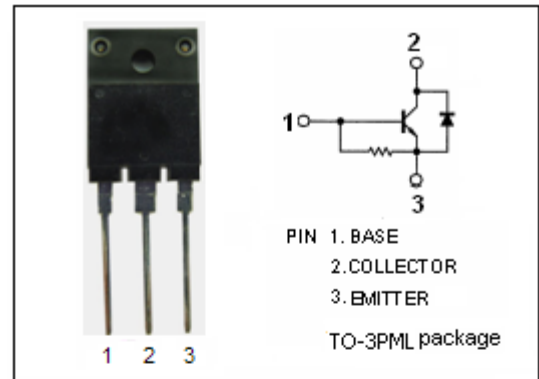

## isc Silicon NPN Power Transistor

## KSD5010

## ELECTRICAL CHARACTERISTICS

 $T_C=25^{\circ}\text{C}$  unless otherwise specified

SYMBOL	PARAMETER	CONDITIONS	MIN	TYP.	MAX	UNIT
$V_{CE(sat)}$	Collector-Emitter Saturation Voltage	$I_C=2\text{A}; I_B=0.6\text{A}$			8.0	V
$V_{BE(sat)}$	Base-Emitter Saturation Voltage	$I_C=2\text{A}; I_B=0.6\text{A}$			1.5	V
$I_{CBO}$	Collector Cutoff Current	$V_{CB}=800\text{V}; I_E=0$			10	$\mu\text{A}$
$I_{EBO}$	Emitter Cutoff Current	$V_{EB}=4\text{V}; I_C=0$	40		130	mA
$h_{FE}$	DC Current Gain	$I_C=0.5\text{A}; V_{CE}=5\text{V}$	8			
$f_T$	Current-Gain—Bandwidth Product	$I_C=0.5\text{A}; V_{CE}=10\text{V}$		3		MHz
$V_{ECF}$	C-E Diode Forward Voltage	$I_F=2.5\text{A}$			2.0	V
$t_f$	Fall Time	$I_C=2\text{A}, I_{B1}=0.6\text{A}; I_{B2}=-1.2\text{A}$ $R_L=100\Omega; V_{CC}=200\text{V}$			0.4	$\mu\text{s}$