

Rev	AWO #	Description	Date	Appr
-		RELEASED	5/03/10	

APPROVED: \_\_\_\_\_  
 DATE: \_\_\_\_\_ TITLE: \_\_\_\_\_

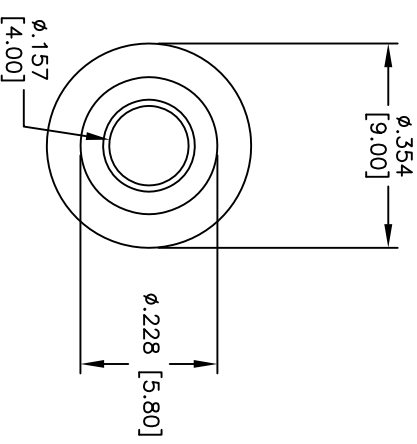
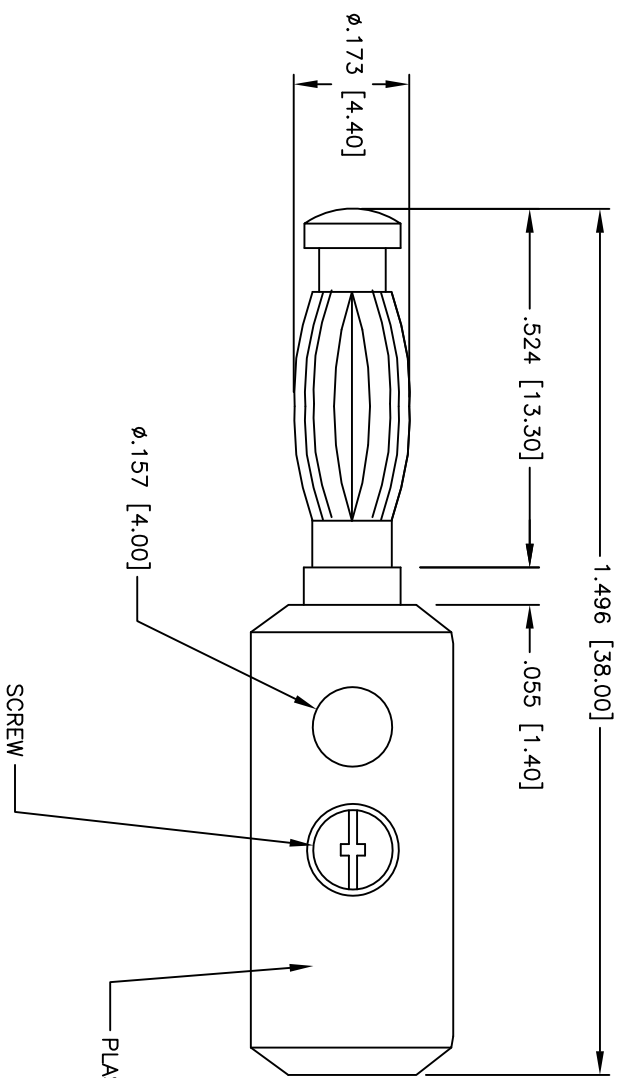

**SPECIFICATIONS:**

Material:  
 Brass, ASTM B16, Alloy C 36000, 1/2 hard  
 Plating:  
 Gold flash over Nickel underplate overall  
 Environmental:  
 Lead free, RoHS compliant



UNLESS OTHERWISE SPECIFIED ALL DIMENSIONS ARE IN INCHES [MM]	
TOLERANCES: EXCEPT AS NOTED	
INCHES	HOLES
.X ± .10	Ø.X ± .10
.XX ± .020	Ø.XXX ± .015
.XXX ± .015	Ø.XXX ± .010
APPROVALS	DATE
DRAWN	DY
CHECKED	
APPROVED	

**ADAM TECH**  
 909 Rahway Avenue, Union, NJ 07083  
 Phone: 908-687-5000 Fax: 908-687-5710

**BANANA PLUG**

TITLE	SIZE	PART NO.	REV.
BANANA PLUG	X	BP-003	-
REF:	SCALE:	NTS	SHEET 1 OF 1