

PROPER USE GUIDELINES

Cumulative Trauma Disorders can result from the prolonged use of manually powered hand tools. Hand tools are intended for occasional use and low volume applications. A wide selection of powered application equipment for extended-use, production operations is available.

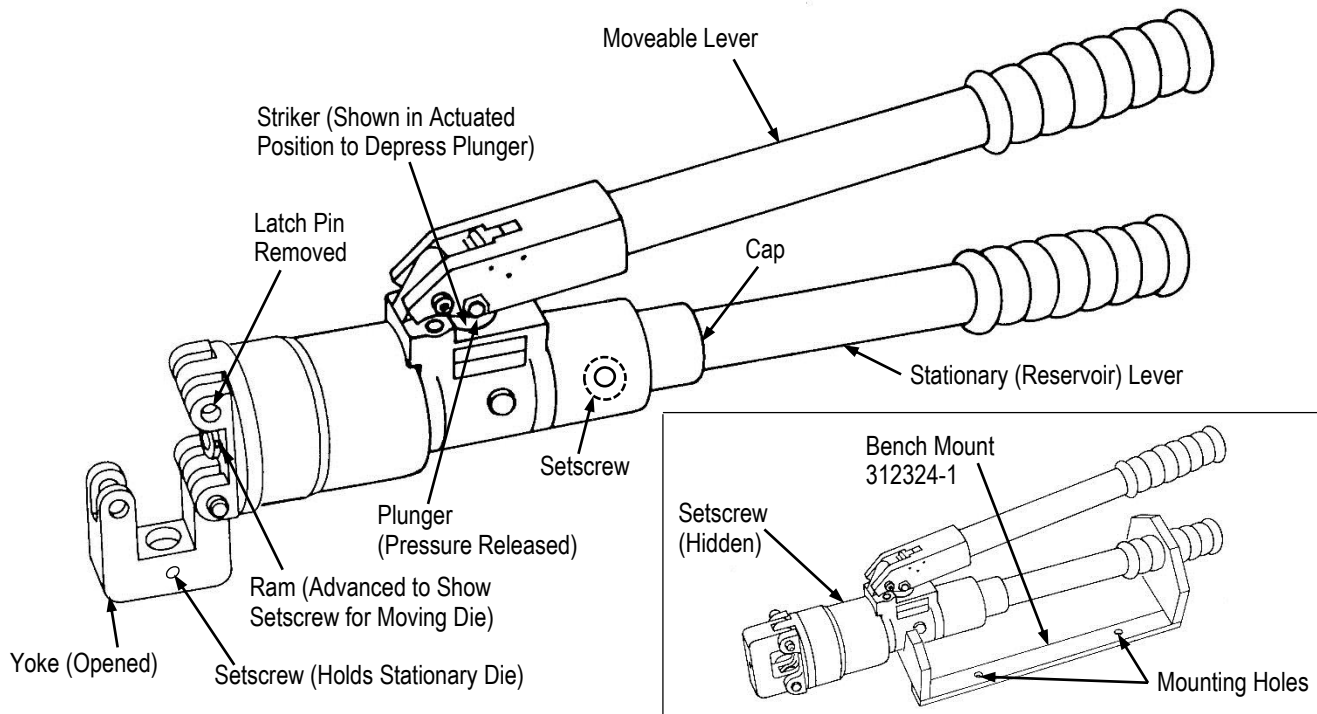

Figure 1

1. INTRODUCTION

Hydraulic Hand Tool 59973-1 is designed for crimping terminals and splices in wire size ranges 6 mm²-100 mm² [8 through 4/0 AWG]. Read these instructions thoroughly before crimping any terminals or splices.

i NOTE
Dimensions in this instruction sheet are in metric units [with U.S. customary units in brackets]. Figures and illustrations are for identification only and are not drawn to scale.

Reasons for reissue of this instruction sheet are provided in Section 7, REVISION SUMMARY.

2. DESCRIPTION (Figure 1)

The hand tool has a stationary lever and a moveable lever. These levers are compressed to pump hydraulic fluid behind the ram, moving it forward and thereby closing the dies. After the crimping is complete, the moveable lever is turned to depress the plunger. The moving die retracts to its original position, completing the crimping cycle.

i NOTE
The tool may be bench mounted by sliding it into Bench Mount 312324-1 (purchased separately) and securing it tightly with the mount setscrew. The mount has four holes for securing it to a bench. See Figure 1, inset.

3. DIE INSERTION AND REMOVAL

1. Strip wires to dimensions specified on instruction sheet packaged with dies.
2. Insert terminal or splice in stationary die according to instruction sheet packaged with dies.

4. CRIMPING PROCEDURE

1. Strip wires to dimensions specified on instruction sheet packaged with dies.
2. Insert terminal or splice in stationary die according to instruction sheet packaged with dies.

**CAUTION**

Ensure latch pin is fully inserted before operating hand tool.

3. Pump moveable lever until moving die grips terminal or splice.

**CAUTION**

Do not deform wire barrel of terminal or splice.

4. Insert stripped wire into wire barrel of terminal or splice.
5. Continue pumping moveable lever. A slight click may be heard, indicating the pump has shifted into the high-pressure stage. Continue pumping moveable lever. When dies have bottomed, an audible “pop” will be heard. This indicates that the crimp is complete.
6. Retract moveable die by opening the movable handle to the full open position, turn the movable handle (to actuate striker). **DO NOT TURN THE MOVABLE HANDLE WHILE IN THE CLOSED POSITION AS YOU WILL DAMAGE THE PLUNGER (PRESSURE RELEASE)**, compress handles to depress plunger (pressure release). Movable die will now retract. See Figure 1.
7. Remove latch pin, open yoke, and remove crimped terminal or splice.

**NOTE**

If terminal or splice sticks in die after crimping, apply a rocking motion action to remove it from the die.

8. Inspect crimped terminal or splice according to inspection procedure on instruction sheet packaged with the dies.

5. MAINTENANCE/INSPECTION

These instructions have been approved by TE Connectivity Design, Production, and Quality Control Engineers to provide documented maintenance and inspection procedures. Through test laboratories and the inspection production assembly, the procedures described herein have been established to ensure quality and reliability of TE crimping tools.

Each crimping tool is assembled and inspected before shipment. TE recommends that the tool be inspected immediately upon its arrival at your facility, and at regularly scheduled intervals, to ensure the tool has not been damaged during handling and use. Frequency of inspection depends upon the following: care, amount of use, and handling of the tool; type and size of products crimped; degree of operator skill; and environmental conditions.

**DANGER**

Make sure hydraulic pressure is released before following maintenance and inspection procedures, unless otherwise specified in the procedure.

5.1. Cleaning

It is recommended that each operator of the tool be made aware of, and responsible for, the following steps:

1. Remove all foreign particles with a clean, soft brush or clean, soft lint-free cloth. **DO NOT** use hard or abrasive objects that could damage the tool. Make sure the proper retaining pins are in place and secured with the proper retaining rings. If foreign matter cannot be removed easily, or if the proper replacement parts are not available, return the tool to your supervisor.
2. Make certain all pivot points and bearing surfaces are protected with a THIN coat of any good SAE 20 motor oil. Do not oil excessively. When the tool is not in use, keep the handles closed to prevent objects from becoming lodged in the crimping chamber, and store the tool in a clean, dry area.

5.2. Hydraulic Fluid Level Inspection (Figure 2)

Remove tool from bench mount; then proceed as follows:

1. Turn tool upside down and clamp it in a vise so that tool handles are in an upright position.

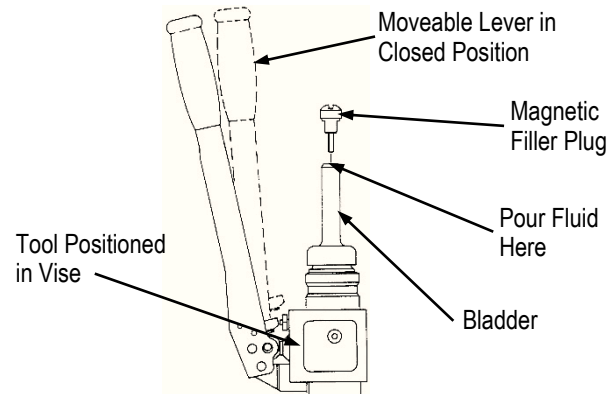

Figure 2

2. Release all pressure in tool according to instructions in step 6 of Section 4, CRIMPING PROCEDURE.
3. Release striker and allow moveable lever to close until it stops.

NOTE

Keep handle in **CLOSED** position for remaining steps in this inspection.

4. Loosen setscrew in cap of stationary (reservoir) lever. See Figure 1.
5. With view from handle grip end, turn handle **COUNTERCLOCKWISE** and remove entire reservoir lever to expose bladder.
6. Remove magnetic filler plug and wipe clean. If bladder is full, no further check is necessary and tool can be re-assembled. If fluid level is low, proceed to Step 7.
7. Fill bladder with fluid ▲. Use care to prevent air bubbles from forming while pouring the fluid.
8. Refill bladder to point of overflow, and replace filler plug.
9. Re-assemble reservoir handle and tighten cap setscrew. Tool is now ready for use.

5.3. Periodic Inspection

It is recommended at least one inspection a month. The inspection frequency should be based on the amount of use, ambient working conditions, operator training and skill, and your company's established standards.

A. Lubrication

Keep all pins, pivot points, and bearing surfaces lubricated with SAE 20 motor oil as follows:

- Tool used in daily production - lubricate daily
- Tool used daily (occasionally) - lubricate weekly
- Tool used weekly - lubricate monthly

Wipe excess oil from tool, particularly from crimping area. Oil transferred from the crimping area onto certain terminations may affect the electrical characteristics of an application.

B. Visual Inspection

1. Make certain all retaining pins are in place and secured with retaining rings. If replacements are necessary, refer to parts listed in Figure 3.
2. Inspect head assembly for worn, cracked, or broken areas. If damage is evident, return the tool for evaluation and repair. See Section 6, REPLACEMENT AND REPAIR.

C. Crimping Pressure Inspection

Check the crimping pressure to ensure that dies are fully bottomed before pressure is reduced by the internal bypass valve. The inspection should be performed using each set of dies that will be used in the head.

▲ Recommended fluid is Dexron† II, a transmission fluid available in automotive parts and department stores. Dexron is a trademark.

1. Install dies according to Paragraph 3 and the instruction sheet packaged with the dies.
2. Select wire and terminal or splice appropriate for the dies being used.
3. Place terminal or splice in dies according to instruction sheet packaged with dies.
4. Perform crimping procedure as described in Steps 3 through 5 of Paragraph 4. Do NOT release hydraulic pressure at this time.
5. Check the clearance between bottoming surfaces of crimping dies. If clearance is 0.0254 mm [.001 in.] or less, bottoming is satisfactory. If clearance exceeds 0.0254 mm [.001 in.], the dies are considered as not bottoming (see Paragraph 6, REPAIR).

If the tool conforms to these inspection procedures, lubricate it with a THIN coat of any good SAE No.20 motor oil and return it to service.

6. REPLACEMENT AND REPAIR

Customer-replaceable parts are listed in Figure 3. A complete inventory should be stocked and controlled to prevent lost time when replacement of parts is necessary. Parts other than those listed should be replaced by TE to ensure quality and reliability. Order replacement parts through your TE Representative, or call 1-800-526-5142, or send a facsimile of your purchase order to 717-986-7605, or write to:

CUSTOMER SERVICE (038-035)
 TYCO ELECTRONICS CORPORATION
 PO BOX 3608
 HARRISBURG PA 17105-3608

For customer repair service, contact a TE Representative at 1-800-526-5136.

7. REVISION SUMMARY

- Updated document to corporate requirements
- Changed text in Paragraph 4.6

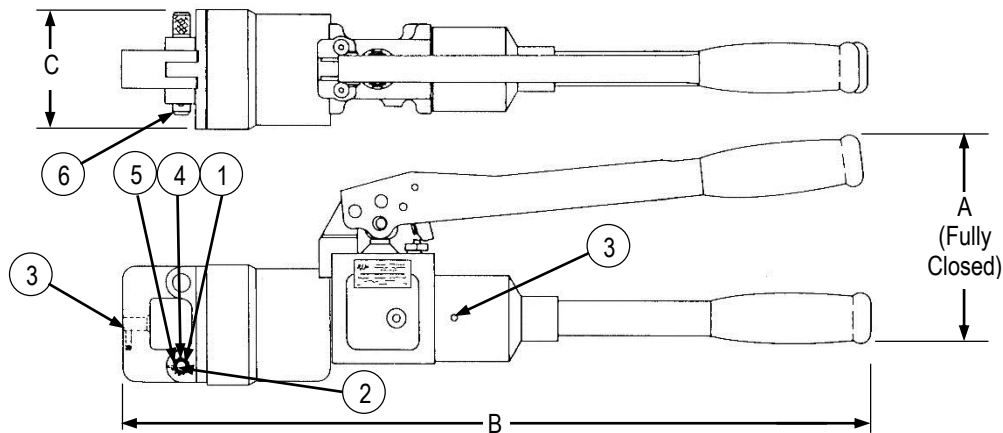

TOOL SPECIFICATIONS		REPLACEMENT PARTS			
DIMENSION	WEIGHT	ITEM	PART NO.	DESCRIPTION	QTY PER ASSY
A	15.4 [6.0]	1	301555	SPACER	1
B	571.5 [22.5]		301556	SPRING	1
C	79.25 [3.12]		23057-6	PLUNGER, Ball	1
			302312	PIN, Hinge	1
			21045-9	RING, Retaining	2
			306209-3	PIN, Latch	1
			5-21006-0	SETSCREW, 10-32 X ¼ L	1

Figure 3