

DC/DC Converter Controller

The KIA34063A/AF series is a monolithic control circuit containing the primary functions required for DC-to-DC converters. These devices consist of an internal temperature compensated reference, comparator, controlled duty cycle oscillator with an active current limit circuit, driver and high current output switch. This series was specifically designed to be incorporated in Step-Down and Step-Up and Voltage-Inverting applications with a minimum number of external components.

FEATURES

- Operation from 3.0V to 40V input.
- Low Standby Current.
- Current Limiting.
- Output Switch Current to 1.5A.
- Output Voltage Adjustable.
- Frequency Operation to 100kHz.
- Precision 2% Reference.

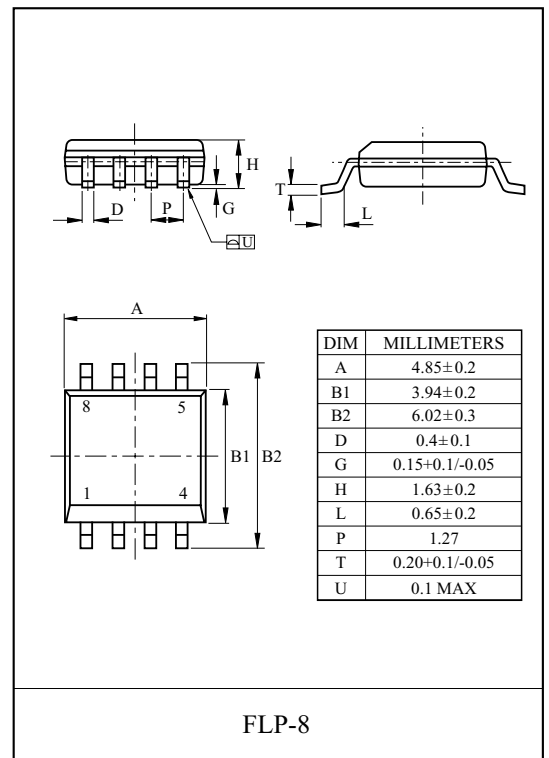
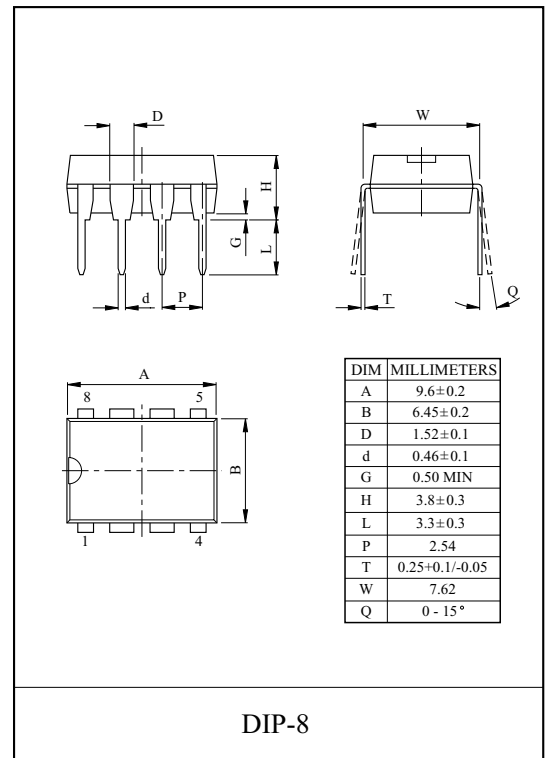
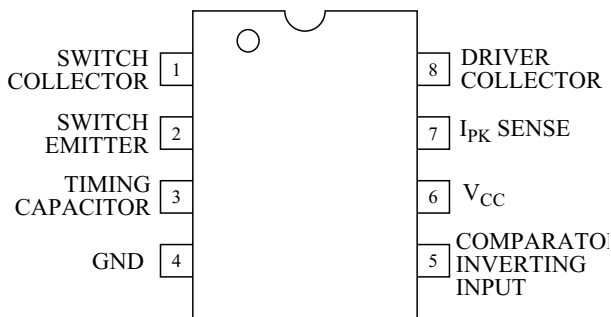

KIA34063A/AF

MAXIMUM RATINGS (Ta=25)

CHARACTERISTIC		SYMBOL	RATING	UNIT
Power Supply Voltage		V_{CC}	40	V
Comparator Input Voltage Range		V_{IR}	-30 40	V
Switch Collector Voltage		$V_{C(SWITCH)}$	40	V
Switch Emitter Voltage ($V_{PIN1}=40V$)		$V_{E(SWITCH)}$	40	V
Switch Collector to Emitter Voltage		$V_{CE(SWITCH)}$	40	V
Driver Collector Voltage		$V_{C(DRIVER)}$	40	V
Driver Collector Current (Note 1)		$I_{C(DRIVER)}$	100	mA
Switch Current		I_{SW}	1.5	A
Power Dissipation	KIA34063A	P_D	500	mW
	KIA34063AF		320	
Operating Temperature		T_{opr}	-30 75	
Storage Temperature		T_{stg}	-65 150	

Note 1) Maximum package power dissipation limits must be observed.

BLOCK DIAGRAM

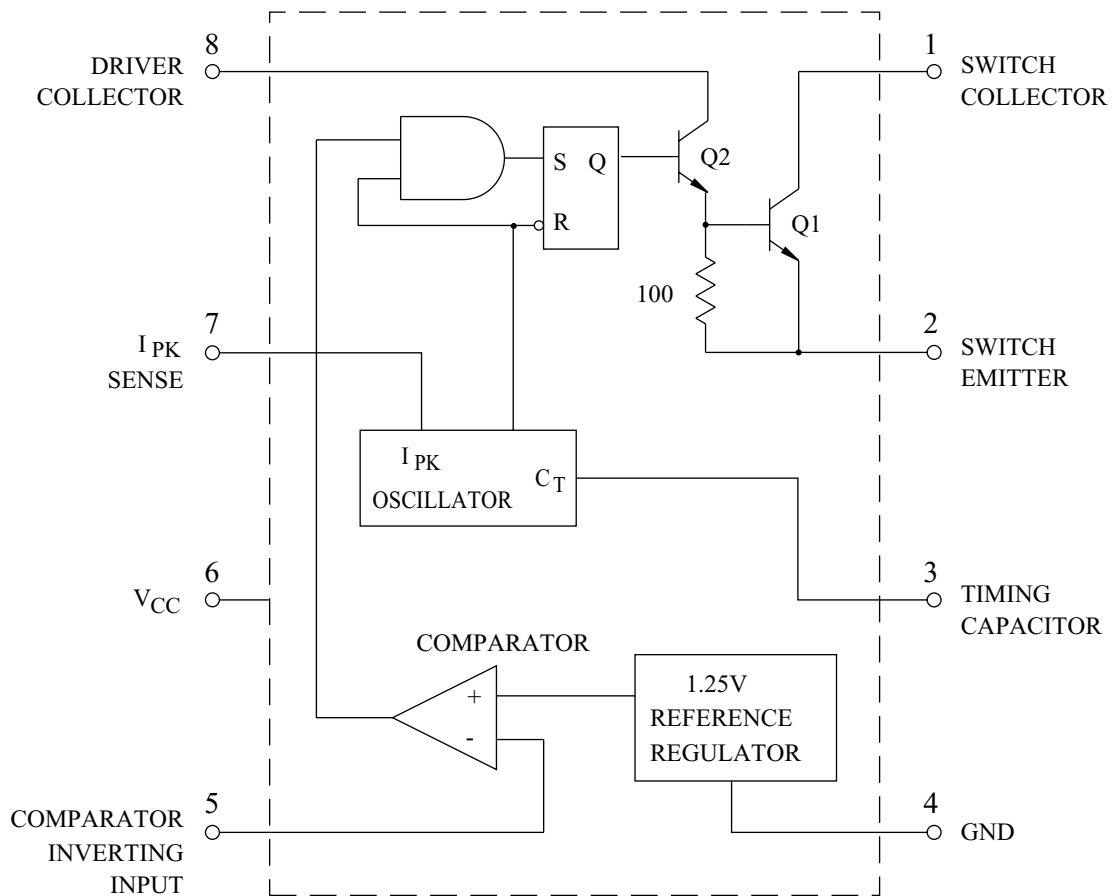

KIA34063A/AF

ELECTRICAL CHARACTERISTICS ($V_{CC}=5.0V$, $T_a=25$, unless otherwise specified)

OSCILLATOR SECTION

CHARACTERISTIC	SYMBOL	TEST CONDITION	MIN.	TYP.	MAX.	UNIT
Frequency	f_{OSC}	$V_{PIN5}=0V$, $C_T=1.0nF$	24	33	42	kHz
Charge Current	I_{CHG}	$V_{CC}=5.0$ 40V	24	35	42	μA
Discharge Current	I_{DISCHG}	$V_{CC}=5.0$ 40V	140	220	260	μA
Discharge to Charge Current Ratio	I_{DISCHG}/I_{CHG}	Pin 7 V_{CC}	5.2	6.5	7.5	-
Current Limit Sense Voltage	$V_{IPK(SENSE)}$	$I_{DISCHG}=I_{CHG}$	250	300	350	mV

OUTPUT SWITCH SECTION (Note 2)

CHARACTERISTIC	SYMBOL	TEST CONDITION	MIN.	TYP.	MAX.	UNIT
Saturation Voltage, Darlington Connection	$V_{CE(SAT1)}$	$I_{SW}=1.0A$, Pins 1, 8 Connection	-	1.0	1.3	V
Saturation Voltage (Note 3)	$V_{CE(SAT2)}$	$I_{SW}=1.0A$, Forced = 20 $R_{PIN8}=82$ to V_{CC}	-	0.45	0.7	V
DC Current Gain	h_{FE}	$I_{SW}=1.0A$, $V_{CE}=5.0A$,	50	75	-	-
Collector Off-State Current	$I_{C(OFF)}$	$V_{CE}=40V$	-	0.01	100	μA

COMPARATOR SECTION

CHARACTERISTIC	SYMBOL	TEST CONDITION	MIN.	TYP.	MAX.	UNIT
Threshold Voltage	V_{TH1}	$T_a=25$	1.225	1.25	1.275	V
Threshold Voltage	V_{TH2}	$T_a=T_{LOW}$ T_{HIGH}	1.21	-	1.29	V
Threshold Voltage Line Regulation	Reg line	$V_{CC}=3.0$ 40V	-	1.4	5.0	mV
Input Bias Current	I_{IB}	$V_{IN}=0$	-	-20	-400	nA

TOTAL DEVICE

CHARACTERISTIC	SYMBOL	TEST CONDITION	MIN.	TYP.	MAX.	UNIT
Supply Current	I_{CC}	$V_{CC}=5.0$ 40V, $C_T=1.0nF$, Pin 7= V_{CC} , Pin 2=GND, V_{PIN5} V_{TH} , remaining pins open	-	-	4.0	mA

Note) 2. Low duty cycle pulse techniques are used during test to maintain junction temperature as close to ambient temperature as possible.

3. If the output switch is driven into hard saturation (non-Darlington configuration) at low switch currents ($\approx 300mA$) and high driver currents ($\approx 30mA$), it may take up to 2.0 μs for it to come out of saturation. This condition will shorten the off time at frequencies $\approx 30kHz$, and is magnified at high temperatures. This condition does not occur with a Darlington configuration, since the output switch cannot saturate. If a non-Darlington configuration is used, the following output drive condition is recommended ;

$$\text{Forced } \beta \text{ of output switch : } \frac{I_C \text{ output}}{I_C \text{ driver}-7.0mA} \approx 10$$

* The 100 Ω resistor in the emitter of the driver device requires about 7.0mA before the output switch conducts.

KIA34063A/AF

APPLICATION CIRCUIT

(1) Step-up Converter

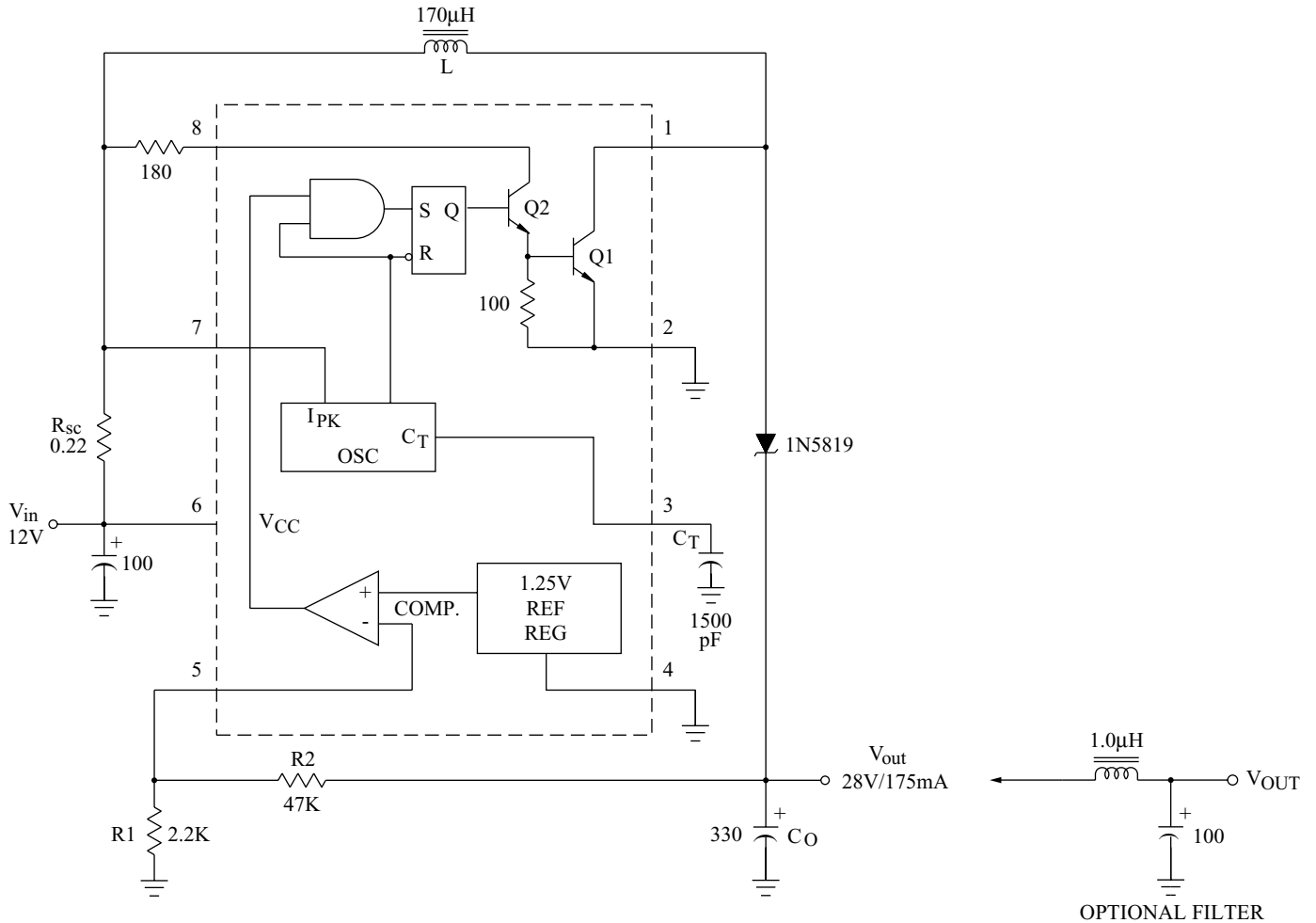

TEST	CONDITIONS	RESULTS
Line Regulation	$V_{IN}=8.0V$ to $16V$, $I_O=175mA$	$30mV= \pm 0.05\%$
Load Regulation	$V_{IN}=12V$, $I_O=75mA$ to $175mA$	$10mV= \pm 0.017\%$
Output Ripple	$V_{IN}=12V$, $I_O=175mA$	$400 mV_{pp}$
Efficiency	$V_{IN}=12V$, $I_O=175mA$	87.7%
Output Ripple With Optional Filter	$V_{IN}=12V$, $I_O=175mA$	$40 mV_{pp}$

KIA34063A/AF

(2) Step-Down Converter

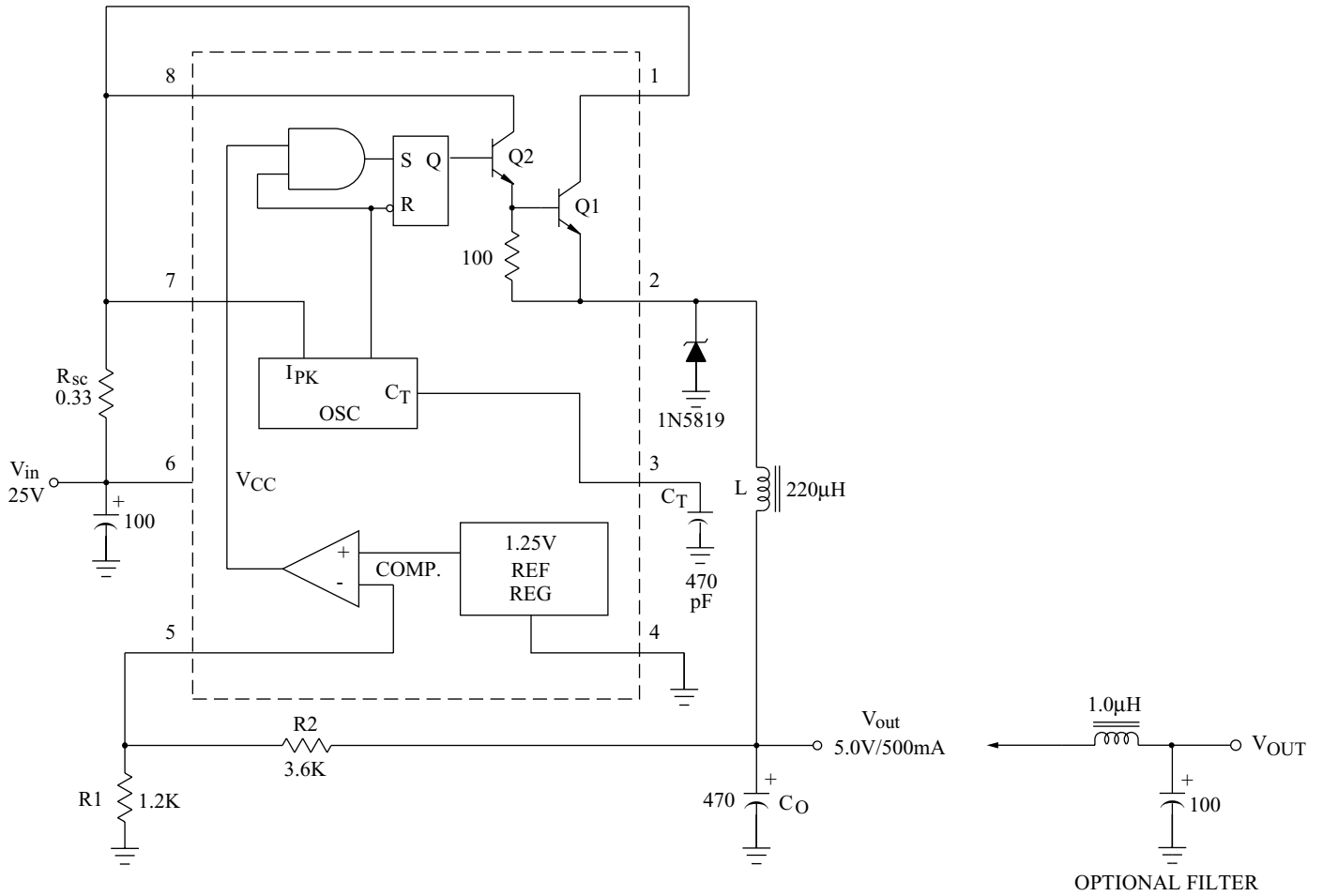

TEST	CONDITIONS	RESULTS
Line Regulation	$V_{IN}=15V$ to $25V$, $I_O=500mA$	$12mV = \pm 0.12\%$
Load Regulation	$V_{IN}=25V$, $I_O=50mA$ to $500mA$	$3.0mV = \pm 0.03\%$
Output Ripple	$V_{IN}=25V$, $I_O=500mA$	$120 mV_{pp}$
Short Circuit Current	$V_{IN}=25V$, $R_L=0.1$	$1.1A$
Efficiency	$V_{IN}=25V$, $I_O=500mA$	83.7%
Output Ripple With Optional Filter	$V_{IN}=25V$, $I_O=500mA$	$40 mV_{pp}$

KIA34063A/AF

(2) Voltage Inverting Converter

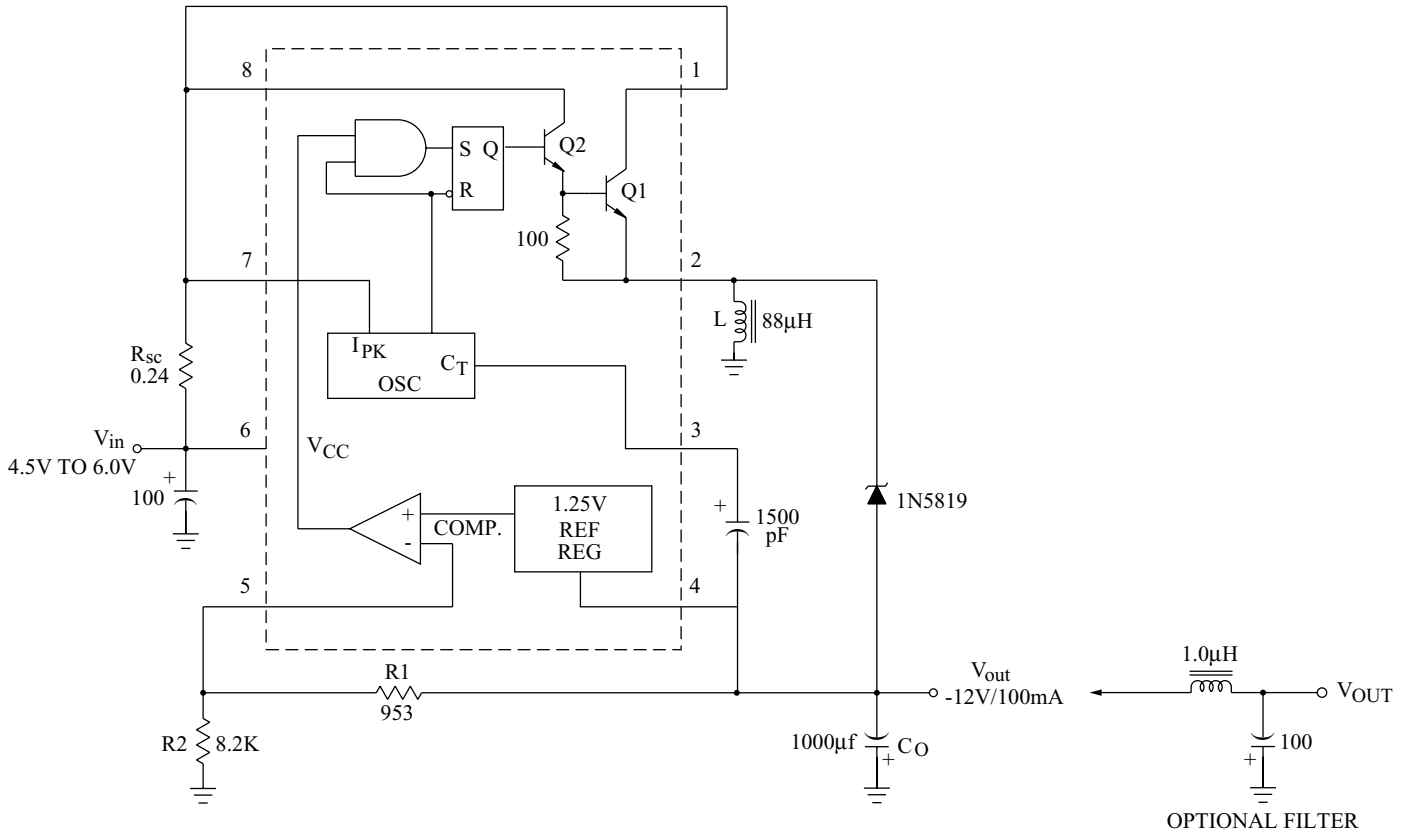

TEST	CONDITIONS	RESULTS
Line Regulation	$V_{IN}=4.5V$ to $6.0V$, $I_O=100mA$	$3.0mV = \pm 0.012\%$
Load Regulation	$V_{IN}=5.0V$, $I_O=10mA$ to $100mA$	$0.022V = \pm 0.09\%$
Output Ripple	$V_{IN}=5.0V$, $I_O=100mA$	$500 mV_{pp}$
Short Circuit Current	$V_{IN}=5.0V$, $R_L=0.1$	$910mA$
Efficiency	$V_{IN}=5.0V$, $I_O=100mA$	62.2%
Output Ripple With Optional Filter	$V_{IN}=5.0V$, $I_O=100mA$	$70 mV_{pp}$

KIA34063A/AF

$t_{on}, t_{off} - C_T$

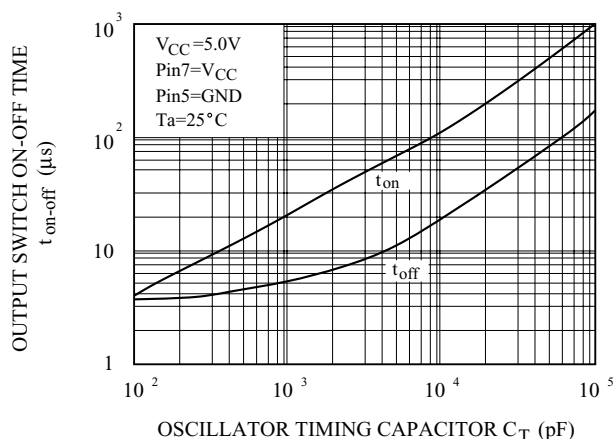

TIMING CAPACITOR WAVEFORM

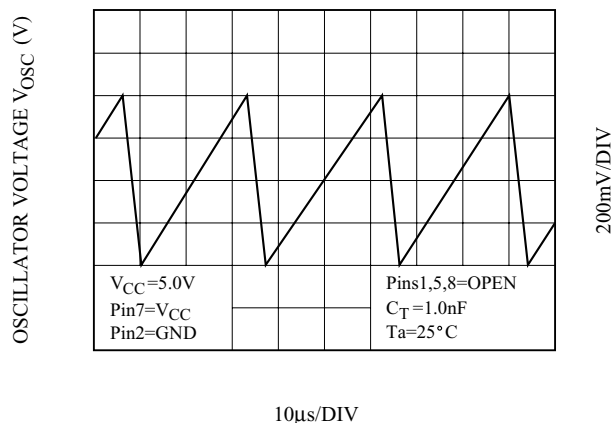

$V_{CE(sat)} - I_E$

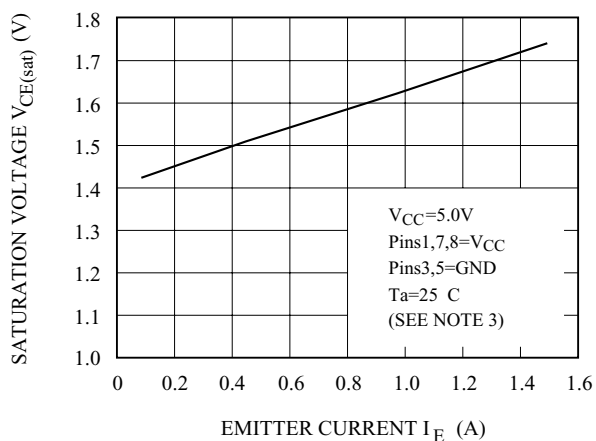

$V_{CE(sat)} - I_C$

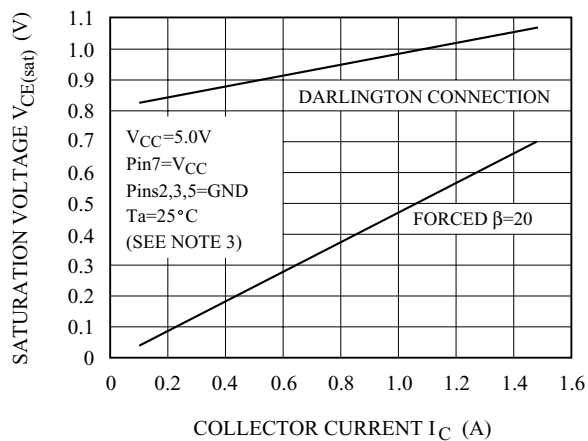

$V_{IPK(SENSE)} - T_a$

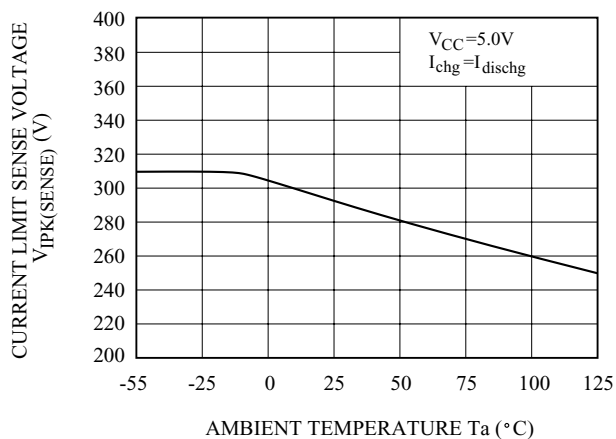

$I_{CC} - V_{CC}$

