

SBR12100

Schottky Barrier Rectifiers

Reverse Voltage 100V Forward Current 12A

FEATURES

- * Plastic package has Underwriters Laboratory Flammability Classification 94V-0
- * Low power loss, high efficiency
- * For use in low voltage high frequency inverters, free wheeling, and polarity protection applications
- * Guardring for over voltage protection
- * High temperature soldering guaranteed: 260°C/10 seconds at terminals

Mechanical Data

Case: JEDEC TO-277A,
 molded plastic over SKY body
 Terminals: Plated leads, solderable per
 MIL-STD-750, Method 2026
 Mounting Position: Any
 Weight: 0.108 g
 Handling precaution: None

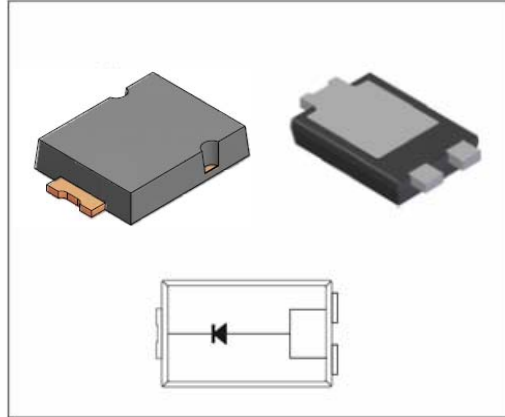

We declare that the material of product is
 Halogen free (green epoxy compound)

1. Electrical Characteristic

Maximum & Thermal Characteristics Ratings at 25°C ambient temperature unless otherwise specified.

Parameter Symbol	symbol	SBR12100L	Unit
device marking code		SBR12100L	
Maximum repetitive peak reverse voltage	V_{RRM}	100	V
Maximum RMS voltage	V_{RMS}	70	V
Maximum DC blocking voltage	V_{DC}	100	V
Maximum average forward rectified current at $T_c = 75^\circ\text{C}$	$I_F(AV)$	12.0	A
Peak forward surge current 8.3ms single half sine-wave superimposed on rated load (JEDEC Method)	I_{FSM}	200	A
Typical thermal resistance (Note 1)	R θ JC	8	$^\circ\text{C/W}$
	R θ JL	15	
	R θ JA	80	
Typical thermal resistance (Note 3)	R θ JA	135	$^\circ\text{C/W}$
Operating junction temperature range	T _J	-55 to +150	$^\circ\text{C}$
Storage temperature range	T _{STG}	-55 to +175	$^\circ\text{C}$

Electrical Characteristics Ratings at 25°C ambient temperature unless otherwise specified.

Parameter Symbol	symbol	SBR12100L	Unit
Maximum instantaneous forward voltage at 12A at 25°C	V_F	0.70	V
Maximum DC reverse current $T_j = 25^\circ\text{C}$ at rated DC blocking voltage $T_j = 125^\circ\text{C}$ (note2)	I _R	0.2 20	mA
Typical junction capacitance at 4.0V, 1MHz	C _J	500	PF

NOTES:

1. Polyimide PCB, 2oz. Copper. Cathode pad dimensions 18.8mm x 14.4mm. Anode pad dimensions 5.6mm x 14.4mm.
2. Short duration pulse test used to minimize self-heating effect.
3. FR-4 PCB, 2oz. Copper.

SBR12100

2. Ratings and Characteristic Curves (TA = 25°C unless otherwise noted)

Fig. 1 - Forward Current Derating

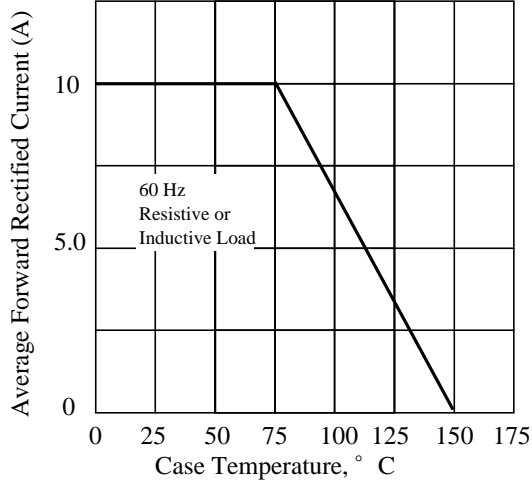

Fig. 2 - Maximum Non-repetitive Peak Forward Surge Current

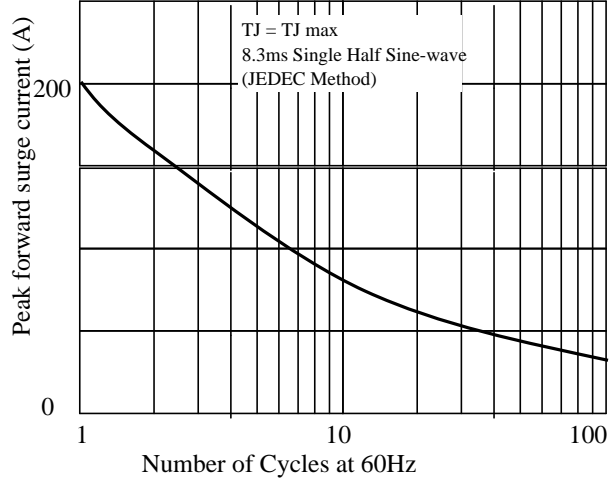

Fig 3. - Typical Instantaneous Forward Characteristics

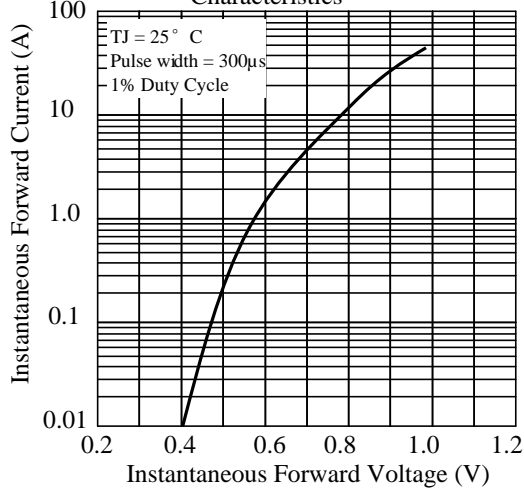

Fig 4. - Typical Reverse Characteristics

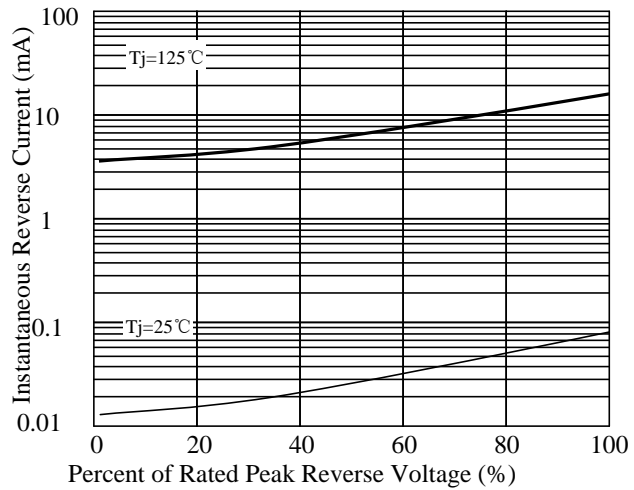

Fig 5. - typical transient thermal impedance (Note 3)

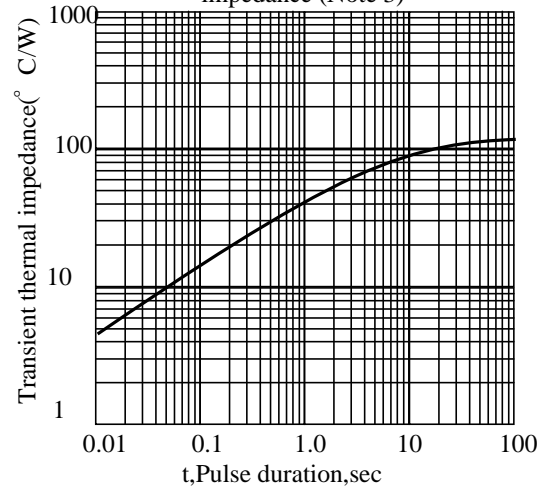
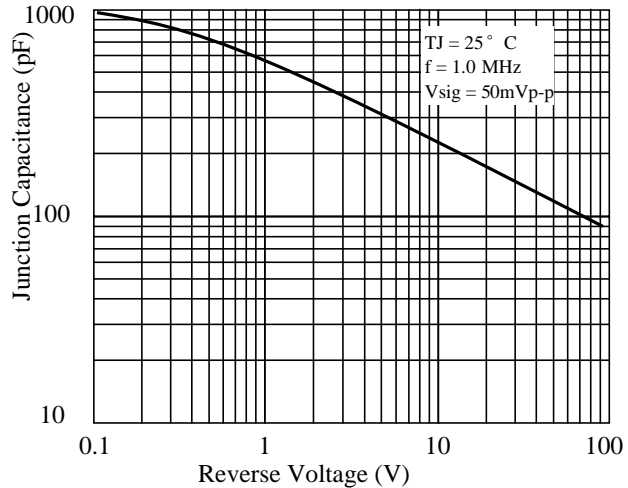

Fig 6. - Typical Junction Capacitance



SBR12100

3. dimension:

TO-277A

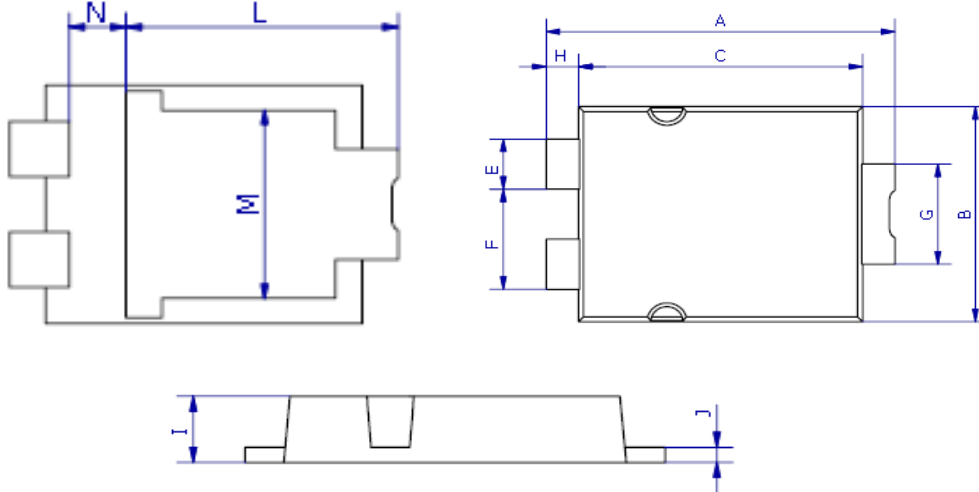

DIM	MILLIMETERS		INCHES	
	MIN	MAX	MIN	MAX
A	6.3	6.7	0.248	0.264
B	4.1	4.5	0.161	0.177
C	5.1	5.5	0.201	0.217
E	0.9	1.1	0.035	0.043
F	1.9	2.1	0.075	0.083
G	1.9	2.1	0.075	0.083
H	0.50	0.70	0.020	0.028
I	1.00	1.20	0.039	0.047
J	0.15	0.35	0.006	0.014
L	4.35	4.75	0.171	0.187
M	3.20	3.60	0.126	0.142
N	0.85	1.10	0.033	0.043

Mounting PAD layout

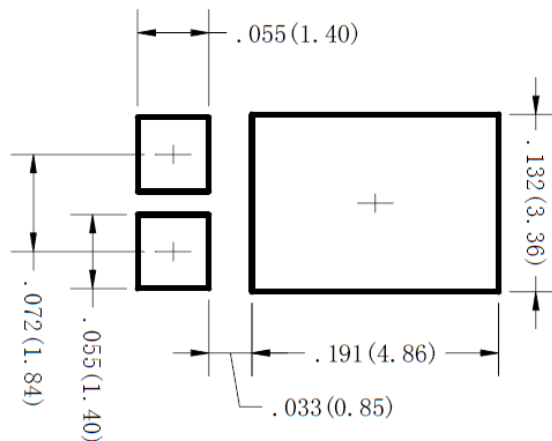

5.1 、 SMD Packing Reel Spec & Packing Quantity

5.1.1 Reel Packing

A. Reel Spec

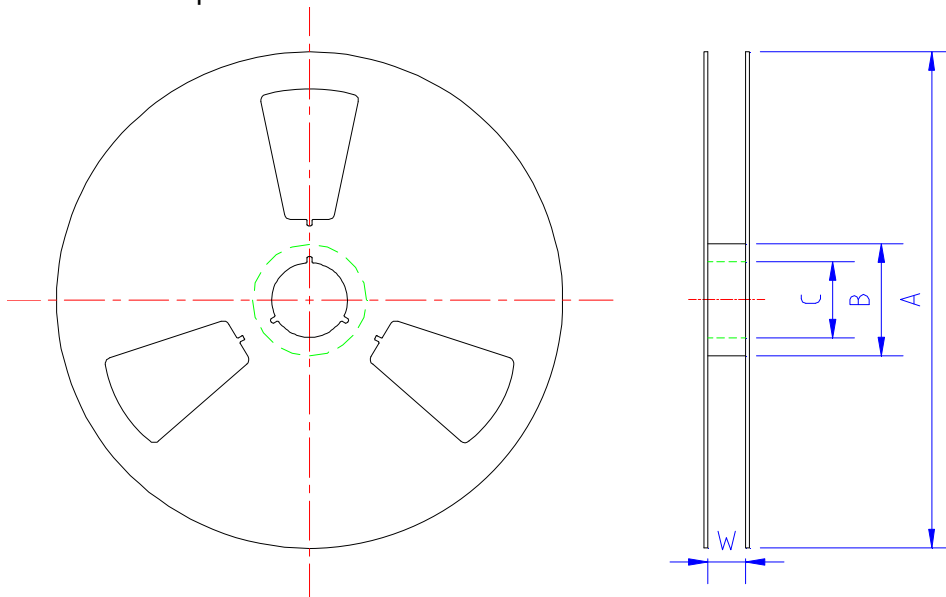

unit: mm

SPEC	A	B	C	W	Quantity/Reel
SMA-FL 7" reel	177.0±2.0	54.0±0.5	13.0±0.5	13.2±0.2	3K
TO277 13" reel	330.0±2.0	75.0±0.5	13.0±0.5	13.2±0.2	5K
SOD123FL 7" reel	177.0±2.0	50.0±0.5	13.0±0.5	9.4±1.5	3K
SOD323HE 7" reel	177.0±2.0	50.0±0.5	13.0±0.5	9.4±1.5	3K
SMB-FL 13" reel	330.0±2.0	75.0±0.5	13.0±0.5	13.2±0.2	5K

B. 13" reel packing box



unit: mm

size	A	B	C
	335±5.0	335±2.0	40±1.0

as per above packing

Spec	Q' ty/Box
TO277 13" reel	10K
SMB-FL 13" reel	10K

Title:
Power Diode SMD Package Packing Spec

DOC NO.: WI-258
DOC NO.: WI-258
Page: 3

C. 7" reel packing box

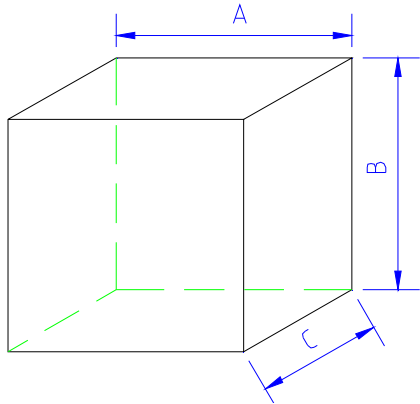

unit: mm

	A	B	C
SMA-FL SOD123FL SOD323HE	186±2.0	139±2.0	185±2.0

as per above packing

	Q' ty/Box
SMA-FL	30K
SOD123FL	30K
SOD323HE	30K

D. reel packing carton

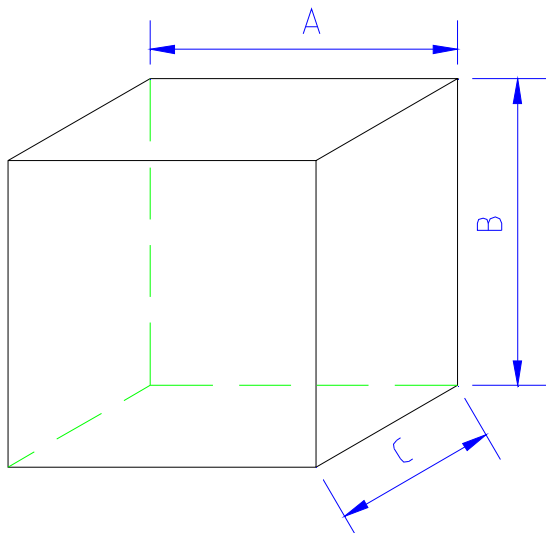

unit: mm

	A	B	C
size	350±2.0	340±2.0	350±2.0

as per above packing

Spec	Q' ty/Carton
TO277 13" reel	80K
SMB-FL 13" reel	80K

unit: mm

	A	B	C
SMA-FL SOD123FL SOD323HE	455±2.0	400±2.0	410±2.0

as per above packing

Spec	Q' ty/Carton
SMA-FL 7" reel	360K
SOD123-FL 7" reel	360K
SOD323HE 7" reel	360K

5.1.2 Tape Spec

A. Cover Tape



unit: mm

	A	B
SMA-FL SMB-FL TO277	9.5±0.10	0.062±0.007
SOD123FL SOD323HE	5.4±0.10	

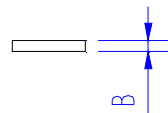

B. Carrier Tape

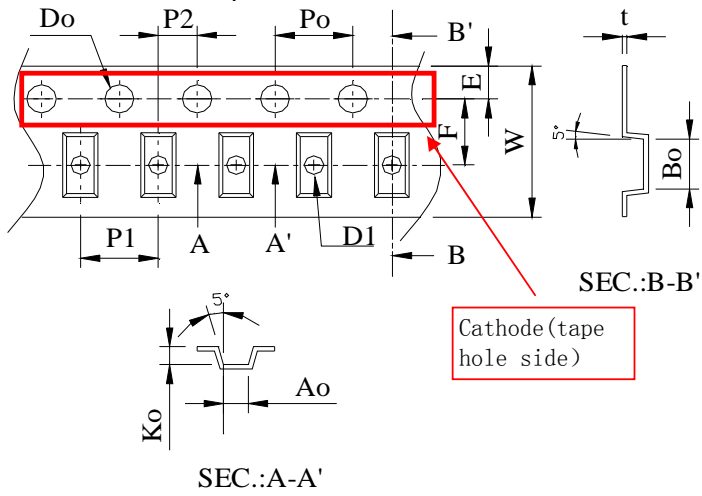

Item	SOD323HE	SOD123FL	SMA-FL	SMB-FL	TO277
W	8±0.3	8±0.3	12±0.3	12±0.3	12±0.3
P1	4±0.1	4±0.1	4±0.1	8±0.1	8±0.1
E	1.75±0.1	1.75±0.1	1.75±0.1	1.75±0.1	1.75±0.1
F	3.5±0.05	3.5±0.05	5.5±0.05	5.5±0.05	5.5±0.05
D0	1.55±0.05	1.55±0.05	1.55±0.05	1.55±0.05	1.55±0.05
D1	1.1±0.1	1.1±0.1	1.5±0.1	1.55±0.05	1.5±0.1
P0	4±0.1	4±0.1	4±0.1	4±0.1	4±0.1
P2	2±0.05	2±0.05	2±0.05	2±0.05	2±0.05
10P0	40±0.2	40±0.2	40±0.2	40±0.2	40±0.2
A0	1.45±0.1	1.95±0.1	2.83±0.1	3.8±0.1	4.3±0.1
B0	2.75±0.1	3.95±0.1	4.75±0.1	5.75±0.1	6.8±0.1
K0	0.80±0.1	1.30±0.1	1.42±0.1	1.4±0.1	1.35±0.1
T	0.25±0.05	0.25±0.05	0.25±0.05	0.25±0.05	0.25±0.05

5.2、SMD Power Diode General Packing Spec

A. 7" reel all labels will be at cathode side of reel ;

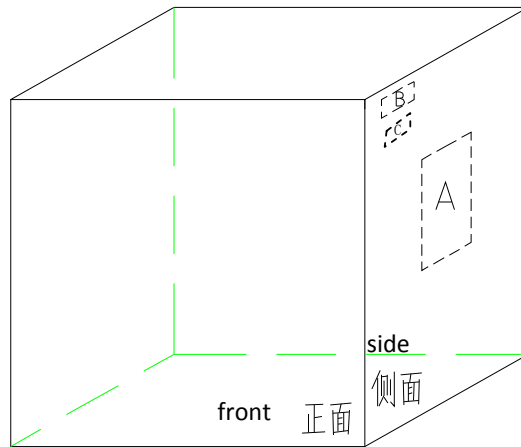
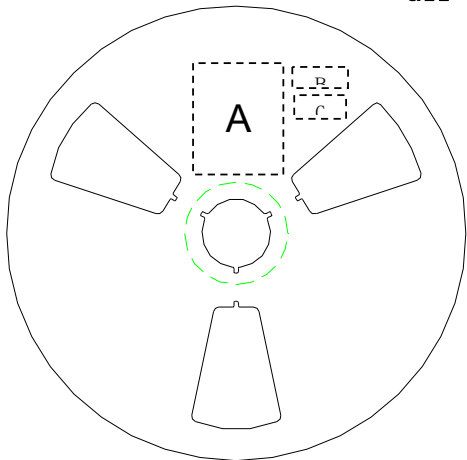

A:LRC label;

B:Environment Label C:Halide free label

B. 13" reel

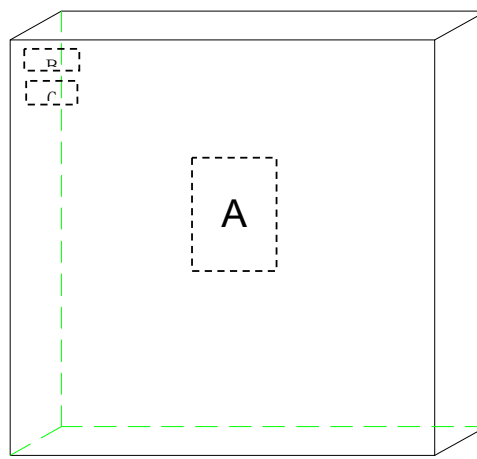
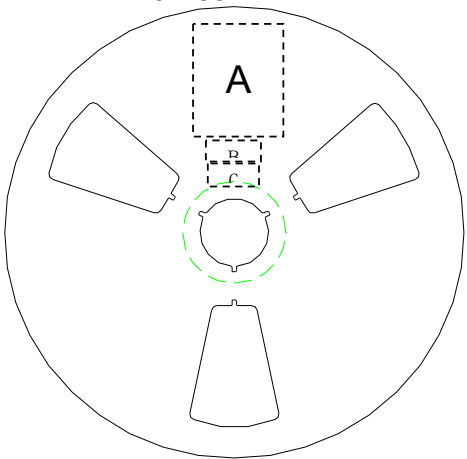

A:LRC label;

B:Environment Labe C:Halide free label

C. Tape lead: face anode side of the reel, upper side is the tape lead position. All labels are at cathode side of the reel.



标题: Power Diode SMD Package Packing Spec	DOC NO.: WI-258
	Version: 5 Modification: 0
	Page: 6

C. Label Content :
LRC Label

P/N → (1P) LPN: **SM140A**
 Lot No. → (1T) LOT: **140106049X**
 Date code → (9D) DTE: **1403**
 Quantity → (Q) QTY: **10000**

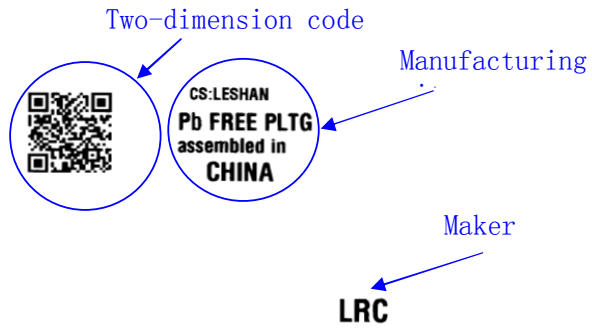

lot: 140106049X: 140106---2014/1/6; 049----lot number:49; X: product code

Environment Label



Halide-free Label



SBR12100

4. Update Record

版次	更新记录	更新作者	更新日期
1	第一版	周杰	2014-3-18
2	标注外形尺寸公差	周杰	2014-6-9