

FEATURES

- ◆ RoHS compliant
- ◆ Efficiency up to 85%
- ◆ SIP Package
- ◆ Wide temperature performance at full 2 Watt load, -40°C to 85 °C
- ◆ UL 94V-0 package material
- ◆ No heatsink required
- ◆ Low ripple and good EMC features
- ◆ Industry standard pinout
- ◆ Power sharing on output
- ◆ 1KVDC isolation
- ◆ Continuous Short Circuit Protection
- ◆ Internal SMD construction
- ◆ No external components required
- ◆ Good dynamic feature

MODEL SELECTION

2D^①05^②05^③05^④X^⑤S^⑥

- ① Product Series
- ② Input Voltage
- ③ Output Voltage1
- ④ Output Voltage2
- ⑤ Fixed Input
- ⑥ SIP Package

APPLICATIONS

The 2D-XS series are specially designed for applications where a group of polar power supplies are isolated from the input power supply in a distributed power supply system on a circuit board.

These products apply to:

- 1) where the voltage of the input power supply is fixed (voltage variation $\leq \pm 10\%$);
- 2) where isolation is necessary between input and output (isolation voltage $\leq 1000\text{VDC}$);
- 3) where the regulation of the output voltage and the output ripple noise are not demanded.

Such as: purely digital circuits, ordinary low frequency analog circuits, and 1GBT power device driving circuits.



SELECTION GUIDE

Order code	Input		Output			Efficiency (% Typ)	Switching Frequency (KHz Typ)
	Voltage (VDC)		Voltage (VDC)	Current			
	Nominal	Range		Max	Min		
2D050505XS	5	4.5-5.5	5	200	20	80	84
2D050909XS	5	4.5-5.5	9	111	12	82	81
2D051212XS	5	4.5-5.5	12	83	9	82	82
2D051515XS	5	4.5-5.5	15	67	7	83	83
2D120505XS	12	10.8-13	5	200	20	80	180
2D120909XS	12	10.8-13	9	111	12	83	150
2D121212XS	12	10.8-13	12	83	9	85	84
2D121515XS	12	10.8-13	15	67	7	83	83
2D240505XS	24	21.6-26	5	200	20	81	82
2D240909XS	24	21.6-26	9	111	12	82	83
2D241212XS	24	21.6-26	12	83	9	84	83
2D241515XS	24	21.6-26	15	67	7	84	80

ISOLATION SPECIFICATIONS

Parameter	Test conditions	Min.	Typ.	Max.	Unit
Isolation test voltage	Flash tested for 1 minute and 1mA max(Vin/Vout)	1000			VDC
	Flash tested for 1 minute and 1mA max(V01/V02)	1000			VDC
Isolation resistance	Test at Viso=500VDC(Vin/Vout)	1000			MΩ
	Test at Viso=500VDC(V01/V02)	1000			MΩ
Isolation capacitance	(Vin/Vout)		90		PF
	(V01/V02)		90		PF

OUTPUT SPECIFICATIONS

Parameter	Test conditions	Min	Typ.	Max	Unit
Output power				2	W
Line regulation	For Vin change of $\pm 1\%$			± 1.2	%
Load regulation	10% to 100% full load(5V output)		12.8	15	
	10% to 100% full load(9V output)		8.3	10	
	10% to 100% full load(12V output)		6.8	10	
	10% to 100% full load(15V output)		6.3	10	
Output voltage accuracy		See tolerance envelope graph			
Temperature drift	100% full load		0.03		%/°C
Output Ripple&Noise*	20MHz Bandwidth		100	150	MV p-p
Switching frequency	Full load, nominal input		70		Khz

* Test ripple and noise by "parallel cable" method. See detailed operation instructions at Testing of Power Converter section, application notes.

COMMON SPECIFICATIONS					
Parameter	Conditions	Min.	Typ.	Max.	Units
Storage humidity range				95	%
Operating temperature		-40		85	°C
Storage temperature		-55		125	
Lead temperature	1.5mm from case for 10 seconds		300		
Temp.rise at full load			15	25	
Cooling	Free air convection				
Case material	Plastic(UL94-V0)				
Short circuit protection*	Continuous				
MTBF		3500		1	s
Weight			2.8		g

*Supply voltage must be discontinued at the end of short circuit duration.

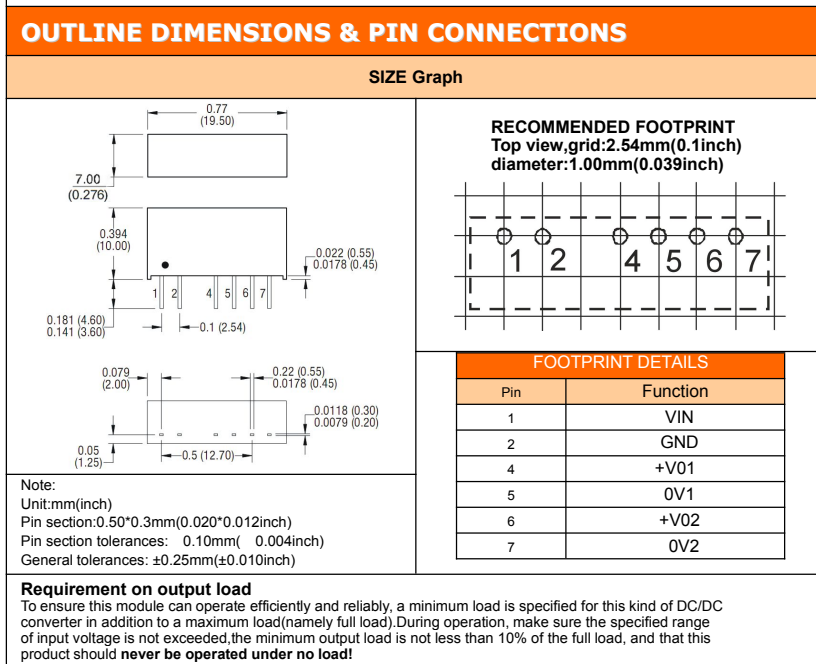
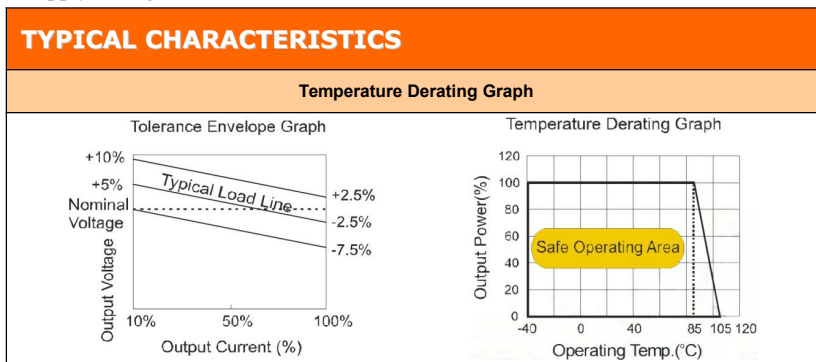

Filtering

To get the input/output ripple,an "LC"filtering network may be connected to the input and output ends of the DC/DC converter.Which may produce a more significant filtering effect.It should also be noted that the inductance and the frequency of the "LC"filtering network should be staggered with the DC/DC frequency to avoid mutual interference see (Figure 1).

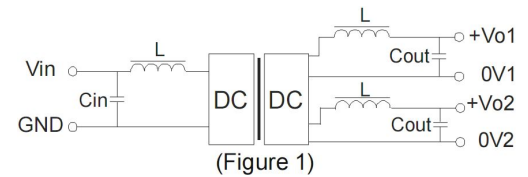

In some circuits which are sensitive to noise and ripple a filtering capacitor may be added to the DC/DC output end and input end to reduce the noise and ripple. However, the capacitance of the output filter capacitor must be proper. If the capacitance is too big, a startup problem might arise. For every channel of output, provided the safe and reliable operation is ensured, the greatest capacitance of its filter capacitor sees (Table 1).

EXTERNAL CAPACITOR TABLE (TABLE 1)

Vin (VDC)	Cin (µF)	Vout (VDC)	Cout (µF)
5	47	5	4.7
12	2.2	9	2.2
24	1.0	12	1.0
--	--	15	0.47

It's not recommend to connect any external capacitor in the application field with less than 0.5 watt output.

Output Voltage Regulation and Over-voltage Protection Circuit

The simplest device for output voltage regulation, over-voltage and over-current protection is a linear voltage regulator with overheat protection that is connected to the input or output end in series (Figure 2).

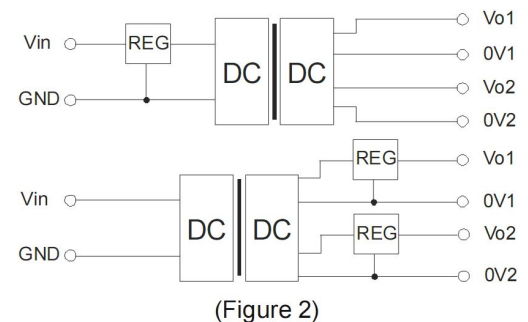

When the environment temperature is higher than 71°C, the product output power should be less than 60% of the rated power.

No parallel connection or plug and play.

RoHS COMPLIANT INFORMATION

This series is compatible with RoHS soldering systems with a peak wave solder temperature of 300° C for 10 seconds.
The pin termination finish on the SIP package type is Tin Plate, Hot Dipped over Matte Tin with Nickel Preplate. The DIP types are Matte Tin over Nickel Preplate. Both types in this series are backward compatible with Sn/Pb soldering systems.

REACH COMPLIANT INFORMATION

This series has proven that this product does not contain harmful chemicals, it also has harmful chemical substances through the registration, inspection and approval.