

## 300mA, Micropower, Dual Channel VLDO Linear Regulator

**UM4750S-xx SOT23-6**

**UM4750DA-xx DFN6 2.0×2.0**

**UM4750DB-xx DFN8 3.0×3.0**

### General Description

The UM4750 series are dual channel VLDO (very low dropout) linear regulators designed for low power portable applications. The range of output voltage is from 1.2V to 5.0V while operated from 2.5V to 5.5V input. Typical output noise is only  $200\mu\text{V}_{\text{RMS}}$  and maximum dropout is just 200mV at the load current of 100mA.

The UM4750 series offer high output voltage accuracy, excellent transient response, stability with ultra low ESR ceramic capacitors as small as  $1\mu\text{F}$ , thermal overload protection and output current limiting.

The UM4750S-xx series are available in a low profile SOT23-6 package, the UM4750DA-xx series are available in a low profile DFN6 2.0×2.0 package, and UM4750DB-xx series are available in a low profile DFN8 3.0×3.0 package.

### Applications

- Bluetooth/802.11 Cards
- PDAs and Notebook Computers
- Portable Instruments and Battery-Powered Systems
- Cellular Phones

### Features

- Very Low Dropout: 200mV(max) at 100mA
- Maximum Input Voltage: 5.5V
- Low Noise:  $200\mu\text{V}_{\text{RMS}}$  (10Hz to 100kHz)
- Fast Transient Response
- Dual LDO Outputs(300mA/300mA)
- Output Current Limit
- Stable with  $1\mu\text{F}$  Output Capacitor
- Thermal Overload Protection
- Low Profile SOT23-6, 6-Lead DFN2.0×2.0 and 8-Lead DFN 3.0×3.0 Packages

### Pin Configurations

### Top View

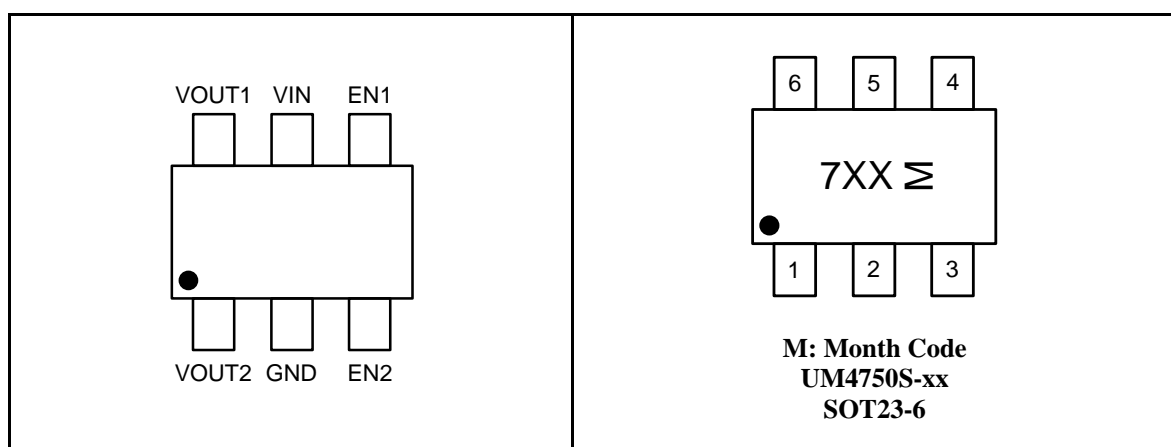

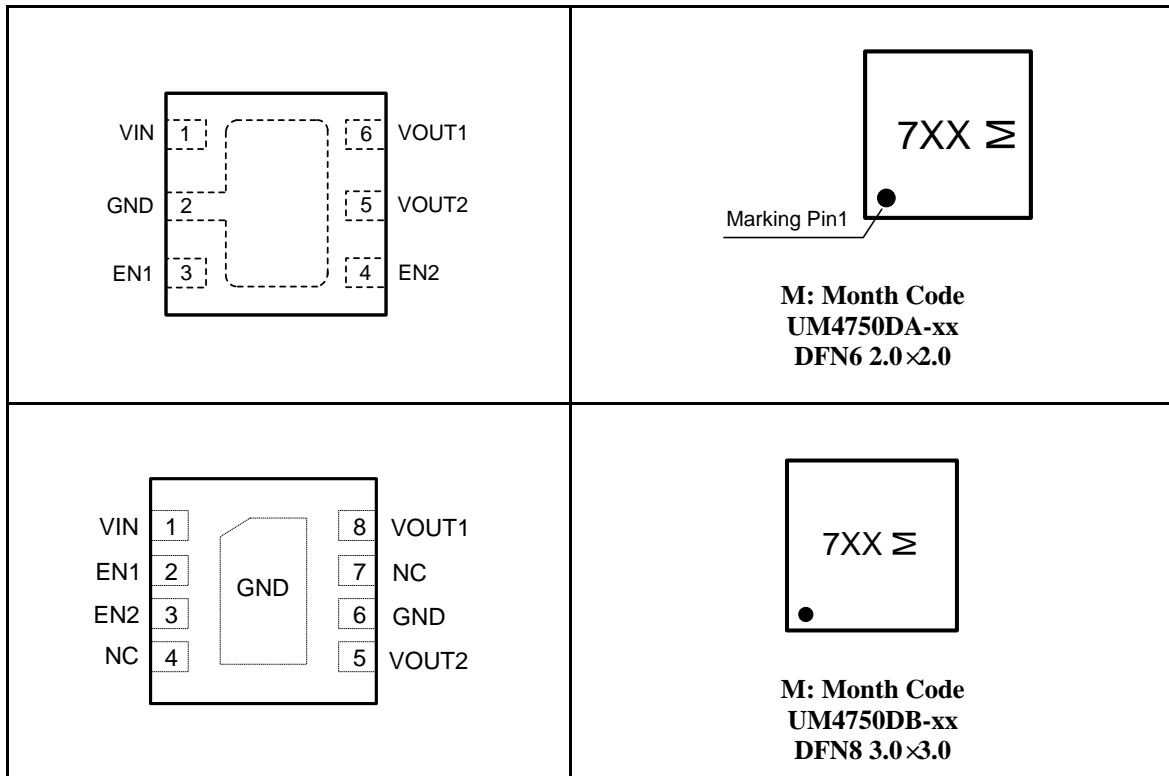

### Pin Description

Pin Number			Symbol	Function
UM4750S-xx	UM4750DA-xx	UM4750DB-xx		
1	5	5	VOUT2	Channel2 output voltage
2	2	6	GND	Ground
3	4	3	EN2	Enable2 Input, Active High
4	3	2	EN1	Enable1 Input, Active High
5	1	1	VIN	Power Supply
6	6	8	VOUT1	Channel1 output voltage
-	-	4,7	NC	No connection

### Naming Information

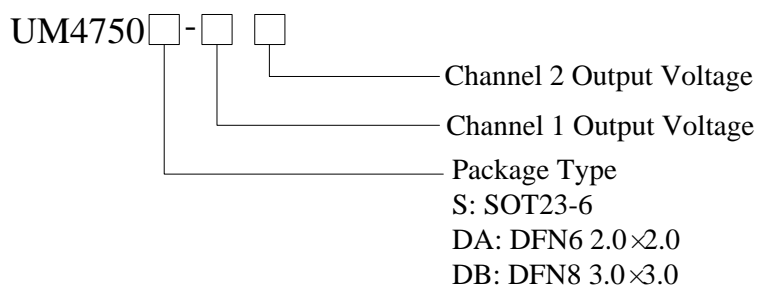

**Available Voltage Version**

Code	Voltage	Code	Voltage	Code	Voltage	Code	Voltage
A	5	F	4.2	L	3.3	R	1.8
B	4.8	G	4	M	3	S	1.5
C	4.7	H	3.8	N	2.8	T	1.3
D	4.5	J	3.6	P	2.7	U	1.2
E	4.3	K	3.5	Q	2.5		

**Ordering Information**

Part Number	Packaging Type	Marking Code	Shipping Qty
UM4750S-RN	SOT23-6	UDS	3000pcs/7Inch Tape & Reel
UM4750S-RL		UDT	
UM4750S-NR		UGS	
UM4750S-xx		7XX	
UM4750DA-xx	DFN6 2.0×2.0	7XX	
UM4750DB-xx	DFN8 3.0×3.0	7XX	

**Absolute Maximum Ratings (Note 1)**

Symbol	Parameter	Value	Unit
$V_{IN}$	Supply Voltage on IN Pin	-0.3 to +6.5	V
$V_{OUT}$	Voltage on OUT Pin	-0.3 to +7.5	V
$T_J$	Operating Junction Temperature (Notes 2, 3)	-40 to +125	°C
$T_{STG}$	Storage Temperature Range	-65 to +150	°C
$T_L$	Lead Temperature for Soldering 10 seconds	+300	°C
	ESD Susceptibility HBM	2000	V
$P_D$	Power Dissipation at $T_A = 25\text{ °C}$	SOT23-6	0.5
		DFN6 2.0×2.0	0.7
		DFN8 3.0×3.0	0.9

Note 1: Absolute Maximum Ratings are those values beyond which the life of a device may be impaired.

Note 2: The device is guaranteed to meet performance specifications from 0°C to 70°C. Specifications over the -40°C to 125°C operating junction temperature range are guaranteed by design, characterization and correlation with statistical process controls.

Note 3: This IC includes over temperature protection circuit inside that is intended to protect the device during momentary overload conditions. Over temperature protection trip point is around 160°C. Continuous operation above the specified maximum operating junction temperature may impair device reliability.

## Recommended Operating Conditions (Note 4)

Supply Input Voltage	2.5V to 5.5V
Enable Input Voltage	0V to 5.5V
Junction Temperature Range	-40 °C to 125 °C
Ambient Temperature Range	-40 °C to 85 °C

Note 4: The device is not guaranteed to function outside its operating conditions.

## Internal Block Diagram

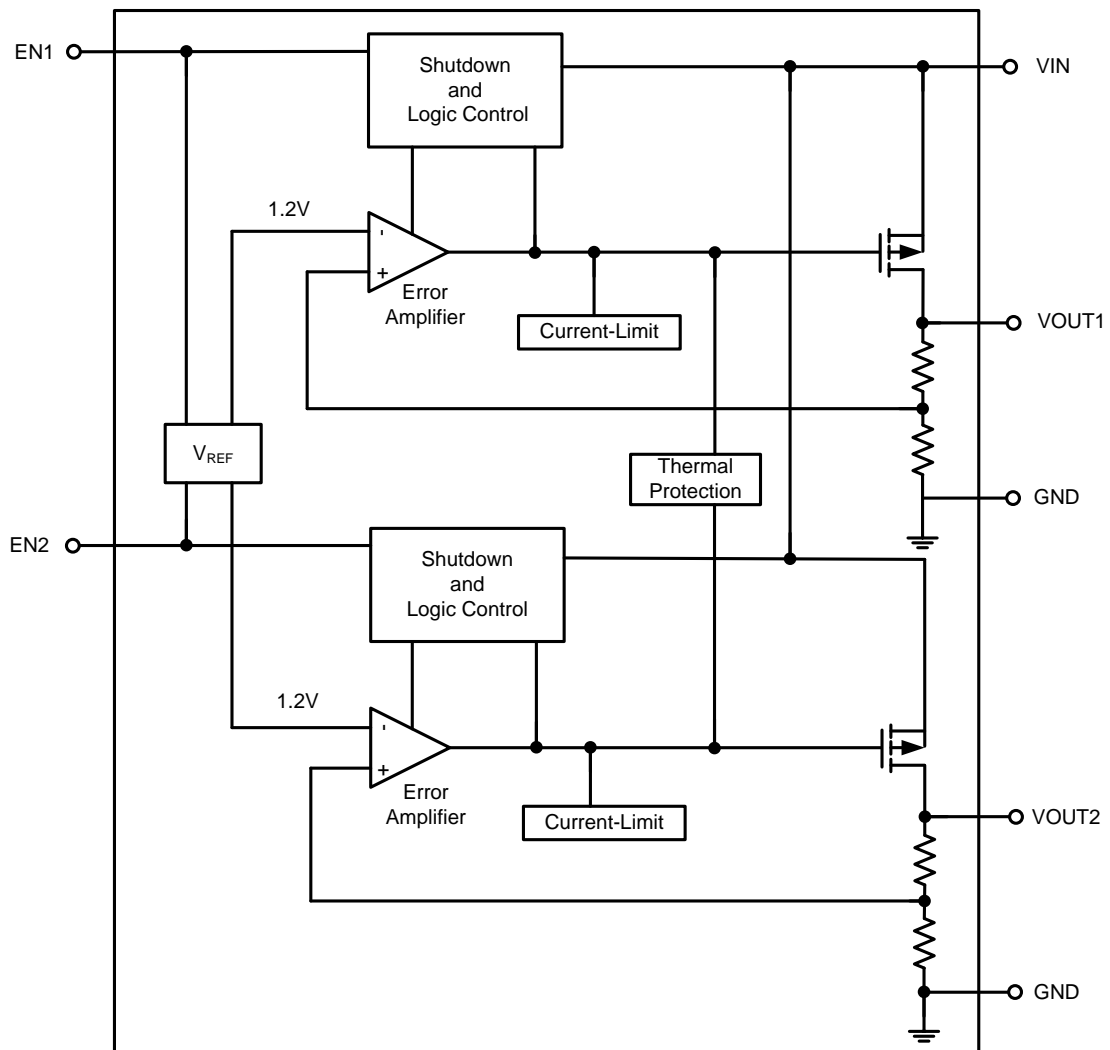

**Electrical Characteristics**

$V_{CC}=+5V \pm 10\%$ ,  $C_{IN}=1\mu F$ ,  $C_{OUT1}=C_{OUT2}=1\mu F$ ,  $T_A=-40^\circ C$  to  $+85^\circ C$ . Typical conditions are at  $V_{CC}=5V$ ,  $T_A=25^\circ C$ .

Parameter	Symbol	Test Conditions	Min	Typ	Max	Unit
Input Voltage Range	$V_{IN}$		2.5		5.5	V
Output Voltage Range	$V_{OUT}$		1.2		5.0	V
Operating Quiescent Current	$I_Q$	$I_{OUT}=0mA$		110	190	$\mu A$
Shut Down Current	$I_{Q\_SD}$	$EN1=EN2=GND$			2	$\mu A$
EN Input Current	$I_{EN}$	$EN=V_{IN}$ or GND			1	$\mu A$
Output Current	$I_{OUT}$		300			mA
Output Voltage Accuracy		$I_{OUT}=10mA$	-2		2	%
Dropout Voltage	$\Delta V_{DO}$	$I_{OUT}=100mA$ , $V_{OUT}>2.8V$		100	200	mV
Output Current Limit	$I_{LIMIT}$		330	450	700	mA
Startup Time Response	t	$R_L=68\Omega$ , $C_{OUT}=1\mu F$		20		$\mu s$
EN Input Low Voltage	$V_{IL}$	$V_{IN}=2.5V$ to $5.5V$			$0.3 \times V_{IN}$	V
EN Input High Voltage	$V_{IH}$		$0.7 \times V_{IN}$			V
Output Voltage TC				100		ppm/ $^\circ C$
Thermal-Shutdown Temperature	$T_{SHDN}$			150		$^\circ C$
Thermal-Shutdown Hysteresis	$\Delta T_{SHDN}$			30		$^\circ C$
Line Regulation	LNR	$1.5 < V_{OUT} \leq 4V$ $V_{OUT} + 1V \leq V_{IN} \leq 5.5V$ , $I_{OUT} = 10mA$			0.3	%/ $V$
		$4V < V_{OUT} \leq 5V$ or $1.2V \leq V_{OUT} \leq 1.5V$ $V_{OUT} + 1V \leq V_{IN} \leq 5.5V$ and $V_{IN} > 2.5V$ , $I_{OUT} = 10mA$			0.6	
Load Regulation	LDR	$V_{OUT} \leq 4V$ $1mA \leq I_{OUT} \leq 300mA$			0.6	%
		$4V < V_{OUT} \leq 5V$ $1mA \leq I_{OUT} \leq 300mA$			0.8	
Output Voltage Noise		10Hz to 100KHz $C_{IN}=1\mu F$ , $I_{OUT}=10mA$		200		$\mu V_{RMS}$
Power Supply Ripple Rejection	PSRR	$V_{IN}=V_{OUT}+1V$ $I_{OUT}=100mA$	F=100Hz	60		dB
			F=1KHz	45		
ESD Rating		Human Body Mode	2			KV

## Typical Performance Characteristics

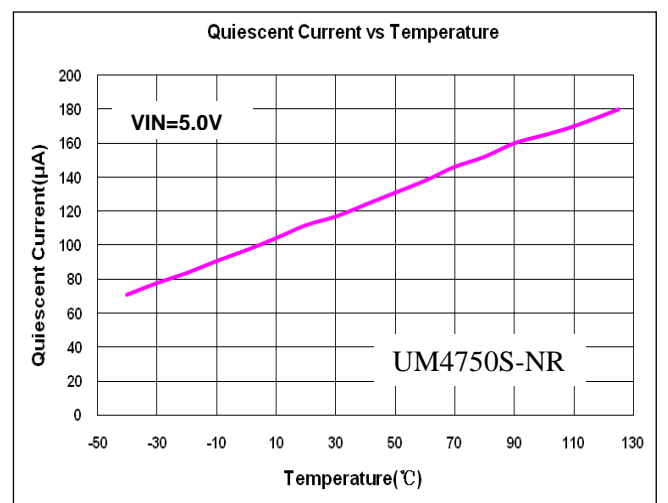
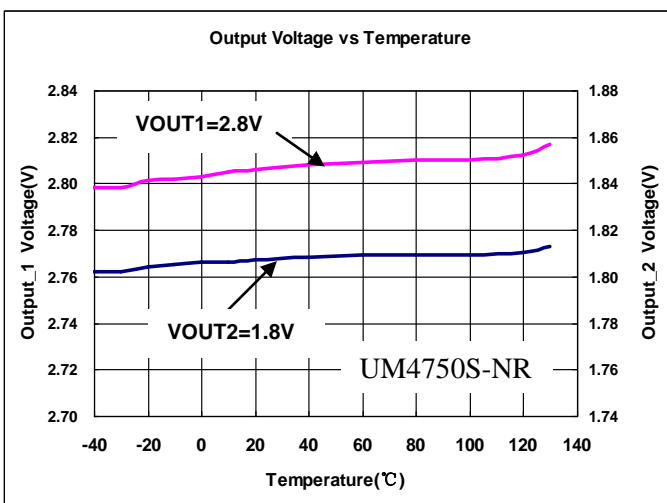
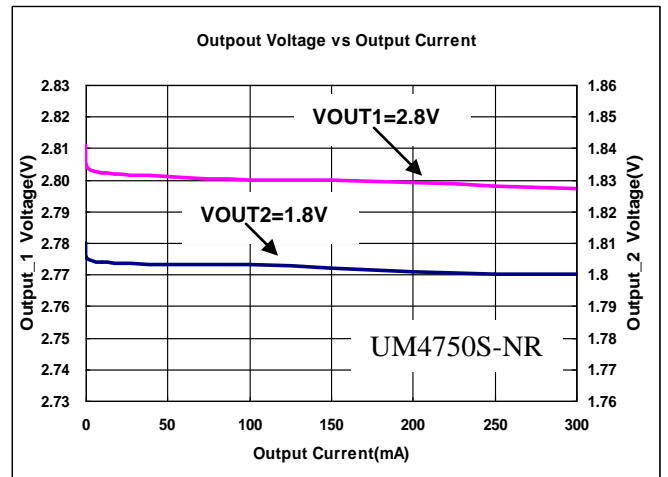
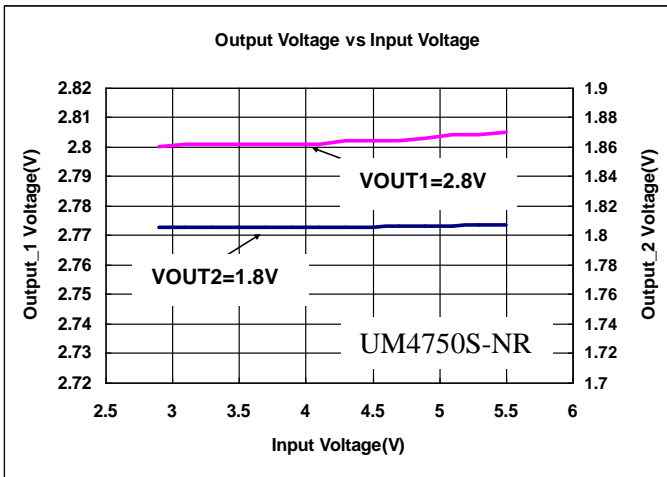
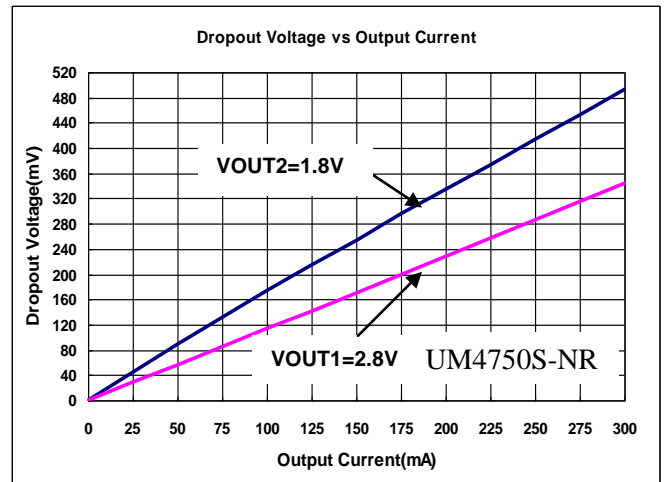
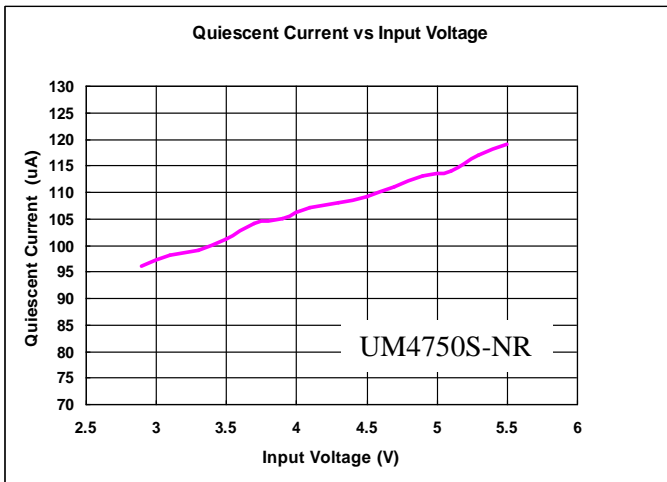

**Typical Performance Characteristics (Continued)**

**Line Transient Response**

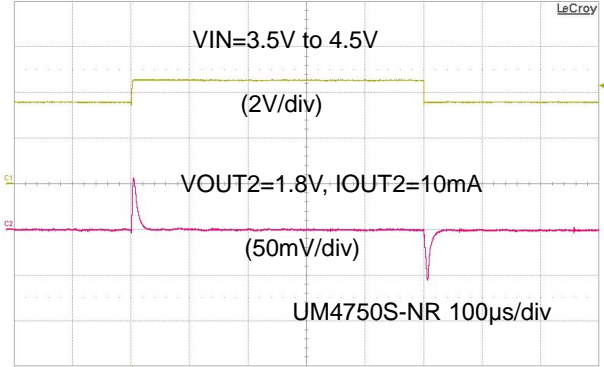
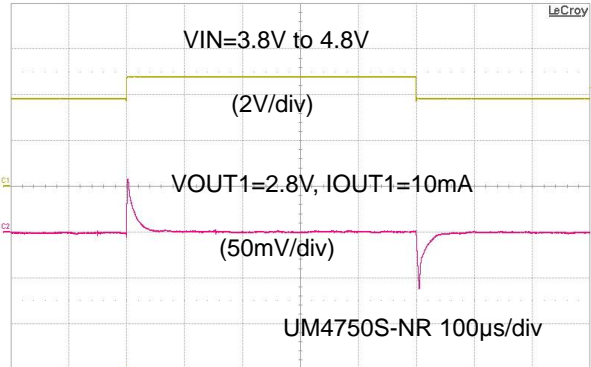

**Load Transient Response**

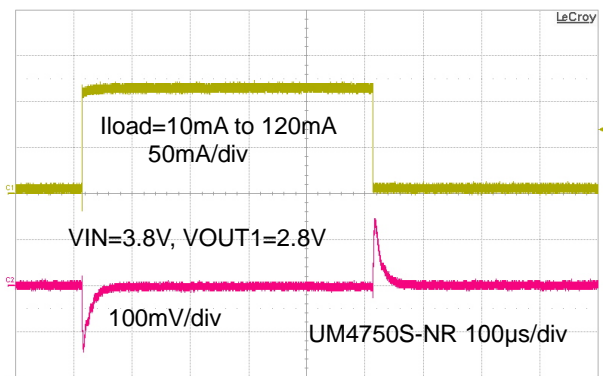
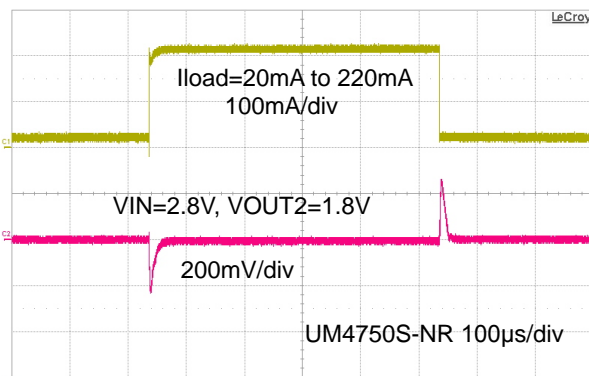

## Typical Application Circuit

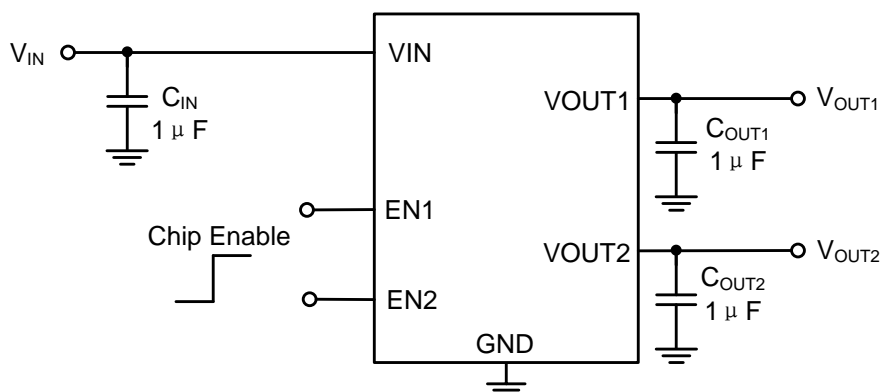

## Pin Function

**VIN** : Unregulated input supply. A small 1.0 $\mu$ F capacitor should be connected from VIN to GND.  
**GND** : Ground and Heat Sink. Solder to a ground plane or large pad to maximize heat dissipation.  
**EN**: Enable, Active High. This pin is used to put the UM4750 into shutdown. The EN pin cannot be left floating and must be tied to the input pin if not used.  
**VOUT** : Regulated Voltage Output.

## Applications Information

The UM4750 series are 300mA very low dropout regulators with micropower quiescent current and shutdown. The maximum dropout is only 200mV at the load current of 100mA. Output voltage noise is as low as 200 $\mu$ V<sub>RMS</sub> over a 10Hz to 100kHz bandwidth. In addition to the low quiescent current, the UM4750 regulators incorporate several protection features which make them ideal for use in battery-powered systems. Devices include current limit and thermal overload protection.

## Output Capacitance and Transient Response

The UM4750 regulators are designed to be stable with a wide range of output capacitors. The ESR of the output capacitor affects stability, most notably with small capacitors. A minimum output capacitor of 1 $\mu$ F with an ESR of 0.3 $\Omega$  or less is recommended to ensure stability. The UM4750 series are micropower devices and output transient response will be a function of output capacitance. Larger values of output capacitance decrease the peak deviations and provide improved transient response for larger load current changes. Extra consideration must be given to the use of ceramic capacitors. The X5R and X7R dielectrics result in more stable characteristics and are more suitable for use as the output capacitor. The X7R type has better stability across temperature, while the X5R is less expensive and is available in higher values.

## Board Layout Recommendations to Improve PSRR and Noise Performance

To improve AC performance such as PSRR, output noise, and transient response, it is recommended that the board be designed with separate ground planes for Vin and Vout, with each ground plane connected only at the GND pin of the device. In addition, the ground connection for the output capacitor should connect directly to the GND pin of the device. High ESR capacitors may degrade PSRR.



### Internal Current Limit

The UM4750 internal current limits help protect the regulator during fault conditions. During current limit, the output sources a fixed amount of current that is largely independent of output voltage. For reliable operation, the device should not be operated in a limit state for extended periods of time.

The PMOS pass element in the UM4750 has a built-in body diode that conducts current when the voltage at OUT exceeds the voltage at IN. This current is not limited, so if extended reverse voltage operation is anticipated, external limiting to 5% of rated output current may be appropriate.

### Dropout Voltage

The UM4750 use a PMOS pass transistor to achieve low dropout. When  $(V_{in}-V_{out})$  is less than the dropout voltage, the PMOS pass device is in its linear region of operation and the input-to-output resistance is the  $R_{ds}$  of the PMOS pass element.  $V_{drop}$  approximately scales with output current because the PMOS device behaves like a resistor in dropout.

### Thermal Protection

Thermal protection disables the output when the junction temperature rises to approximately  $+150^{\circ}\text{C}$  allowing the device to cool. When the junction temperature cools to approximately  $+120^{\circ}\text{C}$  the output circuit is again enabled. Depending on power dissipation, thermal resistance, and ambient temperature, the thermal protection circuit may cycle on and off. This cycling limits the dissipation of the regulator, protecting it from damage due to overheating.

### Thermal Considerations

Thermal protection limits power dissipation in UM4750. When the operation junction temperature exceeds  $150^{\circ}\text{C}$ , the OTP circuit starts the thermal shutdown function and turns the pass element off. The pass element turns on again after the junction temperature cools by  $25^{\circ}\text{C}$ . For continuous operation, do not exceed absolute maximum operation junction temperature  $125^{\circ}\text{C}$ . The power dissipation definition in device is:

$$P_D = (V_{IN} - V_{OUT1}) \times I_{OUT1} + (V_{IN} - V_{OUT2}) \times I_{OUT2} + V_{IN} \times I_Q$$

The maximum power dissipation depends on the thermal resistance of IC package, PCB layout, the rate of surroundings airflow and temperature difference between junctions to ambient. The recommended maximum power dissipation of SOT23-6, DFN6 2.0×2.0 and DFN8 3.0×3.0 packages for  $25^{\circ}\text{C}$  ambient temperature are 0.5W, 0.7W and 0.9W.

## Package Information

### UM4750S-xx SOT23-6

#### Outline Drawing

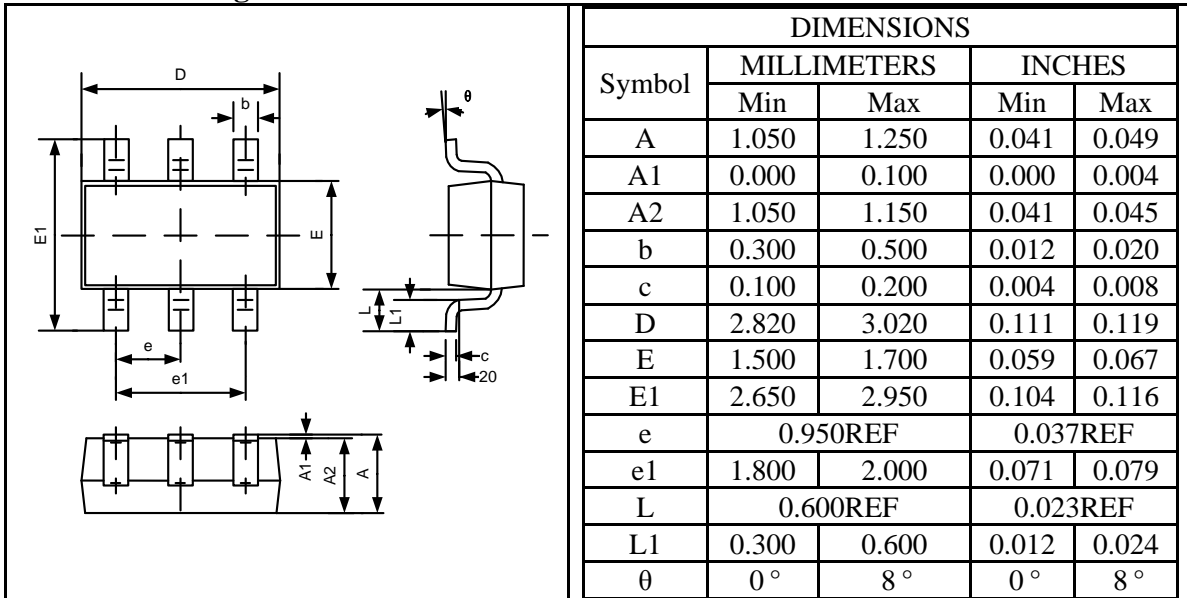

#### Land Pattern

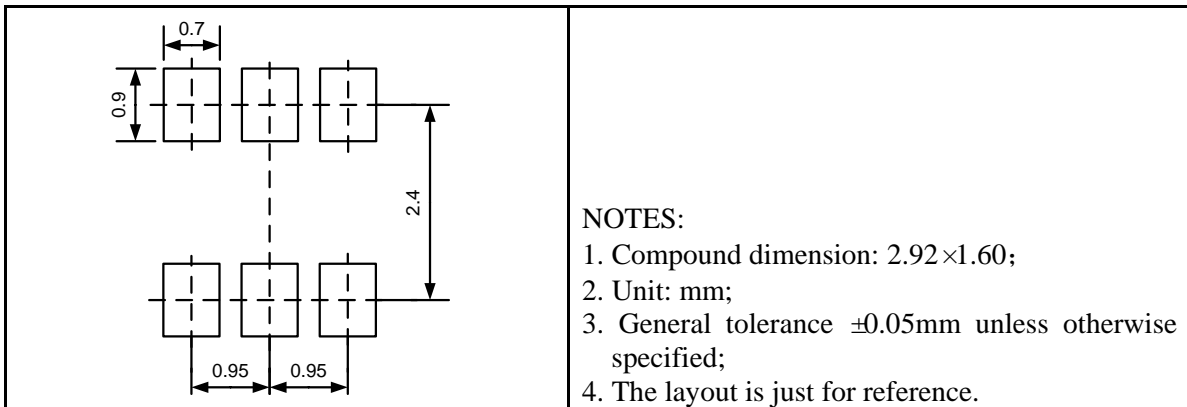

#### Tape and Reel Orientation

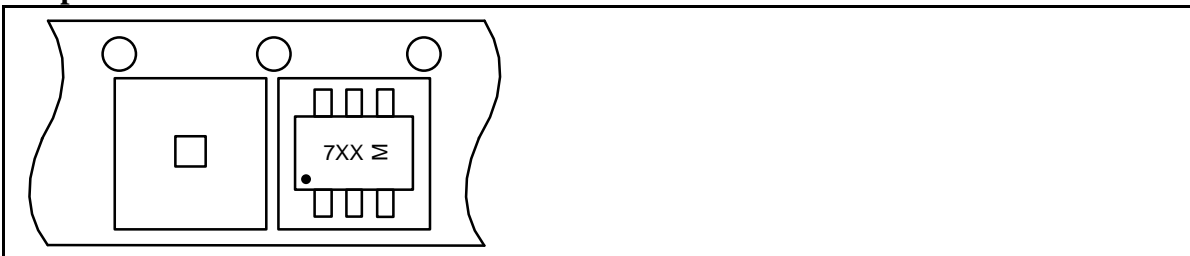

## UM4750DA-xx DFN6 2.0×2.0

### Outline Drawing

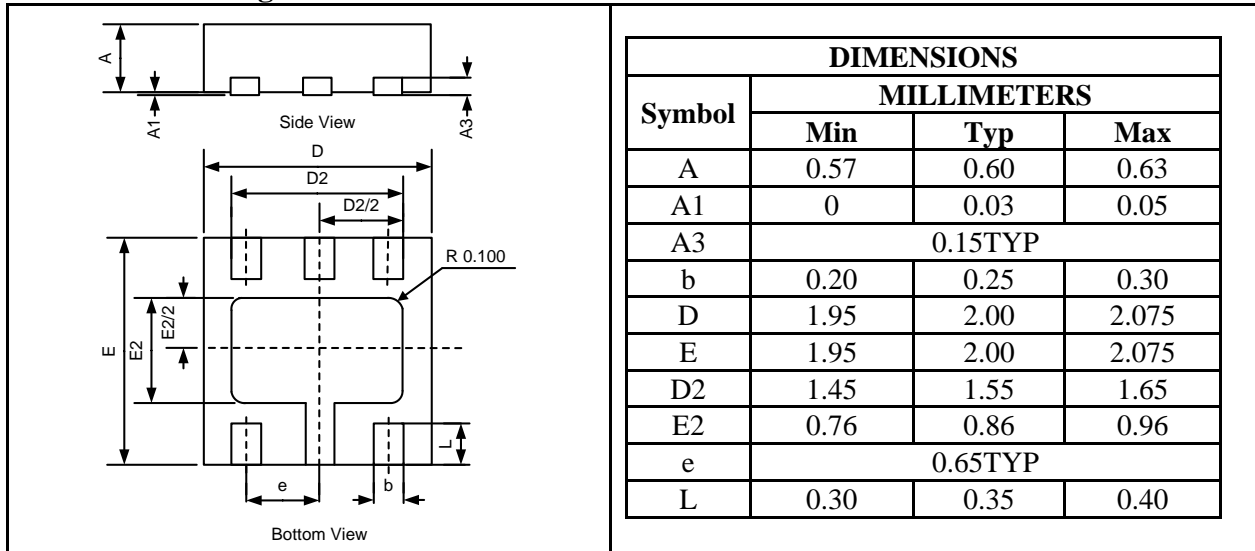

### Land Pattern

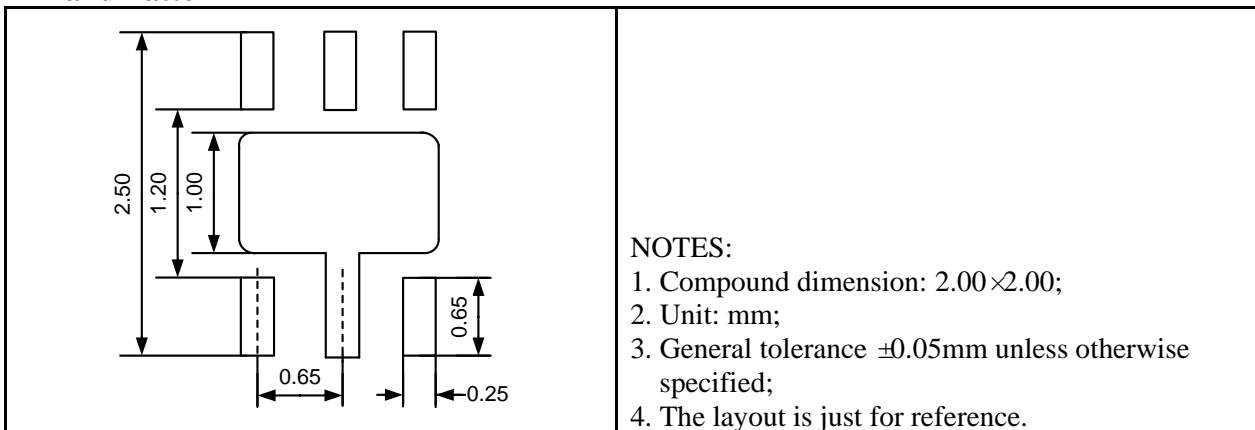

### Tape and Reel Orientation



## UM4750DB-xx DFN8 3.0×3.0

### Outline Drawing

DIMENSIONS				
Symbol	MILLIMETERS		INCHES	
	Min	Max	Min	Max
A	0.7	0.8	0.028	0.031
A1	0	0.05	0	0.002
A3	0.2 REF		0.008 REF	
b	0.25	0.35	0.01	0.014
D	2.95	3.05	0.116	0.12
E	2.95	3.05	0.116	0.12
D2	2.3	2.55	0.091	0.1
E2	1.5	1.75	0.059	0.069
e	0.650BSC		0.026BSC	
L	0.3	0.5	0.012	0.02

### Land Pattern

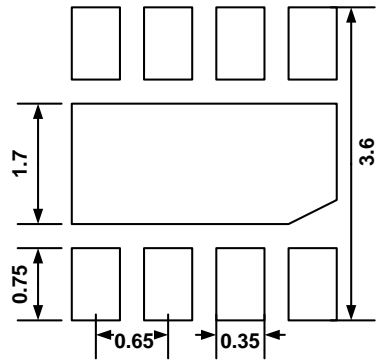
	<p>NOTES:</p> <ol style="list-style-type: none"> <li>1. Compound dimension: 3.00×3.00;</li> <li>2. Unit: mm;</li> <li>3. General tolerance <math>\pm 0.05\text{mm}</math> unless otherwise specified;</li> <li>4. The layout is just for reference.</li> </ol>
---	--

### Tape and Reel Orientation

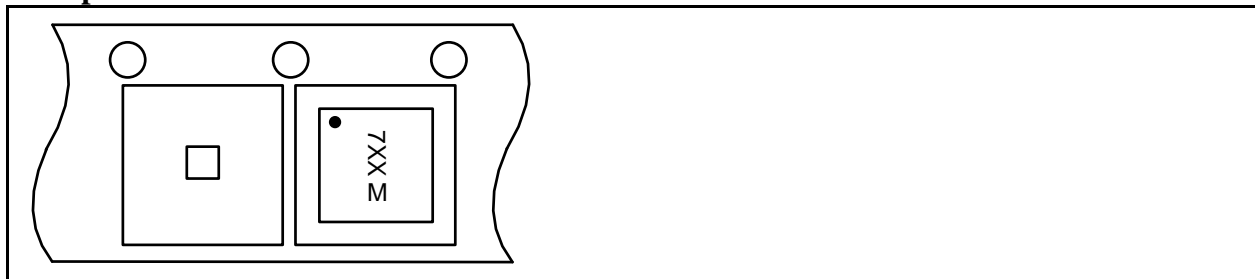

---

**IMPORTANT NOTICE**

The information in this document has been carefully reviewed and is believed to be accurate. Nonetheless, this document is subject to change without notice. Union assumes no responsibility for any inaccuracies that may be contained in this document, and makes no commitment to update or to keep current the contained information, or to notify a person or organization of any update. Union reserves the right to make changes, at any time, in order to improve reliability, function or design and to attempt to supply the best product possible.



Union Semiconductor, Inc

Add: 2F, No. 3, Lane647 Songtao Road, Shanghai 201203

Tel: 021-51093966

Fax: 021-51026018

Website: [www.union-ic.com](http://www.union-ic.com)