

**HYBRID - HIGH RELIABILITY
RADIATION TOLERANT
DC-DC CONVERTER**

Description

The AMF28XXS series of DC-DC converter modules has been specifically designed for operation in moderate radiation environments supplementing the higher radiation performance available in the International Rectifier ART, ARH and G-Series converters. Environments presented to space vehicles operating in low earth orbits, launch boosters, orbiting space stations and similar applications requiring a low power, high performance converter with moderate radiation hardness performance will be optimally served by the AMF28XXS Series.

The physical configuration of the AMF28XXS series permits mounting directly to a heat dissipation surface without the necessity of signal leads penetrating the heat sink surface. This package configuration permits greater independence in mounting and more mechanical security than traditional packages. International Rectifier's rugged ceramic seal pins are used exclusively in the package thereby assuring long term hermeticity.

The AMF28XXS has been designed for high density using chip and wire hybrid technology that complies with the class H requirements of MIL-PRF-38534. Manufactured in a facility fully qualified to MIL-PRF-38534, these converters are fabricated utilizing DLA qualified processes. For available screening options, refer to device screening table in the data sheet. Applicable generic lot qualification test data including radiation performance can be made available on request. Consult IR San Jose for special requirements.

**AMF28XXS SERIES
28V Input, Single Output**

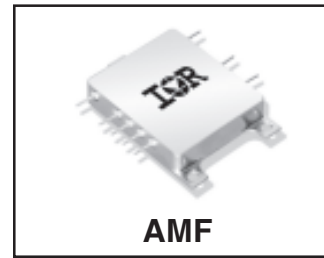

Features

- 12Watts Output Power
- Available in 3.3, 5, 7.5, 12 and 15Volt Outputs
- 16 - 40VDC Input Range (28VDC Nominal)
- Low Input/Output Noise
- Total Ionizing Dose > 25KRads (Si)
- SEE Hardened to LET up to 60MeV.cm²/mg
- -55°C to +125°C Operating Range
- Indefinite Short Circuit Protection
- Flexible Mounting
- High Power Density
- Fully Isolated - Input to Output and to Case
- Complimentary EMI Filter Available
- Synchronizable From An External Source
- Electrical Performance Similar to AHF28XXS Series
- Standard Microcircuit Drawings Available

AMF28XXS Series (28V Input, Single Output)

International
IRF Rectifier

Specifications

Absolute Maximum Ratings		Recommended Operating Conditions	
Input Voltage range	-0.5V to +50VDC	Input Voltage range	+16V to +40VDC
Soldering temperature	300°C for 10 seconds	Output Power	Less than or equal to 12W
Storage case temperature	-65°C to +135°C	Operating case temperature	-55°C to +125°C

Static Characteristics $-55^{\circ}\text{C} \leq T_{\text{CASE}} \leq +125^{\circ}\text{C}$, $V_{\text{IN}} = 28\text{V}_{\text{DC}} \pm 5\%$, $C_L = 0$, unless otherwise specified.

Parameter	Group A Subgroups	Test Conditions	Min	Nom	Max	Unit
Input Voltage			16	28	40	V
Output Voltage		$V_{\text{in}} = 28$ Volts, 0% load				
AMF2803R3S	1		3.25	3.30	3.35	V
AMF2805S	1		4.95	5.00	5.05	
AMF2807R5S	1		6.97	7.50	7.58	
AMF2812S	1		11.88	12.00	12.12	
AMF2815S	1		14.85	15.00	15.15	
AMF2803R3S	2, 3		3.20		3.40	
AMF2805S	2, 3		4.90		5.10	
AMF2807R5S	2, 3		7.35		7.65	
AMF2812S	2, 3		11.76		12.24	
AMF2815S	2, 3		14.70		15.30	
Output Current ¹		$V_{\text{in}} = 16, 28, 40$ Volts				
AMF2803R3S	1, 2, 3		0		3000	mA
AMF2805S	1, 2, 3		0		2400	
AMF2807R5S	1, 2, 3		0		1600	
AMF2812S	1, 2, 3		0		1000	
AMF2815S	1, 2, 3		0		800	
Output Power ¹		$V_{\text{in}} = 16, 28, \text{ and } 40$ Vdc				
AMF2803R3S	1, 2, 3				10	W
All Others	1, 2, 3				12	
Output Ripple Voltage ²	1, 2, 3	$V_{\text{in}} = 16, 28, 40$ Volts, BW = 20 Hz to 2 MHz		25	60	mV _{PP}
Output Voltage Regulation		$V_{\text{in}} = 16, 28, 40$ Volts $I_{\text{out}} = 0\%, 50\%, \text{ and } 100\%$ max				
Line				10	25	mV
AMF2803R3S	1, 2, 3			10	25	
AMF2805S	1, 2, 3			10	50	
AMF2807R5S	1, 2, 3			10	50	
AMF2812S	1, 2, 3			10	50	
AMF2815S	1, 2, 3			10	50	
Load	All			10	50	

For Notes to Specifications, refer to page 5

Static Characteristics (Continued) $-55^{\circ}\text{C} \leq T_{\text{CASE}} \leq +125^{\circ}\text{C}$, $V_{\text{IN}} = 28 \text{ V}_{\text{DC}} \pm 5\%$, $C_{\text{L}} = 0$, unless otherwise specified.

Parameter	Group A Subgroups	Test Conditions	Min	Nom	Max	Unit	
Input Current	No Load	$V_{\text{in}} = 28\text{V}$, $I_{\text{out}} = 0$, Inhibit (pin 1) = open (AMF2812S and AMF2815S) (All other Models)		30 20	50 30	mA	
	Inhibit	Inhibit (pin 1) shorted to input return (pin 7) (All Models)		8.0	12		
Input Ripple Current	1, 2, 3	$V_{\text{in}} = 16, 28, 40 \text{ Volts}$, 100% load, BW = 20 Hz to 2 MHz		20	50	mA_{PP}	
Efficiency	AMF2803R3S	100% load		71		%	
	AMF2805S			76			
	AMF2807R5S			77			
	AMF2812S			78			
	AMF2815S			78			
	AMF2803R3S			2, 3			70
	AMF2805S			2			72
	AMF2807R5S			2			73
	AMF2812S			2			75
	AMF2815S			2			75
Isolation	1	Input to output or any pin to case (except pin 6) at 500Vdc	100			$\text{M}\Omega$	
Capacitive Load ^{3,4}	AMF2803R3S	No effect on dc performance			500	μF	
	AMF2805S				500		
	AMF2807R5S				300		
	AMF2812S				200		
	AMF2815S				200		
					4		
Short Circuit Power Dissipation	1, 2, 3	AMF2803R3S All other Models			7.0	W	
					6.0		
Short Circuit Recovery ⁴	4, 5, 6	0% load to 100% Load			20	ms	
Switching Frequency	4, 5, 6	100% load	500	550	600	KHz	
MTBF		MIL-HDBK-217F SF @ $T_c = 35^{\circ}\text{C}$	750			Khr	
Weight					36	g	

For Notes to Specifications, refer to page 5

AMF28XXS Series (28V Input, Single Output)

International
IRF Rectifier

Dynamic Characteristics $-55^{\circ}\text{C} \leq T_{\text{CASE}} \leq +125^{\circ}\text{C}$, $V_{\text{IN}} = 28 \text{ V}_{\text{DC}} \pm 5\%$, $C_{\text{L}} = 0$, unless otherwise specified.

Parameter	Group A Subgroups	Test Conditions	Min	Nom	Max	Unit
Synchronization Input						
Frequency Range	4, 5, 6		500		700	KHz
Pulse Amplitude, Hi ⁴			2.5		10	V
Pulse Amplitude, Lo ⁴			-0.5		0.8	V
Pulse Rise time ⁴					100	ns
Pulse Duty Cycle ⁴			20		80	%
Output Response To Step Transient Load Changes⁵						
All	4, 5, 6	Load step 50% ⇔ 100%	-300		+300	mVpk
AMF2803R3S	4, 5, 6	Load step 0% ⇔ 50%	-400		+400	
AMF2805S	4, 5, 6		-500		+500	
AMF2807R5S	4, 5, 6		-750		+750	
AMF2812S	4, 5, 6		-750		+750	
AMF2815S	4, 5, 6		-750		+750	
Recovery Time, Step Transient Load Changes^{5,6}						
AMF2803R3S	4, 5, 6	Load step 50% ⇔ 100%			70	μs
AMF2805S	4, 5, 6				70	
AMF2807R5S	4, 5, 6				100	
AMF2812S	4, 5, 6				100	
AMF2815S	4, 5, 6				100	
All	4, 5, 6	Load step 0% ⇔ 50%			2.0	ms
Output Response Transient Step Line Changes^{4,7}						
AMF2803R3S	4, 5, 6	Input step 16 ⇔ 40Vdc 100% Load	-500		+500	mVpk
AMF2805S	4, 5, 6		-500		+500	
AMF2807R5S	4, 5, 6		-1200		+1200	
AMF2812S	4, 5, 6		-1500		+1500	
AMF2815S	4, 5, 6		-1500		+1500	
Recovery Time Transient Step Line Changes^{4,7}	4, 5, 6	Input step 16 ⇔ 40Vdc, 100% load			800	μs
Turn On Overshoot⁸						
AMF2803R3S	4, 5, 6	0% load to 100% load			400	mVpk
AMF2805S	4, 5, 6				600	
AMF2807R5S	4, 5, 6				600	
AMF2812S	4, 5, 6				600	
AMF2815S	4, 5, 6				750	
Turn On Delay⁸	4, 5, 6	0% load to 100% load			20	ms

For Notes to Specifications, refer to page 5

Notes to Specifications

- 1 Parameter guaranteed by line and load regulation tests.
- 2 Bandwidth guaranteed by design. Tested for 20Hz to 2.0MHz.
- 3 Capacitive load may be any value from 0 to the maximum limit without compromising dc performance. A capacitive load in excess of the maximum limit will not disturb loop stability but may interfere with the operation of the load fault detection circuitry, appearing as a short circuit during turn on.
- 4 Parameter shall be tested as part of design characterization and after design or process changes. Therefore this Parameters shall be guaranteed to the limit specified.
- 5 Load step transition time between 2.0 and 10 microseconds.
- 6 Recovery time is measured from the initiation of the transient to where V_{OUT} has returned to within $\pm 1\%$ of V_{OUT} at 50 percent load.
- 7 Input step transition time between 1.0 and 10 microseconds. Parameter guaranteed by design but not 100% tested.
- 8 Turn on delay time measurement is for either a step application of power at the input or the removal of a ground signal from the inhibit pin while power is applied to the input.

Block Diagram

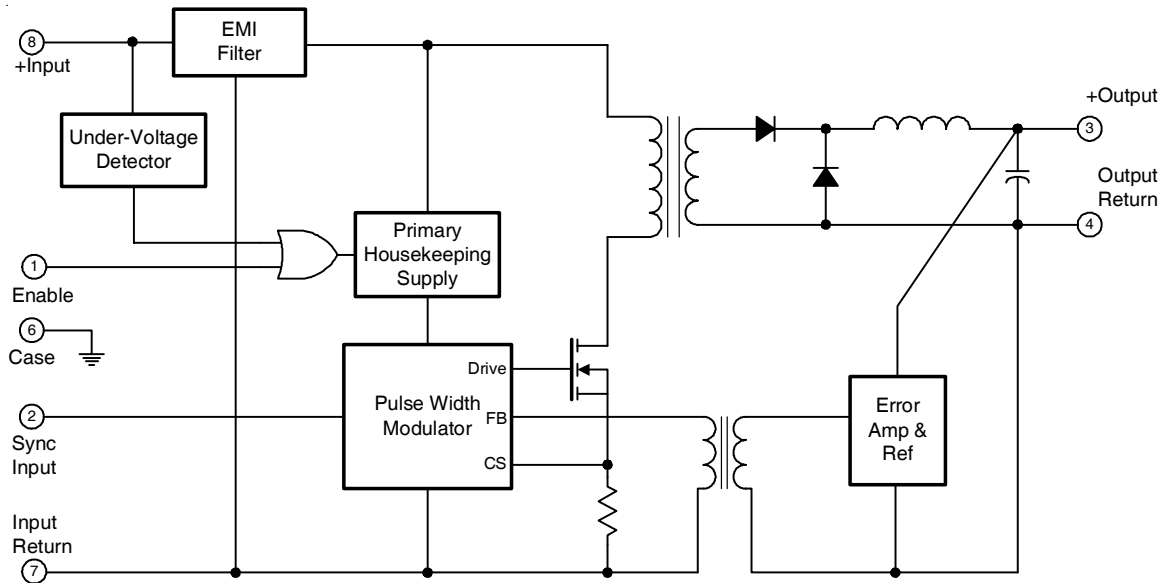

Application Information

Inhibit Function (Enable)

Connecting the enable input (Pin 1) to input common (Pin 7) will cause the converter to shut down. It is recommended that the enable pin be driven by an open collector device capable of sinking at least 400 μ A of current. The open circuit voltage of the enable input is 10 +1.0 VDC.

EMI Filter

An optional EMI filter is available (AFH461) that will reduce the input ripple current to levels below the limits imposed by MIL-STD-461 CE03.

Device Synchronization

When multiple DC-DC converters are utilized in a single system, significant low frequency noise may be generated due to a small difference in the switching frequency of the converters (beat frequency noise). Because of the low frequency nature of this noise (typically less than 10 KHz), it is difficult to filter out and may interfere with proper operation of sensitive systems (communication, radar or telemetry). International Rectifier provides synchronization of multiple AMF type converters to match switching frequency of the converter to the frequency of the system clock, thus eliminating this type of noise.

**AMF28XXS Series
(28V Input, Single Output)**

International
IR Rectifier

Mechanical Outline

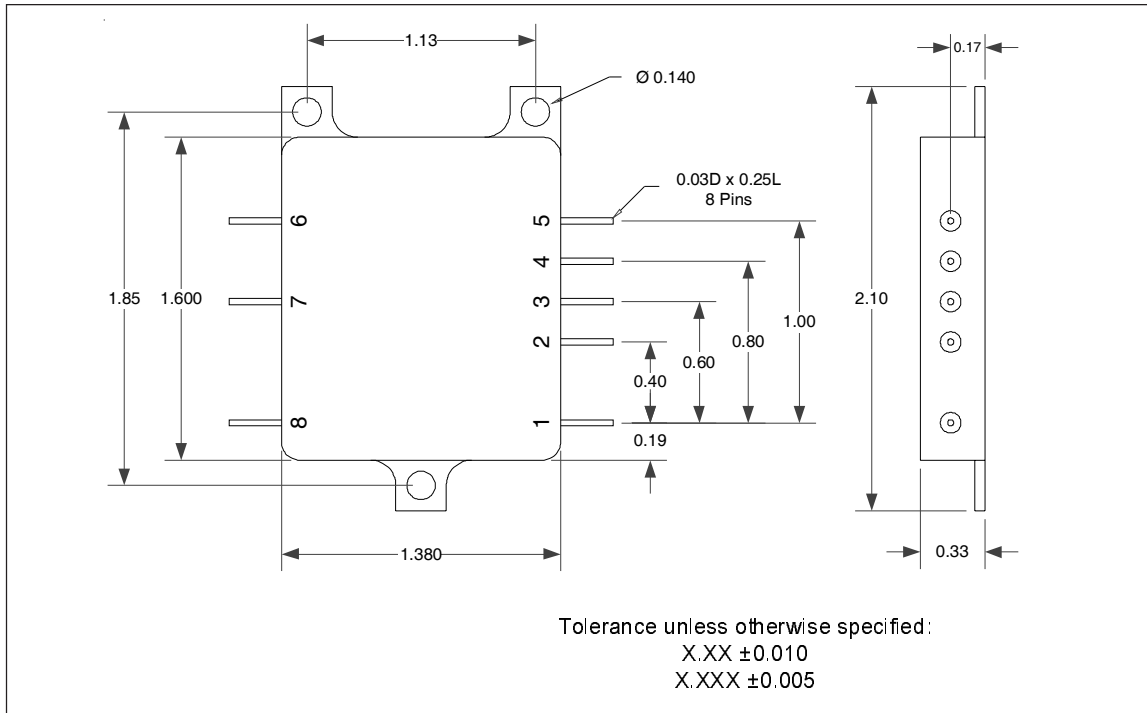

Pin Designation

Pin #	Designation
1	Enable
2	Sync. Input
3	+ Output
4	Output Return
5	NC
6	Case Ground
7	Input Return
8	+ Input

Standard Microcircuit Drawing Equivalence Table

Standard Microcircuit Drawing Number	IR Standard Part Number
5962-04252	AMF2805S
5962-04253	AMF2812S
5962-04254	AMF2815S
5962-10223	AMF2803R3S

Radiation Specification

Parameter	Condition	Min	Typ	Max	Unit
Total Ionizing Dose	MIL-STD-883, Method 1019.4 Operating bias applied during exposure	25	—	—	KRads (Si)
Heavy Ion (Single event effects)	BNL Dual Van de Graf Generator	60	—	—	MeV •cm ² /mg

International Rectifier currently does not have a DLA certified Radiation Hardness Assurance Program.

Device Screening

Requirement	MIL-STD-883 Method	No Suffix ②	CH ②	EM
Temperature Range	—	-55°C to +125°C	-55°C to +125°C	-55°C to +85°C
Element Evaluation	MIL-PRF-38534	Class H	Class H	N/A
Non-Destructive Bond Pull	2023	N/A	N/A	N/A
Internal Visual	2017	Yes	Yes	①
Temperature Cycle	1010	Cond C	Cond C	Cond C
Constant Acceleration	2001, Y1 Axis	3000 Gs	3000 Gs	3000 Gs
PIND	2020	Cond A	Cond A	N/A
Burn-In	1015	320 hrs @ 125°C (2 x 160hrs)	320 hrs @ 125°C (2 x 160hrs)	48 hrs @ 125°C
Final Electrical (Group A)	MIL-PRF-38534 & Specification	-55°C, +25°C, +125°C	-55°C, +25°C, +125°C	-55°C, +25°C, +85°C
PDA	MIL-PRF-38534	2%	2%	N/A
Seal, Fine and Gross	1014	Cond A, C	Cond A, C	Cond A
Radiographic	2012	Yes	Yes	N/A
External Visual	2009	Yes	Yes	①

Notes:

① Best commercial practice.

② Device with 'CH' suffix is a DLA class H compliant without radiation performance. No suffix is a radiation rated device but not available as a DLA qualified SMD per MIL-PRF-38534.

International Rectifier currently does not have a DLA certified Radiation Hardness Assurance Program.

Part Numbering

