

R. 0.13  
(4 PL)

**RECOMMENDED PANEL MOUNTING**

\* DIMENSION IS 15.75/15.88 FOR PANEL THICKNESS BETWEEN 1.52mm TD 3.18mm

12.70

\*15.24

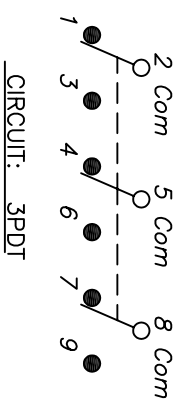

SWITCH FUNCTION			
POS. 1	POS. 2	POS. 3	
DN	NDNE	DN	
2-3,5-6,8-9	DPEN	2-1,5-4,8-7	

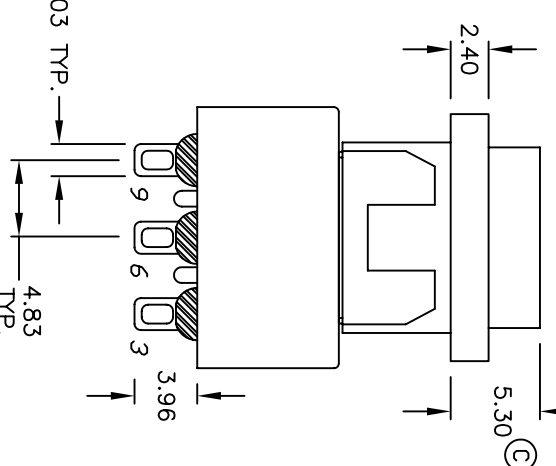
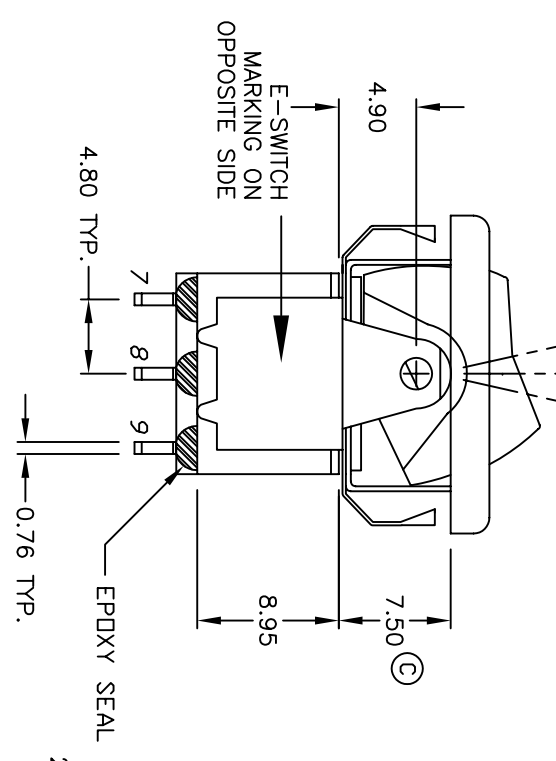

- NOTES:
1. ALL DIMENSIONS IN MM
  2. GENERAL TOLERANCE: X.X=±0.4 X.XX=±0.25
  3. TERM. NOS. FOR REF. ONLY
  4. RATING: 5A @120VAC OR 28VDC 2A @250VAC
  5. MATERIAL: FIXED TERMINAL & MOVING CONTACT  
Copper Alloy w/Silver Plate
  6. CONTACT RESISTANCE: 10 Milli-Ohms max initial @2-4VDC, 100mA for AG & AU
  7. ELECTRICAL LIFE: 50,000 make-and-break cycles at full load.
  8. INSULATION RESISTANCE: 1,000M Ohms min.
  9. DIELECTRIC STRENGTH: 1000V RMS @sed level
  10. OPERATING TEMP.: -30°C to 85°C
  11. 2002/95/EC (ROHS) COMPLIANT

C	18044	7.50 WAS 7.11, 5.30 WAS 5.64	3/31/08	BLR
B	12120	DIMENSION WAS 20.10	5/6/02	CB
A	12111	RELEASED FOR PRODUCTION	5/1/02	CB
REV.	ECN No.	DESCRIPTION	DATE	CHKD

TITLE		SCALE		DATE		DR		DWG		REV	
300 3P-1 R6 BLK M1 Q E BLK		2:1		3/31/08		BLR		T331023		C	

THE INFORMATION CONTAINED IN THIS DOCUMENT IS PROPRIETARY TO E-SWITCH AND IS NOT TO BE COPIED OR TRANSFERRED