

Low Voltage, High Bandwidth, USB 2.0, 4:1 Mux/DeMux with Single Enable

Features

- Near-Zero propagation delay
- 5Ω switches connect inputs to outputs
- High signal passing bandwidth (-3dB BW is 815MHz)
- Beyond Rail-to-Rail switching
- 5V I/O tolerant with 3.3V supply
- 3.3V supply voltage operation
- Hot insertion capable
- Industrial operating temperature: -40°C to +85°C
- ESD protection
 - 8kV per JESD22 test spec (HBM)
 - +/-4kV per IEC61000-4-2 spec (contact)
- Latch-up performance >250mA per JESD17
- Packaging (Pb-free & Green available):
 - 16-pin 150-mil wide plastic QSOP (Q)
 - 16-pin 173-mil wide plastic TSSOP (L)
 - 20-contact TQFN (ZH)

Block Diagram

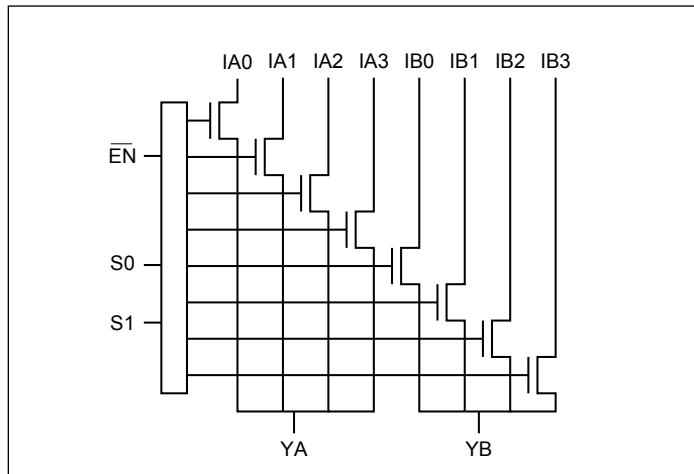

Truth Table⁽¹⁾

Enable	Select		Y	Function
\overline{EN}	S ₁	S ₀	Y	Function
H	X	X	Hi-Z	Disable
L	L	L	I0	S1-0 = 0
L	L	H	I1	S1-0 = 1
L	H	L	I2	S1-0 = 2
L	H	H	I3	S1-0 = 3

Note: 1. H=High Voltage Level; L=Low Voltage Level

Description

The PI3USB14-A is a 2-channel, 4:1 Multiplexer/Demultiplexer with 3-state outputs. The switch introduces no additional ground bounce noise or propagation delay.

The PI3USB14-A device is very useful in switching USB 2.0 signals and others that have high bandwidth (-3dB BW is 815MHz).

Pin Configuration

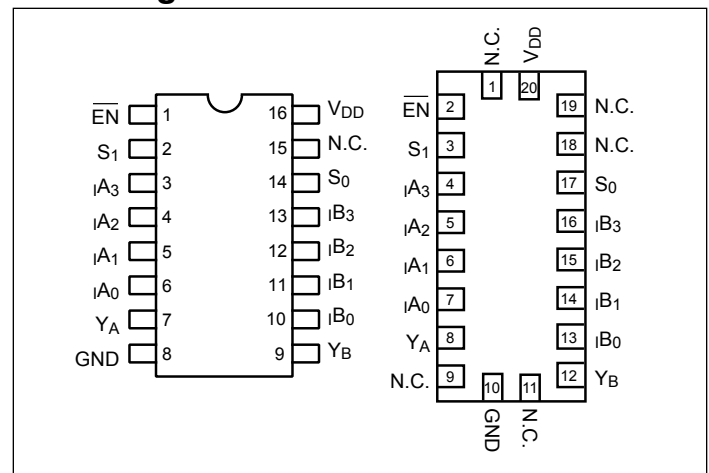

Note:

1. N.C. = No internal connection

Pin Description

Pin Name	Description
I _A N, I _B N	Data Inputs
S ₀₋₁	Select Inputs
\overline{EN}	Enable
Y _A to Y _B	Data Outputs
GND	Ground
V _{DD}	Power

Maximum Ratings

(Above which the useful life may be impaired. For user guidelines, not tested.)

Storage Temperature	-65°C to +150°C
Ambient Temperature with Power Applied	-40°C to +85°C
Supply Voltage to Ground Potential	-0.5V to +4.6V
DC Input Voltage	-0.5V to +6.0V
DC Output Current.....	120mA
Power Dissipation	0.5W

Note:

Stresses greater than those listed under MAXIMUM RATINGS may cause permanent damage to the device. This is a stress rating only and functional operation of the device at these or any other conditions above those indicated in the operational sections of this specification is not implied. Exposure to absolute maximum rating conditions for extended periods may affect reliability.

DC Electrical Characteristics, 3.3V Supply

(Over the Operating Range, $T_A = -40^\circ\text{C}$ to $+85^\circ\text{C}$, $V_{DD} = 3.3\text{V} \pm 10\%$)

Parameters	Description	Test Conditions ⁽¹⁾	Min.	Typ. ⁽²⁾	Max.	Units
V_{IH}	Input HIGH Voltage	Guaranteed Logic HIGH Level	1.3			V
V_{IL}	Input LOW Voltage	Guaranteed Logic LOW Level			0.6	
V_{IK}	Clamp Diode Voltage	$V_{DD} = \text{Min.}, I_{IN} = -18 \text{ mA}$		-1.3	-1.8	
I_{IH}	Input HIGH Current	$V_{DD} = \text{Max.}, V_{IN} = V_{DD}$			± 1	μA
I_{IL}	Input LOW Current	$V_{DD} = \text{Max.}, V_{IN} = \text{GND}$			± 1	
I_{OZH}	High Impedance Output Current	$0 \leq Y, I_n \leq V_{DD}$			± 1	
R_{ON}	Switch On-Resistance ⁽⁴⁾	$V_{DD} = \text{Min.}, -0.4\text{V} \leq V_{\text{input}} \leq 0.4\text{V}, I_{ON} = -40\text{mA}$		4	6	Ω
		$0\text{V} \leq V_{\text{input}} \leq V_{DD}, I_{ON} = -40\text{mA}$		5	8	

Capacitance ($T_A = 25^\circ\text{C}$ $f = 1\text{ MHz}$)

Parameters ⁽⁵⁾	Description	Test Conditions	Typ.	Units
C_{IN}	Input Capacitance	$V_{IN} = 0\text{V}$	2.0	pF
$C_{OFF(IN)}$	In Capacitance, Switch Off		2.5	
$C_{OFF(Y)}$	Y Capacitance, Switch Off		4	
C_{ON}	Y/In Capacitance, Switch On		8	

Notes

1. For Max. or Min. conditions, use appropriate value specified under Electrical Characteristics for the applicable device type.
2. Typical values are at $V_{DD} = 3.3\text{V}$, $T_A = 25^\circ\text{C}$ ambient and maximum loading.
3. Not more than one output should be shorted at one time. Duration of the test should not exceed one second.
4. Measured by the voltage drop between Y and In pin at indicated current through the switch. On-Resistance is determined by the lower of the voltages on the two (Y, In) pins.
5. This parameter is determined by device characterization but is not production tested.

Power Supply Characteristics

Parameters	Description	Test Conditions ⁽¹⁾	Min.	Typ. ⁽²⁾	Max.	Units
I_{CC}	Quiescent Power Supply Current	$V_{DD} = 3.6\text{V}$, $V_{IN} = \text{GND or } V_{DD}$			60	μA

Notes:

1. For Max. or Min. conditions, use appropriate value specified under Electrical Characteristics for the applicable device.
2. Typical values are at $V_{DD} = 3.3\text{V}$, $+25^\circ\text{C}$ ambient.
3. Per LVTTTL driven input (control inputs only); Y and In pins do not contribute to I_{CC} . This parameter is guaranteed, but not production tested.

Dynamic Electrical Characteristics Over the Operating Range

($T_A = -40^\circ$ to $+85^\circ$, $V_{DD} = 3.3V \pm 10\%$)

Parameter	Description	Test Condition	Min.	Typ.	Max.	Units
X_{TALK}	Crosstalk	DR at 480Mbps, See Test Diagram		-35		dB
O_{IRR}	Off-Isolation	DR at 480Mbps, See Test Diagram		-35		
BW	-3dB Bandwidth	See Test Diagram		815		MHz
IN	Insertion Loss	$f = 240\text{MHz}$, DR = 480Mbps		-0.5		dB

Switching Characteristics over 3.3V Operating Range

Parameters	Description	Conditions ⁽¹⁾	Com.			Units
			Min.	Typ.	Max.	
t_{PLH} t_{PHL}	Propagation Delay ^(2,3) Y to In, In to Y	See Test Diagram			0.3	ns

Notes:

1. See test circuit and waveforms.
2. This parameter is guaranteed but not tested on Propagation Delays.
3. The switch contributes no propagational delay other than the RC delay of the ON resistance of the switch and the load capacitance. The time constant for the switch alone is of the order of 0.30ns for 10pF load. Since this time constant is much smaller than the rise/fall times of typical driving signals, it adds very little propagational delay to the system. Propagational delay of the switch when used in a system is determined by the driving circuit on the driving side of the switch and its interaction with the load on the driven side.

Test Circuit for Electrical Characteristics⁽¹⁾

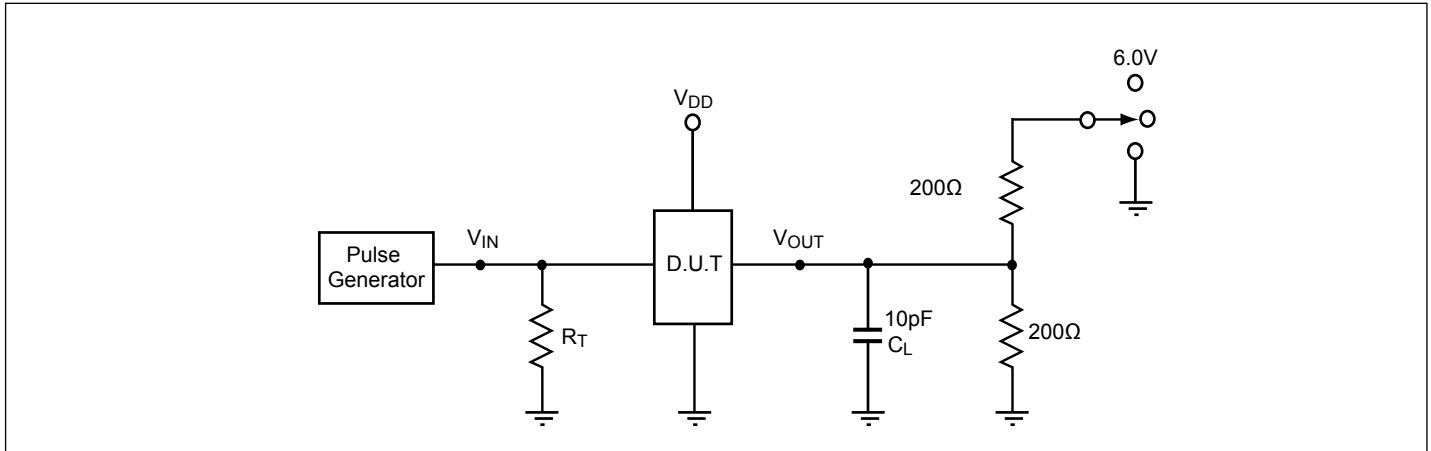

Notes:

1. CL = Load capacitance: includes jig and probe capacitance.
2. RT = Termination resistance: should be equal to ZOUT of the Pulse Generator
3. Waveform 1 is for an output with internal conditions such that the output is low except when disabled by the output control. Waveform 2 is for an output with internal conditions such that the output is high except when disabled by the output control.
4. All input impulses are supplied by generators having the following characteristics: PRR ≤ MHz, ZO = 50Ω, tR ≤ 2.5ns, tF ≤ 2.5ns.
5. The outputs are measured one at a time with one transition per measurement.

Switch Positions

Test	Switch
tPLZ, tPZL	6.0V
tPHZ, tPZH	GND
Prop Delay	Open

Test Circuit for Dynamic Electrical Characteristics

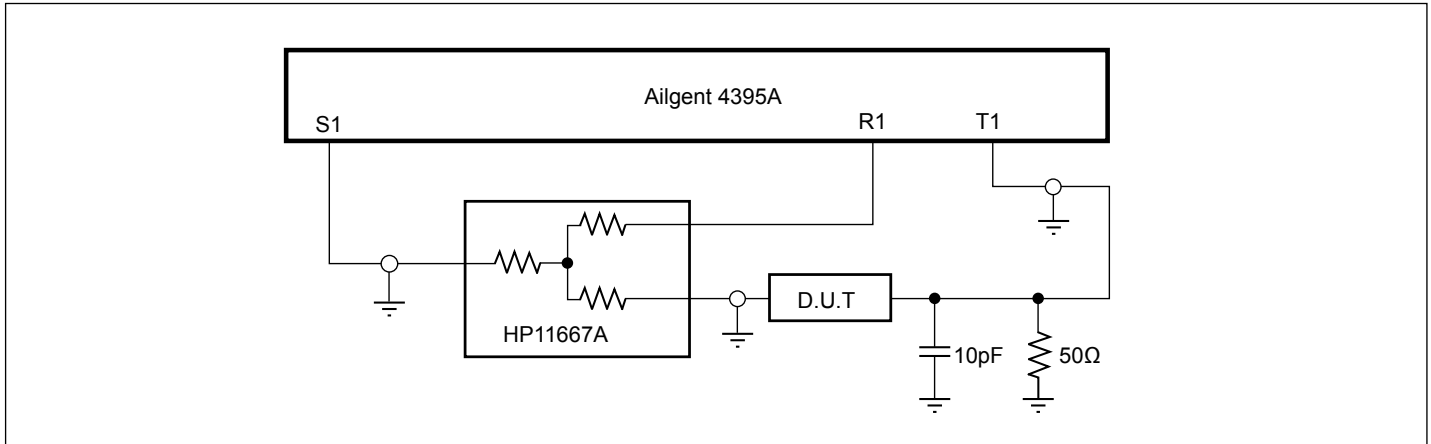

Switching Waveforms

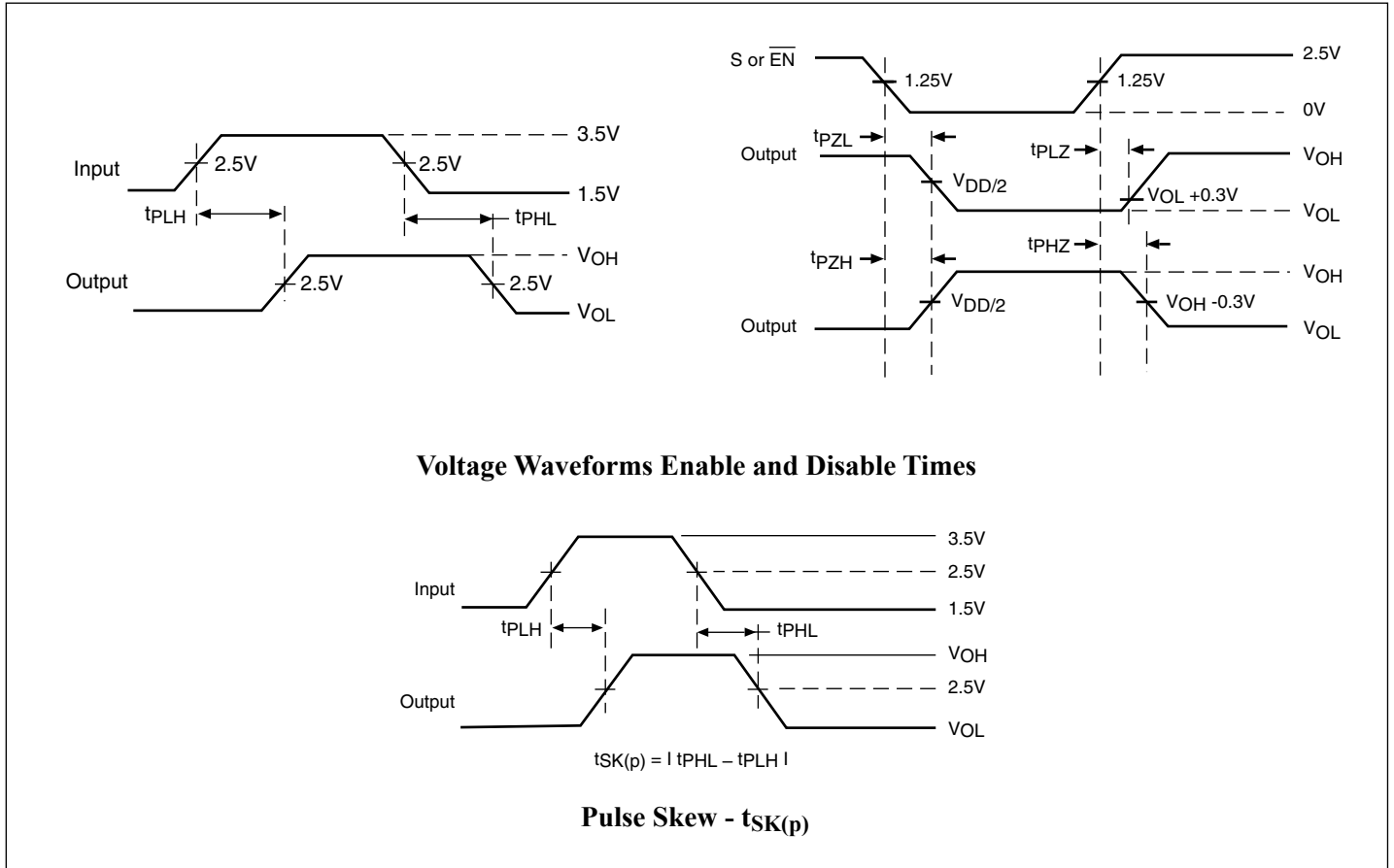

Applications Information

Logic Inputs

The logic control inputs can be driven up to 3.6V regardless of the supply voltage. For example, given a +3.3V supply, \overline{EN} maybe driven LOW to 0V and HIGH to 3.6V. Driving \overline{EN} Rail-to-Rail® minimizes power consumption.

Power Supply-Sequencing

Proper power supply sequencing is recommended for all CMOS devices. Always apply VDD before applying signals to the input/output or control pins.

Packaging Mechanical: 16-pin QSOP (Q)

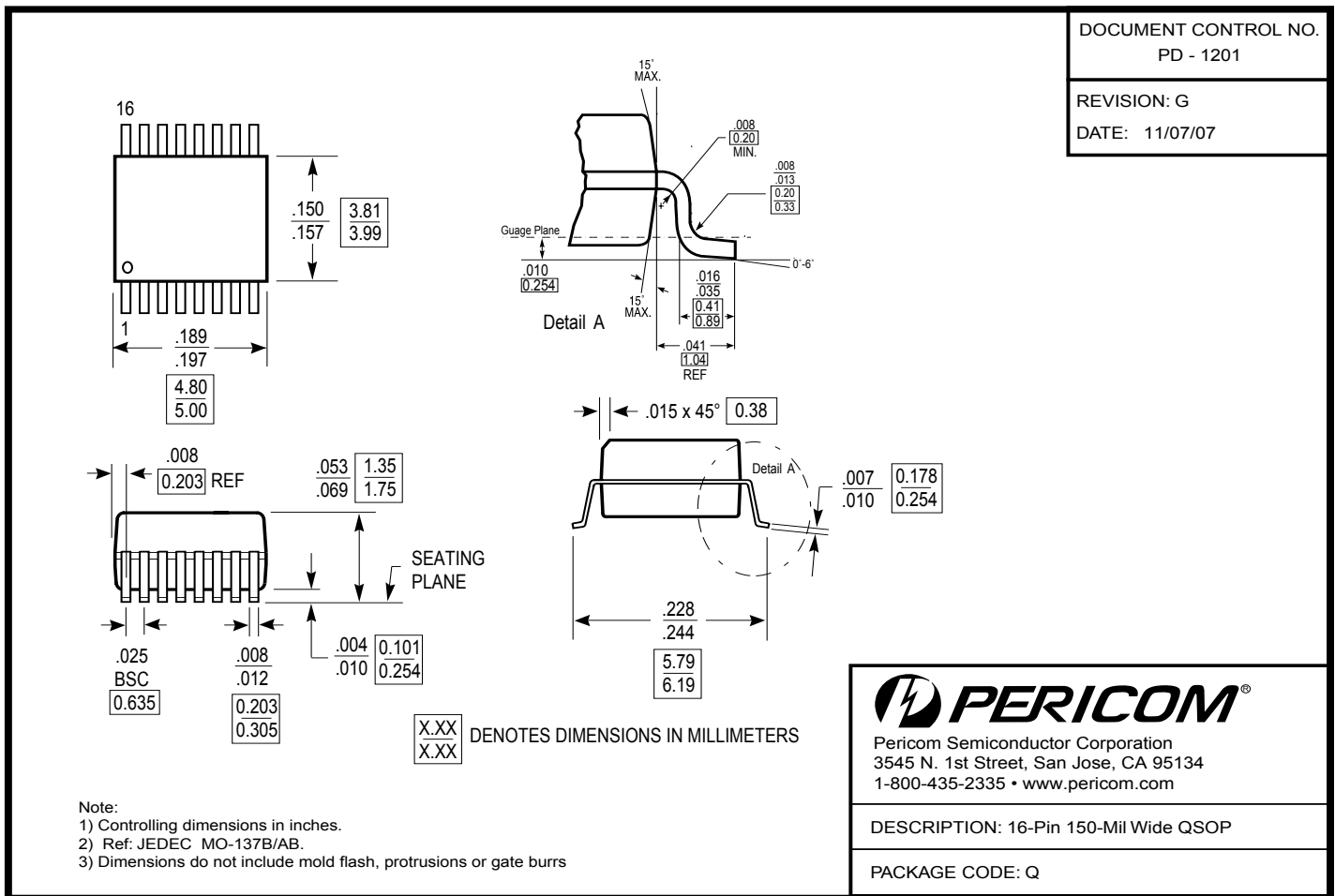

Packaging Mechanical: 16-pin TSSOP (L)

DOCUMENT CONTROL NO.
 PD - 1310

REVISION: E
 DATE: 03/09/05

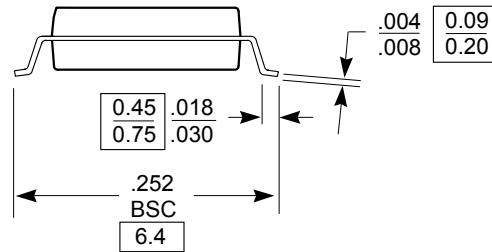
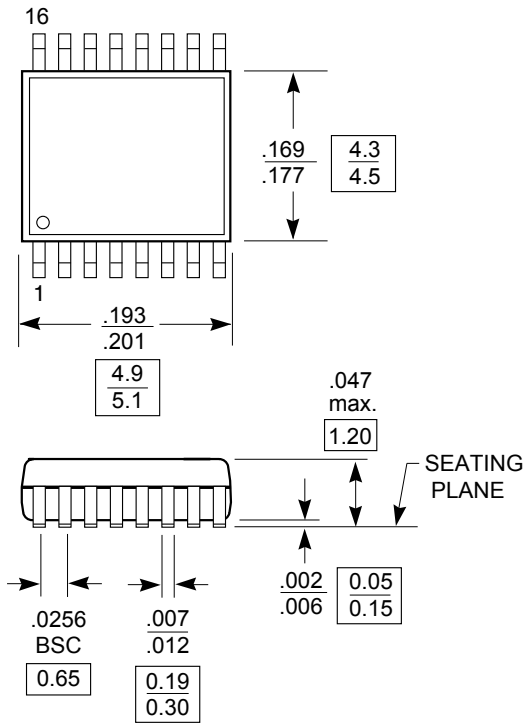

- Note:
1. Package Outline Exclusive of Mold Flash and Metal Burr
 2. Controlling dimensions in millimeters
 3. Ref: JEDEC MO-153F/AB



Pericom Semiconductor Corporation
 3545 N. 1st Street, San Jose, CA 95134
 1-800-435-2335 • www.pericom.com

DESCRIPTION: 16-Pin, 173-Mil Wide, TSSOP

PACKAGE CODE: L

Packaging Mechanical: 20-Contact TQFN (ZH)

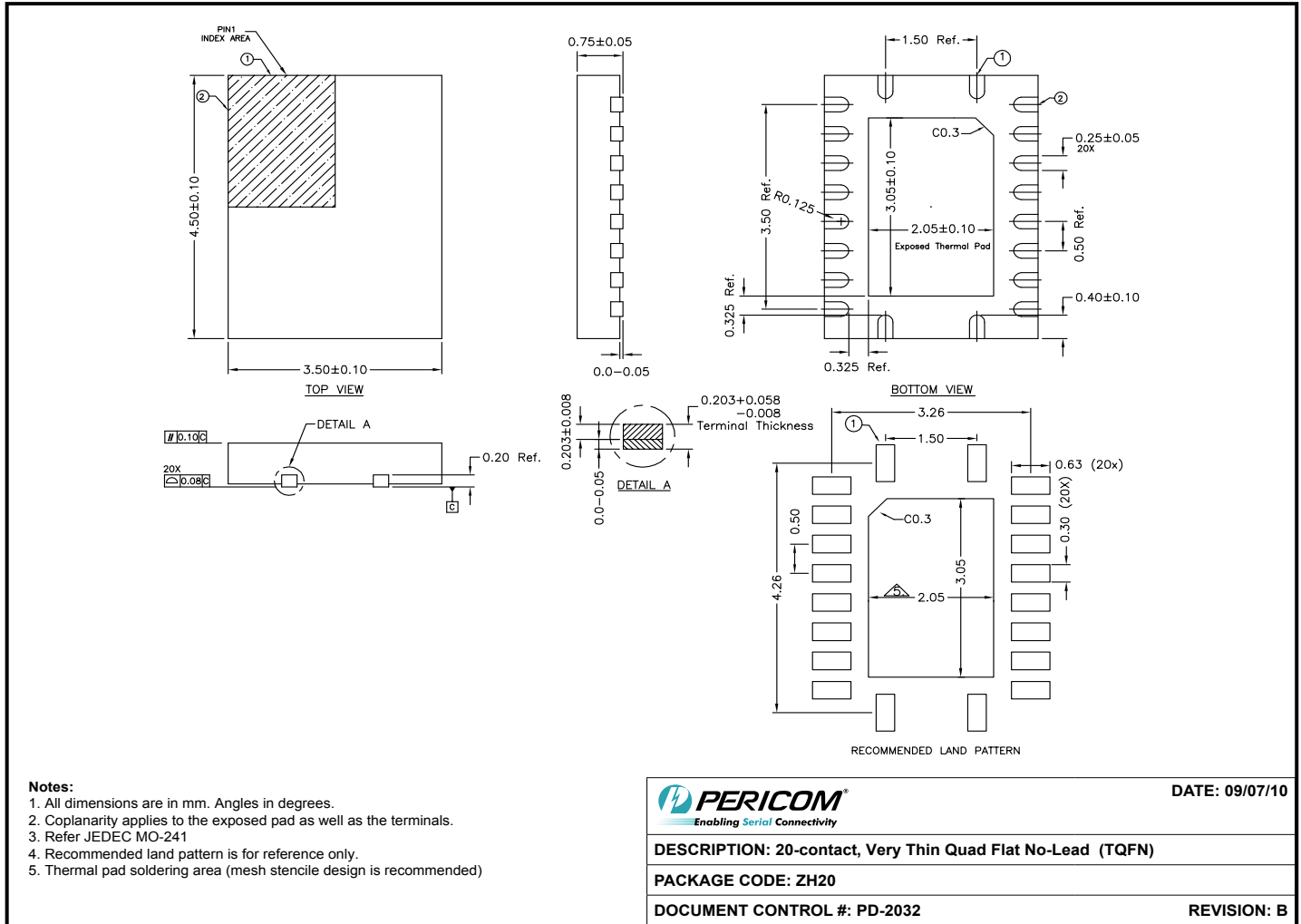

Ordering Information

Ordering Code	Packaging Type	Package Description
PI3USB14-AQE	Q	Pb-free & Green, 150-mil, 16-pin QSOP
PI3USB14-ALE	L	Pb-free & Green, 173-mil, 16-pin TSSOP
PI3USB14-AZHE	ZH	Pb-free & Green, 20-Contact TQFN

Notes:

- Thermal characteristics can be found on the company web site at www.pericom.com/packaging/
- "E" denotes Pb-free and Green
- Adding an "X" at the end of the ordering code denotes tape and reel packaging