

4

3

2

1

REVISIONS		
LTR	DESCRIPTION	DATE
C	ECO-08-009707	04/17/2008

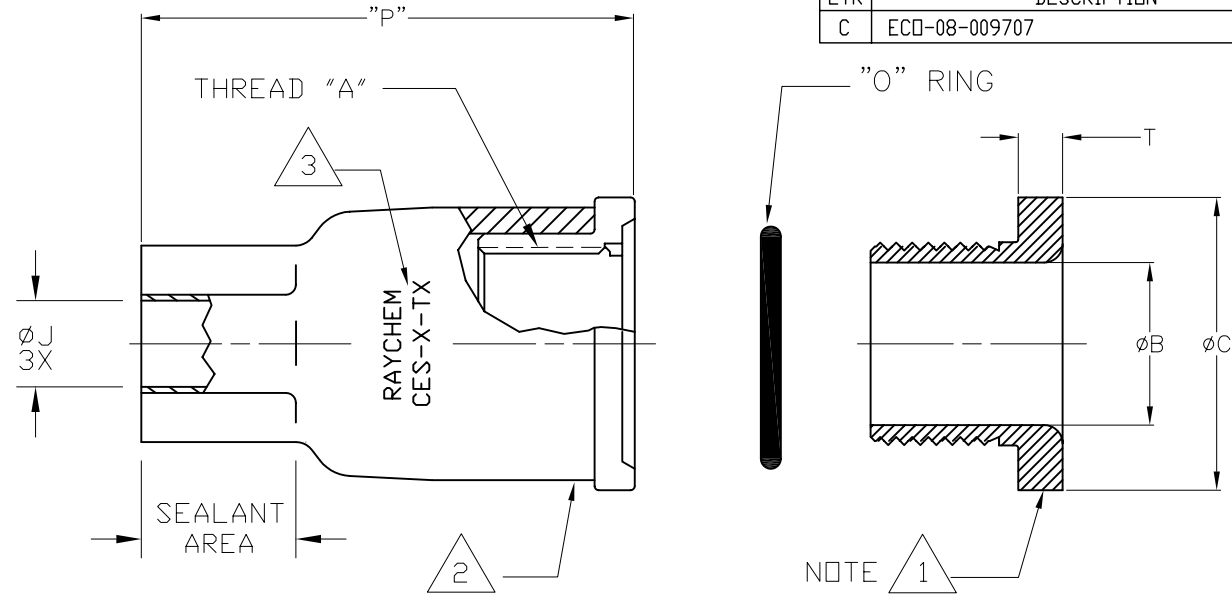
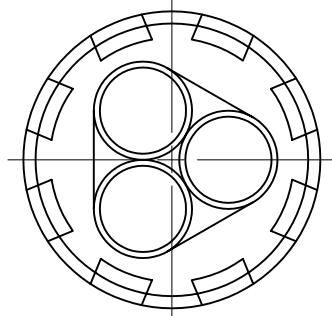

PART DESCRIPTION	"A" THREAD	ØB MIN	ØC MAX	ØJ		P REF REC	T REF	PANEL THK ⁴
				MIN EXP	MAX REC			
CES-2-T1	1-12 UNF	.76 [19,31]	1.41 [35,82]	.33 [8,38]	.12 [3,05]	3.50 [88,90]	.21 [5,33]	1/4 [6,35]
CES-3-T1	1 3/8-12 UNF	1.11 [28,20]	1.91 [48,52]	.60 [15,3]	.17 [4,57]	3.76 [95,5]	.31 [7,88]	1/4 [6,35]
CES-4-T1	2-8 UN	1.60 [40,64]	2.72 [69,09]	.82 [20,83]	.30 [7,62]	5.20 [132,08]	.31 [7,88]	3/8 [9,65]
CES-5-T4	3 3/8-8 UN	2.91 [73,92]	4.10 [104,14]	1.25 [31,75]	.50 [12,7]	5.20 [132,08]	.31 [7,88]	1/2 [12,7]

NOTES:

- ¹ MATERIAL: STANDARD BLACK NYLON
- ² HEAT SHRINKABLE BOOT MATERIAL IN ACCORDANCE WITH -3 POLYOLEFIN
- ³ PART TO BE MARKED AS SHOWN, REPLACE X'S WITH APPROPRIATE CHARACTERS (e.g. CES-2-T1).
- ⁴ THIS PART IS DESIGNED TO FIT THROUGH A PANEL OR BULKHEAD WITH A MAXIMUM WALL THICKNESS AS INDICATED IN TABLE.

If this document is printed it becomes uncontrolled. Check for the latest revision

CUSTOMER DRAWING

UNLESS OTHERWISE SPECIFIED DIMENSIONS ARE INCHES. METRIC DIMENSIONS ARE IN BRACKETS.	DRAWN	DATE	 Raychem Molded Parts 305 Constitution Dr Menlo Park, CA 94025
	UNGUYEN	04/17/2008	
DECIMAL TOLERANCES	THIRD ANGLE PROJECTION		TITLE
.XXX ± 0.005 [0.13 mm]			CABLE ENTRY SEAL, 3 ENTRY
.XX ± 0.01 [0.25 mm]			SIZE CODE IDENT. NO. DWG. NO.
.X ± 0.1 [0.50 mm]			B 06090 CES-X-TX
ANGLE TOLERANCE			DD NOT SCALE THIS DRAWING SHEET 1 OF 1
.X ± 1 DEG.			

© 2007-2008 Tyco Electronics Corporation. All rights reserved.