

Absolute Maximum Ratings¹

Parameter	Absolute Maximum
Max. Input Power	
50 MHz	+27 dBm
500-2000 MHz	+34 dBm
Control Voltage	+5 V, -8.5 V
Operating Temperature	-40°C to +85°C
Storage Temperature	-65°C to +150°C

1. Operation of this device above any one of these parameters may cause permanent damage

Functional Schematic

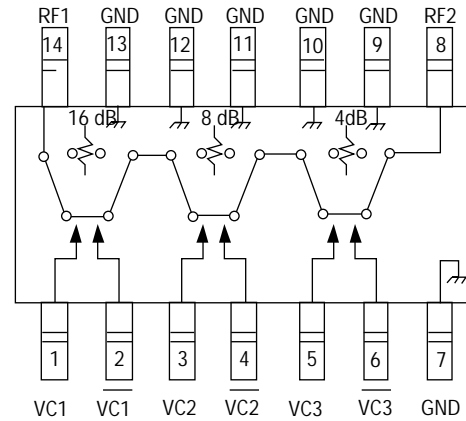

Truth Table

Control Input						Atten (dB)
$\overline{VC3}$	VC3	$\overline{VC2}$	VC2	$\overline{VC1}$	VC1	
1	0	1	0	1	0	Reference
0	1	1	0	1	0	4 dB
1	0	0	1	1	0	8 dB
1	0	1	0	0	1	16 dB
0	1	0	1	0	1	28 dB

0 = VIN Low = 0 V to -0.2 V @ 20 *A maximum
 1 = VIN High = -5 V @ 10 *A typ. to -8 V @ 200 *A maximum

Typical Performance

