

**SPECIFICATIONS FOR
LCD MODULE**

Module No. JHB12864G

E-mail: sales@jhlcd.com

Website: www.jhlcd.com

TABLE OF CONTENTS

LCM NUMBER SYSTEM	2
1. GENERAL DESCRIPTION	3
2. FEATURES.....	3
3. MECHANICAL SPECIFICATION	3
4. MECHANICAL DIMENSION	4
5. MAXIMUM RATINGS	5
6. ELECTRICAL CHARACTERISTICS	5
7. MODULE FUNCTION DESCRIPTION	6
8. ELECTRO-OPTICAL CHARACTERISTICS	16
9. RELIABILITY.....	20
10. PRECAUTIONS FOR USING LCD MODULES	21
11. USING LCD MODULES.....	23
12. REVISION HISTORY	25
SAMPLE APPROVED REPORT	26



LCM Number System

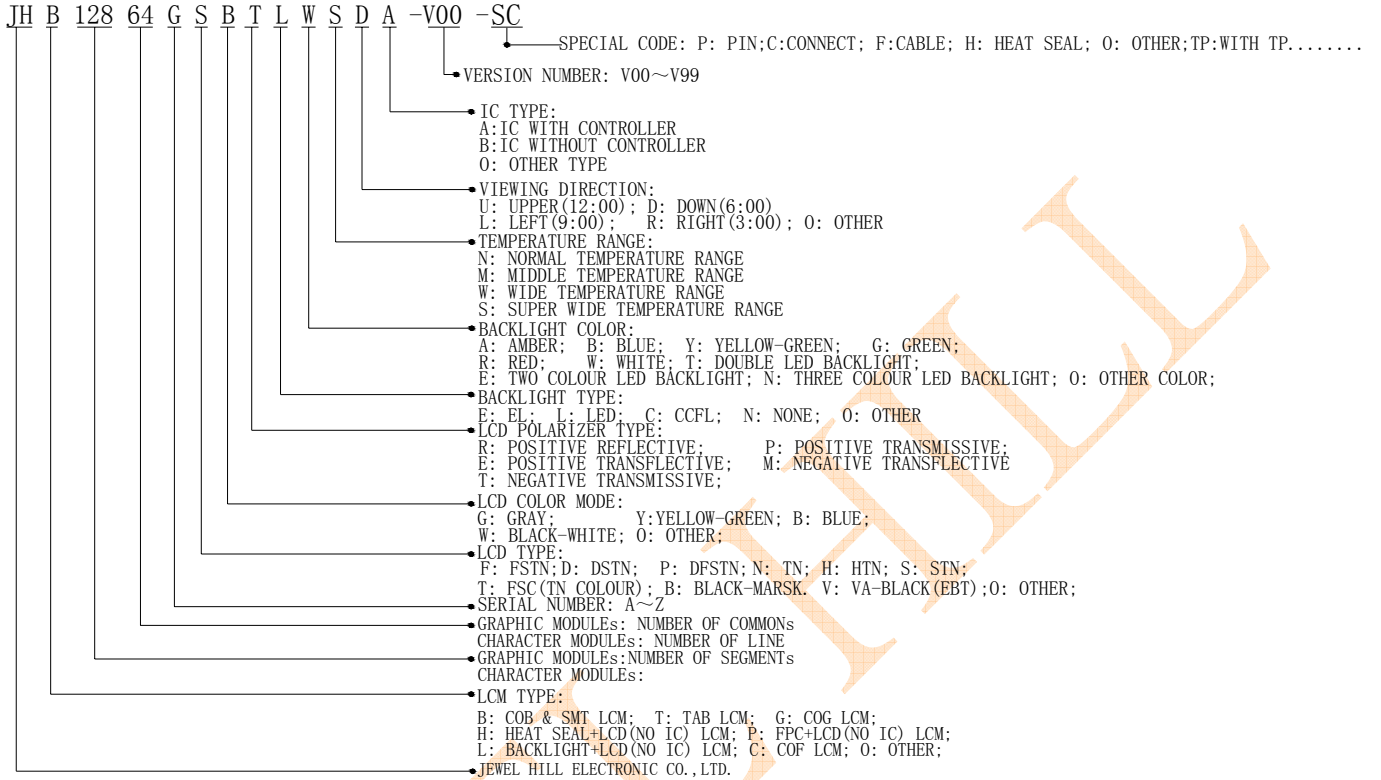

1. GENERAL DESCRIPTION

The JHB12864G is a 128 x 64 Dots Graphics LCD module. It has a STN panel composed of 128 segments and 64 commons. The LCM can be easily accessed by micro-controller via parallel interface.

2. FEATURES

Display Mode	Transmissive and Negative
	STN, Blue module
Display Format	Graphic 128 x 64 dots
Input Data	Parallel data input from MPU
Multiplexing Ratio	1/64Duty
Bias	1/9 Bias
Viewing Direction	6 O'clock
Backlight	LED(White)

3. MECHANICAL SPECIFICATION

Item	Specifications	Unit
Dimensional outline	78.0 x 70.0 x 12.0(max)	mm
Resolution	128segs x 64coms	dots
Viewing area	62.0(W) x 44.0(H)	mm
Active area	56.28(W) x 38.36(H)	mm
Dots pitch	0.44 (W)×0.6(H)	mm
Dots size	0.4 (W)×0.56(H)	mm

4. MECHANICAL DIMENSION

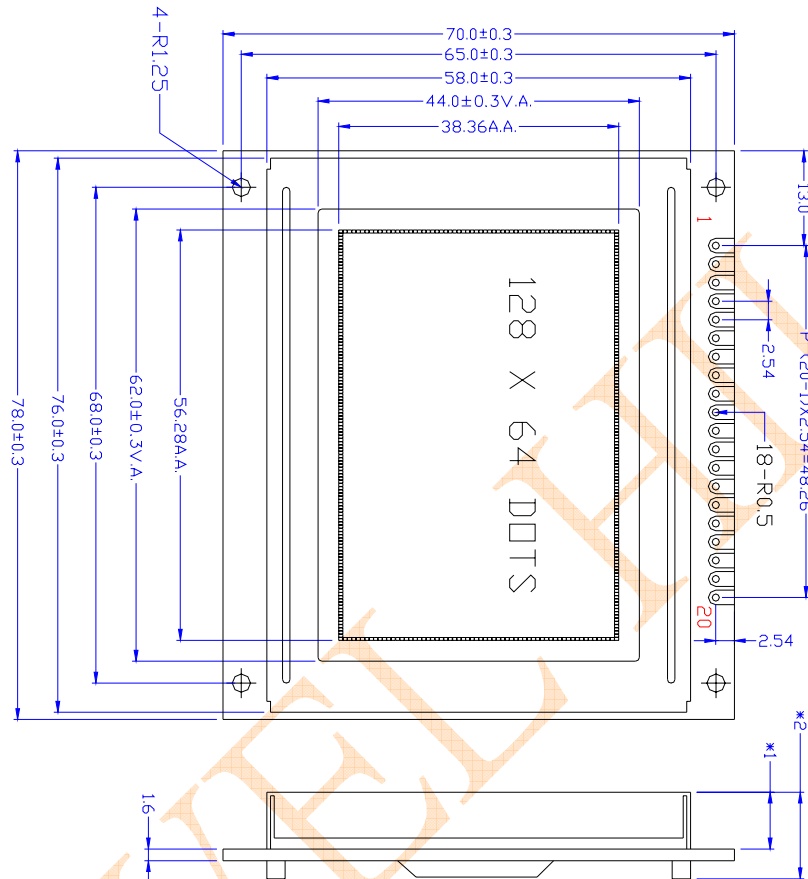

NO.	SYMBOL	NO.	SYMBOL
1	FG/V _{EE}	11	DB1
2	V _{SS}	12	DB2
3	V _{DD}	13	DB3
4	V _O	14	DB4
5	WR	15	DB5
6	RD	16	DB6
7	CE	17	DB7
8	CD	18	FS
9	RES	19	LEDK
10	DB0	20	LEDA

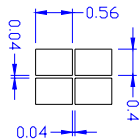

TYPE	*1	*2
R&BL	--	--
LED	7.8	12.0

5. MAXIMUM RATINGS

Item	Symbol	Min	Max	Unit	Note
Supply voltage	$V_{DD} - V_{SS}$	-0.3	7.0	V	
	$V_{DD} - V_{EE}$	-0.3	14.0	V	
Input Voltage	V_{IN}	-0.3	$V_{DD}+0.3$	V	
Operating temperature	T_{OPR}	-30	+70	°C	
Storage temperature	T_{STR}	-40	+80	°C	
Humidity	---	---	90	%RH	

6. ELECTRICAL CHARACTERISTICS

Item		Symbol	Condition	Min.	Typ.	Max.	Unit
Supply Voltage	Logic	V_{DD}	---	---	5.0	5.5	V
Input Voltage	H level	V_{IH}	---	$0.8V_{DD}$	---	V_{DD}	V
	L level	V_{IL}		V_{SS}	---	$0.2V_{DD}$	
Current Consumption (LCD DRIVER)		I_{DD}	$V_{DD}=5.0V;$ $V_{LCD}=9.5V,$ $T_{amb}=25^{\circ}C;$	---	15.0	20.0	mA
LCD Driving Voltage		V_{LCD}	Bias=1/9 $V_{LCD}=V_{DD}-V_0$	9.3	9.5	9.7	V
Power Supply for LED		V_f	$I_f=60mA$	4.8	5.0	5.2	V
Current Consumption (With LED BackLight)		I_f	$V_{DD}=5.0V;$ $V_f=5.0V, T_{amb}=25^{\circ}C;$	---	60	80	mA

7. MODULE FUNCTION DESCRIPTION

7.1. PIN DESCRIPTION

Pin No.	Symbol	Description
1	FG/VEE	Frame Ground
2	VSS	Power supply for Ground (0V)
3	VDD	Power supply for positive (5V)
4	V0	LCD driver voltage regulation pin
5	WR	Write signal input
6	RD	Read signal input
7	CE	Chip selection
8	CD	Command/Data register selection
9	RES	Reset signal input pin, Low level is active
10	DB0	8-bit bi-directional data bus
11	DB1	
12	DB2	
13	DB3	
14	DB4	
15	DB5	
16	DB6	
17	DB7	
18	FS	Font selection
19	LEDK	Power supply voltage for backlight negative
20	LEDA	Power supply voltage for backlight positive

7.2 TIMING CHARACTERISTICS

22.3 Driver clock characteristics

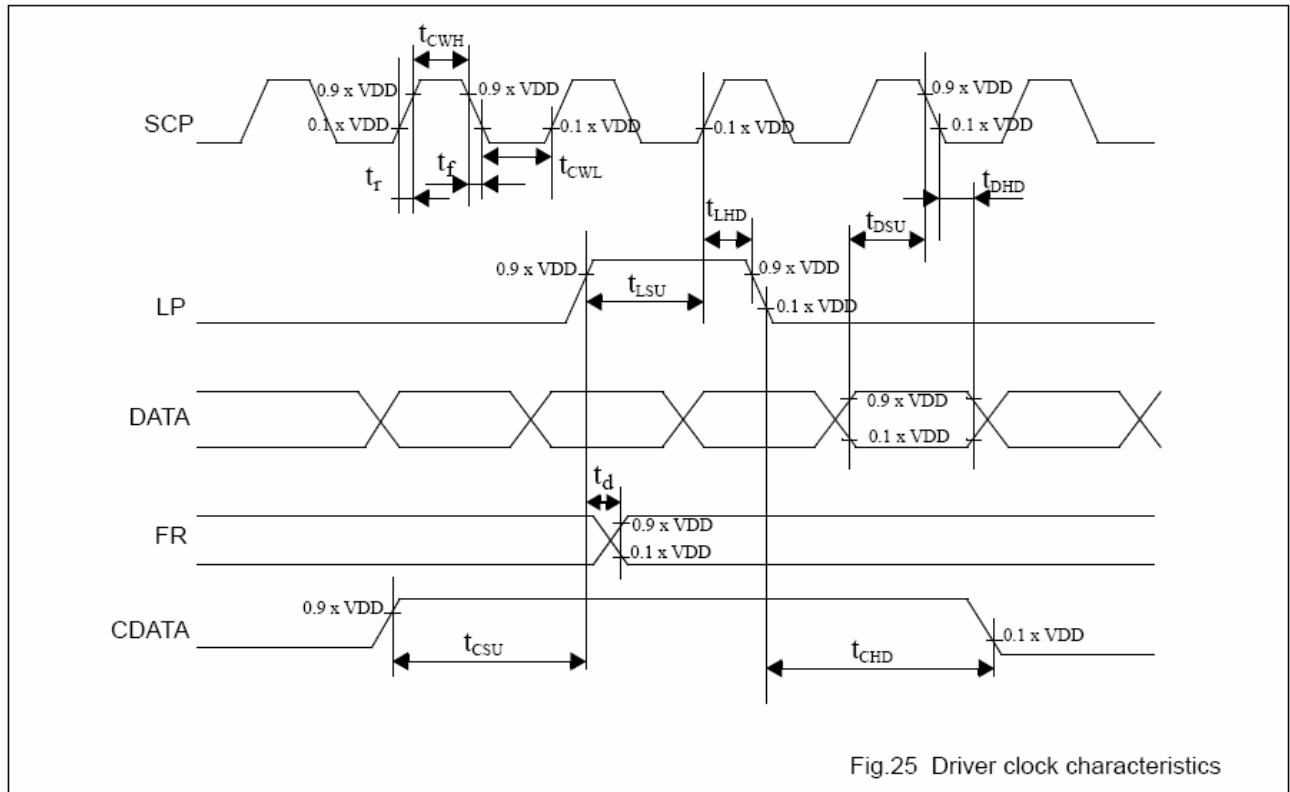

Fig.25 Driver clock characteristics

Table 21 Driver clock characteristics

$V_{DD} = 5 \text{ V} \pm 10\%$; $V_{SS} = 0 \text{ V}$; all voltages with respect to V_{SS} unless otherwise specified; $T_{amb} = -20$ to $+70 \text{ }^\circ\text{C}$.

SYMBOL	PARAMETER	CONDITIONS	MIN.	MAX.	UNIT
f_{SCP}	Operating frequency	$T_{amb} = -10$ to $+70 \text{ }^\circ\text{C}$		2.75	MHz
T_{CWH}, T_{CWL}	SCP pulse width		150		ns
T_r, T_f	SCP Rise/Fall time			30	ns
t_{LSU}	LP set-up time		150	290	ns
t_{LHD}	LP hold time		5	40	ns
t_{DSU}	Data set-up time		170		ns
t_{DHD}	Data hold time		80		ns
t_d	Frame delay time			90	ns
t_{CSU}	CDATA set-up time		450	850	ns
t_{CHD}	CDATA hold time		450	950	ns

22.4 Microcontroller bus interface timing

Fig.26 Microcontroller bus interface timing

Table 22 Microcontroller interface timing

 $V_{DD} = 5 \text{ V} \pm 10\%$; $V_{SS} = 0 \text{ V}$; $T_{amb} = -20 \text{ }^\circ\text{C}$ to $+70 \text{ }^\circ\text{C}$.

symbol	parameter	MIN.	MAX.	test conditons	Unit
t_{CDS}	C/D set-up time	100			ns
t_{CDH}	C/D hold time	10			ns
t_{RD}, t_{WR}	RD, WR pulse width	80			ns
t_{AS}	Address set-up time	0			ns
t_{AH}	Address hold time	0			ns
t_{DS}	Data set-up time	80			ns
t_{DH}	Data hold time	40		Note	ns
t_{ACC}	Access time		150	Note	ns
t_{OH}	Output hold time	10	50	Note	ns

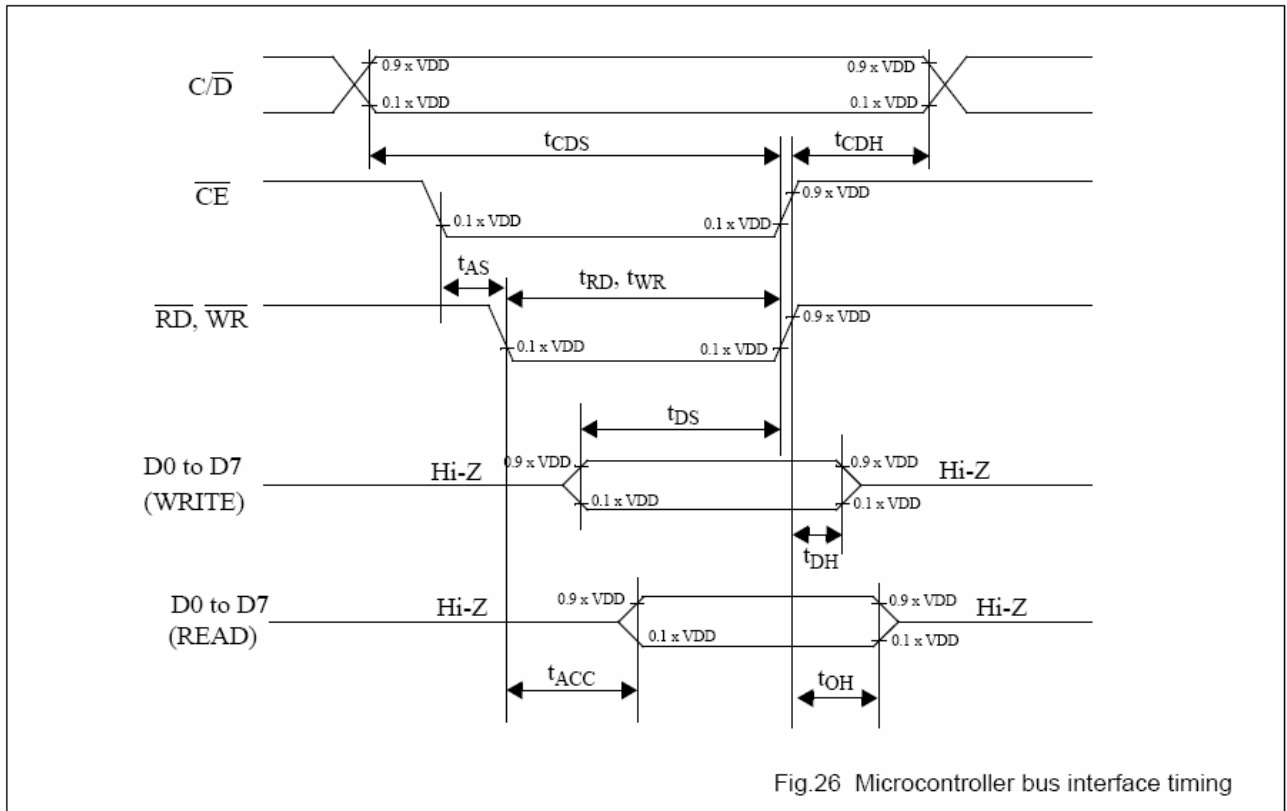
Note:

The measurement is with the load circuit connected.

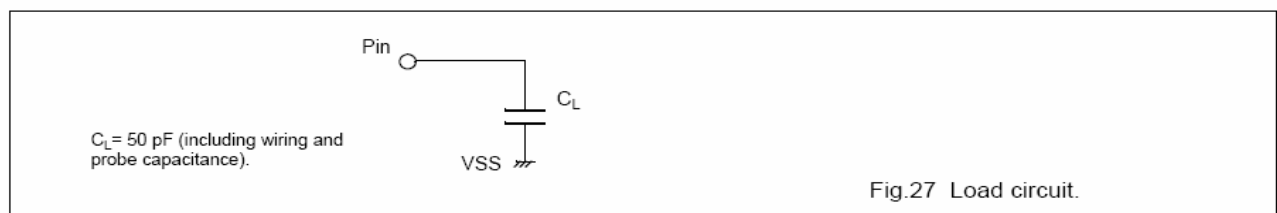
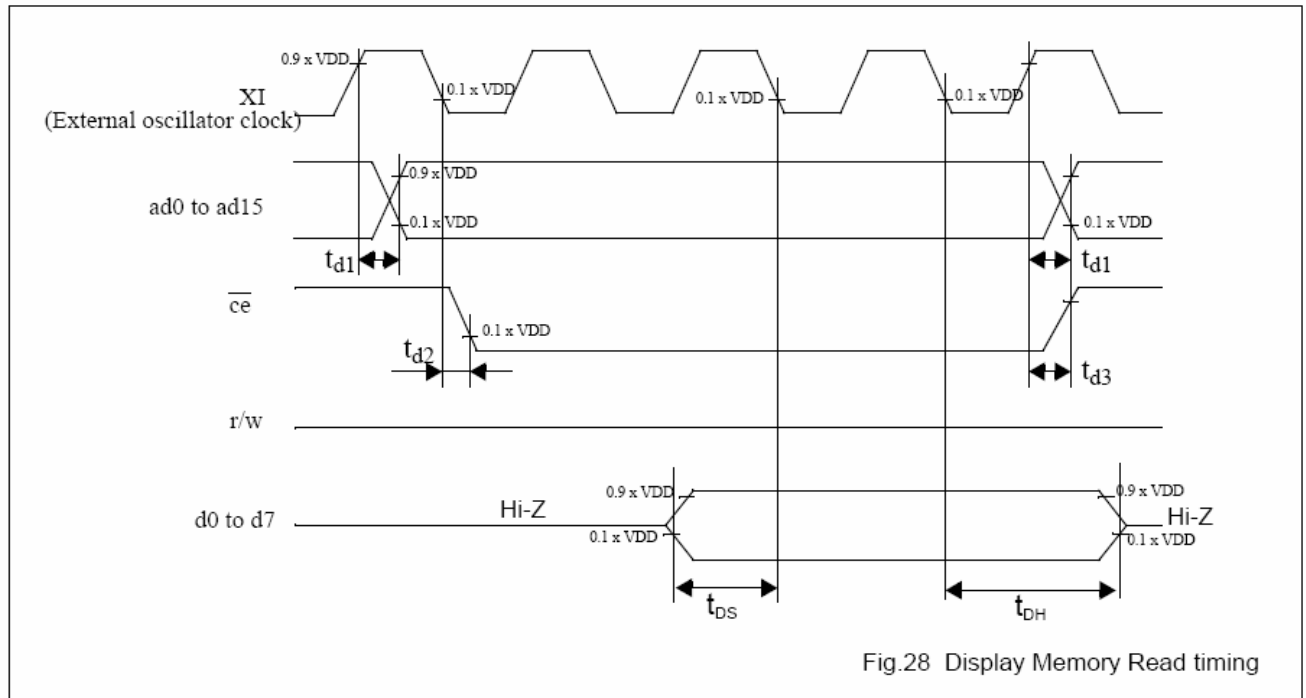

Fig.27 Load circuit.

22.5 Display Memory Read/Write Timing

22.5.1 DISPLAY MEMORY READ TIMING



22.5.2 DISPLAY MEMORY WRITE TIMING

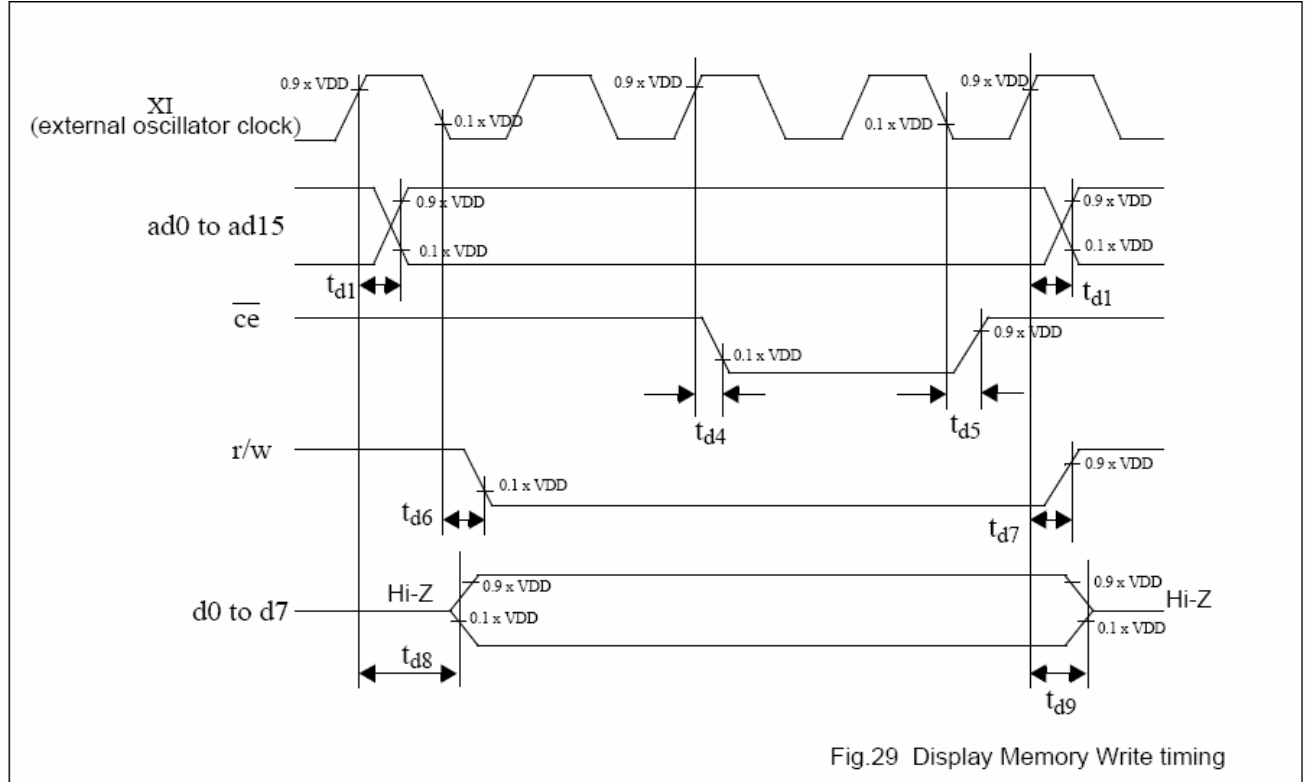

Table 23 Switching characteristics (3)

$V_{DD} = 5\text{ V} \pm 10\%$; $V_{SS} = 0\text{ V}$; $T_{amb} = -20\text{ }^{\circ}\text{C}$ to $+70\text{ }^{\circ}\text{C}$.

symbol	parameter	MIN.	MAX.	test condition	unit
t_{d1}	Address delay time		250		ns
t_{d2}	\overline{ce} fall delay time (Read)		180		ns
t_{d3}	\overline{ce} rise delay time (Read)		180		ns
t_{DS}	Data set-up time	0			ns
t_{DH}	Data hold time	30			ns
t_{d4}	\overline{ce} fall delay time (Write)		200		ns
t_{d5}	\overline{ce} rise delay time (Write)		200		ns
t_{d6}	r/w fall delay time		180		ns
t_{d7}	r/w rise delay time		180		ns
t_{d8}	Data stable time		450	Refer to Fig.27 for measuring condition.	ns
t_{d9}	Data hold time		200		ns

7.3 APPLICATION OF LCM

■Circuit Block Diagram

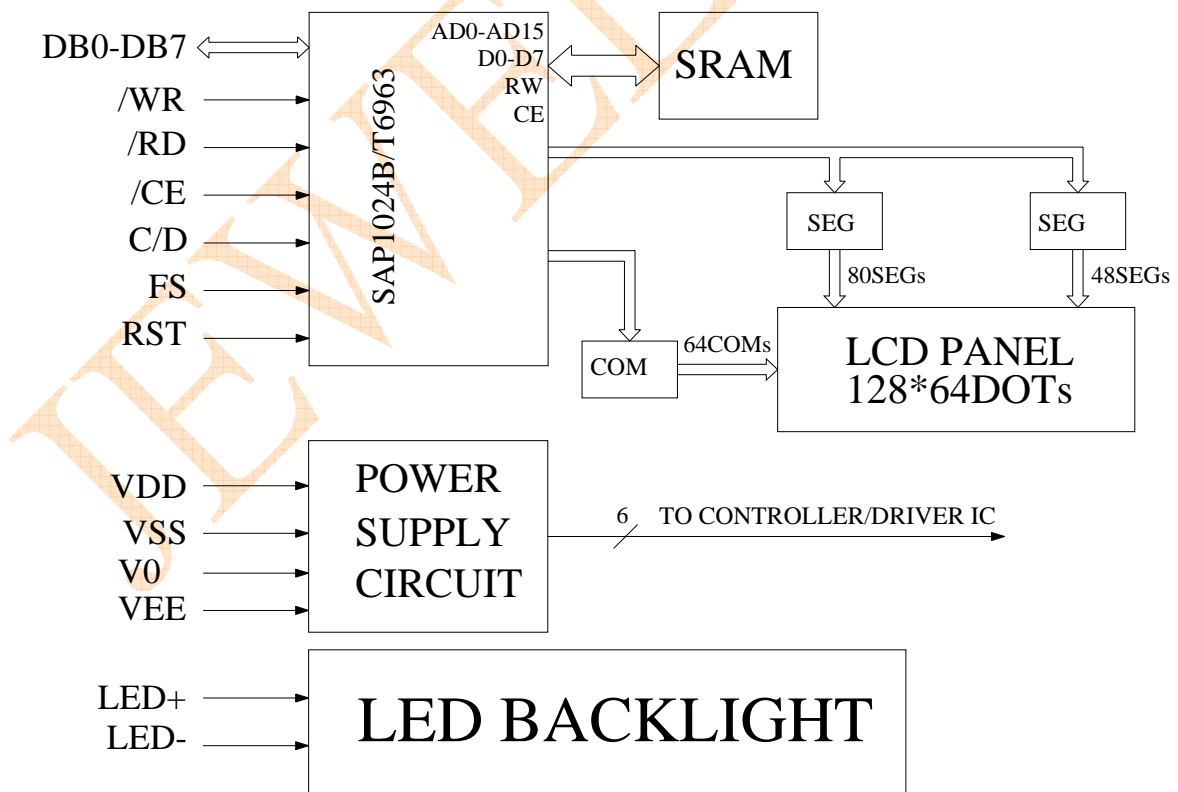

7.4 TABLE OF COMMAND

Command	Code	D1	D2	Function
REGISTERS SETTING	00100001 00100010 00100100	X address Data Low address	Y address 00H High address	Set Cursor Pointer Set Offset Register Set Address Pointer
SET CONTROL WORD	01000000 01000001 01000010 01000011	Low address Columns Low address Columns	High address 00H High address 00H	Set Text Home Address Set Text Area Set Graphic Home Address Set Graphic Area
MODE SET	1000X000 1000X001 1000X011 1000X100 10000XXX 10001XXX	— — — — — —	— — — — — —	OR mode EXOR mode AND mode Text Attribute mode Internal CG ROM mode External CG RAM mode
DISPLAY MODE	10010000 1001XX10 1001XX11 100101XX 100110XX 100111XX	— — — — — —	— — — — — —	Display off Cursor on, blink off Cursor on, blink on Text on, graphic off Text off, graphic on Text on, graphic on
CURSOR PATTERN SELECT	10100000 10100001 10100010 10100011 10100100 10100101 10100110 10100111	— — — — — — — —	— — — — — — — —	1-line cursor 2-line cursor 3-line cursor 4-line cursor 5-line cursor 6-line cursor 7-line cursor 8-line cursor
DATA AUTO READ / WRITE	10110000 10110001 10110010	— — —	— — —	Set Data Auto Write Set Data Auto Read Auto Reset
DATA READ / WRITE	11000000 11000001 11000010 11000011 11000100 11000101	Data — Data — Data —	— — — — — —	Data Write and Increment ADP Data Read and Increment ADP Data Write and Decrement ADP Data Read and Decrement ADP Data Write and Nonvariable ADP Data Read and Nonvariable ADP
SCREEN PEEK	11100000	—	—	Screen Peek
SCREEN COPY	11101000			Screen Copy
BIT SET / RESET	11110XXX 11111XXX 1111X000 1111X001 1111X010 1111X011 1111X100 1111X101 1111X110 1111X111	— — — — — — — — — —	— — — — — — — — — —	Bit Reset Bit Set Bit 0 (LSB) Bit 1 Bit 2 Bit 3 Bit 4 Bit 5 Bit 6 Bit 7 (MSB)

X: invalid

7.5 RAM INTERFACE

7 EXTERNAL DISPLAY MEMORY

The external Display Memory must be static RAM. It is for storing text data, graphic data, external user-defined Character Generator (CG) fonts, and attribute data for text display. Memory for attribute data of text display can overlap with or reside in graphic area.

In single-scan application, text data, graphic data, attribute data, and external user-defined CG data can be freely allocated to the whole memory space of the Display Memory (maximum 64K).

In dual-scan application, the memory area for LCD1 is allocated to the space from 0000H to 7FFFH (32K bytes, maximum) and that for LCD2 is allocated to the space from 8000H to FFFFH (32K bytes, maximum). Text data, graphic data, and CG data can be freely allocated to any area of the memory space in LCD1. In LCD2, the corresponding memory regions, as that for the LCD1, must be allocated to the text area, graphic area, and the Character Generator RAM, except address bit ad15. Address bit ad15 can be used in the address decoding circuit to distinguish LCD1 from LCD2. ad15=L selects LCD1 and ad15=H selects LCD2.

Two signals, $\overline{ce0}$ and $\overline{ce1}$, can be used to help decoding memory blocks with 4K boundary. $\overline{ce0}$ can be used to decode memory block in the range from 0000H to 07FFFH. $\overline{ce1}$ can be used to decode memory blocks in the range from 0800H to 0FFFFH.

An example of memory space allocation is given below:

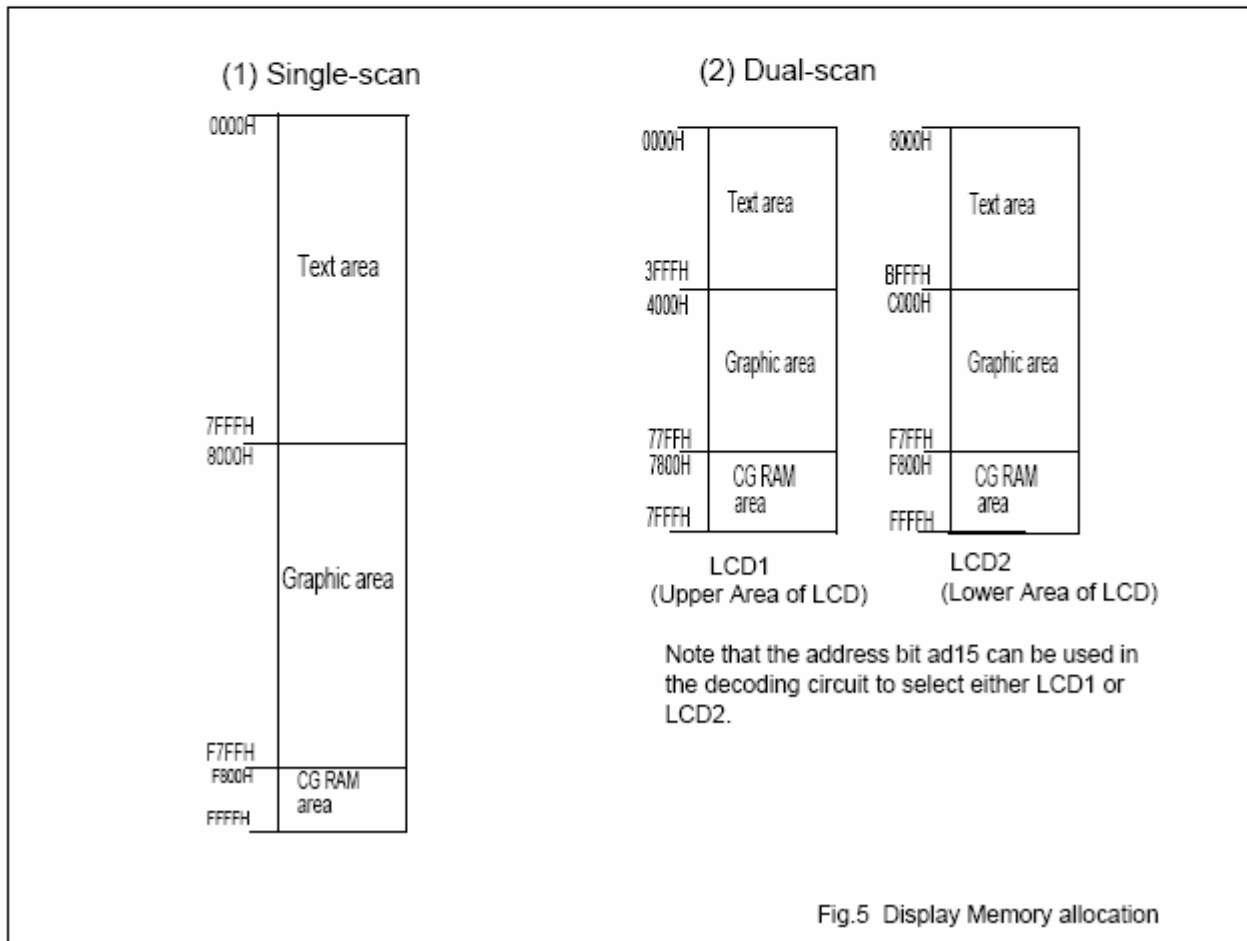

7.6 FLOWCHART OF COMMUNICATION WITH MPU

8.1 READ/WRITE operation to the SAP1024B

A microcontroller can write command to the SAP1024B or read status from it. A microcontroller can do Read/Write operation to the Display Memory, via SAP1024B.

Data or commands are put on the data bus D0~D7. Inside the SAP1024B, there is an latch for each bit of D0~D7.

The operations between the host microcontroller and the SAP1024B are: Write Data, Read Data, Write Command, and Read Status. It is the host microcontroller's responsibility to put proper control signals and timing on the control bus for these Read/Write operation.

Table 5 gives control signal setting.

Table 5 Read/Write operation between the host microcontroller and the SAP1024B

Operation	Description
Write Data to the Display Memory	<ol style="list-style-type: none"> 1. The data to be written should be put on D0~D7. 2. $\overline{C/D}$ should be set to low. 3. \overline{WR} should be set to low. 4. \overline{RD} should be set to high. 5. \overline{CE} should be set to low.
Read Data from the Display Memory	<ol style="list-style-type: none"> 1. $\overline{C/D}$ should be set to low. 2. \overline{WR} should be set to high. 3. \overline{RD} should be set to low. 4. \overline{CE} should be set to low. 5. The data appears on D0~D7.
Write Command to the SAP1024B	<ol style="list-style-type: none"> 1. The command to be written should be put on D0~D7. 2. $\overline{C/D}$ should be set to high. 3. \overline{WR} should be set to low. 4. \overline{RD} should be set to high. 5. \overline{CE} should be set to low.
Read Status from the SAP1024B	<ol style="list-style-type: none"> 1. $\overline{C/D}$ should be set to high. 2. \overline{WR} should be set to high. 3. \overline{RD} should be set to low. 4. \overline{CE} should be set to low. 5. The status of the SAP1024B appears on D0~D7.

9 STATUS CHECK

The system microcontroller must perform a status check before writing data to or reading data from the SAP1024B. The purpose of status check is to make sure that the SAP1024B has finished previous command or operation and is ready to accept new command or data.

9.1 Status Register

To read the status of the SAP1024B, the host microcontroller must set the control bus to the proper states, as described in Table 5. The content of Status Register appears on D0~D7.

The format of the Status Register is given in table 6.

Table 6 Status Register format

D7(MSB)	D6	D5	D4	D3	D2	D1	D0(LSB)
STA7	STA6	STA5	STA4	STA3	STA2	STA1	STA0

Table 7 Description of Status Register bits

BIT	SYMBOL	FUNCTION
D0	STA0	Command flag. STA0=0 indicates that the SAP1024B is busy and can not accept new command. STA0=1 indicates that the SAP1024B is ready for accepting new command.
D1	STA1	Data Read/Write flag. STA1=0 indicates that the SAP1024B is busy and can not accept data read/write request. STA1=1 indicates that the SAP1024B is ready for accepting data/read/write request.
D2	STA2	Auto Data Read flag. STA2=0 indicates that the SAP1024B is busy and can not accept Auto Data Read request. STA2=1 indicates that the SAP1024B is ready for accepting Auto Data Read request.
D3	STA3	Auto Data Write flag. STA3=0 indicates that the SAP1024B is busy and can not accept Auto Data Write request. STA3=1 indicates that the SAP1024B is ready for accepting Auto Data Write request.
D4	STA4	Reserved.

BIT	SYMBOL	FUNCTION
D5	STA5	Check controller operation capability. 0= Disabled, 1= Enabled.
D6	STA6	Error flag. This command is used for commands SCREEN PEAK or SCREEN COPY. STA6=0 indicates that Address Pointer is valid and that there is no error. STA6=1 indicates that Address Pointer is out of Graphic RAM area.
D7	STA7	Blink flag. Check the blink status. 0=blinking area of display off, 1= blinking area of display on.

Note:

1. STA0 and STA1 must be checked at the same time. If a hardware interrupt occurs to the microcontroller during the check, the status on the data bus D0~D7 may not be correct.
2. For most modes, STA0 and STA1 are used as status check.
3. In AUTO READ/WRITE mode, STA2 and STA3 indicates the real status of the SAP1024B. STA0 and STA1 do not indicates the real status of the SAP1024B in AUTO READ/WRITE mode.

9.2 Status check flowchart

Fig. 6 gives flow charts for writing status check subroutines.

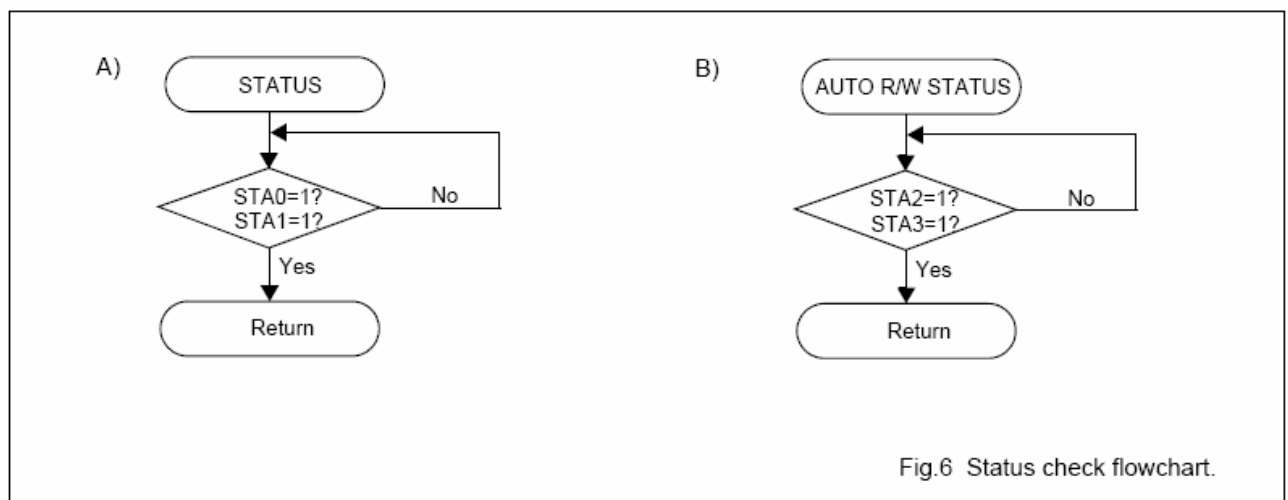

Fig.6 Status check flowchart.

Note the following:

- Status check must be performed prior to issuing a MSB=0 command. If a status check is not performed, there is danger that the SAP1024B may not work properly, even after a delayed period of time.
- A hardware interrupt to the microcontroller may occur during the address calculation period (at the end of each line). If a MSB=0 command is sent to the SAP1024B during this period of time, it enters into Wait status.
- If a command is issued during Wait status, there is danger that command or data may not be received by the SAP1024B.

8. ELECTRO-OPTICAL CHARACTERISTICS

Item	Symbol	Condition	Temp	Min	Typ.	Max	Units	Note
LCD driving voltage	V _{LCD}	$\theta = \phi = 0$	0°C	---	9.7	---	V	NOTE1
			25°C	9.3	9.5	9.7		
			50°C	---	9.3	---		
Response Time	Rise Time (Tr)	$\theta = \phi = 0$	0°C	---	---	---	msec	NOTE2
	Decay Time (Tf)			---	---	---		
	Rise Time (Tr)		25°C	---	225	340		
	Decay Time (Tf)			---	240	360		
	Rise Time (Tr)		50°C	---	---	---		
	Decay Time (Tf)			---	---	---		
Contrast Ratio	Cr	$\theta = \phi = 0$	25°C	5	10	---	---	NOTE4

Viewing Angle Range	$\theta (\phi = 0^\circ)$ (6'')	$\phi = 90^\circ$ (3'')	$\phi = 180^\circ$ (12'')	$\phi = 270^\circ$ (9'')	備註
$\theta (25^\circ\text{C})$ CR \geq 2	20	25	40	25	Deg NOTE3

● For panel only

• **Electro-Optical Characteristics Measuring Equipment(DMS501)**

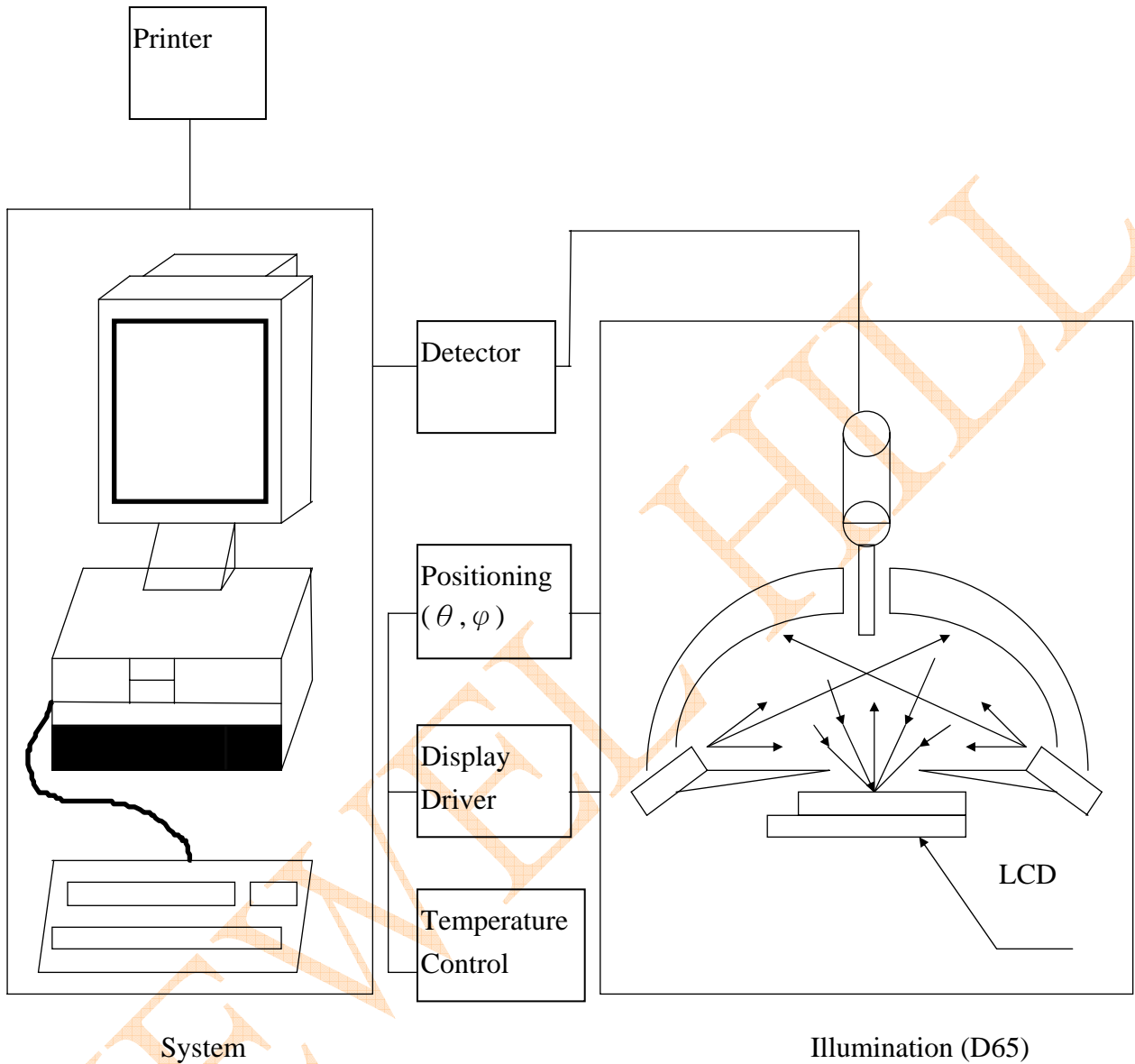

• **Note 1. Definition of Driving Voltage(Vlcd) :**

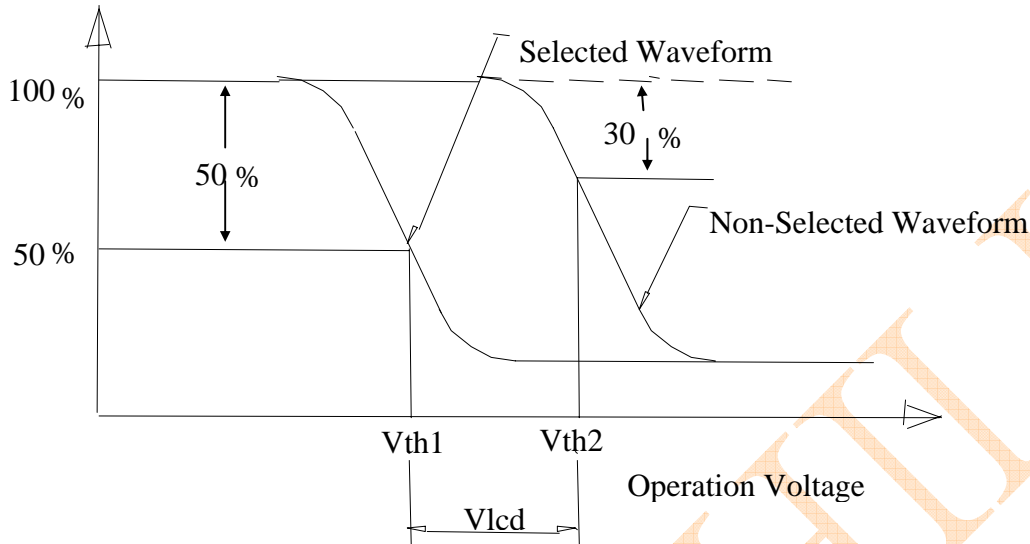

• **Note 2. Definition of Optical Response Time :**

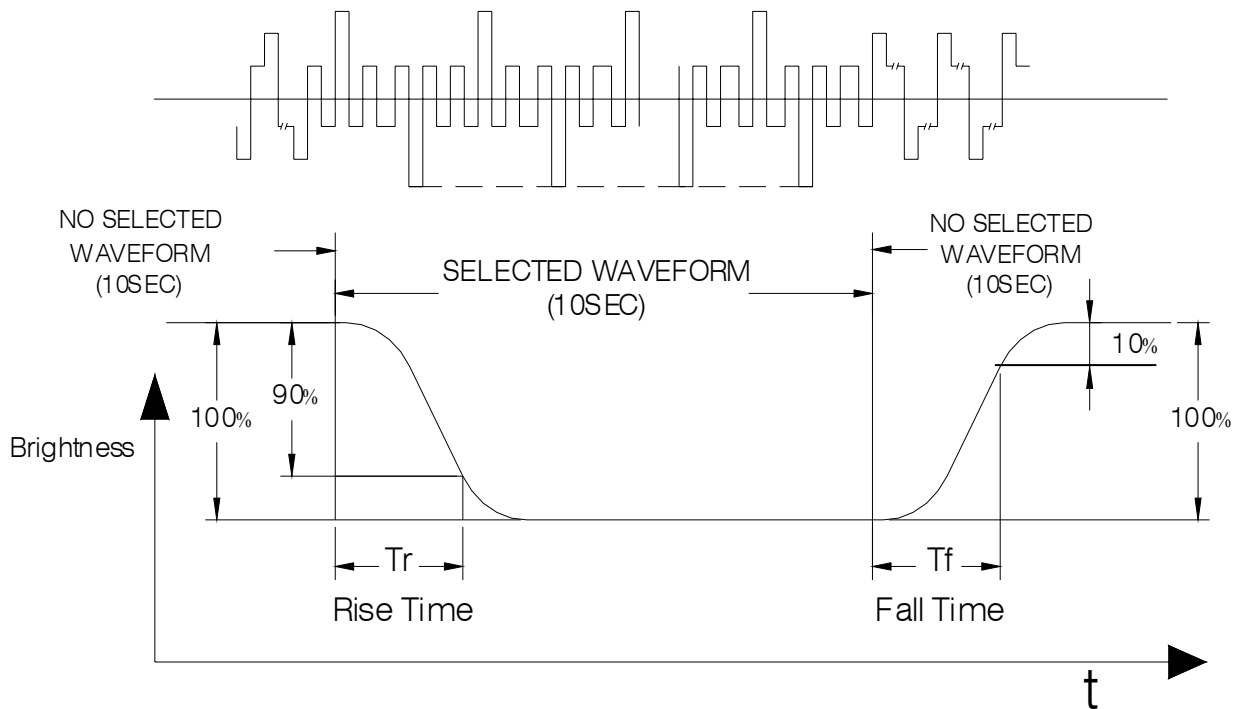

• **Note 3. Definition of Viewing Angle θ and ϕ :**

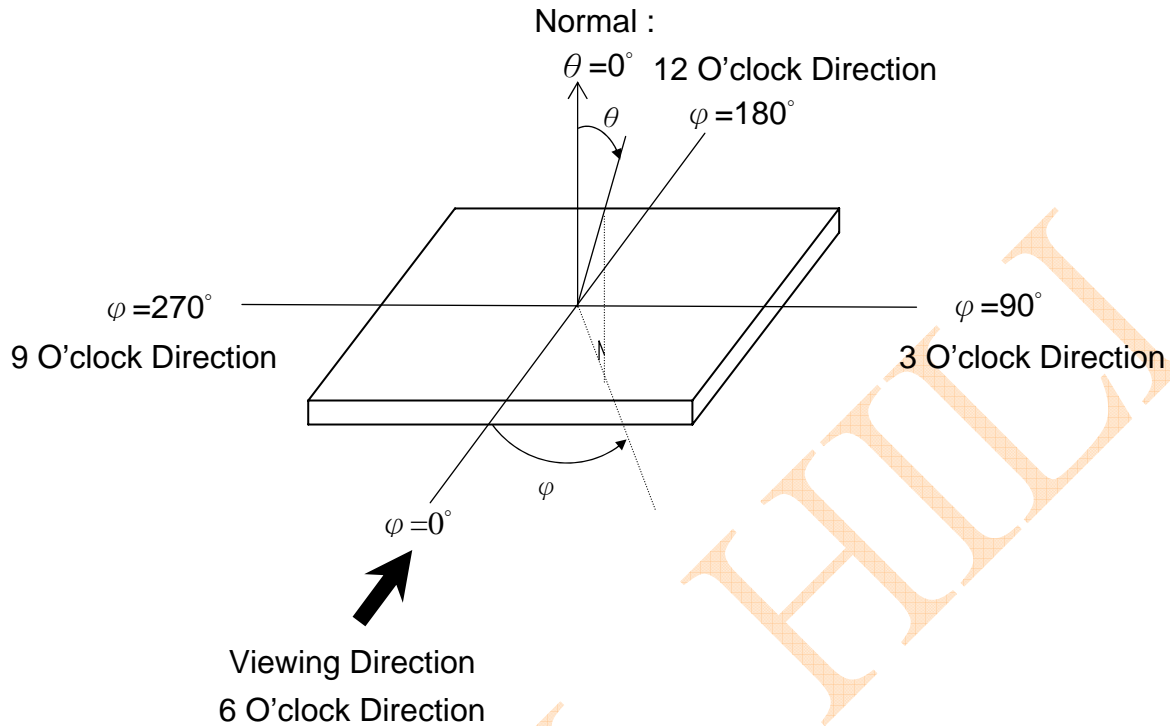

• **Note 4. Definition of Contrast ratio(CR) :**

$$CR = \frac{\text{Brightness of Non-selected Segment (B2)}}{\text{Brightness of Selected Segment (B1)}}$$

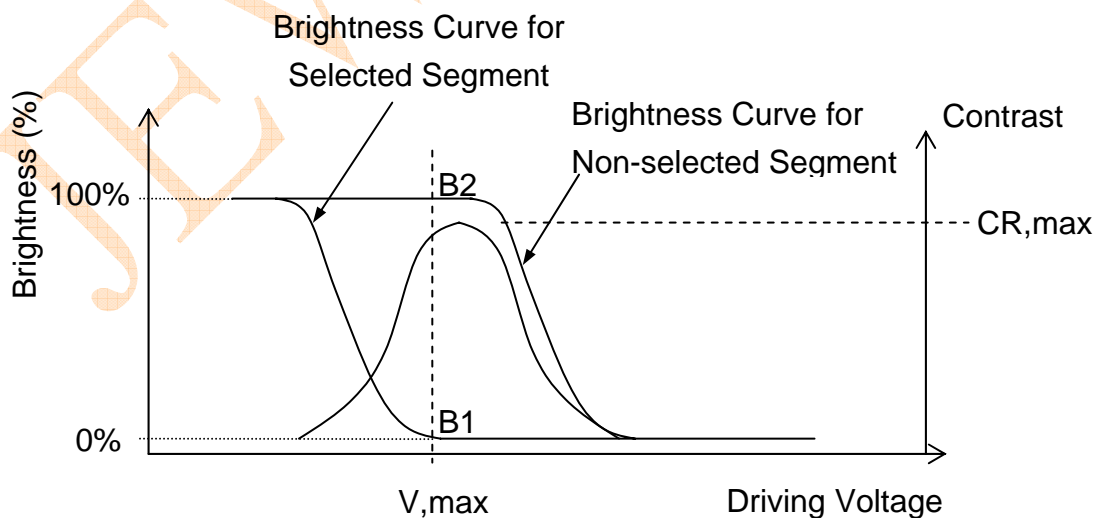

9. RELIABILITY

9.1. MTBF

The LCD module shall be designed to meet a minimum MTBF value of 30000 hours with normal. (25°C in the room without sunlight)

9.2. TESTS

NO.	ITEM	CONDITION	CRITERION
1	High Temperature Operating	70°C 120Hrs	<ul style="list-style-type: none"> ◦ No Defect Of Operational Function In Room Temperature Are Allowable. ◦ IDD of LCM in Pre-and post-test should follow specification
2	Low Temperature Operating	-30°C 120Hrs	
3	High Temperature/ Humidity Non-Operating	60°C ,90%RH ,120 Hrs	
4	High Temperature Non-Operating	80°C 120Hrs	
5	Low Temperature Non-Operating	-40°C 120Hrs	
6	Temperature Cycling Non-Operating	-20°C (30Min)↔ 60°C (30Min) 10 CYCLES	

Notes: Judgments should be made after exposure in room temperature for two hours.

10. PRECAUTIONS FOR USING LCD MODULES

10.1. HANDLING PRECAUTIONS

- (1) The display panel is made of glass. Do not subject it to a mechanical shock or impact by dropping it.
- (2) If the display panel is damaged and the liquid crystal substance leaks out, be sure not to get any in your mouth. If the substance contacts your skin or clothes, wash it off using soap and water.
- (3) Do not apply excessive force to the display surface or the adjoining areas since this may cause the color tone to vary.
- (4) The polarizer covering the display surface of the LCD module is soft and easily scratched. Handle this polarizer carefully.
- (5) If the display surface becomes contaminated, breathe on the surface and gently wipe it with a soft dry cloth. If it is heavily contaminated, moisten a cloth with one of the following solvents:
 - Isopropyl alcohol
 - Ethyl alcohol
- (6) Solvents other than those above mentioned may damage the polarizer.
Especially, do not use the following:
 - Water
 - Ketone
 - Aromatic solvents
- (7) Extra care to minimize corrosion of the electrode. Water droplets, moisture condensation or a current flow in a high-humidity environment accelerates corrosion of the electrode.
- (8) Install the LCD Module by using the mounting holes. When mounting the LCD Module, make sure it is free of twisting, warping and distortion. In particular, do not forcibly pull or bend the I/O cable or the backlight cable.
- (9) Do not attempt to disassemble or process the LCD Module.
- (10) NC terminal should be open. Do not connect anything.
- (11) If the logic circuit power is off, do not apply the input signals.
- (12) To prevent destruction of the elements by static electricity, be careful to maintain an optimum work environment.
 - Be sure to ground the body when handling the LCD Module.
 - Tools required for assembling, such as soldering irons, must be properly grounded.
 - To reduce the amount of static electricity generated, do not conduct assembling and other work under dry conditions.

-The LCD Module is coated with a film to protect the display surface. Exercise care when peeling off this protective film since static electricity may be generated.

10.2. STORAGE CONDITIONS

When storing, avoid the LCD module to be exposed to direct sunlight of fluorescent lamps. For stability, to keep it away from high temperature and high humidity environment (The best condition is : $23\pm 5^{\circ}\text{C}$, $45\pm 20\%\text{RH}$). ESD protection is necessary for long-term storage also.

10.3. OTHERS

Liquid crystals solidify under low temperature (below the storage temperature range) leading to defective orientation or the generation of air bubbles (black or white). Air bubbles may also be generated if the module is subject to a low temperature.

If the LCD Module have been operating for a long time showing the same display patterns the display patterns may remain on the screen as ghost images and a slight contrast irregularity may also appear. A normal operating status can be recovered by suspending use for some time. It should be noted that this phenomenon does not adversely affect performance reliability.

To minimize the performance degradation of the LCD Module resulting from destruction caused by static electricity etc. exercise care to avoid holding the following sections when handling the modules.

- Exposed area of the printed circuit board.
- Terminal electrode sections.

11. Using LCD modules

11.1 LIQUID CRYSTAL DISPLAY MODULES

LCD is composed of glass and polarizer. Pay attention to the following items when handling.

- (1) Please keep the temperature within specified range for use and storage. Polarization degradation, bubble generation or polarizer peel-off may occur with high temperature and high humidity.
- (2) Do not touch, push or rub the exposed polarizers with anything harder than a HB pencil lead (glass, tweezers, etc).
- (3) N-hexane is recommended for cleaning the adhesives used to attach front/rear polarizers and reflectors made of organic substances, which will be damaged by chemicals such as acetone, toluene, ethanol and isopropyl alcohol.
- (4) When the display surface becomes dusty, wipe gently with absorbent cotton or other soft material like chamois soaked in petroleum ether. Do not scrub hard to avoid damaging the display surface.
- (5) Wipe off saliva or water drops immediately, contact with water over a long period of time may cause deformation or color fading.
- (6) Avoid contacting oil and fats.
- (7) Condensation on the surface and contact with terminals due to cold will damage, stain or polarizers. After products are tested at low temperature they must be warmed up in a container before coming in contact with room temperature air.
- (8) Do not put or attach anything on the display area to avoid leaving marks on.
- (9) Do not touch the display with bare hands. This will stain the display area and degrade insulation between terminals (some cosmetics are determinate to the polarizers).
- (10) As glass is fragile, it tends to become or chipped during handling especially on the edges. Please avoid dropping or jarring.

11.2 INSTALLING LCD MODULE

Attend to the following items when installing the LCM.

- (1) Cover the surface with a transparent protective plate to protect the polarizer and LC cell.
- (2) When assembling the LCM into other equipment, the spacer to the bit between the LCM and the fitting plate should have enough height to avoid causing stress to the module surface, refer to the individual specifications for measurements. The measurement tolerance should be ± 0.1 mm.

11.3 ELECTRO-STATIC DISCHARGE CONTROL

Since this module uses a CMOS LSI, the same careful attention should be paid for electrostatic discharge as for an ordinary CMOS IC.

- (1) Make certain that you are grounded when handling LCM.
- (2) Before removing LCM from its packing case or incorporating it into a set, be sure the module and your body have the same electric potential.
- (3) When soldering the terminal of LCM, make certain the AC power source for the soldering iron does not leak.
- (4) When using an electric screwdriver to attach LCM, the screwdriver should be of ground potentiality to minimize as much as possible any transmission of electromagnetic waves produced sparks coming from the commutator of the motor.
- (5) As far as possible, make the electric potential of your work clothes and that of the workbenches to the ground potential.
- (6) To reduce the generation of electro-static discharge, be careful that the air in the work is not too dried. A relative humidity of 50%-60% is recommended.

11.4 PRECAUTIONS FOR OPERATION

- (1) Viewing angle varies with the change of liquid crystal driving voltage (V_o). Adjust V_o to show the best contrast.
- (2) Driving the LCD in the voltage above the limit will shorten its lifetime.
- (3) Response time is greatly delayed at temperature below the operating temperature range. However, this does not mean the LCD will be out of the order. It will recover when it returns to the specified temperature range.
- (4) If the display area is pushed hard during operation, the display will become abnormal. However, it will return to normal if it is turned off and then on.
- (5) Condensation on terminals can cause an electrochemical reaction disrupting the terminal circuit. Therefore, this product must be used and stored within the specified condition of $23\pm 5^{\circ}\text{C}$, $45\pm 20\% \text{RH}$.
- (6) When turning the power on, input each signal after the positive/negative voltage becomes stable.

11.5 SAFETY

- (1) It is recommended to crush damaged or unnecessary LCDs into pieces and wash them off with solvents such as acetone and ethanol, which should later be burned.
- (2) If any liquid leaks out of a damaged glass cell and comes in contact with the hands, wash off thoroughly with soap and water.



SAMPLE APPROVED REPORT (样品确认单)

SAMPLE MODEL NO. (样品型号)	JHB12864G
SAMPLE SERIES NUMBER NO. (样品序号)	
SAMPLE QUANTITY (样品数量)	
COLOR/TYPE (底色/类型)	STN/BLUE/NEGATIVE
VIEWING DIRECTION (视角)	6:00
DRIVING METHOD (驱动参数)	1/64Duty, 1/9Bias
LOGIC VOLTAGE (工作电压)	5.0V
LCD VOP (LCD 驱动电压)	9.5V
OPERATING TEMP. (操作温度)	-30 ~ 70℃
STORAGE TEMP. (储存温度)	-40 ~ 80℃
POLARIZER MODE (偏光片模式)	TRANSMISSIVE
CONTROLLER/DRIVER IC(控制/驱动 IC)	SAP1024B/SDN8080
BACKLIGHT COLOR/TYPE (背光源类型/颜色)	LED/WHITE
DRAWING REV/NO./QUANTITY (图纸版本/数量)	
SPECIFICATION (规格书 份数)	
REMARKS: (备注)	
WRIT BY: _____ DATE: _____ APROV BY: _____ DATE: _____	
CUSTOMER'S APPROVAL (客户确认):	
1) FUNCTION (功能):	<input type="checkbox"/> OK <input type="checkbox"/> N.G.
2) DRIVER CONDITION (驱动条件):	<input type="checkbox"/> OK <input type="checkbox"/> N.G.
3) DISPLAY MODE (显示模式):	<input type="checkbox"/> OK <input type="checkbox"/> N.G.
4) VIEWING ANGLE (视角):	<input type="checkbox"/> OK <input type="checkbox"/> N.G.
5) BACKLIGHT (背光源):	<input type="checkbox"/> OK <input type="checkbox"/> N.G.
6) DISPLAYING PATTERN (显示效果):	<input type="checkbox"/> OK <input type="checkbox"/> N.G.
CUSTOMER'S CONCLUSIONS (客户意见): _____	

CUSTOMER'S SIGNATURE (客户签名): _____ DATE (日期): _____	