

# ATS137

## Single Hall Effect Switch

### ■ Features

- 3.5V to 20V DC operation voltage
- Temperature compensation
- Wide operating voltage range
- Open-Collector pre-driver
- 25mA maximum sinking output current.
- Reverse Polarity Protection
- 

### ■ Applications

- VCD/DVD loader, CD/DVD ROM
- Cover detector
- Speed measurement
- Home appliances
- Home safety

### ■ General Descriptions

ATS137 is an switched Hall-Effect IC which for contactless switching applications. The device includes an on-chip Hall voltage generator for magnetic sensing, an amplifier that amplifies the Hall voltage, a schmitt trigger to provide switching hysteresis for noise rejection, and an open-collector output. The bandgap regulator allows a wide operating voltage range.

ATS137 is rated for operating temperature range from  $-20^{\circ}\text{C}$  to  $85^{\circ}\text{C}$  and voltage range from 3.5V to 20V.

### ■ Order Information

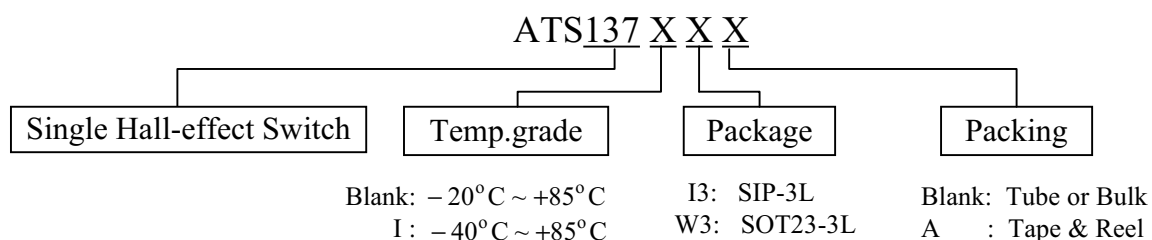

### ■ Typical Circuit

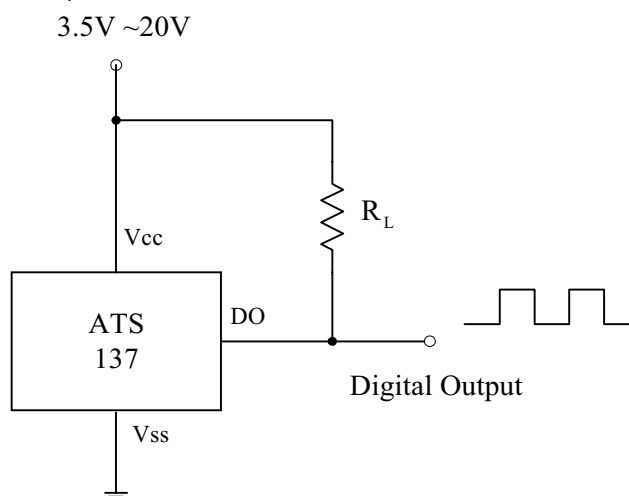

# ATS137

## Single Hall Effect Switch

### ■ Functional Block Diagrams

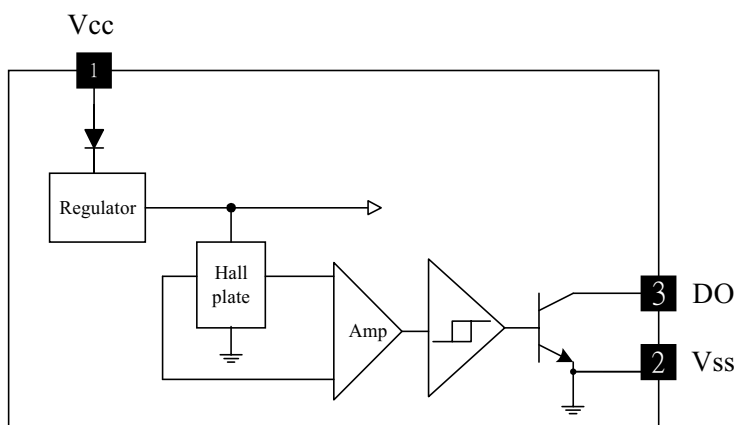

### ■ Pin Descriptions

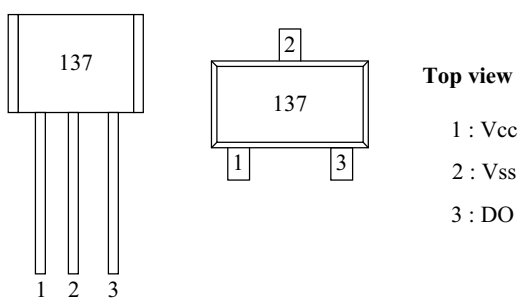

Name	P/I/O	Pin #	Description
Vcc	P	1	Positive Power Supply
Vss	P	2	Ground
DO	O	3	Digital Output

# ATS137

## Single Hall Effect Switch

### ■ Absolute Maximum Ratings ( at Ta= 25°C )

- Supply Voltage, Vcc ..... 20V
- Reverse Vcc Polarity Voltage, V<sub>RCC</sub>..... -20V
- Magnetic flux density, B..... Unlimited
- Output OFF Voltage, Vce ..... 30V
- Output ON Current, Ic (continuous)..... 25mA
- Operating Temperature ( Ta ) ..... -20°C ~ 85°C
- Storage Temperature ( Ts ) ..... -65°C ~ 150°C
- Package Power Dissipation ( Pd ) ..... 400mW (SIP-3L)  
     (Pd)..... 200mW (SOT23-3L)
- Maximum Junction Temp.( Tj ) ..... 175°C

### ■ Electrical Characteristics ( Ta=+ 25°C )

Characteristic	Symbol	Test Conditions	Min	Typ	Max	Units
Supply voltage	Vcc	—	3.5	—	20	V
Output saturation voltage	Vce(sat)	Vcc=14V, Ic=20mA	—	300	700	mV
Output leakage current	Icex	Vce=14V, Vcc=14V	—	<0.1	10	uA
Supply current	Icc	Vcc=20V, Output Open	—	5	10	mA
Output rise time	tr	Vcc=14V, RL=820Ω, CL=20Pf	—	0.3	1.5	us
Output falling time	tf	Vcc=14V, RL=820Ω, CL=20pF	—	0.3	1.5	us

### ■ Magnetic Characteristics ( T<sub>A</sub> = 25 °C , 1mT= 10 Gauss )

Parameter	Symbol	Min.	Max.	Unit
Operate point	Bop	-	10	mT
Release point	Brp	1.5	-	mT
Hysteresis	Bhys	5	20	mT

### ■ Test Circuit

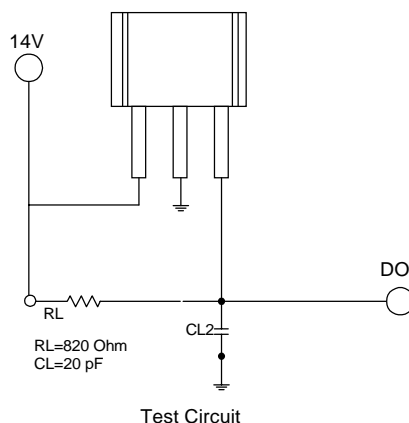

# ATS137

Single Hall Effect Switch

## ■ Package Information

(1). SIP-3L

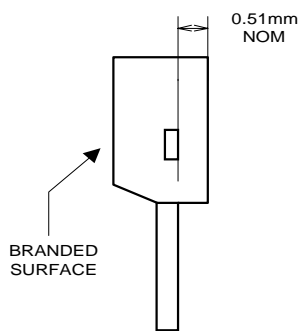

Active Area Depth

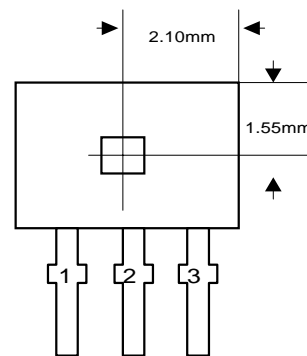

Sensor Location

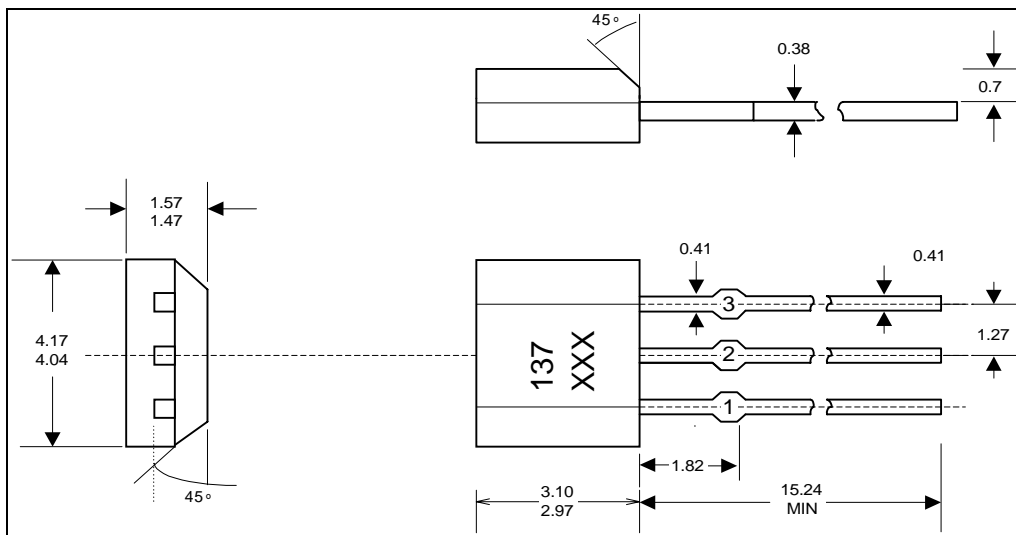

Package Dimension

# ATS137

Single Hall Effect Switch

## ■ Package Information (continued)

(2). SOT23-3L

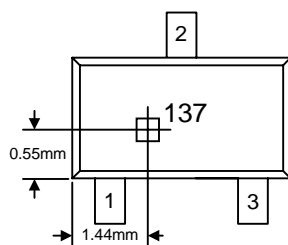

Sensor Location

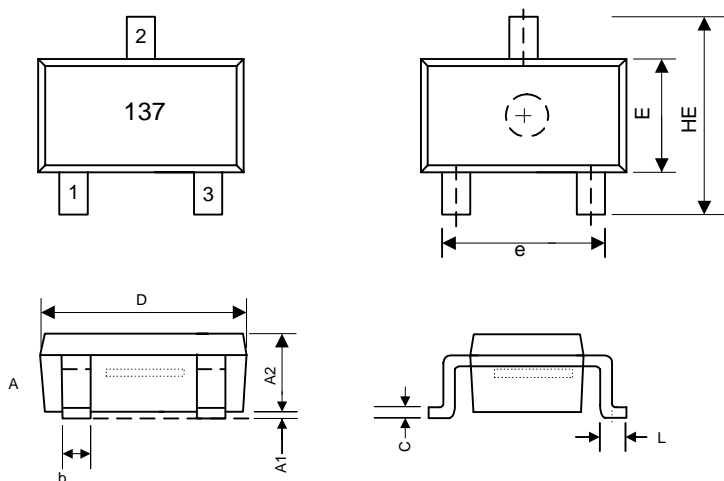

Symbols	Dimensions in Millimeters			Dimensions in inches		
	Min.	Nom.	Max.	Min.	Nom.	Max.
A	0.70	0.80	0.90	0.028	0.031	0.035
A1	0.00	—	0.10	0.000	—	0.004
A2	1.00	1.15	1.30	0.039	0.045	0.051
b	0.35	—	0.50	0.014	—	0.020
C	0.10	0.175	0.25	0.004	0.007	0.010
D	2.70	2.90	3.10	0.106	0.114	0.122
E	1.40	1.60	1.80	0.055	0.063	0.071
e	1.70	1.90	2.10	0.067	0.075	0.083
HE	2.80	2.90	3.00	0.110	0.114	0.118
L	0.35	0.45	0.55	0.014	0.018	0.022

Package Dimension

# ATS137

## Single Hall Effect Switch

### ■ Application Information

#### - Operating principle

ATS137 is a three pins Hall Effect switch IC which can turn magnetic flux variety to digital output signal. In other words, it is an interface from magnetic system to electrical one by Hall effect. The illustrations are shown in Fig.1.

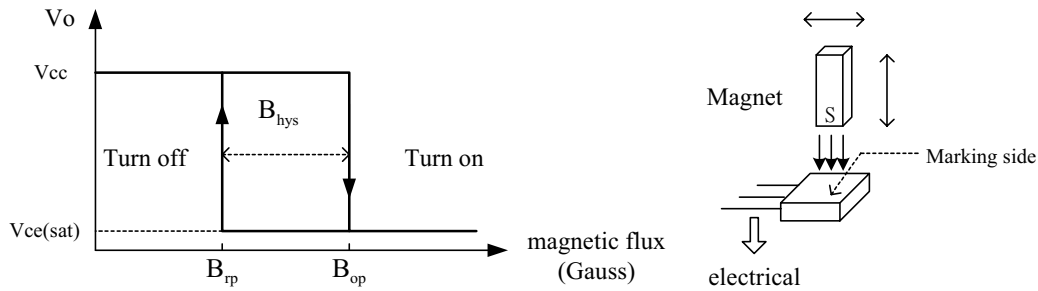

Fig.1 Hall-effect switch

Output driver is open-collector topology and maximum sink current ( $I_{sink}$ ) is 25mA. The illustrated circuit is shown as Fig.2.

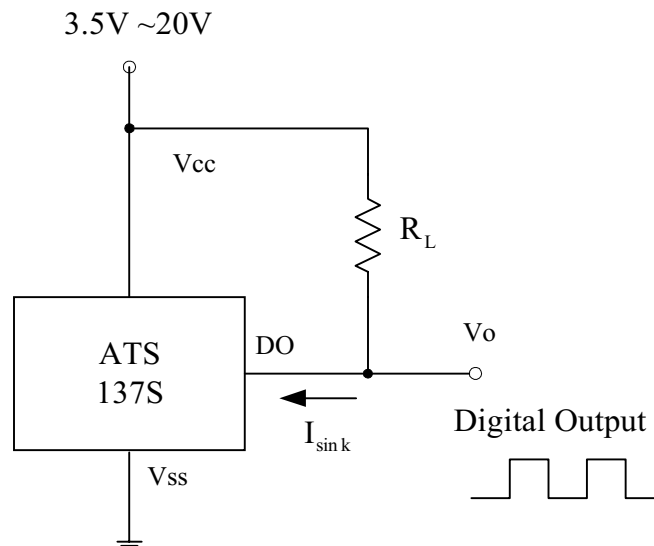

Fig.2 Application circuit

# ATS137

## Single Hall Effect Switch

$V_o$  will turn on (low) if the S magnetic flux larger than operation point (Bop), and turns off whenever the magnetic flux is removed and lower than release point (Brp). The related waveforms are shown in Fig.3.

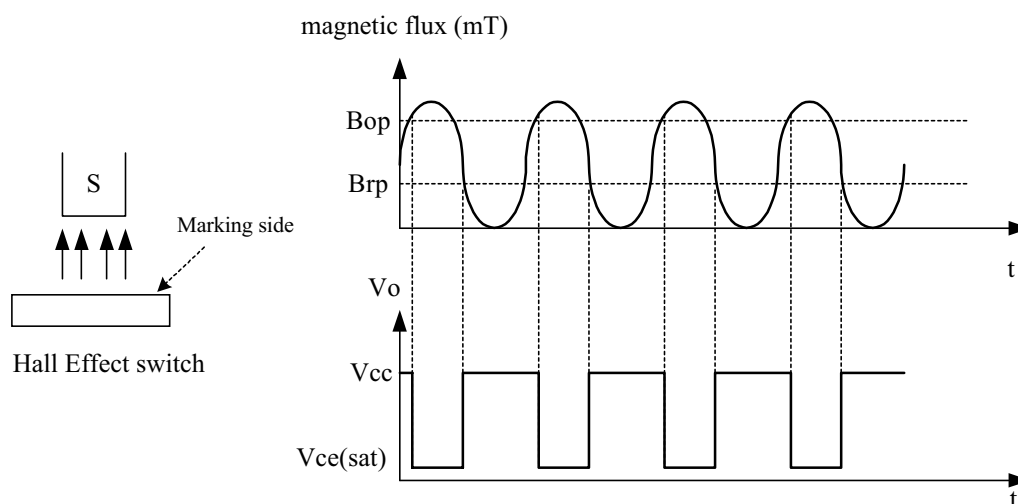

Fig.3  $V_o$  and magnetic flux variety

The major applications are for contactless switching and shown as follows:

- VCD/DVD loader, CD/DVD ROM: Detect if the tray is opened or closed
- Cover detector (open/close): Cellular phone cover detector, Refrigerator door detector, Microwave oven door sensor... etc
- Home safety: instead of reed relay to detect the situation of door/window.
- Due to contactless and without mechanical contact point, its reliability and life cycle are much longer than reed relay. In addition, its switching speed is much faster than mechanical devices.