

LED SPECS	UNITS	BLUE	GREEN
FORWARD CURRENT	mA	20	20
FORWARD VOLATGE	V	3.3 TYP - 4.0 MAX	2.1 TYP - 2.5 MAX
LUMINOUS INTENSITY	mcd	1000 TYP	300 TYP

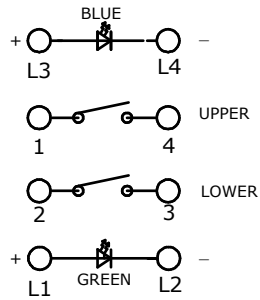

- NOTES:**
1. ALL DIMENSIONS IN MM
 2. GENERAL TOLERANCE: X.X=±0.4
X.XX=±0.25
 3. TERM. NOS. FOR REFERENCE ONLY.
 4. CONTACT RATING: 50mA @12VDC
 5. TRAVEL: 0.25 ±0.1mm
 6. CONTACT RESISTANCE: 100 Milli-Ohms Max.
 7. OPERATING FORCE: 160 ± 50gf
 - ▲ 8. CONTACT MATERIAL: SILVER
 9. MECHANICAL LIFE: 500,000 CYCLES
 10. OPERATING TEMP: -20°C TO 70°C
 - 11▲ DENOTES CRITICAL PARAMETER.
 - ▲ 12. PACKAGE: TRAY/ 84 PIECES PER
 13. 2002/95/EC (ROHS) COMPLIANT

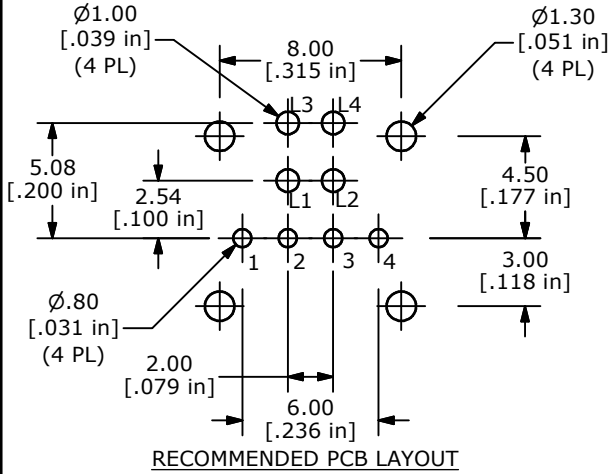
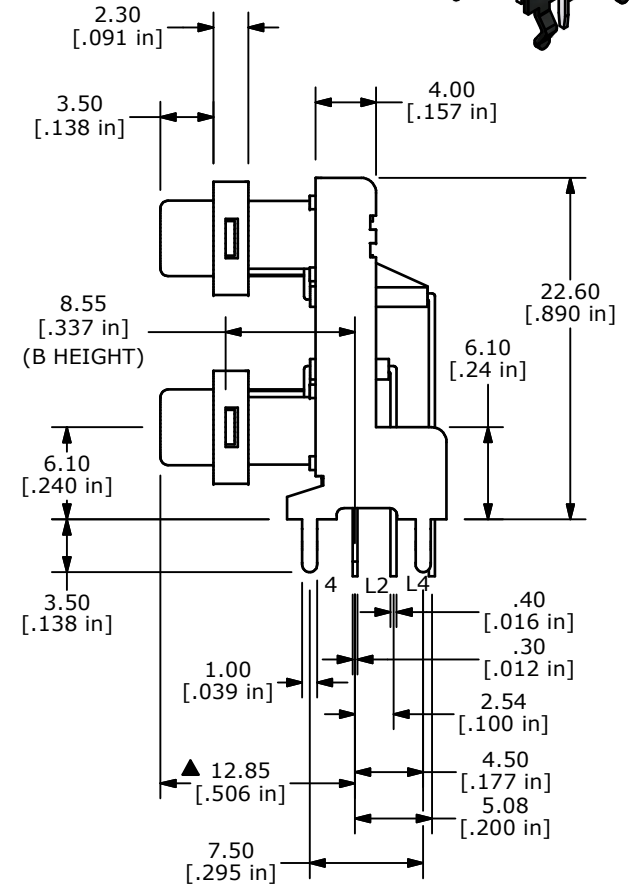
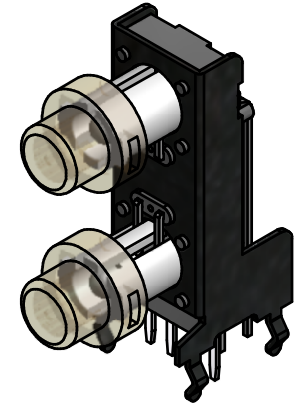
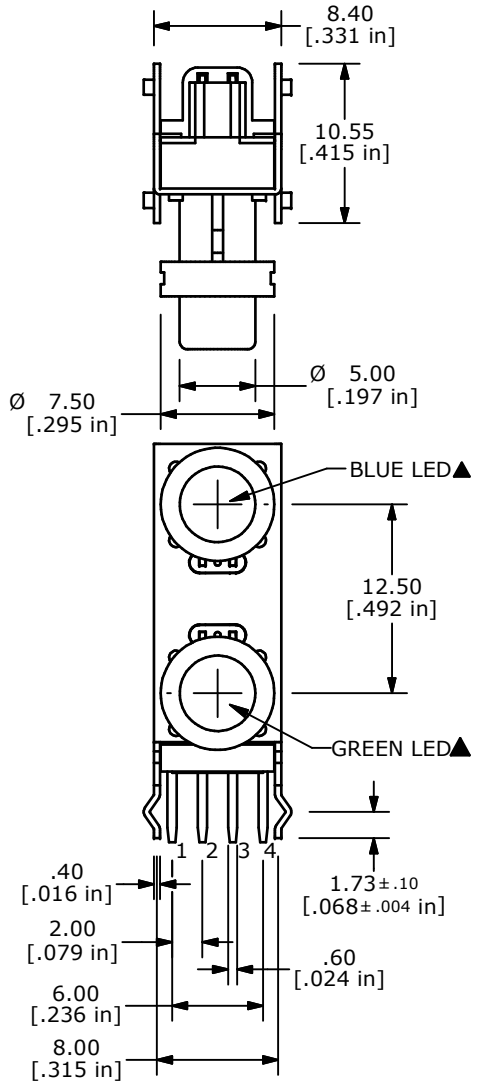

TITLE TL3253BBABGAF160Q

A	20873	RELEASE FOR PRODUCTION	11/8/12	EBP
REV	PCR NO	DESCRIPTION	DATE	BY
THE INFORMATION CONTAINED IN THIS DOCUMENT IS PROPRIETARY TO E-SWITCH AND IS NOT TO BE COPIED OR TRANSFERRED				

SCALE	DATE	DR	DWG	REV
	11/8/2012	EBP	B060007	A