

FSB50325A, FSB50325AT

Motion SPM® 5 FRFET® Series

Features

- 250 V $R_{DS(on)}$ = 1.7 Ω (Max) FRFET MOSFET 3-Phase Inverter Including HVICs
- Three Separate Open-Source Pins from Low Side MOSFETs for Three Leg Current Sensing
- HVIC for Gate Driving and Undervoltage Protection
- Active-High Interface, Can Work With 3.3 V / 5 V Logic
- Optimized for Low Electromagnetic Interference
- Isolation Voltage Rating of 1500 Vrms for 1 min.
- Temperature Sensing Built in HVIC
- Embedded Bootstrap Diode in the Package
- RoHS Compliant

Applications

- 3-Phase Inverter Driver for Small Power AC Motor Drives

General Description

FSB50325A and FSB50325AT are an Advanced Motion SPM5 Series Based on Fast-Recovery MOSFET(FRFET) Technology as a Compact Inverter Solution for Small Power Motor Drive Applications Such as Fans and Pumps. FSB50325A and FSB50325AT Contains Six FRFET MOSFETs, Three Half-Bridge Gate Drive HVICs with Temperature Sensing, and Three Bootstrap Diodes in a Compact Package Fully Isolated and Optimized for Thermal Performance. FSB50325A and FSB50325AT Features Low Electromagnetic Interference(EMI) Characteristics Through Optimizing Switching Speed and Reducing Parasitic Inductance. Since FSB50325A and FSB50325AT Employs MOSFETs as Power Switches, It Provides Much More Ruggedness and Larger Safe Operating Area(SOA) than IGBT-Based Power Modules. FSB50325A and FSB50325AT are the Right Solution for Compact and Reliable Inverter Designs Where the Assembly Space is Constrained.

Related Source

- [RD-FSB50450A : Reference Design for Motion SPM5 Series Ver.2](#)
- [AN-9082 : Motion SPM5 Series Thermal Performance by Contact Pressure](#)

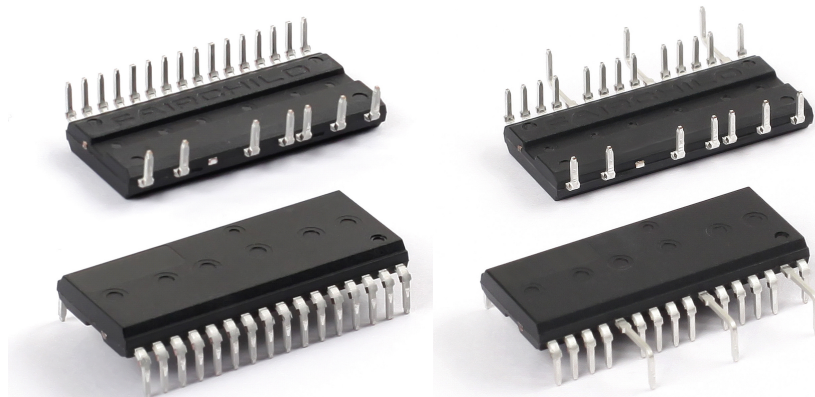

FSB50325A

FSB50325AT

Package Marking & Ordering Information

Device Marking	Device	Package	Reel Size	Packing Type	Quantity
FSB50325A	FSB50325A	SPM5P-023	-	RAIL	15
FSB50325AT	FSB50325AT	SPM5N-023	-	RAIL	15

Absolute Maximum Ratings

Inverter Part (Each MOSFET® Unless Otherwise Specified)

Symbol	Parameter	Conditions	Rating	Unit
V_{PN}	DC Link Input Voltage, Drain-Source Voltage of Each MOSFET		250	V
* I_{D25}	Each MOSFET Drain Current, Continuous	$T_C = 25^\circ\text{C}$	1.7	A
* I_{D80}	Each MOSFET Drain Current, Continuous	$T_C = 80^\circ\text{C}$	1.3	A
* I_{DP}	Each MOSFET Drain Current, Peak	$T_C = 25^\circ\text{C}$, $PW < 100 \mu\text{s}$	4.4	A
* I_{DRMS}	Each MOSFET Drain Current, Rms	$T_C = 80^\circ\text{C}$, $F_{PWM} < 20 \text{ KHz}$	0.9	A_{rms}
* P_D	Maximum Power Dissipation	$T_C = 25^\circ\text{C}$, For Each MOSFET	12.3	W

Control Part (Each HVIC Unless Otherwise Specified)

Symbol	Parameter	Conditions	Rating	Unit
V_{CC}	Control Supply Voltage	Applied Between V_{CC} and COM	20	V
V_{BS}	High-side Bias Voltage	Applied Between V_B and V_S	20	V
V_{IN}	Input Signal Voltage	Applied Between IN and COM	$-0.3 \sim V_{CC} + 0.3$	V

Bootstrap Diode Part (Each Bootstrap diode Unless Otherwise Specified)

Symbol	Parameter	Conditions	Rating	Unit
V_{RRMB}	Maximum Repetitive Reverse Voltage		250	V
* I_{FB}	Forward Current	$T_C = 25^\circ\text{C}$	0.5	A
* I_{FPB}	Forward Current (Peak)	$T_C = 25^\circ\text{C}$, Under 1ms Pulse Width	1.5	A

Thermal Resistance

Symbol	Parameter	Conditions	Rating	Unit
$R_{\theta JC}$	Junction to Case Thermal Resistance	Each MOSFET under Inverter Operating Condition (Note 1)	10.2	$^\circ\text{C/W}$

Total System

Symbol	Parameter	Conditions	Rating	Unit
T_J	Operating Junction Temperature		$-40 \sim 150$	$^\circ\text{C}$
T_{STG}	Storage Temperature		$-40 \sim 125$	$^\circ\text{C}$
V_{ISO}	Isolation Voltage	60 Hz, Sinusoidal, 1 minute, Connection Pins to Heatsink	1500	V_{rms}

Note:

1. For the Measurement Point of Case Temperature T_C , Please refer to Figure 4.
2. Marking "*" is Calculation Value or Design Factor.

Pin descriptions

Pin Number	Pin Name	Pin Description
1	COM	IC Common Supply Ground
2	$V_{B(U)}$	Bias Voltage for U Phase High Side MOSFET® Driving
3	$V_{CC(U)}$	Bias Voltage for U Phase IC and Low Side MOSFET Driving
4	$IN_{(UH)}$	Signal Input for U Phase High-Side
5	$IN_{(UL)}$	Signal Input for U Phase Low-Side
6	N.C	N.C
7	$V_{B(V)}$	Bias Voltage for V Phase High Side MOSFET Driving
8	$V_{CC(V)}$	Bias Voltage for V Phase IC and Low Side MOSFET Driving
9	$IN_{(VH)}$	Signal Input for V Phase High-Side
10	$IN_{(VL)}$	Signal Input for V Phase Low-Side
11	V_{TS}	Output for HVIC Temperature Sensing
12	$V_{B(W)}$	Bias Voltage for W Phase High Side MOSFET Driving
13	$V_{CC(W)}$	Bias Voltage for W Phase IC and Low Side MOSFET Driving
14	$IN_{(WH)}$	Signal Input for W Phase High-Side
15	$IN_{(WL)}$	Signal Input for W Phase Low-Side
16	N.C	N.C
17	P	Positive DC-Link Input
18	U, $V_{S(U)}$	Output for U Phase & Bias Voltage Ground for High Side MOSFET Driving
19	N_U	Negative DC-Link Input for U Phase
20	N_V	Negative DC-Link Input for V Phase
21	V, $V_{S(V)}$	Output for V Phase & Bias Voltage Ground for High Side MOSFET Driving
22	N_W	Negative DC-Link Input for W Phase
23	W, $V_{S(W)}$	Output for W Phase & Bias Voltage Ground for High Side MOSFET Driving

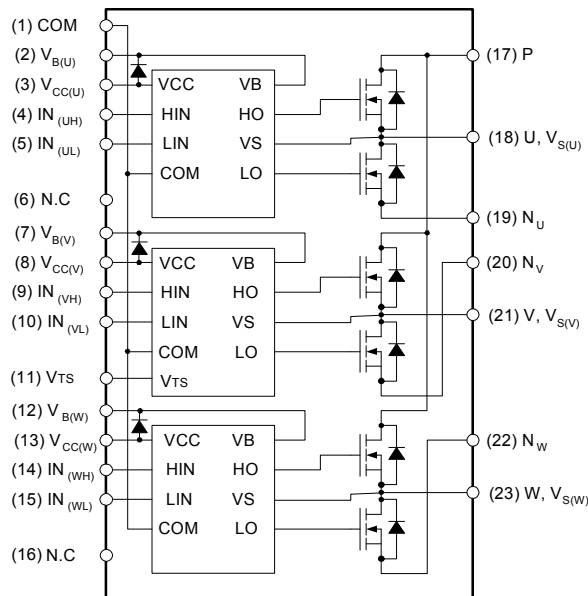

Note:

Source Terminal of Each Low-Side MOSFET is Not Connected to Supply Ground or Bias Voltage Ground Inside Motion SPM®.
External Connections Should be Made as Indicated in Figure 3

Figure 1. Pin Configuration and Internal Block Diagram (Bottom View)

Electrical Characteristics (T_J = 25°C, V_{CC}=V_{BS} = 15 V Unless Otherwise Specified)

Inverter Part (Each MOSFET® Unless Otherwise Specified)

Symbol	Parameter	Conditions	Min	Typ	Max	Unit
BV _{DSS}	Drain-Source Breakdown Voltage	V _{IN} = 0V, I _D = 1 mA (Note 1)	250	-	-	V
I _{DSS}	Zero Gate Voltage Drain Current	V _{IN} = 0V, V _{DS} = 250 V	-	-	1	mA
R _{DS(on)}	Static Drain-Source On-Resistance	V _{CC} = V _{BS} = 15 V, V _{IN} = 5 V, I _D = 1.0 A	-	1.1	1.7	Ω
V _{SD}	Drain-Source Diode Forward Voltage	V _{CC} = V _{BS} = 15V, V _{IN} = 0V, I _D = - 1.0 A	-	-	1.2	V
t _{ON}	Switching Times	V _{PN} = 150 V, V _{CC} = V _{BS} = 15 V, I _D = 1.0 A V _{IN} = 0 V ↔ 5 V, Inductive Load L= 3 mH High- and Low-Side MOSFET Switching (Note 2)	-	810	-	ns
t _{OFF}			-	600	-	ns
t _{rr}			-	140	-	ns
E _{ON}			-	40	-	μJ
E _{OFF}			-	10	-	μJ
RBSOA	Reverse-Bias Safe Operating Area	V _{PN} = 200 V, V _{CC} = V _{BS} = 15 V, I _D = I _{DP} , V _{DS} =BV _{DSS} , T _J = 150°C High- and Low-Side MOSFET Switching (Note 3)	Full Square			

Control Part (Each HVIC Unless Otherwise Specified)

Symbol	Parameter	Conditions	Min	Typ	Max	Unit
I _{QCC}	Quiescent V _{CC} Current	V _{CC} =15 V, V _{IN} =0V Applied Between V _{CC} and COM	-	-	200	μA
I _{QBS}	Quiescent V _{BS} Current	V _{BS} =15 V, V _{IN} =0V Applied Between V _{B(U)} -U, V _{B(V)} -V, V _{B(W)} -W	-	-	100	μA
UV _{CCD}	Low-Side Undervoltage Protection (Figure 8)	V _{CC} Undervoltage Protection Detection Level	7.4	8.0	9.4	V
UV _{CCR}		V _{CC} Undervoltage Protection Reset Level	8.0	8.9	9.8	V
UV _{BSD}	High-Side Undervoltage Protection (Figure 9)	V _{BS} Undervoltage Protection Detection Level	7.4	8.0	9.4	V
UV _{BSR}		V _{BS} Undervoltage Protection Reset Level	8.0	8.9	9.8	V
V _{TS}	HVIC Temperature Sensing Voltage Output	V _{CC} = 15 V, T _{HVIC} = 25°C (Note 4)	600	790	980	mV
V _{IH}	ON Threshold Voltage	Logic High Level	-	-	2.9	V
V _{IL}	OFF Threshold Voltage	Logic Low Level	0.8	-	-	V

Bootstrap Diode Part (Each Bootstrap diode Unless Otherwise Specified)

Symbol	Parameter	Conditions	Min	Typ	Max	Unit
V _{FB}	Forward Voltage	I _F = 0.1 A, T _C = 25°C (Note 5)	-	2.5	-	V
t _{trB}	Reverse Recovery Time	I _F = 0.1 A, T _C = 25°C	-	80	-	ns

Note:

- BV_{DSS} is the Absolute Maximum Voltage Rating Between Drain and Source Terminal of Each MOSFET Inside Motion SPM®. V_{PN} Should be Sufficiently Less Than This Value Considering the Effect of the Stray Inductance so that V_{DS} Should Not Exceed BV_{DSS} in Any Case.
- t_{ON} and t_{OFF} Include the Propagation Delay Time of the Internal Drive IC. Listed Values are Measured at the Laboratory Test Condition, and They Can be Different According to the Field Applications Due to the Effect of Different Printed Circuit Boards and Wirings. Please see Figure 6 for the Switching Time Definition with the Switching Test Circuit of Figure 7.
- The peak current and voltage of each MOSFET during the switching operation should be included in the safe operating area (SOA). Please see Figure 7 for the RBSOA test circuit that is same as the switching test circuit.
- V_{TS} is only for sensing temperature of module and cannot shutdown MOSFETs automatically.
- Built in bootstrap diode includes around 15Ω resistance characteristic. Please refer to Figure 2.

Recommended Operating Condition

Symbol	Parameter	Conditions	Value			Unit
			Min.	Typ.	Max.	
V_{PN}	Supply Voltage	Applied Between P and N	-	150	200	V
V_{CC}	Control Supply Voltage	Applied Between V_{CC} and COM	13.5	15	16.5	V
V_{BS}	High-Side Bias Voltage	Applied Between V_B and V_S	13.5	15	16.5	V
$V_{IN(ON)}$	Input ON Threshold Voltage	Applied Between IN and COM	3.0	-	V_{CC}	V
$V_{IN(OFF)}$	Input OFF Threshold Voltage		0	-	0.6	V
t_{dead}	Blanking Time for Preventing Arm-Short	$V_{CC}=V_{BS}= 13.5 \sim 16.5$ V, $T_J \leq 150^\circ\text{C}$	1.0	-	-	μs
f_{PWM}	PWM Switching Frequency	$T_J \leq 150^\circ\text{C}$	-	15	-	kHz

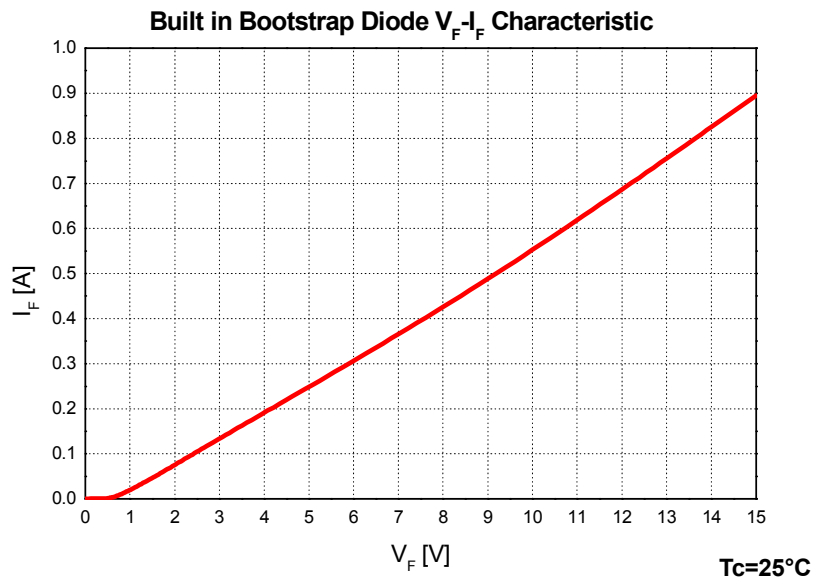
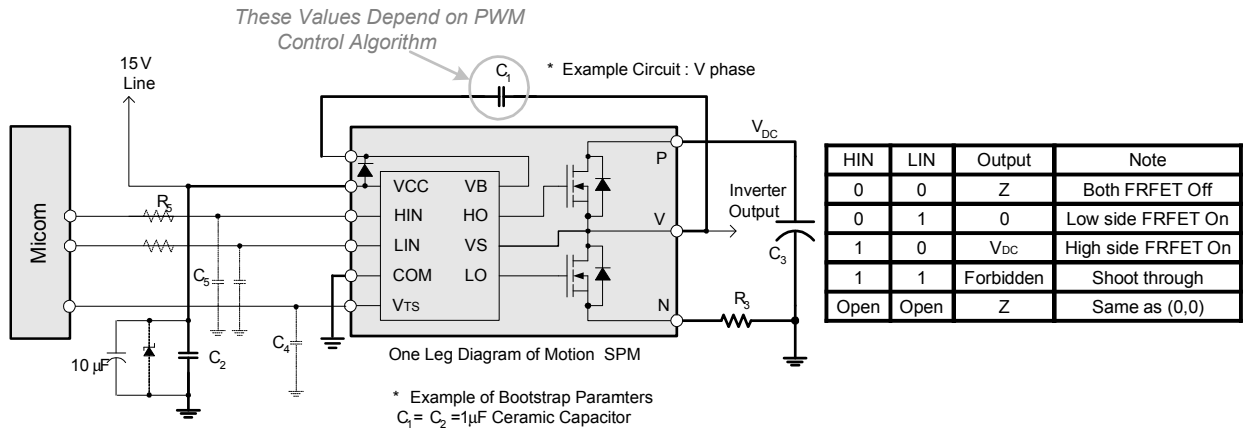

Figure 2. Built in Bootstrap Diode Characteristics (Typ.)



Note:

- Parameters for Bootstrap Circuit Elements are Dependent on PWM Algorithm. For 15 kHz of Switching Frequency, Typical Example of Parameters is Shown Above.
- RC coupling (R₅ and C₅) and C₄ at Each Input of Motion SPM® and Microm (Indicated as Dotted Lines) May be Used to Prevent Improper Signal Due to Surge Noise.
- Bold lines should be short and thick in PCB pattern to have small stray inductance of circuit, which results in the reduction of surge voltage. Bypass capacitors such as C₁, C₂ and C₃ Should Have Good High-Frequency characteristics to Absorb High-Frequency Ripple Current.

Figure 3. Recommended MCU Interface and Bootstrap Circuit with Parameters

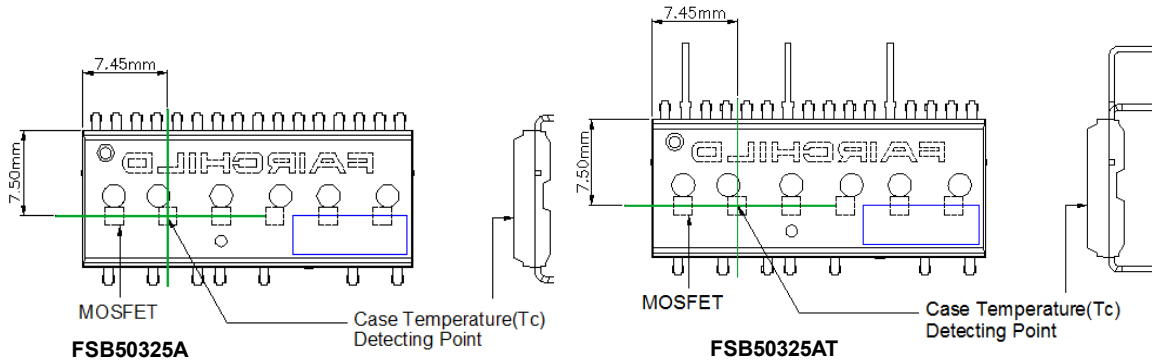

Note:

Attach the thermocouple on top of the heatsink-side of Motion SPM (between Motion SPM and heatsink if applied) to get the correct temperature measurement.

Figure 4. Case Temperature Measurement

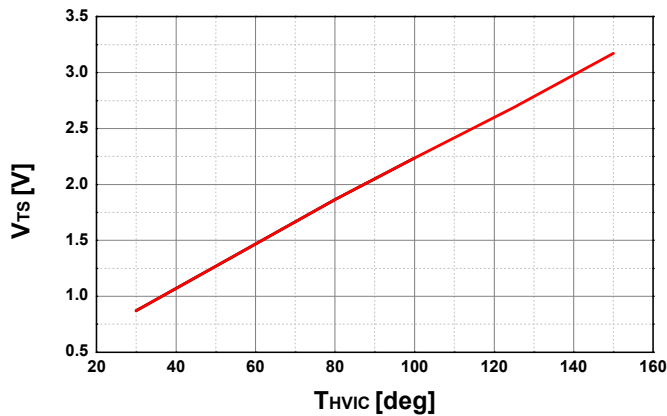
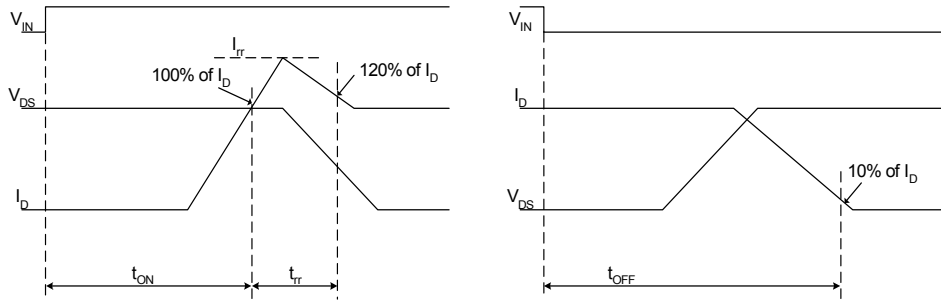

Figure 5. Temperature Profile of Vts (Typ.)



(a) Turn-on (b) Turn-off
Figure 6. Switching Time Definitions

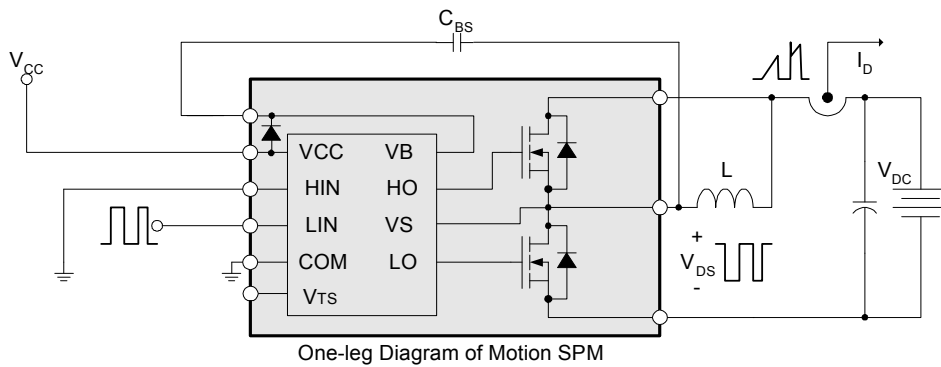

Figure 7. Switching and RBSOA (Single-pulse) Test Circuit (Low-side)

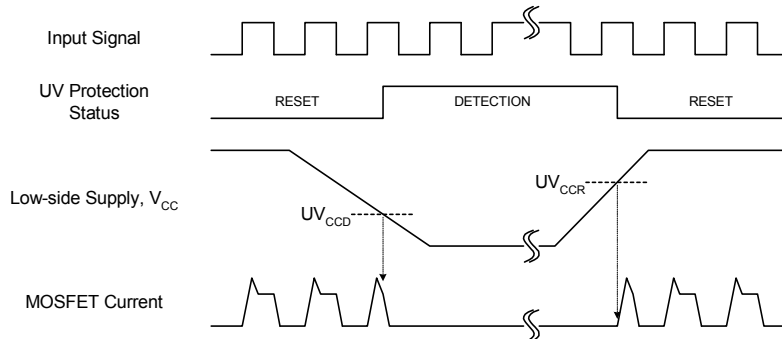

Figure 8. Undervoltage Protection (Low-side)

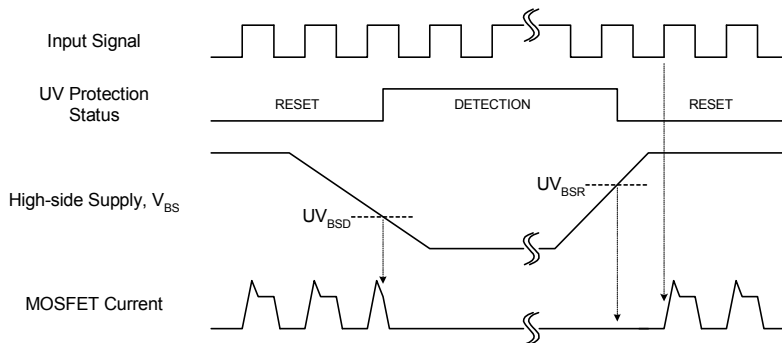
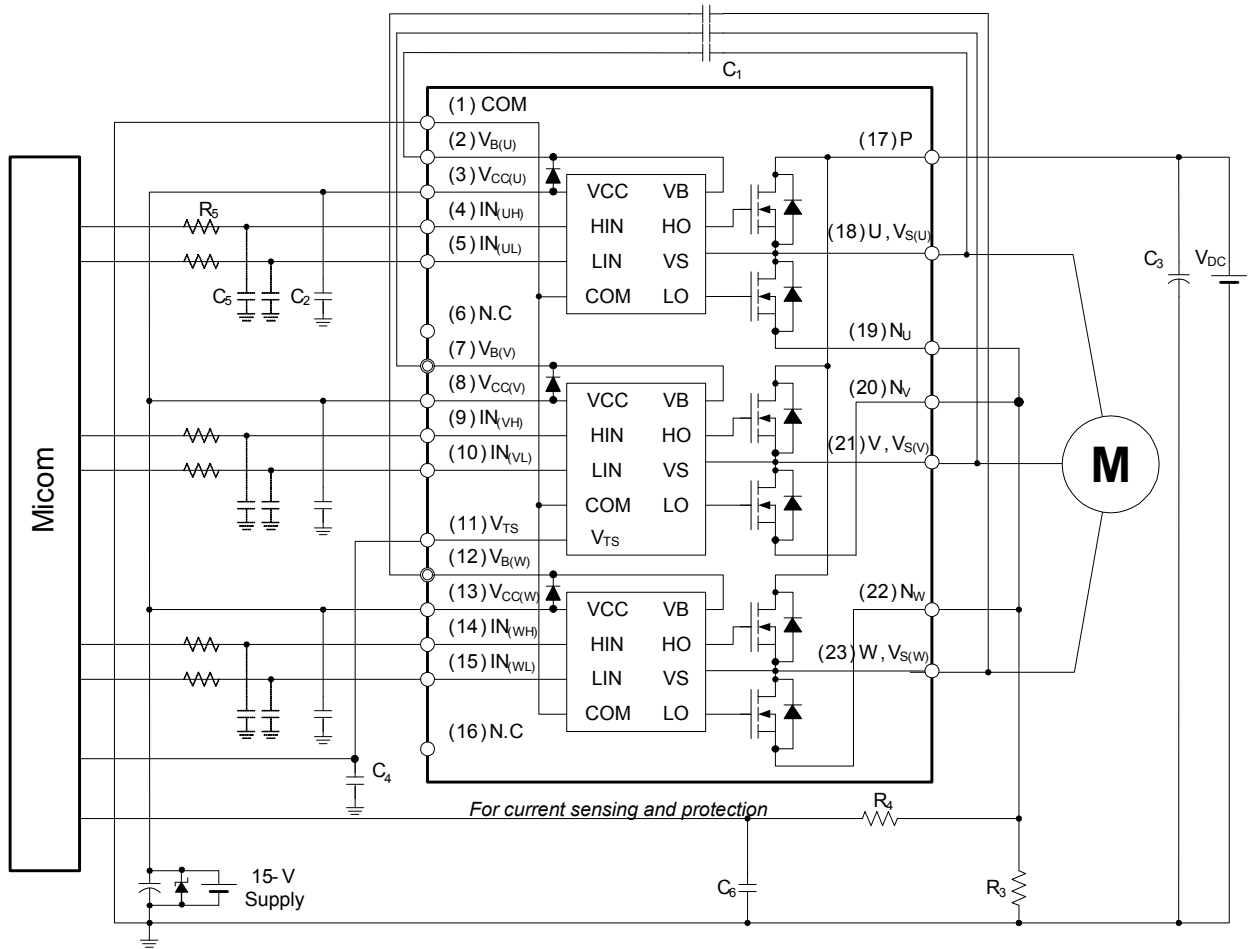

Figure 9. Undervoltage Protection (High-side)



Note:

1. About Pin Position, Refer to Figure 1.
2. RC Coupling (R_5 and C_5 , R_4 and C_6) and C_4 at Each Input of Motion SPM® and Microm are Useful to Prevent Improper Input Signal Caused by Surge Noise.
3. The voltage Drop Across R_3 Affects the Low Side Switching Performance and the Bootstrap Characteristics Since it is Placed Between COM and the Source Terminal of the Low Side MOSFET. For this Reason, the Voltage Drop Across R_3 Should Be Less Than 1 V in the Steady-State.
4. Ground Wires and Output Terminals, Should Be Thick and Short in Order to Avoid Surge Voltage and Malfunction of HVIC.
5. All the Filter Capacitors Should Be Connected Close to Motion SPM, and They Should Have Good Characteristics for Rejecting High-Frequency Ripple Current.

Figure 10. Example of Application Circuit

Detailed Package Outline Drawings (FSB50325A)

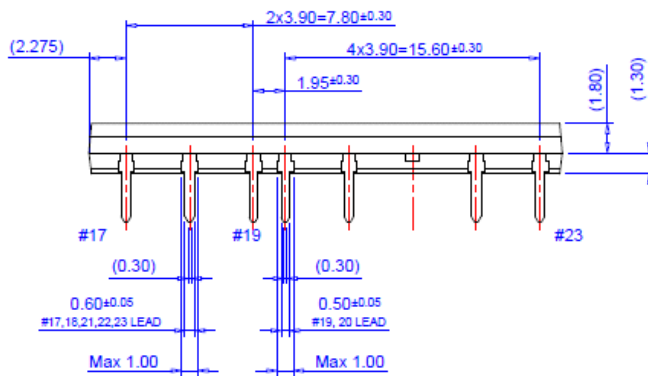
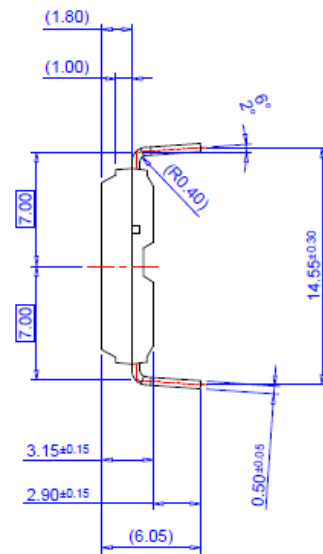
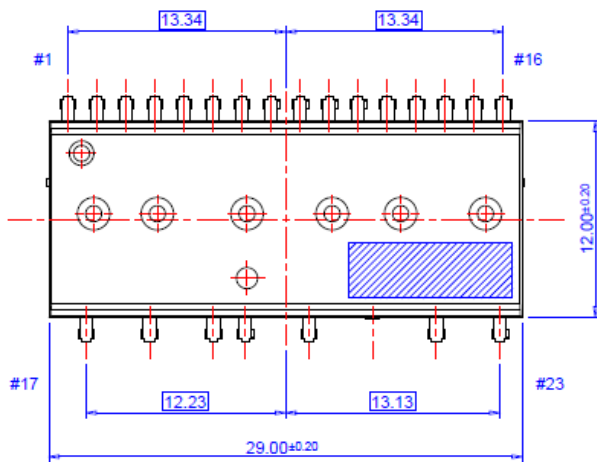
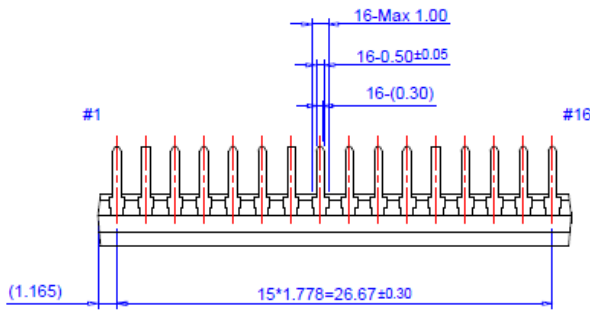

Dimension unit : [mm]

Detailed Package Outline Drawings (FSB50325AT)

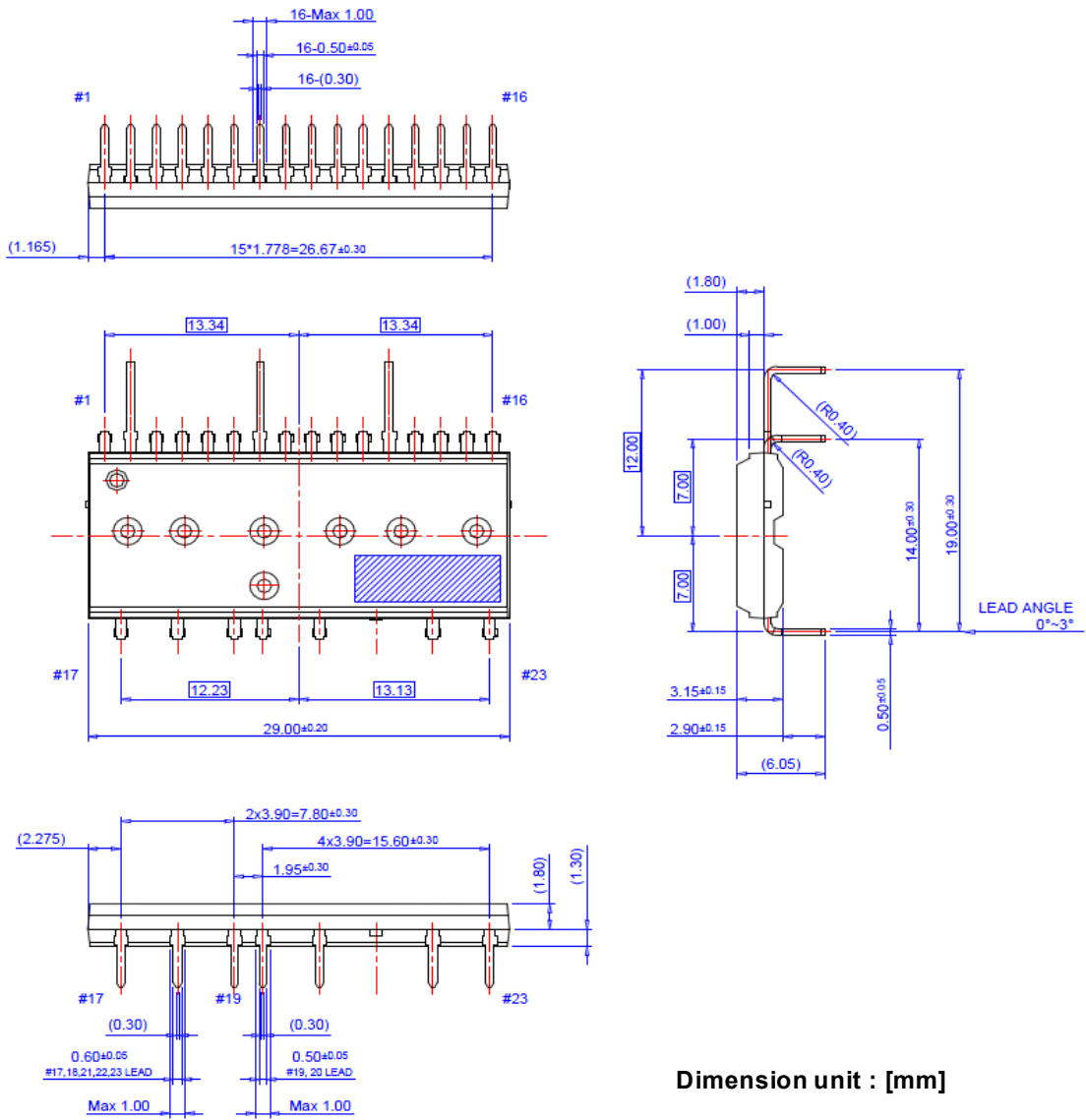



Dimension unit : [mm]





TRADEMARKS

The following includes registered and unregistered trademarks and service marks, owned by Fairchild Semiconductor and/or its global subsidiaries, and is not intended to be an exhaustive list of all such trademarks.

Build it Now™
 CorePLUS™
 CorePOWER™
 CROSSVOLT™
 CTL™
 Current Transfer Logic™
 EcoSPARK®
 EfficientMax™
 EZSWITCH™ *

 Fairchild®
 Fairchild Semiconductor®
 FACT Quiet Series™
 FACT®
 FAST®
 FastvCore™
 FlashWriter® *
 FPS™
 F-PFS™

FRFET®
 Global Power Resource™
 Green FPS™
 Green FPS™ e-Series™
 GTO™
 IntelliMAX™
 ISOPLANAR™
 MegaBuck™
 MICROCOPLER™
 MicroFET™
 MicroPak™
 MillerDrive™
 MotionMax™
 Motion-SPM™
 OPTOLOGIC®
 OPTOPLANAR®

 PDP SPM™
 Power-SPM™
 PowerTrench®
 PowerXS™

Programmable Active Droop™
 QFET®
 QS™
 Quiet Series™
 RapidConfigure™

 Saving our world, 1mW /W /kW at a time™
 SmartMax™
 SMART START™
 SPM®
 STEALTH™
 SuperFET™
 SuperSOT™_3
 SuperSOT™_6
 SuperSOT™_8
 SupreMOS™
 SyncFET™

 The Power Franchise®

the power franchise
 TinyBoost™
 TinyBuck™
 TinyLogic®
 TINYOPTO™
 TinyPower™
 TinyPWM™
 TinyWire™
 TriFault Detect™
 μSerDes™

 UHC®
 Ultra FRFET™
 UniFET™
 VCX™
 VisualMax™
 XS™

* EZSWITCH™ and FlashWriter® are trademarks of System General Corporation, used under license by Fairchild Semiconductor.

DISCLAIMER

FAIRCHILD SEMICONDUCTOR RESERVES THE RIGHT TO MAKE CHANGES WITHOUT FURTHER NOTICE TO ANY PRODUCTS HEREIN TO IMPROVE RELIABILITY, FUNCTION, OR DESIGN. FAIRCHILD DOES NOT ASSUME ANY LIABILITY ARISING OUT OF THE APPLICATION OR USE OF ANY PRODUCT OR CIRCUIT DESCRIBED HEREIN; NEITHER DOES IT CONVEY ANY LICENSE UNDER ITS PATENT RIGHTS, NOR THE RIGHTS OF OTHERS. THESE SPECIFICATIONS DO NOT EXPAND THE TERMS OF FAIRCHILD'S WORLDWIDE TERMS AND CONDITIONS, SPECIFICALLY THE WARRANTY THEREIN, WHICH COVERS THESE PRODUCTS.

LIFE SUPPORT POLICY

FAIRCHILD'S PRODUCTS ARE NOT AUTHORIZED FOR USE AS CRITICAL COMPONENTS IN LIFE SUPPORT DEVICES OR SYSTEMS WITHOUT THE EXPRESS WRITTEN APPROVAL OF FAIRCHILD SEMICONDUCTOR CORPORATION.

As used herein:

- Life support devices or systems are devices or systems which, (a) are intended for surgical implant into the body or (b) support or sustain life, and (c) whose failure to perform when properly used in accordance with instructions for use provided in the labeling, can be reasonably expected to result in a significant injury of the user.
- A critical component in any component of a life support, device, or system whose failure to perform can be reasonably expected to cause the failure of the life support device or system, or to affect its safety or effectiveness.

ANTI-COUNTERFEITING POLICY

Fairchild Semiconductor Corporation's Anti-Counterfeiting Policy. Fairchild's Anti-Counterfeiting Policy is also stated on our external website, www.Fairchildsemi.com, under Sales Support.

Counterfeiting of semiconductor parts is a growing problem in the industry. All manufactures of semiconductor products are experiencing counterfeiting of their parts. Customers who inadvertently purchase counterfeit parts experience many problems such as loss of brand reputation, substandard performance, failed application, and increased cost of production and manufacturing delays. Fairchild is taking strong measures to protect ourselves and our customers from the proliferation of counterfeit parts. Fairchild strongly encourages customers to purchase Fairchild parts either directly from Fairchild or from Authorized Fairchild Distributors who are listed by country on our web page cited above. Products customers buy either from fairchild directly or from Authorized Fairchild Distributors are genuine parts, have full traceability, meet Fairchild's quality standards for handling and storage and provide access to Fairchild's full range of up-to-date technical and product information. Fairchild and our Authorized Distributors will stand behind all warranties and will appropriately address and warranty issues that may arise. Fairchild will not provide any warranty coverage or other assistance for parts bought from Unauthorized Sources. Fairchild is committed to combat this global problem and encourage our customers to do their part in stopping this practice by buying direct or from authorized distributors.

PRODUCT STATUS DEFINITIONS

Definition of Terms

Datasheet Identification	Product Status	Definition
Advance Information	Formative / In Design	Datasheet contains the design specifications for product development. Specifications may change in any manner without notice.
Preliminary	First Production	Datasheet contains preliminary data; supplementary data will be published at a later date. Fairchild Semiconductor reserves the right to make changes at any time without notice to improve design.
No Identification Needed	Full Production	Datasheet contains final specifications. Fairchild Semiconductor reserves the right to make changes at any time without notice to improve the design.
Obsolete	Not In Production	Datasheet contains specifications on a product that is discontinued by Fairchild Semiconductor. The datasheet is for reference information only.

Rev. I38