

### Features

- Supports ITU Specifications <sup>1</sup>
- Supports Incoming and Outgoing Calls
- Auto-bauding and Auto-parity
- Hayes Compatible 'AT' Command Set
- V.120 Rate Adaption
- PPP Async to Sync Conversion
- Supports CTR3 Approval
- Voice and User Data via B Channels
- *Full API Available*

### Applications

- Feature Phones with Data Interfaces
- Pay-Phones
- PABX Telephones + Data
- Data Terminal Adapters
- EPOS Terminals
- Remote Metering and Alarm Systems
- H.320 Video Phones
- *Reference Designs Available*

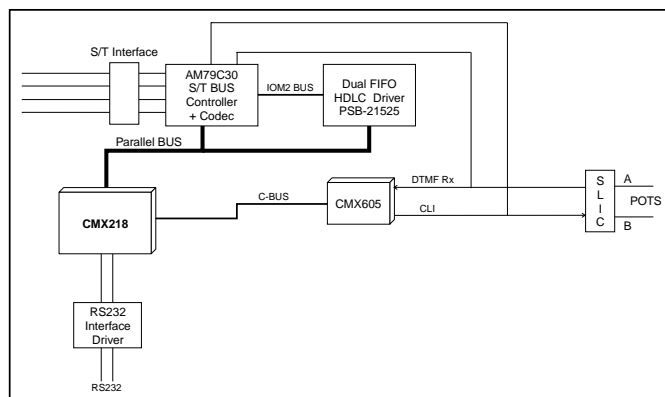

The CMX218 is an ISDN data and telephony protocol engine which implements the lower level ISDN interface and communicates with the CMX605 and other standard devices to form a fully integrated ISDN chipset for both voice and data communications. The CMX218 puts all the main data processing elements in a single device. No ISDN software has to be written and simple 'Plug and Play' design results. This reduces development time and provides a highly cost-effective hardware solution. By using proven circuit designs, the designer can move quickly from initial concept through design in to manufacture.

The CMX218 supports one voice port over the ISDN Line, which can be used to provide ISDN telephony services or a POTS line interface, and a single data channel, capable of operation at 115,200 bps. The CMX218 features a full set of 'Hayes' compatible AT command codes on its asynchronous data interface, in addition to providing keypad-configurable voice telephony services. The CMX218's feature set and architecture allow most analog systems to be converted to an ISDN equivalent with enhanced features.

The CMX218 is designed to work with the AMD 79C30 S/T bus interface, the Siemens PSB-21525 HDLC formatter and the MX-COM CMX605 POTS interface circuit, and also comes complete with embedded applications software. To support the CMX218, MX-COM can also provide licensed reference designs on user request. A flexible Applications Program Interface (API) allows users to customize the features and operation of their own design. The CMX218 is available in an 80-pin QFP (CMX218S1) package.

<sup>1</sup> The CMX218 is a data processor integrated circuit that supports the protocol layers 1, 2 and 3 of the ISDN protocol stack in accordance with the specifications of CCITT (now ITU). These specifications, which are widely used around the world, might not be supported within the U.S.

# CONTENTS

Section	Page
<b>1. Block Diagram</b> .....	<b>4</b>
<b>2. Signal List</b> .....	<b>5</b>
<b>3. External Components</b> .....	<b>7</b>
<b>4. General Description</b> .....	<b>8</b>
4.1 Glossary .....	9
4.2 Initialization.....	10
4.3 ISDN Interface .....	10
4.3.1 Activation.....	10
4.3.2 De-activation or Line Disconnection.....	10
4.3.3 Line Failure Detection .....	10
4.3.4 Incoming Calls.....	10
4.3.5 Multiple Subscriber Numbering .....	11
4.3.6 Channel Mapping .....	11
4.4 POTS Configuration .....	12
4.4.1 Configuration and Control via DTMF Keypad.....	12
4.5 POTS Operation .....	13
4.5.1 Keypad Operation .....	13
4.5.2 Incoming POTS Calls .....	13
4.5.3 Outgoing POTS Calls .....	14
4.5.4 Connected Calls .....	14
4.5.5 Call Clearing.....	14
4.6 Data Configuration.....	15
4.6.1 Hayes Command Set .....	15
4.6.2 Hayes Register Set .....	19
4.7 Data Operation .....	20
4.7.1 Incoming B-Channel Data Calls .....	20
4.7.2 Outgoing B-Channel Data Calls .....	21
4.7.3 Connected Calls .....	21
4.7.4 Call Clearing.....	21
4.8 Application Programmer's Interface.....	21
4.9 Hardware Description .....	22
4.9.1 LED Status Indicators (LED1 to LED9, and ILF1).....	22
<b>5. Application Notes</b> .....	<b>23</b>
5.1 General.....	23
5.2 Approvals.....	23

<b>6. Performance Specification.....</b>	<b>24</b>
6.1 Electrical Performance .....	24
6.1.1 Absolute Maximum Ratings.....	24
6.1.2 Operating Limits .....	24
6.1.3 Operating Characteristics.....	25
6.2 Packaging.....	30

MX-COM, Inc. reserves the right to change specifications at any time and without notice.
--

# 1. Block Diagram

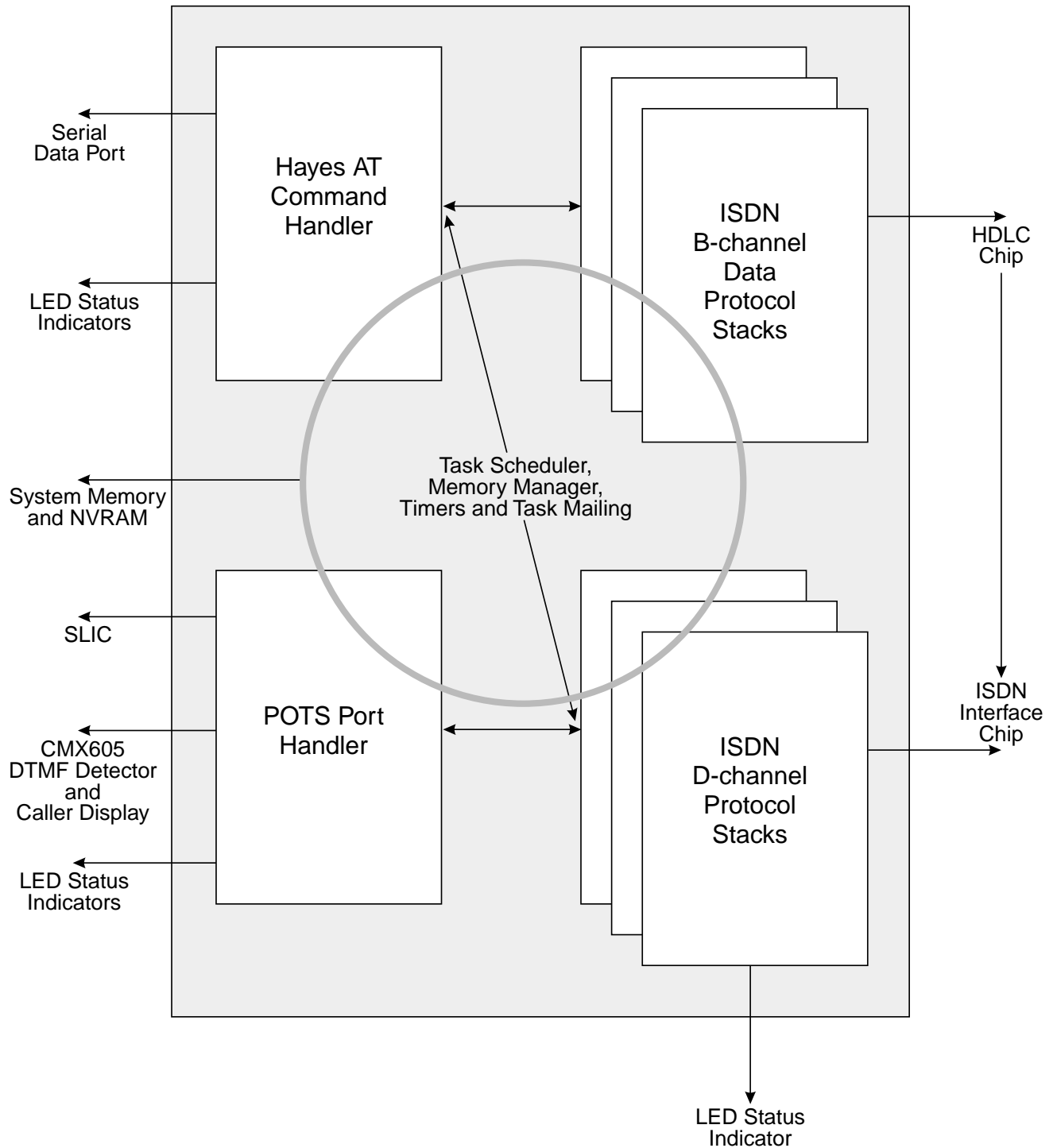

Figure 1: Block Diagram

## 2. Signal List

S1 Package Pin No.	Signal		Description
	Name	Type	
1	SCL	output	EEPROM - Serial Clock
2	SDA	bi-directional	EEPROM - Serial Data
3	ISDNRST	output	ISDN S-interface Chip Reset
4	RI1	output	RS232 Port1 Ring Indicator (high when inactive)
5	DCD1	output	RS232 Port1 Data Carrier Detect (high when inactive)
6	CTS1	output	RS232 Port1 Clear To Send (high when inactive)
7	$\overline{\text{RST}}$	input	CMX218 Chip Reset (active low)
8	DV <sub>DD1</sub>	Power	The digital positive supply rail. Levels and voltages are dependent upon this supply. This pin should be decoupled to DV <sub>SS</sub> by a capacitor
9	$\overline{\text{XTAL}}$	output	The output of the on-chip Xtal oscillator inverter
10	XTAL	input	The input to the oscillator inverter from the Xtal circuit
11	DV <sub>SS1</sub>	power	The digital negative supply rail (ground)
12	LED1	output	POTS Port Off-Hook Indicator (HK1)
13	LED2	output	RS232 Port 1 Auto-Answer Indicator (AA)
14	LED3	output	RS232 Port 1 Data Carrier Detect Indicator (DCD)
15	LED4	output	RS232 Port 1 Ready To Send Indicator (RTS)
16	LED5	output	RS232 Port 1 Receive Data Indicator (RXD)
17	LED6	output	RS232 Port 1 Transmit Data Indicator (TXD)
18	LED7	output	RS232 Port 1 Data Terminal Ready Indicator (DTR)
19	LED8	output	ISDN Line Activated Indicator (AR)
20	$\overline{\text{ST}}$	output	Watchdog Timer Stimulus
21	LED9	output	POTS Port Call Connected Indicator (CN1)
22	$\overline{\text{WR}}$	output	Memory Write Access Strobe
23	$\overline{\text{RD}}$	output	Memory Read Access Strobe
24	A19	output	Memory and Peripheral Address Bus
25	A18	output	Memory and Peripheral Address Bus
26	A17	output	Memory and Peripheral Address Bus
27	A16	output	Memory and Peripheral Address Bus
28	A15	output	Memory and Peripheral Address Bus
29	A14	output	Memory and Peripheral Address Bus
30	A13	output	Memory and Peripheral Address Bus
31	A12	output	Memory and Peripheral Address Bus
32	A11	output	Memory and Peripheral Address Bus
33	A10	output	Memory and Peripheral Address Bus
34	A9	output	Memory and Peripheral Address Bus
35	A8	output	Memory and Peripheral Address Bus
36	A/D7	bi-directional	Memory and Peripheral Address and Data Bus
37	A/D6	bi-directional	Memory and Peripheral Address and Data Bus
38	A/D5	bi-directional	Memory and Peripheral Address and Data Bus

S1 Package	Signal		Description	
	Pin No.	Name		Type
	39	A/D4	bi-directional	Memory and Peripheral Address and Data Bus
	40	A/D3	bi-directional	Memory and Peripheral Address and Data Bus
	41	A/D2	bi-directional	Memory and Peripheral Address and Data Bus
	42	A/D1	bi-directional	Memory and Peripheral Address and Data Bus
	43	A/D0	bi-directional	Memory and Peripheral Address and Data Bus
	44	ASTB	output	Address/Data Bus Strobe (data bus selected if low)
	45	DV <sub>SS0</sub>	power	The digital negative supply rail (ground)
	46	~	input	For manufacturer's use only. Connect to DV <sub>SS</sub> directly
	47	PSBRES	output	HDLC Chip Reset
	48	N/C	output	Do not make any connection to this pin
	49	N/C	output	Do not make any connection to this pin
	50	API-RXD	input	API/RS232 Port 2 Rx Data (inactive = high)
	51	API-TXD	output	API/RS232 Port 2 Tx Data (high when inactive)
	52	N/C	output	Do not make any connection to this pin
	53	N/C	output	Do not make any connection to this pin
	54	ILFI	output	ISDN Line Failure Indicator
	55	DV <sub>DD0</sub>	power	The digital positive supply rail. Levels and voltages are dependent upon this supply. This pin should be decoupled to DV <sub>SS</sub> by a capacitor
	56	RING1	output	POTS Port Ringing Generator (low when not ringing)
	57	$\overline{\text{RING}}1$	output	POTS Port Ringing Generator (high when not ringing)
	58	CLIP1	output	POTS Port Line Voltage Adjustment (low when sending FSK to a Caller Display unit. If low, it makes the SLIC present a high impedance to the POTS line)
	59	ILINE1	input	POTS Port Hook Switch Status Detector (on-hook = low)
	60	~	input	For manufacturers' use only. Connect to DV <sub>SS</sub> directly
	61	REPLY	input	CMX605 C-BUS Interface - Reply Data
	62	CMD-DATA	output	CMX605 C-BUS Interface - Command Data
	63	SER-CLK	output	CMX605 C-BUS Interface - Serial Clock
	64	AV <sub>DD</sub>	power	The positive analog supply rail. Levels and voltages are dependent upon this supply. This pin should be decoupled to AV <sub>SS</sub> by a capacitor
	65	AV <sub>REF1</sub>	power	A/D Reference Voltage. Connect to AV <sub>DD</sub> directly
	66	AV <sub>SS</sub>	power	The negative analog supply rail (ground)
	67	$\overline{\text{CS}}1$	output	CMX605 C-BUS Interface (chip select for POTS Port)
	68	N/C	output	Do not make any connection to this pin
	69	AV <sub>REF2</sub>	power	D/A Reference Voltage. Connect to AV <sub>DD</sub> directly
	70	AV <sub>REF3</sub>	power	D/A Reference Voltage. Connect to AV <sub>SS</sub> directly
	71	NMI	input	For manufacturer's use only. Connect to DV <sub>SS</sub> directly
	72	API-INT	input	API Interrupt (inactive = high)
	73	$\overline{\text{IRQ}}$	input	CMX605 C-BUS Interface - Interrupt (inactive = high)



## 4. General Description

The CMX218 is a single-chip data processor that has been mask programmed with firmware to implement an ISDN protocol stack. This enables the CMX218 to interface an analog (POTS) port and a digital (RS232) port to an ISDN S-bus network connection. Key variables are stored in an external EEPROM and the user can provide additional features by adding external ROM and RAM. Access to the firmware Application Programmer's Interface (API) facilitates the seamless integration of the user's additional features with the pre-programmed ISDN to POTS and RS232 interfaces.

The CMX218 is intended for use as part of an ISDN chipset and all descriptions in this data sheet refer to this implementation, which is shown diagrammatically in Figure 3. The use of alternative chipsets is not supported.

The firmware supports connection to an ISDN S-bus network interface via the Siemens PSB21525 HDLC controller and the AMD AM79C30 ST controller with integral PCM codec for a single POTS port.

The CMX218 interfaces with a CMX605 Tone Generator and DTMF Receiver chip, which decodes incoming DTMF tones and generates certain call progress signals (e.g. busy tone) normally originating from an analog telephone exchange. The firmware translates the CMX605 data into ISDN D-channel commands and vice versa to support both incoming and outgoing calls. For the ISDN interface, D-channel commands sufficient for standard telephony applications are implemented. With the aid of a small amount of discrete circuitry, exchange battery voltage, ringing current, line reversal and off-hook detection are also supported, to complete the POTS interface.

The CMX218 also provides a data port that can drive a standard RS232 interface with the aid of a Maxim MAX238, or similar, level converter. The firmware provides support for incoming and outgoing data calls, RS232 auto-bauding from 9600bps to 115200bps, auto parity detection, RTS/CTS flow control, call clearing on loss of DTR, V.120 rate adaption, PPP async to sync conversion and a comprehensive set of Hayes commands (which facilitate the use of normal PC-based modem software). The CMX218 has dedicated outputs for visible indicators (LEDs) that can be used to provide information on the call status. Support for Multiple Subscriber Numbering is also included in the firmware.

The CMX218 can be configured either by means of keypad (DTMF) programming via the POTS port or by means of an extended Hayes command set via the RS232 port. Configuration parameters allow the user to change (for example) the format and cadence of the ringing signal, so as to facilitate use of the CMX218 in different countries. Each POTS and RS232 interface is able to configure the variables relevant to its own use.

An Application Programmer's Interface (API) is available and is described separately in Section 4.8. Further details are available on completion of a Non-Disclosure Agreement. Please contact MX-COM directly for further details.

The firmware and finite state machine embedded in the CMX218 have been used in products that have gained ETSI CTR3 approval.



## 4.1 Glossary

<b>ACCM</b>	Asynchronous Control Character Map
<b>API</b>	Application Programmer's Interface
<b>CIDCW</b>	Caller Identification During Call Waiting
<b>CLI</b>	Calling Line Identification
<b>CRC</b>	Cyclic Redundancy Check
<b>CTS</b>	Clear to Send
<b>DCD</b>	Data Carrier Detect
<b>DDI</b>	Direct Dialing Inwards
<b>DTE</b>	Data Terminal Equipment
<b>DTMF</b>	Dual Tone Multiple Frequency
<b>DTR</b>	Data Terminal Ready
<b>HDLC</b>	High Level Data Link Control
<b>IA5</b>	International Alphabet No 5
<b>IE</b>	Information Element
<b>ILFI</b>	ISDN Line Failure Indicator
<b>ISDN</b>	Integrated Services Digital Network
<b>LAPB</b>	Link Access Procedure - Balanced
<b>LAPD</b>	Link Access Procedure on the D-Channel
<b>LCGN</b>	Logical Channel Group Number
<b>LED</b>	Light Emitting Diode
<b>LLI</b>	Logical Link Identifier
<b>MFO</b>	Multiple Frame Operation
<b>MSN</b>	Multiple Subscriber Numbering
<b>NUA</b>	Network User Address
<b>NUI</b>	Network User Identification
<b>PAD</b>	Packet Assembler/Disassembler
<b>PC</b>	Personal Computer
<b>PCM</b>	Pulse Code Modulation
<b>POTS</b>	Plain Old (Analog) Telephone Service
<b>PPP</b>	Point to Point Protocol
<b>PVC</b>	Permanent Virtual Circuit
<b>RI</b>	Ring Indication
<b>RNR</b>	Receiver Not Ready
<b>RR</b>	Receiver Ready
<b>RTS</b>	Ready to Send
<b>SABM</b>	Set Asynchronous Balanced Mode
<b>SABME</b>	Set Asynchronous Balanced Mode Extended
<b>SLIC</b>	Subscriber Line Interface Circuit
<b>SPM</b>	Subscriber Pulse Metering
<b>SVC</b>	Switched Virtual Circuit
<b>TEI</b>	Terminal Endpoint Identifier

## 4.2 Initialization

On power-up, the CMX218 assumes its default values, which are factory programmed into the firmware. It then performs a self-test, during which all of the LED pins and the ILFI pin are held high for 3s. If the test is unsuccessful, the CMX218 remains in this condition.

If the test is successful, the CMX218 reads its preset values from the attached EEPROM and examines the state of the ISDN link (i.e. Layer 1) before commencing normal operation. On power-up, the ISDN link is deactivated, the POTS port is assumed to be on-hook, ringing is disabled and the RS232 port is in the Hayes command state.

## 4.3 ISDN Interface

Simultaneous voice and data calls are possible but only one of each type. If a call is active (e.g. ringing, connected or clearing down) and an incoming call of the same type (data or voice) is received, that call will be rejected with user busy as the cause. Incoming calls are firstly checked for other calls present, then the MSN is checked for validity, then the channel mapping, so that responses will be handled accordingly.

When channel mapping is enabled, outgoing calls will request the channel enabled. When not enabled, a request for any channel is made. If no free channels are available for outgoing calls, a locally generated busy tone is returned to the analog port or the appropriate Data Call Result Code is returned to the digital port.

### 4.3.1 Activation

Activation occurs in the following circumstances:

- The ISDN network activates.
- The device connected to the analog port goes off hook.
- The device connected to the data port sends a Hayes dial command.

The Terminal Endpoint Identifier (TEI) is either negotiated (Hayes register !C7 = 64) or fixed (Hayes register !C7 = 0 to 63). Line powering of the CMX218 is not supported.

The 'AR' indicator (LED8) toggles between high and low states when the CMX218 is powered up, and remains constantly low once the CMX218 identifies an activated ISDN line.

ISDN line power detection is not implemented and the CMX218 will negotiate a new TEI on any new network activation.

### 4.3.2 De-activation or Line Disconnection

De-activation or line disconnection causes the TEI to be removed. Upon re-connection the CMX218 will only be re-activated and request a new TEI when one of the conditions in the above section is met.

### 4.3.3 Line Failure Detection

If the line failure detection parameter is enabled (either via the POTS port or via the RS232 interface) the CMX218 will check that Layer 2 communications are active every sample period of 30 seconds. If Layer 2 communications are not active, the CMX218 will attempt to activate them. If they remain inactive for 2 sample periods, the line is deemed to have failed, so then the ILFI pin is set high and both RINGP1 and RINGN1 pins are set low. The CMX218 continues to attempt to activate the line and if it becomes active and stays active for 2 sample periods, then the ILFI pin is set low and RINGP1 and RINGN1 pins are restored to their default settings.

### 4.3.4 Incoming Calls

Incoming voice calls and calls from analog lines are directed to the analog port and all other incoming calls are directed to the RS232 port.

### 4.3.5 Multiple Subscriber Numbering

Multiple Subscriber Numbering (MSN) enables each POTS or RS232 port of the CMX218 to have its own telephone number. Up to 23 digits can be saved as the MSN for each port.

All incoming SETUP messages will be checked for the presence of a Called Party Number Information Element (IE). If one is present it is compared with the saved MSN number (if present), starting with the last digit of both numbers. Comparison continues until there are no more numbers in the MSN saved number or the incoming Called Party Number or there is a difference between the numbers. The MSN is said to match if the saved MSN and the incoming calls' Called Party Number are the same for the duration of the shorter number (i.e. if the digit '1' is saved and the received Called Party Number is 654321, then the MSN matches). If there is no saved MSN, the Called Party Number is ignored and call processing continues.

When there is a saved MSN and the Calling Party Number transmit is enabled, all outgoing call SETUP messages will contain a Calling Party Number Information Element.

**Note:**

1. When a CMX218 with MSN saved and Calling Party Number transmit enabled is connected to some exchanges, no dial tone is heard when going off-hook.
2. Disabling the Calling Party Number transmit will mean that the called party may not receive the Calling Line Identification (CLI), or if they do receive a CLI it will probably be the base number and not the number specific to the calling telephone.

### 4.3.6 Channel Mapping

It is possible to configure the CMX218 so that analog and/or digital ports will only originate calls to and respond to calls from a specific ISDN B-channel. This is a useful feature if, for example, you wish to have a Hunt Group on your ISDN line and only want one voice or data port to ring on an incoming call.

## 4.4 POTS Configuration

### 4.4.1 Configuration and Control via DTMF Keypad

Configuration can be carried out at any time by causing the POTS port to go off-hook and then immediately entering a configuration sequence of DTMF tones. The sequence signaled to the CMX218 will determine the configuration to be performed, as shown in the following table.

Configuration Sequence	Name	Description	Default
*02*#	Test watchdog	Puts the CMX218 into a permanent loop, not updating the external watchdog counter, so after 2s it should reset.	N/A
*90*#	Clear MSN	Clears any saved digits	N/A
*90*n#	Save Multiple Subscriber Number (MSN)	n = MSN (up to 23 digits)	Clear
*93*#	Clear country code	Country code is set to UK by default	N/A
*93*n#	Change country code	n = country code 0 = UK 1 = Belgium 2 = Rest of Europe	UK
*94*#	Clear channel mapping	Incoming calls on any channel are accepted (provided other parameters are valid e.g. MSN).	N/A
*94*n#	Enable channel mapping	Where n = 1 or 2 for the appropriate channel.	No channel map
*95*#	Disable Calling Party No. transmit	Outgoing call SETUP messages do not contain any Calling Party Number Information Elements.	N/A
*95*1#	Enable Calling Party No. transmit	Outgoing call SETUP messages contain Calling Party Number Information Element with number set to saved MSN (if a number is present).	Enabled
*96*#	Disable DDI transmit	Prevents digits being transmitted to the POTS port upon call connection.	N/A
*96*1#	Enable DDI transmit	Upon connection of a call on the POTS port, if there was a Called Party Number Information Element present in the incoming call setup message, the digits are sent as DTMF tones to the POTS port.	Disabled
*97*#	Disable line failure detection	Once the CMX218 is de-activated it stays de-activated until the network re-activates it or an outgoing call needs to be made.	N/A
*97*1#	Enable line failure detection	The CMX218 checks to see if the ISDN line is activated and Layer 2 communications can be made. It then sets the ILFI pin accordingly.	Disabled
*9**1234567890#	Initialize all configurations.	Resets all of the configuration variables back to their default values.	N/A

Once the '\*' has been recognized, each digit pressed is then checked for validity as a configuration sequence. If any digit pressed is not a valid configuration digit, all digits pressed so far will be transmitted to the network in INFORMATION messages as Keypad Information Elements, until a '#' is entered (with the exception of '\*#' being entered, see Keypad Operation below). If the first four digits received are a valid configuration sequence then the configuration mode is entered. When a valid configuration has been completed the CMX218 will send a single DTMF tone to the POTS port. If a valid configuration sequence is received but subsequent digits are invalid, then subsequent digits entered will be ignored and two DTMF tones will be sent to the POTS port.

If the port goes on-hook part way through configuration, it will cause any digits received so far to be ignored. Configurations can be performed consecutively with the exception of the test function (where the attached handset must be replaced immediately after the configuration has been audibly signaled to the POTS port). All configurations entered will be retained after a power-down as they are stored in the external EEPROM.

## 4.5 POTS Operation

### 4.5.1 Keypad Operation

The CMX218 supports ISDN keypad messages for control of Network Supplementary services either before or during call establishment. When dialing a number (i.e. off-hook and dial tone audible on POTS port), or if a call has been disconnected by the network but the POTS port has not yet gone on-hook, any keypad string entered will be sent to the network as 'Keypad Information Elements' within INFORMATION messages.

Keypad strings are defined as the following sequences of digits, with the exception of the configuration strings defined in the previous section:

\*...#

\*#...#

#...#

When a call is connected, pressing the recall key results in all subsequent key presses being sent to the network as 'Keypad Information Elements' within INFORMATION messages, until the handset is replaced. The tones generated by the key presses are also passed down the B-channel, so the remote user will be able to hear them.

### 4.5.2 Incoming POTS Calls

An incoming POTS call is identified by the Bearer Capability Information Element of the SETUP message being set to 'Speech' or '3.1kHz Audio'. The call will be routed to the POTS port if it satisfies the following three conditions:

- The port is on-hook.
- The MSN saved for the port matches the Called Number in the incoming SETUP message, or no MSN is specified for the port, or there is no Called Number in the SETUP message. See Section 4.3.5 for details of POTS port MSN selection.
- The ISDN B-channel on which the call is placed (as indicated in the SETUP message) is compatible with the channel mapping configuration for the port. See Section 4.3.6 for details of POTS port channel mapping selection.

When the call is routed to the port, the ringing signal for that port will be applied by means of the RINGP1 and RINGN1 pins.

The call is answered when the port with ringing signal goes off-hook. The ringing signal is then stopped and the ISDN call is connected to that port.

### 4.5.3 Outgoing POTS Calls

Outgoing calls are initiated when the POTS port goes off-hook. An ISDN SETUP message is sent to the network with the Bearer Capability Information Element set to 'Speech'. The dial tone presented by the network on that ISDN B-channel that was selected by channel mapping (See Section 4.3.6), will be routed to the POTS port.

When DTMF tones are received from the POTS port, they are sent to the network either as Called Party Number or Keypad Information Elements. Keypad Information Elements are discussed in Section 4.5.1.

Receipt of a valid DTMF tone will prompt its conversion to IA5 coded digits, as shown in the following table (IA5 hex digits are in brackets). If the first valid digit to be received is a '\*' then the configuration mode is entered and subsequent digits will be monitored and saved as indicated in Section 4.4.1. If the first tone received is not a '\*' or '#' (See Section 4.5.1) that digit and all subsequent digits will be passed to the network in an INFORMATION message as a Called Party Number Information Element. Digits received before the network has returned the SETUP ACK message are saved. Upon receipt of the SETUP ACK any saved digits will be transmitted.

The DTMF tone mapping is as shown below:

Low Group (Hz)	High Group (Hz)			
	1209	1336	1477	1633
697	1 (31)	2 (32)	3 (33)	A (not used)
770	4 (34)	5 (35)	6 (36)	B (not used)
852	7 (37)	8 (38)	9 (39)	C (not used)
941	* (2A)	0 (30)	# (23)	D (not used)

Once the network has indicated that the full number has been received, no further digits will be sent to the network. All tones and announcements from the network (e.g. ringing, NU, busy etc) and audio (if the call is connected) will be routed to the POTS port, until that port goes on-hook.

### 4.5.4 Connected Calls

Once a call is connected to the analog port, whether it was incoming or outgoing, a LED indicator pin is set high to indicate that the call is connected. See Section 4.9.1 for details of the LED indicator pins. Once the call is disconnected, either by receipt of a DISCONNECT message from the network or an on-hook indication, that LED indicator pin is set low.

During a call, if a Recall (i.e. a line break of appropriate length) is received from the POTS port, the CMX218 will start to look for DTMF tones received on the POTS port. Any tones received will then be sent to the network in ISDN INFORMATION messages, as Keypad Information Elements.

### 4.5.5 Call Clearing

The call is cleared either by the port going on-hook or by the ISDN network. Note that the ISDN B-channel that was being used is not released until the POTS port has gone on-hook.

## 4.6 Data Configuration

### 4.6.1 Hayes Command Set

The following Hayes commands are supported:

A	- Answers a call
D	- Dial
E	- Echo Hayes commands or not
H	- Hang-up
I3	- Firmware part number
Q	- Result code display
V	- Result code form
X	- Result code set
&C	- Carrier detect
&D	- Data terminal ready
&F	- Load factory default
&K	- Flow control
&V	- View active and stored profiles
&Z	- Store directory number

Valid Hayes commands are responded to with an 'OK' result code. Invalid commands are rejected with an 'ERROR' result code.

If when entering an AT command, no command or register name suffix is supplied, a suffix of zero is assumed. If when changing a register value, no value is supplied a value of zero or an empty string is assumed: e.g. AT\$0=<CR> is equivalent to AT\$0=0<CR>.

If a data call is active when a command is entered, the command will be processed. The ATO command will respond 'OK', but will not then enter the data state: it will stay in the command state.

Where commands set a parameter, these are saved in external EEPROM if they are entered correctly.

The CMX218 will auto-baud and auto-parity on Hayes commands at the following speeds:

- 9600bps
- 19200bps
- 38400bps
- 57600bps
- 115200bps

The auto-bauding process looks for the characters 'AT' or 'at' either as 8 bits no parity or 7 bits even, or odd, parity. An error in the auto-bauding process results in auto-bauding being restarted.

After auto-bauding successfully, the CMX218 waits to receive a complete Hayes command line before processing it. Embedded spaces are ignored and the case (upper or lower) of characters after the 'AT' does not matter. The command line is terminated by <CR>, by 250 characters (not including the 'AT') or by a time-out (from successful auto-bauding on an 'AT') of 180 seconds.

All characters in the Hayes command, including the 'AT' and <CR> terminator are echoed (if E1 is set) by the CMX218 as they are sent by the DTE.

Receipt of a backspace will cause the CMX218 to send a "back space, space, back space" sequence of characters to the DTE to allow the terminal to clear its screen of the last character. Also the last character received will be discarded unless the last characters received were the 'AT' used for auto-bauding, i.e. the 'AT' is never deleted.

The escape sequence '+++ ' (with Guard Time = 1s before and after the sequence) will cause the CMX218 to enter the command state from the data state and to return on 'OK' response. Sending an ATO command will be ignored, i.e. the CMX218 remains in the command state.

The following is a more detailed description of the Hayes commands listed above:

### A (Answer)

Format: ATA<CR>

Causes the CMX218 to answer an incoming data call, by sending a CONNECT message to the network. If a CONNECT ACK is received the CMX218 enters the data state after returning a 'CONNECT XXX' result code to the DTE on the RS232 port (where the XXX is the speed in baud). If a RELEASE, RELEASE COMPLETE or DISCONNECT message is received a 'NO CARRIER' result code is returned. The command is not valid if there is no incoming call and it will return 'ERROR'.

### D (Dial)

Format: ATD{DN}<CR>

Format: ATDT{DN}<CR>

Format: ATDP{DN}<CR>

{DN} is a directory number of up to 23 ASCII characters from 0..9, \* and #. This form of the ATD command causes an outgoing SETUP message to be sent to the network with a Called Party Number Information Element which contains the digits included in the command. Any commands that follow this command are ignored.

If the CMX218 receives any character from the DTE after an ATD command, which causes a SETUP message to be sent to the network, and before the call is connected, the attempt to make a call is abandoned, i.e. a DISCONNECT message will be sent to the network and a 'NO CARRIER' result code returned.

Calls are established with the D command, irrespective of the state of the DTR pin. The result code response is either:

'CONNECT' - call successful. The CMX218 will automatically enter the data state.  
 'NO CARRIER' - call rejected by the remote user or the network  
 'NO DIALTONE' - ISDN link down  
 'BUSY' - remote user busy and other causes

Calls are cleared in the following way:

- i. The remote end or network clears the call by sending a DISCONNECT message or the ISDN line fails/is removed: 'NO CARRIER' is sent to DTE.
- ii. DTR is dropped (with a de-bounce period of 50ms) by DTE causing the CMX218 to send a DISCONNECT message to the network and enter the disconnect state, awaiting a RELEASE COMPLETE from the network. The CMX218 sends the 'OK' response when clearing of the ISDN call is complete i.e. RELEASE and RELEASE COMPLETE messages have been transmitted across the network, (dependant upon the state of &D command).
- iii. The DTE issues the escape sequence '+++ '(with Guard Time = 1s before and after the sequence), receives an 'OK' response and then issues the Hang-up command (see section on H command below). The CMX218 sends the 'OK' response when clearing of the ISDN call is complete.

Incoming calls are indicated by a 'RING' result code. The call is automatically answered if S0 = 1 or more. If S0 = 0 an ATA command must be entered, then a CONNECT message is sent to the network.

### E (Echo)

Format: ATEn<CR>

<u>Suffix n</u>	<u>Description</u>
0	Echo off
1 (default)	Echo on

This command tells the CMX218 whether or not to echo the characters received from the DTE when in command mode. When echo is on, all non-control characters received from the DTE are echoed back to it.

### H (Hang-up)

Format: ATH<CR>

Causes the CMX218 to clear the data call in progress. The command is not valid if there is no data call in progress but always returns an 'OK' result code. It is only valid in the command state when a data call is in operation, when it will send a DISCONNECT message to the network. Upon receipt of RELEASE, a RELEASE COMPLETE is transmitted to the network and 'OK' returned to the DTE.



**I3 (Firmware Part Number)**

Format: ATI3&lt;CR&gt;

Causes the CMX218 to return the part code and revision level to the DTE:

"CMX218: Vn.nn" where n.nn = version number

**Q (Result Code Display)**

Format: ATQn&lt;CR&gt;

<u>Suffix n</u>	<u>Description</u>
0 (default)	Result codes enabled
1	Result codes suppressed
2	Result codes are suppressed when an incoming call is received, otherwise enabled

**V (Result Code Form)**

Format: ATVn&lt;CR&gt;

<u>Suffix n</u>	<u>Description</u>
0	Result codes sent as numbers (see Data Call Result Codes below)
1 (default)	Result codes sent as words. This instructs the CMX218 to send the result codes as words or numbers to the DTE.

**X (Result Code Set)**

Format: ATXn&lt;CR&gt;

<u>Suffix n</u>	<u>Description</u>
0	0..4
1	0..4, 12, 14, 18, 28, 31
2	0..4, 12, 14, 18, 28, 31
3 (default)	0..4, 6, 7, 12, 14, 18, 28, 31
4	0..4, 6, 7, 12, 14, 18, 28, 31

This command causes the CMX218 to limit the data call result codes used to a given set. See Data Call Result Codes below for a list of codes and their meanings.

**Data Call Result Codes**

The data call result codes supported are:

<u>Numbers</u>	<u>Words</u>
0	'OK'
1	'CONNECT'
2	'RING'
3	'NO CARRIER'
4	'ERROR'
6	'NO DIALTONE'
7	'BUSY'
12	'CONNECT 9600'
14	'CONNECT 19200'
18	'CONNECT 57600'
28	'CONNECT 38400'
31	'CONNECT 115200'

**&C (Carrier Detect)**

Format: AT&amp;Cn&lt;CR&gt;

Changes the operation of the RS232 DCD (Data Carrier Detect) signal.

<u>Suffix n</u>	<u>Description</u>
0	Ignore connection status; keep DCD high and LED3 pin low (i.e. ON).
1 (default)	DCD tracks the status of the data connection, raised when the call is connected, lowered when cleared. LED3 pin tracks the inverse status of the DCD pin (i.e. high when data connection is cleared).

**&D (Data Terminal Ready)**

Format: AT&amp;Dn&lt;CR&gt;

Determines the CMX218 operation if DTR is lowered during a call.

<u>Suffix n</u>	<u>Description</u>
0	No action
2 (default)	B or D-channel data call is cleared and auto-answer is suspended until DTR is raised again.

If &D2 is set and DTR is low when an incoming call is received, the call is accepted and Ring Indication is sent to the DTE. If an incoming call has been accepted and &D2 is set when DTR is lowered, the call is cleared.

**&F (Load Factory Profile)**

Format: AT&amp;F&lt;CR&gt;

Sets the following commands and registers to their default values. It does not change the %A !B, !C registers or the &Z command.

Commands:	E	Q	V	X	&C	&D	&K
Registers:	S0	S37	%B	%D	%E	%L	

Format: AT&amp;F9&lt;CR&gt;

Sets all commands and registers to the default values and resets LED indicator and RS232 interface pins accordingly.

**&K (Flow Control)**

Format: AT&amp;Kn&lt;CR&gt;

Indicates the method of flow control to be used between the CMX218 and the DTE when in the data state. There is no flow control when the CMX218 is in the command state.

<u>Suffix n</u>	<u>Description</u>
0	No flow control
3 (default)	Bi-directional RTS/CTS signals

Flow control is only active when in an active data call, i.e. not when dealing with Hayes commands.

Flow control is applied to the DTE in the following situations:

- i. The remote end signals flow control (the mechanism is protocol dependent).
- ii. Several buffers of data are held waiting transmission across ISDN.

Flow control is applied to the remote end (the mechanism is protocol dependent) if excessive data is held pending transmission to the DTE, so as to prevent local buffer overflow.

**&V (View Active/Stored Profiles)**

Format: AT&amp;V&lt;CR&gt;

Causes the CMX218 to display the following command and register values for the stored profile:

Commands:	E	Q	V	X	&C	&D	&K	&Z	
Registers:	S0	S37	%A	!C	%E	%B	%D	%L	!B

**&Z (Store Directory Number)**

Format: AT&amp;Z3={DN}&lt;CR&gt;

This command instructs the CMX218 to store a directory number. The stored directory number is then used by the X.25 call setup as the 'Calling NUA'.

A directory number consists of a string of characters from the set 0..9, \*, and #. The '=' character can be omitted. Where a store number is entered, only the value 3 will give an 'OK' response. The contents of the &Z directory number are displayed by using the &V0 command. Up to 20 digits can be saved. The number must be in quotes. e.g. at&z3 ='12345'.

## 4.6.2 Hayes Register Set

In addition to the commands, there are a group of registers for which data is entered in the following format: AT{register}={value}<CR>. The following Hayes registers are supported:

S0	- Number of rings on which to auto- answer
S37	- Maximum rate adaption speed
%A2	- B/D - channel protocol
%E8	- V.120 MFO mode selection
!C4	- B1 - channel configuration
!C5	- B2 - channel configuration
!C6	- Multiple Subscriber Numbering
!C7	- TEI selection
!C8	- ISDN Line Failure Detection enable/disable

The following is a more detailed description of the Hayes registers listed above:

### S0 (Rings on Which to Auto-answer a Data Call)

<u>Range</u>	<u>Default</u>	<u>Description</u>
0 to 255	0	If set to 0 auto-answering will be disabled. Any other value will cause one 'RING' result code to be sent to the DTE after which the call is answered.

### S37 (Maximum Rate Adaption Speed)

This forces the baud rate when handling incoming calls, to that defined by the S37 register contents, provided auto-answer is set. Once a call is terminated the baud rate remains that set by the S37 register.

<u>Value</u>	<u>Rate (baud)</u>
0 (default)	Same as last AT speed
9	9600
12	19200
13	38400
18	57600
31	115200

### %A2 (CSD Protocol)

Selects the protocol to be used for the circuit switched data calls. Note that %A2 cannot be changed while a B or D-channel call is active.

<u>Value</u>	<u>Description</u>
2 (default)	V.120 Rate Adaption on B-channel.
3	Voice Calls.
15	PPP.
20	Transparent protocol.

#### 4.6.2.1 V.120 Parameters

### %E8 (Multiple Frame Operation Mode Selection)

In Multiple Frame Operation (MFO) mode, frames are acknowledged and retransmitted if errors occur.

<u>Value</u>	<u>Description</u>
0	MFO mode on.
1(default)	MFO mode off.

### 4.6.2.2 Basic Configuration Parameters

#### !C4 (B1 Channel Mapping)

Enables data calls to be made and accepted on the B1-channel. If !C5 is set to 0 the outgoing call SETUP message will contain a Channel Identification Information Element set to B1-channel only.

<u>Value</u>	<u>Description</u>
0	Incoming data calls on the B1-channel are rejected with 'channel not acceptable' as the cause.
4 (default)	Incoming data calls on the B1-channel are accepted provided no other data call is present.

#### !C5 (B2 Channel Mapping)

Enables data calls to be made and accepted on the B2-channel. If !C4 is set to 0 the outgoing call SETUP message will contain a Channel Identification Information Element set to B2-channel only.

<u>Value</u>	<u>Description</u>
0	Incoming data calls on the B2-channel are rejected with 'channel not acceptable' as the cause.
4 (default)	Incoming data calls on the B2-channel are accepted provided no other data call is present.

**Note:** If both !C4 and !C5 =0 no data calls will be made or received.

#### !C6 (MSN Directory Number)

Also refer to ISDN MSN (Section 4.3.5).

If there is a number saved in this register upon receipt of an incoming data call, the CMX218 will check for the presence of a Called Party Number Information Element. If present it will compare the number with that saved in the !C6 register. If they match, the call will be accepted, i.e. a 'RING' indication (RI pin is raised, then lowered after 3s) is returned to the DTE. If the Called Party Number Information Element and saved MSN do not match, the call is ignored. The command is entered as follows:

```
AT!C6="nnnn"<CR>    if no digits are present within the quotes, the MSN is cleared.
                    Up to 23 digits may be entered.
```

#### !C7 (TEI selection)

Selects the fixed or negotiated TEI used on the ISDN link. Note that the value of !C7 only takes effect when the ISDN interface goes from de-activated to activated.

<u>Value</u>	<u>Description</u>
0-63	Fixed TEI, 0 to 63.
64 (default)	Negotiated TEI.

#### !C8 (ISDN Line Failure Detection enable/disable)

Enables or disables Line Failure Detection. (Refer to Section 4.3.3).

<u>Value</u>	<u>Description</u>
0	Line Failure Detection disabled.
1 (default)	Line Failure Detection enabled.

## 4.7 Data Operation

### 4.7.1 Incoming B-Channel Data Calls

All incoming data calls which have valid channel use and MSN are directed to the data port and cause 'RING' followed by the digits of the calling party number and the calling party subaddress (if received in the SETUP message) to be returned to the DTE. The Ring Indicator (RI) pin is also raised, and then lowered after 3s. 'RING' text and the raising of RI for 3s is repeated every 6s until the call is cleared or answered, provided S0=0. If S0=1 then only one RING will appear at the DTE and the RI line will be raised only once, as a CONNECT message will be sent to the network.

### 4.7.2 Outgoing B-Channel Data Calls

Outgoing calls are requested specifying either B-channel unless channel mapping is enabled via !C4 and !C5 registers. The SETUP message is sent without High Layer Compatibility or Low Layer Compatibility and with the following Bearer Capability:

- CCITT coding standard
- Unrestricted digital
- Circuit mode
- 64k information transfer rate

If there is a saved MSN in !C6 register all outgoing call SETUP messages will contain the saved number in a Calling Party Number Information Element.

### 4.7.3 Connected Calls

Once a call is connected to the digital port, whether it was incoming or outgoing, the DCD pin is set high to indicate that the call is connected (providing &C0 command is not given). If the DCD pin is set high, the LED3 pin will be set low.

### 4.7.4 Call Clearing

The call is cleared either by the ATH command or by the ISDN network. When the call has been cleared, the DCD pin is set low and the LED3 pin is set high (providing the &C0 command is not given).

## 4.8 Application Programmer's Interface

Details of this will be supplied to customers under a Non-Disclosure Agreement.

The following Memory Map indicates the main code areas used on the CMX218:

Function	Start Hex Address	End Hex Address
Code Space	000 000	01F FFF
External RAM	020 000	03F FFF
API area	0C0 000	0EF FFF
AMD79C30 ISDN Interface Chip	0F0 000	0F0 0FF
PSB21525 HDLC Driver Chip	0F0 100	0F0 1FF
Reserved	0F0 200	0FF FFF

## 4.9 Hardware Description

### 4.9.1 LED Status Indicators (LED1 to LED9, and ILFI)

**LED1 (HK1)** is low when the POTS port is off-hook, high when on-hook.

**LED2 (AA)** indicates that register S0 has been set to 1 or more when low and set to 0 when high (RS232 Auto Answer indication).

**LED3 (DCD)** is low when a call is connected via the RS232 port (if &C0 is set to '1'), high when a call is not connected to this port.

**LED4 (RTS)** is low if RTS on the RS232 port is active and vice versa, indicating flow control (RS232 Ready To Send).

**LED5 (RXD)** is low if data is being sent to the DTE (RS232).

**LED6 (TXD)** is low if data is being received from the DTE (RS232).

**LED7 (DTR)** is low if the de-bounced DTR line on the RS232 port is active and vice versa.

**LED8 (AR)** is pulsed high and low until the ISDN line is activated, when it remains low constantly.

**LED9 (CN1)** is high when the POTS port is connected to the ISDN network, low when not connected.

**ILFI** is high when an ISDN Link Failure is Indicated, low when the link is operational.

The functions of the LED and ILFI indicators are set out in the table below:

Pin No.	Designation	POTS port	RS232 port
12	LED1	Off-Hook	~
13	LED2	~	Auto-Answer
14	LED3	~	Carrier Detect
15	LED4	~	Ready to Send
16	LED5	~	Receive Data
17	LED6	~	Transmit Data
18	LED7	~	Data Terminal Ready
19	LED8	ISDN Line Activated	ISDN Line Activated
21	LED9	Call Connected	~
54	ILFI	ISDN Line Failure Indicator	ISDN Line Failure Indicator

## 5. Application Notes

### 5.1 General

The CMX218 is intended for use as part of an ISDN chipset. The MX-COM recommended hardware implementation contains the following elements (refer to Figure 3):

'S' bus interface via RJ45 socket.

RJ11 analog telephone socket and analog circuitry.

ISDN line transformer.

AMD79C30 S-interface controller.

Single asynchronous RS232 interface via 9-way or 25-way D-type connector.

64K bytes external RAM.

16K Non-volatile memory.

Ten processor controlled LED indicator signals.

HDLC drivers for the 2 ISDN B-channels, both channels can be used for data transfer.

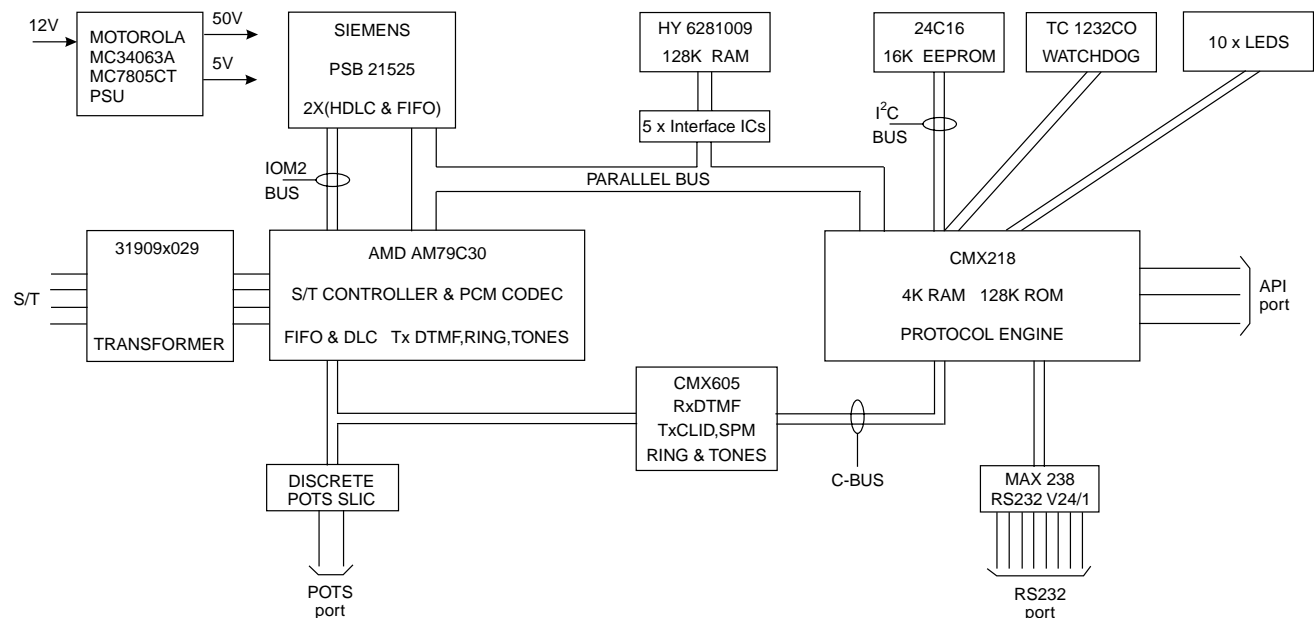

Figure 3: Application Block Diagram

### 5.2 Approvals

The firmware and finite state machine embedded in the CMX218 have been used in products that have gained ETSI CTR3 approval.

## 6. Performance Specification

### 6.1 Electrical Performance

#### 6.1.1 Absolute Maximum Ratings

Exceeding these maximum ratings can result in damage to the device.

	Min.	Max.	Units
Supply ( $AV_{DD} - AV_{SS}$ ), ( $DV_{DD0} - DV_{SS0}$ ), ( $DV_{DD1} - DV_{SS1}$ )	-0.3	7.0	V
Voltage on any pin to $AV_{SS}$ , $DV_{SS0}$ or $DV_{SS1}$	-0.3	$V_{DD} + 0.3$	V
Current into or out of any $V_{DD}$ or $V_{SS}$ pin	-30	100	mA
Current into or out of any other pin	-20	10	mA
<b>S1 Package (QFP)</b>			
Total Allowable Power Dissipation at $T_{AMB} = 25^{\circ}\text{C}$		1300	mW
Derating above $25^{\circ}\text{C}$		17	mW/ $^{\circ}\text{C}$ above $25^{\circ}\text{C}$
Storage Temperature	-55	125	$^{\circ}\text{C}$
Operating Temperature	-40	85	$^{\circ}\text{C}$

#### 6.1.2 Operating Limits

Correct operation of the device outside these limits is not implied.

	Notes	Min.	Max.	Units
Supply: ( $AV_{DD} - AV_{SS}$ ) ( $DV_{DD0} - DV_{SS0}$ ) ( $DV_{DD1} - DV_{SS1}$ )		2.7	5.5	V
Operating Temperature		-40	+85	$^{\circ}\text{C}$
32MHz Xtal Frequency Tolerance		-100	+100	ppm



### 6.1.3 Operating Characteristics

*Details in this section represent design target values and are not currently guaranteed.*

For the following conditions unless otherwise specified:

Xtal Frequency = 32MHz  $\pm$ 100ppm, AV<sub>DD</sub> = DV<sub>DD0</sub> = DV<sub>DD1</sub> = 3.0V to 5.0V, T<sub>AMB</sub> = - 40°C to +85°C.

	Notes	Min.	Typ.	Max.	Units
<b>DC Parameters</b>					
I <sub>DD</sub> (total, operational)	1		25.0	45.0	mA
I <sub>DD</sub> (total in HALT mode)	1		13.0	26.0	mA
I <sub>DD</sub> (total in IDLE mode)	1			12.0	mA
<b>Digital Interface</b>					
Input logic "1" level		70%			V <sub>DD</sub>
Input logic "0" level				30%	V <sub>DD</sub>
Input leakage current (V <sub>IN</sub> = 0 to DV <sub>DD</sub> )		-10.0		+10.0	μA
Output logic "1" level (I <sub>OH</sub> = 120μA)		V <sub>DD</sub> -1.0			V
Output logic "0" level (I <sub>OL</sub> = 360μA)				400	mV
Input or Output leakage current (V <sub>OUT</sub> = V <sub>DD</sub> )				10	μA
<b>Xtal/Clock Input</b>					
'High' pulse width (t <sub>WXH</sub> )	2	10		125	ns
'Low' pulse width (t <sub>WXL</sub> )	2	10		125	ns
Risetime (t <sub>XR</sub> )	2			10	ns
Falltime (t <sub>XF</sub> )	2			10	ns
Period (t <sub>CYK</sub> )	2, 3	31.2468		31.2531	ns

#### Notes:

1. Not including any current drawn by external circuitry.
2. Timing for an external input to the XTAL pin.
3. A fundamental cut crystal is recommended.

## 6.1.3.1 Timing Diagrams

## (1) Read Operation

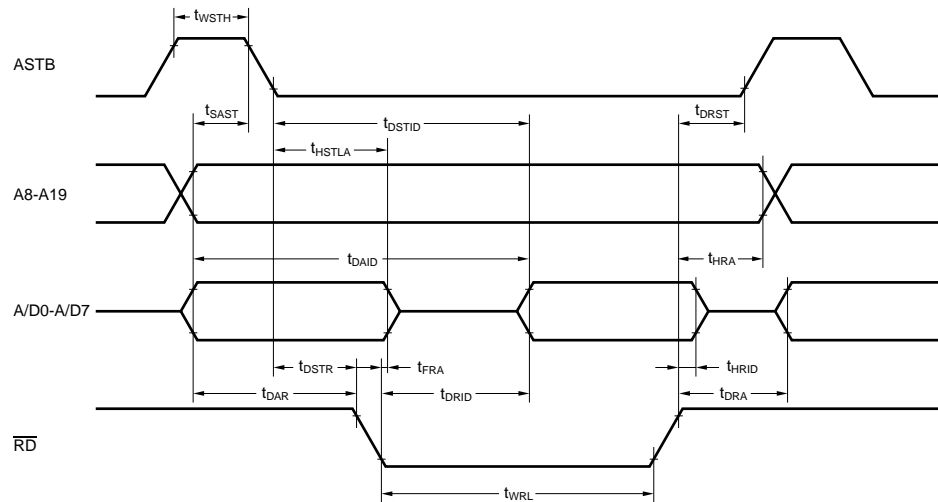

## (2) Write Operation

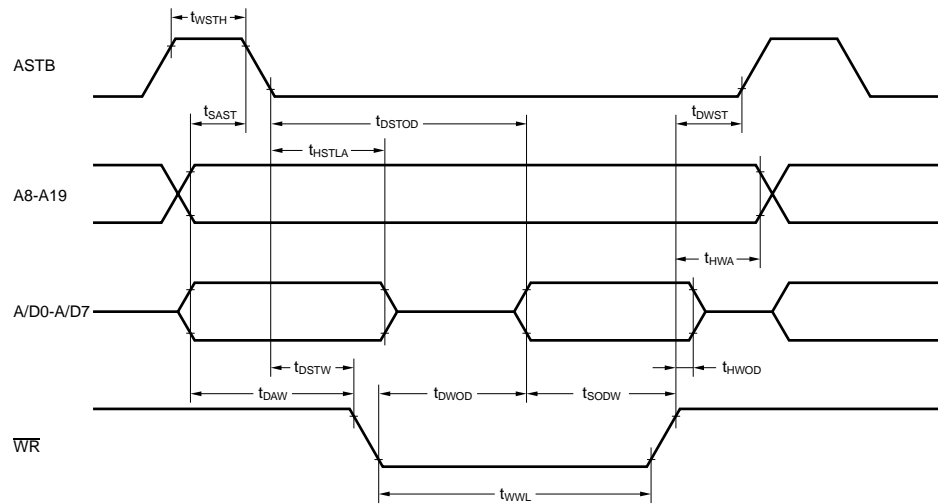
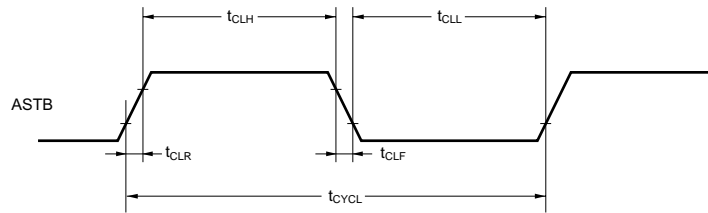
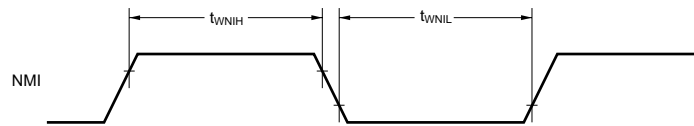

Figure 4: External Memory Access Timing

## CLOCK OUTPUT TIMING



## INTERRUPT INPUT TIMING



## RESET INPUT TIMING

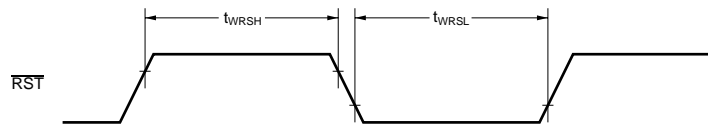

## EXTERNAL CLOCK TIMING

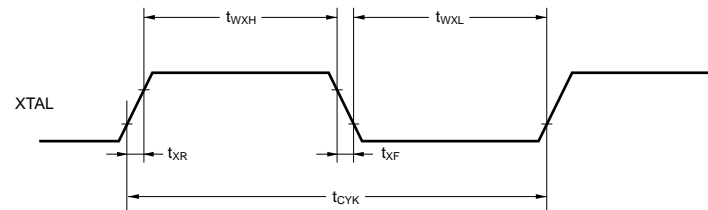

Figure 5: Miscellaneous Timing

### 6.1.3.2 AC Timing Parameters

For the following conditions unless otherwise specified:

Xtal Frequency = 32MHz,  $V_{DD} = DV_{DD0} = DV_{DD1} = 3.0V$  to  $5.0V$ ,  $T_{AMB} = -40^{\circ}C$  to  $+85^{\circ}C$ .

#### 6.1.3.2.1 Read/Write operation (1/2)

Where:  $T = t_{CYK}$  (system clock cycle time)

$a = 1$  (during address wait), otherwise, 0

$n =$  Number of wait states ( $n = 2$ )

Parameter	Symbol	Conditions	Min.	Max.	Units
Address setup time	$t_{SAST}$	$V_{DD} = +5.0V \pm 10\%$	$(0.5 + a) T - 15$ $(0.5 + a) T - 31$		ns ns
ASTB high-level width	$t_{WSTH}$	$V_{DD} = +5.0V \pm 10\%$	$(0.5 + a) T - 17$ $(0.5 + a) T - 40$		ns ns
Address hold time to (ASTB $\downarrow$ )	$t_{HSTLA}$	$V_{DD} = +5.0V \pm 10\%$	$0.5T - 24$ $0.5T - 34$		ns ns
Address hold time (to $\overline{RD} \uparrow$ )	$t_{HRA}$		$0.5T - 14$		ns
Delay from address to $\overline{RD} \downarrow$	$t_{DAR}$	$V_{DD} = +5.0V \pm 10\%$	$(1 + a) T - 9$ $(1 + a) T - 15$		ns ns
Address float time (to $\overline{RD} \downarrow$ )	$t_{FRA}$			0	ns
Delay from address to data input	$t_{DAID}$	$V_{DD} = +5.0V \pm 10\%$		$(2.5 + a + n) T - 37$ $(2.5 + a + n) T - 52$	ns ns
Delay from ASTB $\downarrow$ to data input	$t_{DSTID}$	$V_{DD} = +5.0V \pm 10\%$		$(2 + n) T - 40$ $(2 + n) T - 60$	ns ns
Delay from $\overline{RD} \downarrow$ to data input	$t_{DRID}$	$V_{DD} = +5.0V \pm 10\%$		$(1.5 + n) T - 50$ $(1.5 + n) T - 70$	ns ns
Delay from ASTB $\downarrow$ to $\overline{RD} \downarrow$	$t_{DSTR}$		$0.5T - 9$		ns
Data hold time (to $\overline{RD} \uparrow$ )	$t_{HRID}$		0		ns
Delay from $\overline{RD} \uparrow$ to address active	$t_{DRA}$	$V_{DD} = +5.0V \pm 10\%$ After program is read After program is read $V_{DD} = +5.0V \pm 10\%$ After data is read After data is read	$0.5T - 8$ $0.5T - 12$ $1.5T - 8$ $1.5T - 12$		ns ns ns ns
Delay from $\overline{RD} \uparrow$ to ASTB $\uparrow$	$t_{DRST}$		$0.5T - 17$		ns
$\overline{RD}$ low-level width	$t_{WRL}$	$V_{DD} = 5.0V \pm 10\%$	$(1.5 + n) T - 30$ $(1.5 + n) T - 40$		ns ns
Address hold time (to $\overline{WR} \uparrow$ )	$t_{HWA}$		$0.5T - 14$		ns
Delay from address to $\overline{WR} \downarrow$	$t_{DAW}$	$V_{DD} = +5.0V \pm 10\%$	$(1 + a) T - 5$ $(1 + a) T - 15$		ns ns
Delay from ASTB $\downarrow$ to data output	$t_{DSTOD}$	$V_{DD} = +5.0V \pm 10\%$		$0.5T + 19$ $0.5T + 35$	ns ns
Delay from $\overline{WR} \downarrow$ to data output	$t_{DWOD}$			$0.5T - 11$	ns
Delay from ASTB $\downarrow$ to $\overline{WR} \downarrow$	$t_{DSTW}$		$0.5T - 9$		ns

## 6.1.3.2.2 Read/Write operation (2/2)

Parameter	Symbol	Conditions	Min.	Max.	Units
Data setup time (to $\overline{WR}$ $\uparrow$ )	$t_{SODW}$	$V_{DD} = +5.0V \pm 10\%$	$(1.5 + n)T - 30$ $(1.5 + n)T - 40$		ns ns
Data hold time (to $\overline{WR}$ $\uparrow$ ) <sup>Note 1</sup>	$t_{HWOD}$	$V_{DD} = +5.0V \pm 10\%$	$0.5T - 5$ $0.5T - 25$		ns ns
Delay from $\overline{WR}$ $\uparrow$ to $\overline{ASTB}$ $\uparrow$	$t_{DWST}$		$0.5T - 12$		ns
$\overline{WR}$ low-level width	$t_{WWL}$	$V_{DD} = +5.0V \pm 10\%$	$(1.5 + n)T - 30$ $(1.5 + n)T - 40$		ns ns

**Note:**

1. Hold time includes the time during which  $V_{OH1}$  and  $V_{OL1}$  are held under the load conditions of  $C_L = 50$  pF and  $R_L = 4.7$  k $\Omega$ .

## 6.1.3.2.3 Miscellaneous timing

Where:  $T = t_{CYK}$  (system clock cycle time)  
 $a = 1$  (during address wait), otherwise, 0  
 $n =$  Number of wait states ( $n = 2$ )

Parameter	Symbol	Conditions	Min.	Max.	Units
ASTB cycle time	$t_{CYCL}$		$nT$		ns
ASTB low-level width	$t_{CLL}$	$V_{DD} = +5.0V \pm 10\%$	$0.5 t_{CYCL} - 10$ $0.5 t_{CYCL} - 20$		ns ns
ASTB high-level width	$t_{CLH}$	$V_{DD} = +5.0V \pm 10\%$	$0.5 t_{CYCL} - 10$ $0.5 t_{CYCL} - 20$		ns ns
ASTB rise time	$t_{CLR}$	$V_{DD} = +5.0V \pm 10\%$		10 20	ns ns
ASTB fall time	$t_{CLF}$	$V_{DD} = +5.0V \pm 10\%$		10 20	ns ns
NMI low-level width	$t_{WNIL}$		10		$\mu s$
NMI high-level width	$t_{WNIH}$		10		$\mu s$
$\overline{RST}$ low-level width	$t_{WRSL}$		10		$\mu s$
$\overline{RST}$ high-level width	$t_{WRSH}$		10		$\mu s$

## 6.2 Packaging

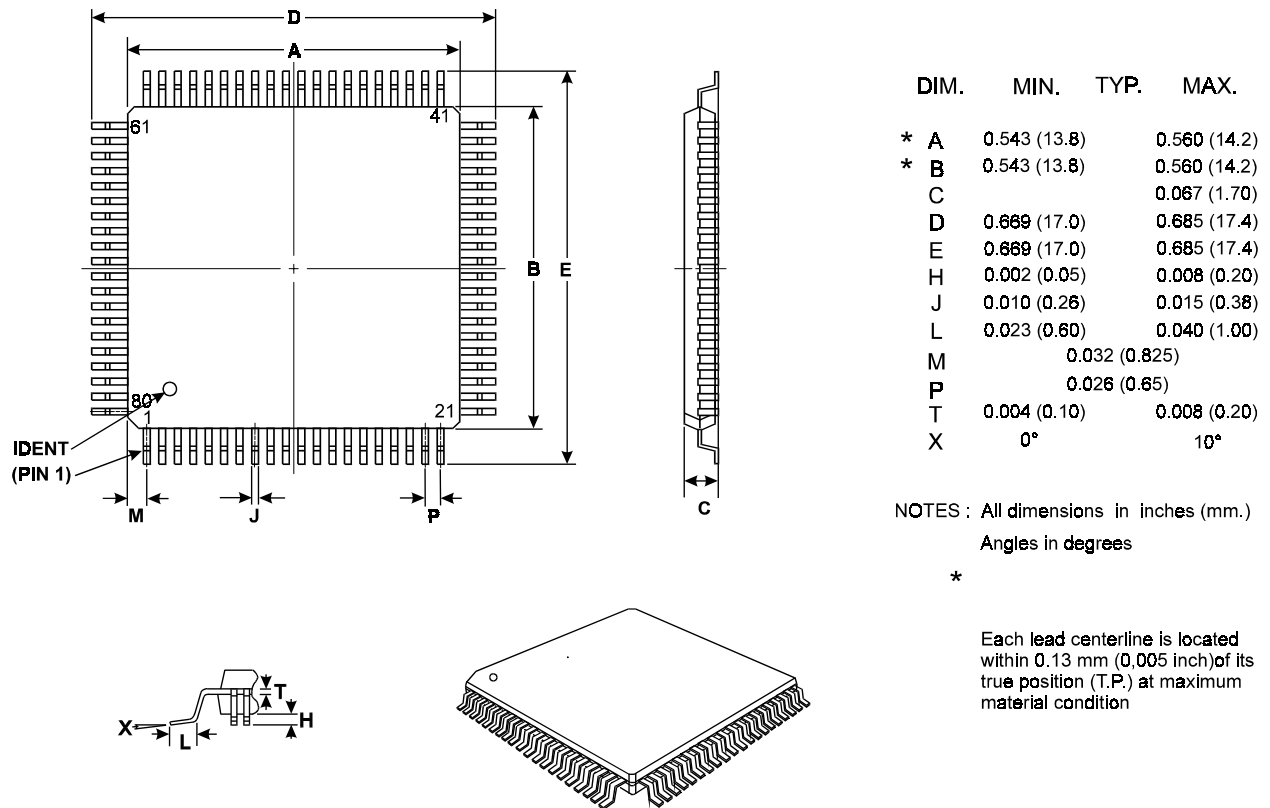

Figure 6: 80-pin QFP - Mechanical Outline: *Order as part no. CMX218S1*