



## General Description

The DSC1103 & DSC1123 series of high performance oscillators utilizes a proven silicon MEMS technology to provide excellent jitter and stability over a wide range of supply voltages and temperatures. By eliminating the need for quartz or SAW technology, MEMS oscillators significantly enhance reliability and accelerate product development, while meeting stringent clock performance criteria for a variety of communications, storage, and networking applications.

DSC1103 has a standby feature allowing it to completely power-down when EN pin is pulled low; whereas for DSC1123, only the outputs are disabled when EN is low. Both oscillators are available in industry standard packages, including the small 3.2x2.5 mm<sup>2</sup>, and are "drop-in" replacements for standard 6-pin LVDS quartz crystal oscillators.

## Block Diagram

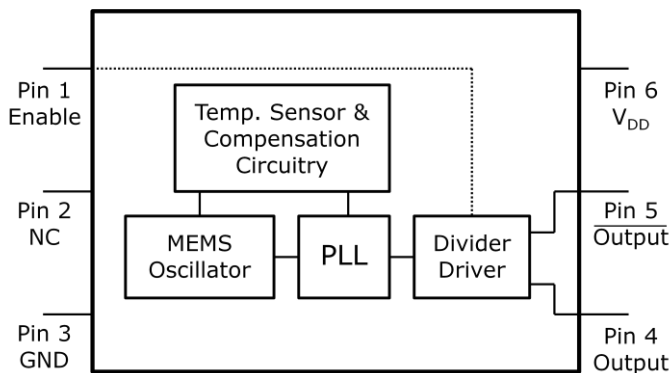

## Output Enable Modes

EN Pin	DSC1103	DSC1123
High	Outputs Active	Outputs Active
NC	Outputs Active	Outputs Active
Low	Standby	Outputs Disabled

## Features

- **Low RMS Phase Jitter: <1 ps (typ)**
- **High Stability: ±10, ±25, ±50 ppm**
- **Wide Temperature Range**
  - Industrial: -40° to 85° C
  - Ext. commercial: -20° to 70° C
- **High Supply Noise Rejection: -50 dBc**
- **Short Lead Time: 2 Weeks**
- **Wide Freq. Range: 2.3 to 460 MHz**
- **Small Industry Standard Footprints**
  - 2.5x2.0, 3.2x2.5, 5.0x3.2, & 7.0x5.0 mm
- **Excellent Shock & Vibration Immunity**
  - Qualified to MIL-STD-883
- **High Reliability**
  - 20x better MTF than quartz oscillators
- **Low Current Consumption**
- **Supply Range of 2.25 to 3.6 V**
- **Standby & Output Enable Function**
- **Lead Free & RoHS Compliant**
- **LVPECL & HCSL Versions Available**

## Applications

- **Storage Area Networks**
  - SATA, SAS, Fibre Channel
- **Passive Optical Networks**
  - EPON, 10G-EPON, GPON, 10G-PON
- **Ethernet**
  - 1G, 10GBASE-T/KR/LR/SR, and FCoE
- **HD/SD/SDI Video & Surveillance**
- **PCI Express: Gen 1 & Gen 2**
- **DisplayPort**

## Absolute Maximum Ratings

Item	Min	Max	Unit	Condition
Supply Voltage	-0.3	+4.0	V	
Input Voltage	-0.3	$V_{DD}+0.3$	V	
Junction Temp	-	+150	°C	
Storage Temp	-55	+150	°C	
Soldering Temp	-	+260	°C	40sec max.
ESD	-		V	
HBM		4000		
MM		400		
CDM		1500		

## Ordering Code

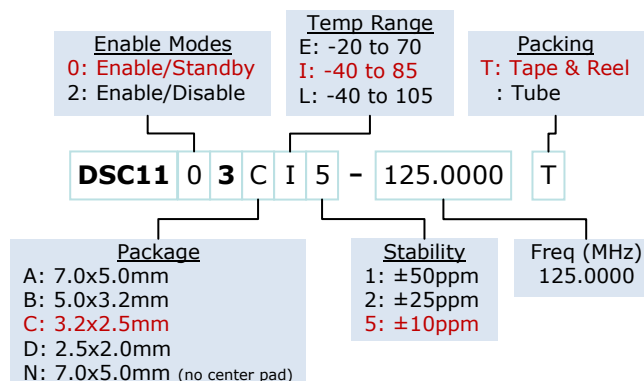

Note: 1000+ years of data retention on internal memory

## Specifications

Parameter		Condition	Min.	Typ.	Max.	Unit
Supply Voltage <sup>1</sup>	$V_{DD}$		2.25		3.6	V
Supply Current	$I_{DD}$	EN pin low – outputs are disabled DSC1103 DSC1123		20	0.095 22	mA
Frequency Stability	$\Delta f$	Includes frequency variations due to initial tolerance, temp. and power supply voltage			±10 ±25 ±50	ppm
Aging	$\Delta f$	1 year @25°C			±5	ppm
Startup Time <sup>2</sup>	$t_{SU}$	T=25°C			5	ms
Input Logic Levels Input logic high Input logic low	$V_{IH}$ $V_{IL}$		0.75x $V_{DD}$ -		- 0.25x $V_{DD}$	V
Output Disable Time <sup>3</sup>	$t_{DA}$				5	ns
Output Enable Time	$t_{EN}$	DSC1103 DSC1123			5 20	ms ns
Enable Pull-Up Resistor <sup>4</sup>		Pull-up resistor exist		40		k $\Omega$
<b>LVDS Outputs</b>						
Supply Current	$I_{DD}$	Output Enabled, $R_L=100\Omega$		29	32	mA
Output offset Voltage	$V_{OS}$	R=100 $\Omega$ Differential	1.125		1.4	V
Delta Offset Voltage	$\Delta V_{OS}$				50	mV
Pk to Pk Output Swing	$V_{PP}$	Single-Ended		350		mV
Output Transition time <sup>3</sup> Rise Time Fall Time	$t_R$ $t_F$	20% to 80% $R_L=50\Omega$ , $C_L=2pF$		200		ps
Frequency	$f_0$	Single Frequency	2.3		460	MHz
Output Duty Cycle	SYM	Differential	48		52	%
Period Jitter	$J_{PER}$			2.5		ps <sub>RMS</sub>
Integrated Phase Noise	$J_{PH}$	200kHz to 20MHz @156.25MHz 100kHz to 20MHz @156.25MHz 12kHz to 20MHz @156.25MHz		0.28 0.4 1.7	2	ps <sub>RMS</sub>

Notes:

- Pin 6  $V_{DD}$  should be filtered with 0.1 $\mu$ f capacitor.
- $t_{SU}$  is time to 100ppm of output frequency after  $V_{DD}$  is applied and outputs are enabled.
- Output Waveform and Test Circuit figures below define the parameters.
- Output is enabled if pad is floated or not connected.

**Nominal Performance Parameters** (Unless specified otherwise:  $T=25^{\circ}C$ ,  $V_{DD}=3.3V$ )

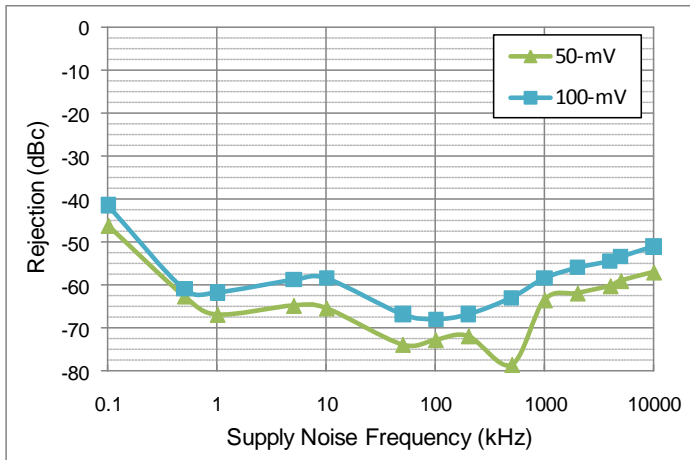

Power supply rejection ratio

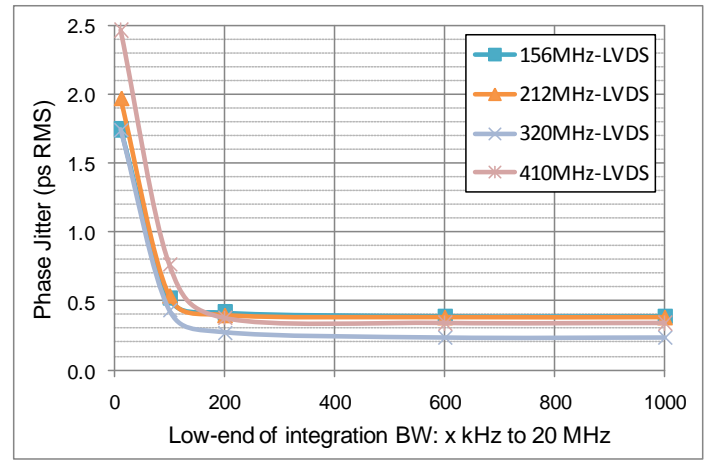

Phase jitter (integrated phase noise)

**Output Waveform**

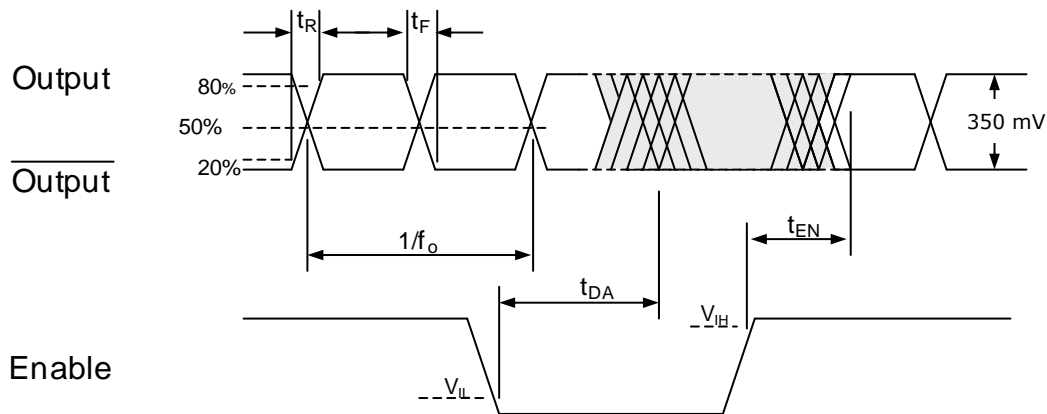

**Typical Termination Scheme**

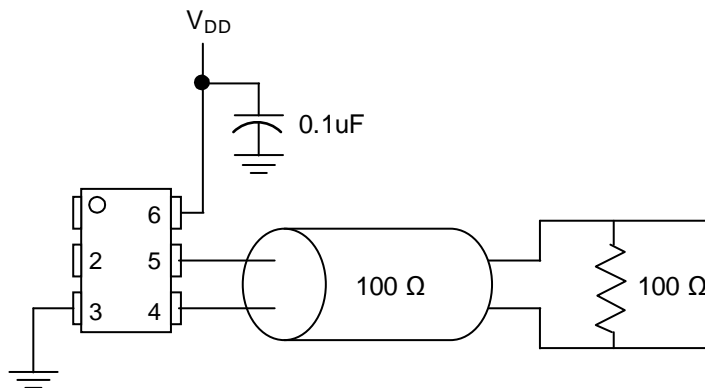

### Test Circuit

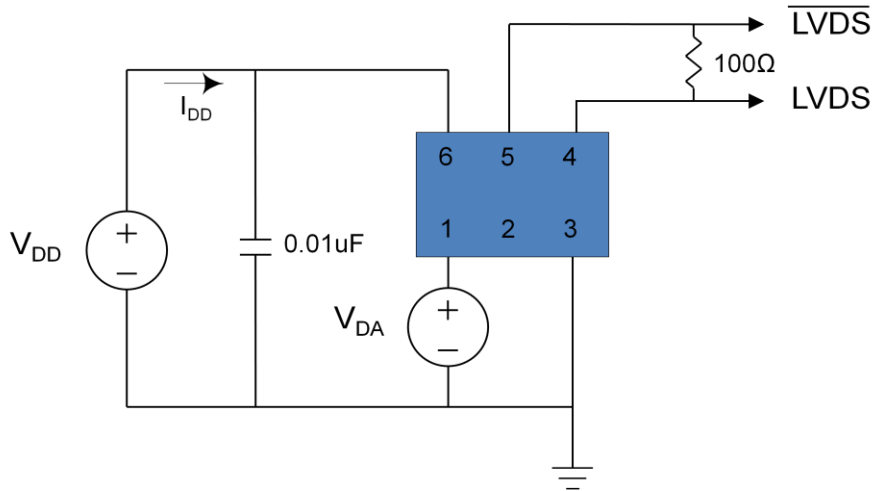

### Solder Reflow Profile

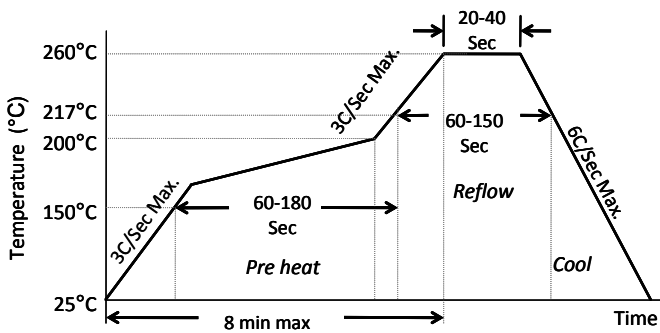

MSL 1 @ 260°C refer to JSTD-020C	
Ramp-Up Rate (200°C to Peak Temp)	3°C/Sec Max.
Preheat Time 150°C to 200°C	60-180 Sec
Time maintained above 217°C	60-150 Sec
Peak Temperature	255-260°C
Time within 5°C of actual Peak	20-40 Sec
Ramp-Down Rate	6°C/Sec Max.
Time 25°C to Peak Temperature	8 min Max.

## Package Dimensions

### 7.0 x 5.0 mm Plastic Package

#### EXTERNAL DIMENSIONS

Units: mm [ inches]

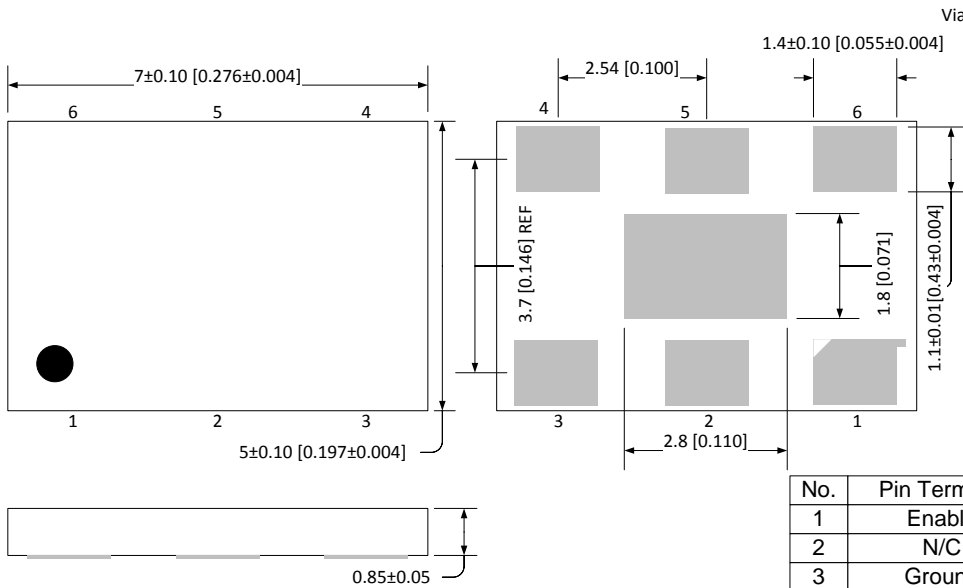

#### RECOMMENDED SOLDER PAD LAYOUT

Units: mm [ inches]

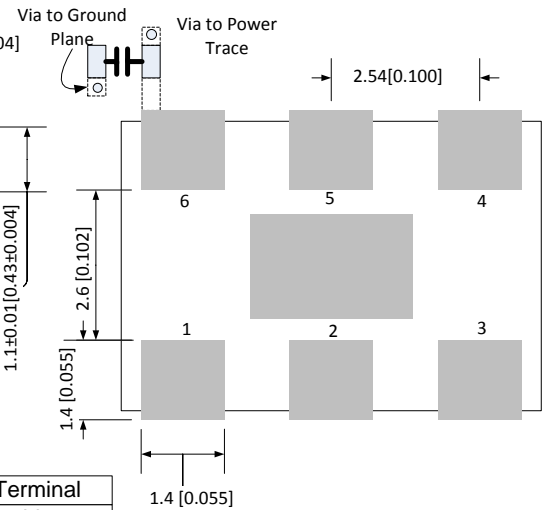

No.	Pin Terminal
1	Enable
2	N/C
3	Ground
4	OUT
5	OUT-
6	VDD
PAD	TIE TO GND

### 5.0 x 3.2 mm Plastic Package

#### EXTERNAL DIMENSIONS

Units: mm [ inches]

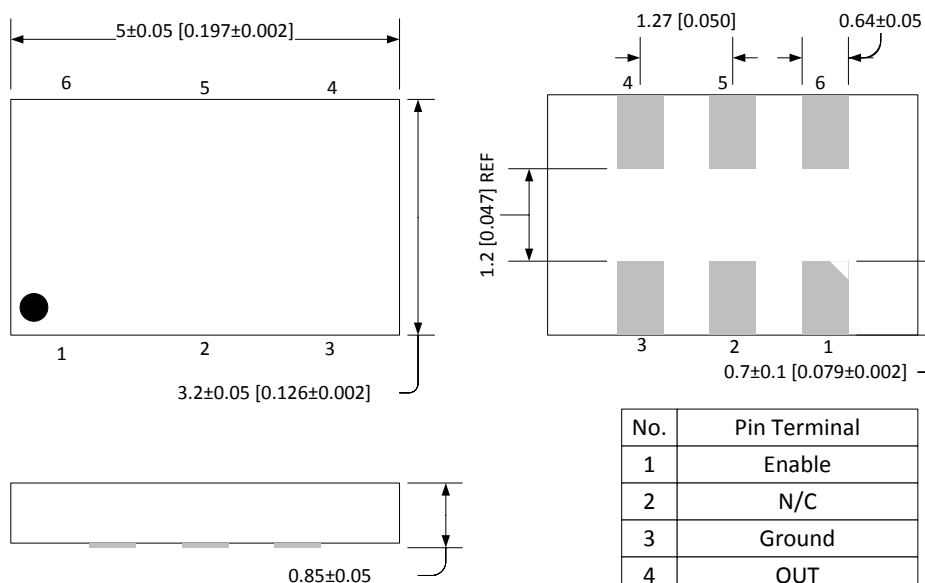

#### RECOMMENDED SOLDER PAD LAYOUT

Units: mm [ inches]

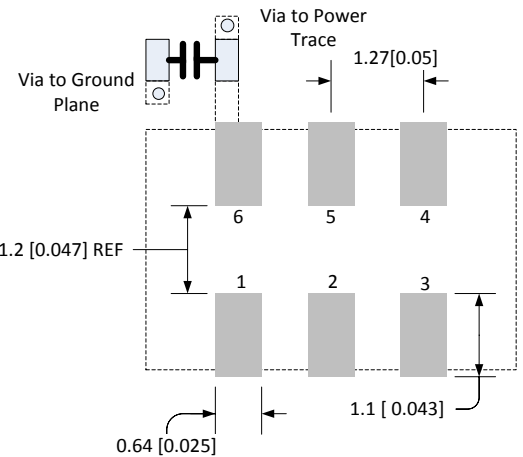

No.	Pin Terminal
1	Enable
2	N/C
3	Ground
4	OUT
5	OUT-
6	VDD

### 3.2 x 2.5 mm Plastic Package

#### EXTERNAL DIMENSIONS

Units: mm [ inches]

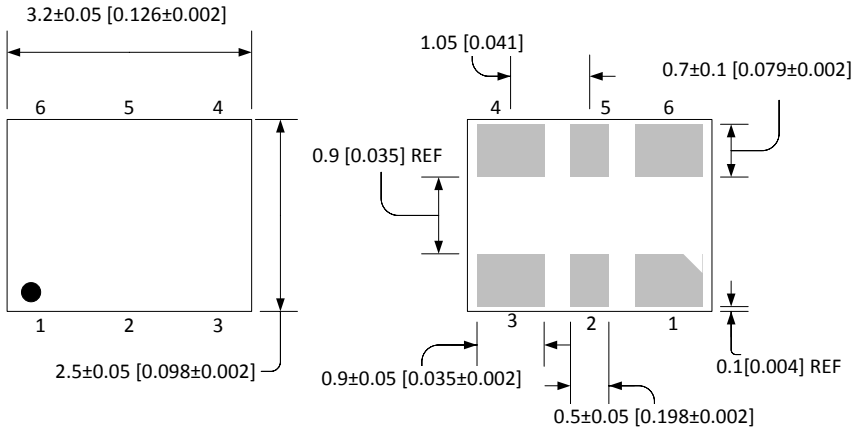

#### RECOMMENDED SOLDER PAD LAYOUT

Units: mm [ inches]

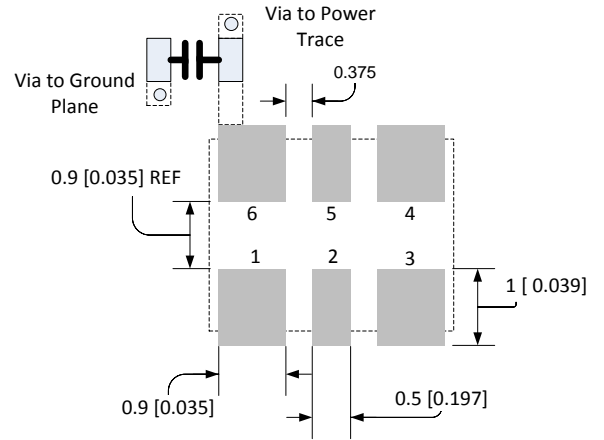

No.	Pin Terminal
1	Enable
2	N/C
3	Ground
4	OUT
5	OUT-
6	VDD

### 2.5 x 2.0 mm Plastic Package

#### EXTERNAL DIMENSIONS

Units: mm [ inches]

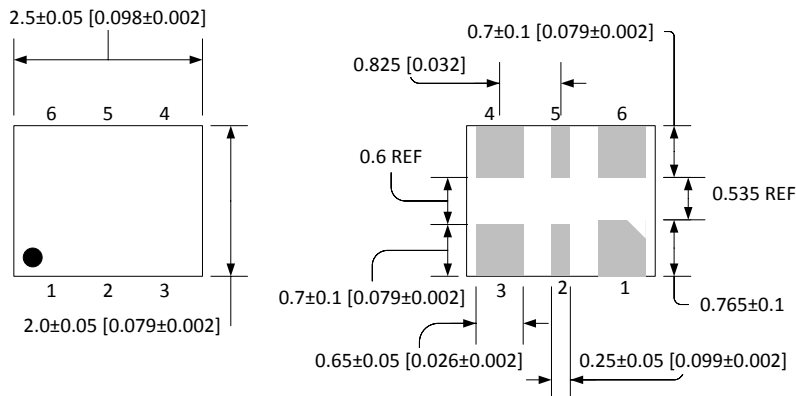

#### RECOMMENDED SOLDER PAD LAYOUT

Units: mm [ inches]

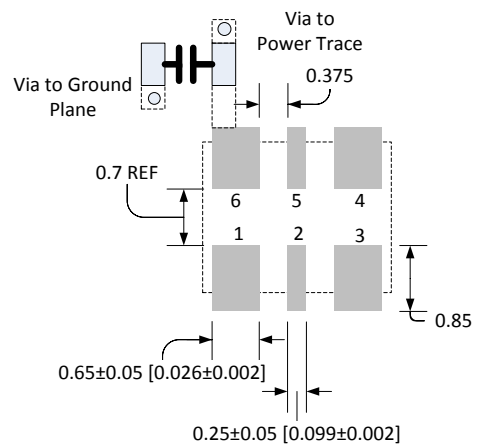

No.	Pin Terminal
1	Enable
2	N/C
3	Ground
4	OUT
5	OUT-
6	VDD

## 7.0 x 5.0 mm Plastic Package

### EXTERNAL DIMENSIONS

Units: mm [ inches]

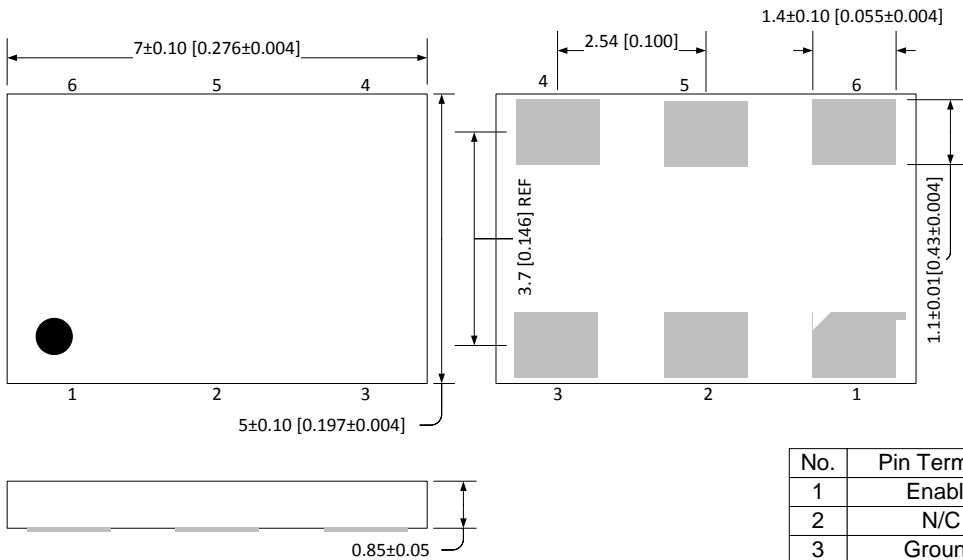

### RECOMMENDED SOLDER PAD LAYOUT

Units: mm [ inches]

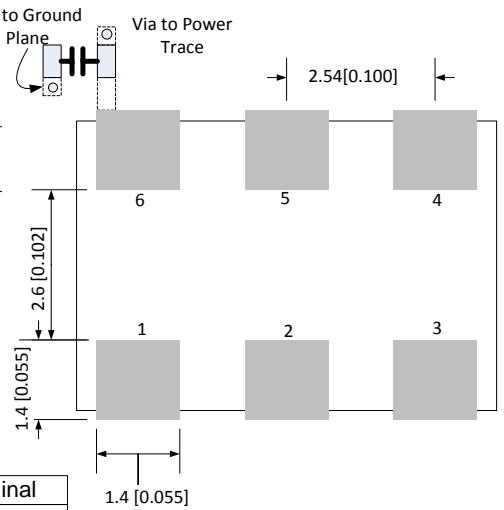

No.	Pin Terminal
1	Enable
2	N/C
3	Ground
4	OUT
5	OUT-
6	VDD

### **Disclaimer:**

Discera makes no warranty of any kind, express or implied, with regard to this material, including, but not limited to, the implied warranties of merchantability and fitness for a particular purpose. Discera reserves the right to make changes without further notice to materials described herein. Discera does not assume any liability arising from the application or use of any product or circuit described herein. Discera does not authorize its products for use as critical components in life-support systems where a malfunction or failure may reasonably be expected to result in significant injury to the user. The inclusion of Discera's product in a life-support systems application implies that the manufacturer assumes all risk of such use and in doing so indemnifies Discera against all charges.