



# AN11012

## Using the TEA1703 to reduce standby power

Rev. 1 — 30 March 2011

Application note

### Document information

Info	Content
<b>Keywords</b>	SMPS, TEA1703, TEA1738, TEA1753, standby power
<b>Abstract</b>	TEA1703 is a low power standby controller IC intended for use in SMPS applications that require an extremely low no-load standby power. The TEA1703 includes detection circuitry for output voltage, output power and also switching detection circuitry. The TEA1703 integrates a switched mode optocoupler driver which makes it possible to drive an optocoupler with a high peak current, while keeping the required power low. (NXP Semiconductors patent)



## Revision history

Rev	Date	Description
v.1	20110330	first issue

## Contact information

For more information, please visit: <http://www.nxp.com>

For sales office addresses, please send an email to: [salesaddresses@nxp.com](mailto:salesaddresses@nxp.com)

## 1. Introduction

---

The number of electronic products used today in private homes and offices is constantly increasing. Most products, such as: audio equipment, TVs, digital cable receivers, DVD/Blu ray recorders, computers, printers, etc. consume a considerable amounts of electrical power while on standby (when they are not in use but are still connected to the mains supply). This not only is a waste of energy and money but also has a large impact on the environment. Today, many products required to run in Standby mode have to comply with requirements on energy consumption like the Energy Star 2.0 APS requirements.

The TEA1703 is a low power standby controller IC intended to be used in SMPS applications that require an extreme low no-load standby power. The TEA1703 includes detection circuitry for output voltage, output power and also switching detection circuitry. The TEA1703 integrates a switched mode optocoupler driver, which makes it possible to drive an optocoupler with a high peak current, while keeping the required power low. (NXP Semiconductors patent). using the TEA1703, the standby power consumption of a SMPS is reduced to 30 mW or less.

**Remark:** Unless otherwise stated all values given in this application note are typical values.

## 2. Scope and set-up of this application note

---

### 2.1 Scope

This application note describes the functionality of the TEA1703 standby controller and the operation in combination with the TEA1738 and TEA1753 SMPS controllers. Detailed application information is given on interfacing and performance optimization.

### 2.2 General setup of the application note

The setup of this document is made in such a way, that a section or paragraph on a selected subject can be read as a stand-alone explanation with a minimum of cross references to other document parts or the data sheet.

### 2.3 Related documents and tools

This application note gives no in depth application information on the TEA1738 or TEA1753 SMPS controller. Application notes, data sheets, user manuals and design tools can be found on the product pages for the TEA1703, TEA1738 and TEA1753 at <http://www.nxp.com>.

## 3. TEA1703 features

---

- SMPS standby controller IC enabling very low power standby operation
- Large input voltage range from 5 V up to 30 V
- Very low supply current of 30  $\mu$ A
- Switched mode optocoupler driver output (NXP Semiconductors patent)
- Ease of application

## 4. Pin description

Table 1. Pin description

Symbol	Pin	Description
VCC	1	supply voltage; the supply voltage ranges from 5 V to 30 V. The supply current is 30 $\mu$ A
GND	2	ground connection
OPTO	3	optocoupler driver; open-drain output with integrated diode to pin VCC. A coil in series with the optocoupler is used to achieve a high current transfer ratio. Alternatively, a resistor instead of a coil can be used.
n.c.	4, 5	not connected
SWDET	6	<p>switch detect input; when the SMPS is not switching and the input current is below the <math>I_{th(SWDET)}</math> threshold of 1.2 <math>\mu</math>A, this pin disables the TEA1703.</p> <p>The SWDET input can be used to prevent a reset of the latch protection via the VINSENSE of the SMPS. This is the case with the TEA1753.</p> <p>The SWDET pin can be connected to VCC via a resistor when the functionality is not necessary. The input is clamped at 1 <math>V_d</math>, 0.74 V at 1.2 <math>\mu</math>A.</p>
PSENSE	7	power sense input; the optocoupler pulses are enabled when the voltage on PSENSE drops below 0.5 V. This level is reached at a certain output power level and can be adjusted using an external filtering network connected to pin PSENSE. Pin PSENSE has a hysteresis of 15 mV. The input impedance is approximately 100 $M\Omega$ .
VSENSE	8	<p>voltage sense input; the optocoupler pulses are disabled when VSENSE drops below 1.22 V. This level is reached when the output voltage drops to a certain level. This level can be adjusted using a resistor divider network from the converter output to pin VSENSE.</p> <p>In Standby mode, the output voltage varies between the nominal output voltage (i.e. the output voltage obtained during normal operation) and the minimum output voltage adjusted which can be as low as 5 V.</p> <p>Pin VSENSE has no hysteresis but below 1.22 V and the internal current source of 0.9 <math>\mu</math>A from VCC is switched off. The current provides a small hysteresis across the VSENSE resistor to ground. The input impedance (below 1.22 V) is approximately 100 <math>M\Omega</math>.</p>

### 5. Application diagram

Figure 1 shows the TEA1703 connections in a typical application.

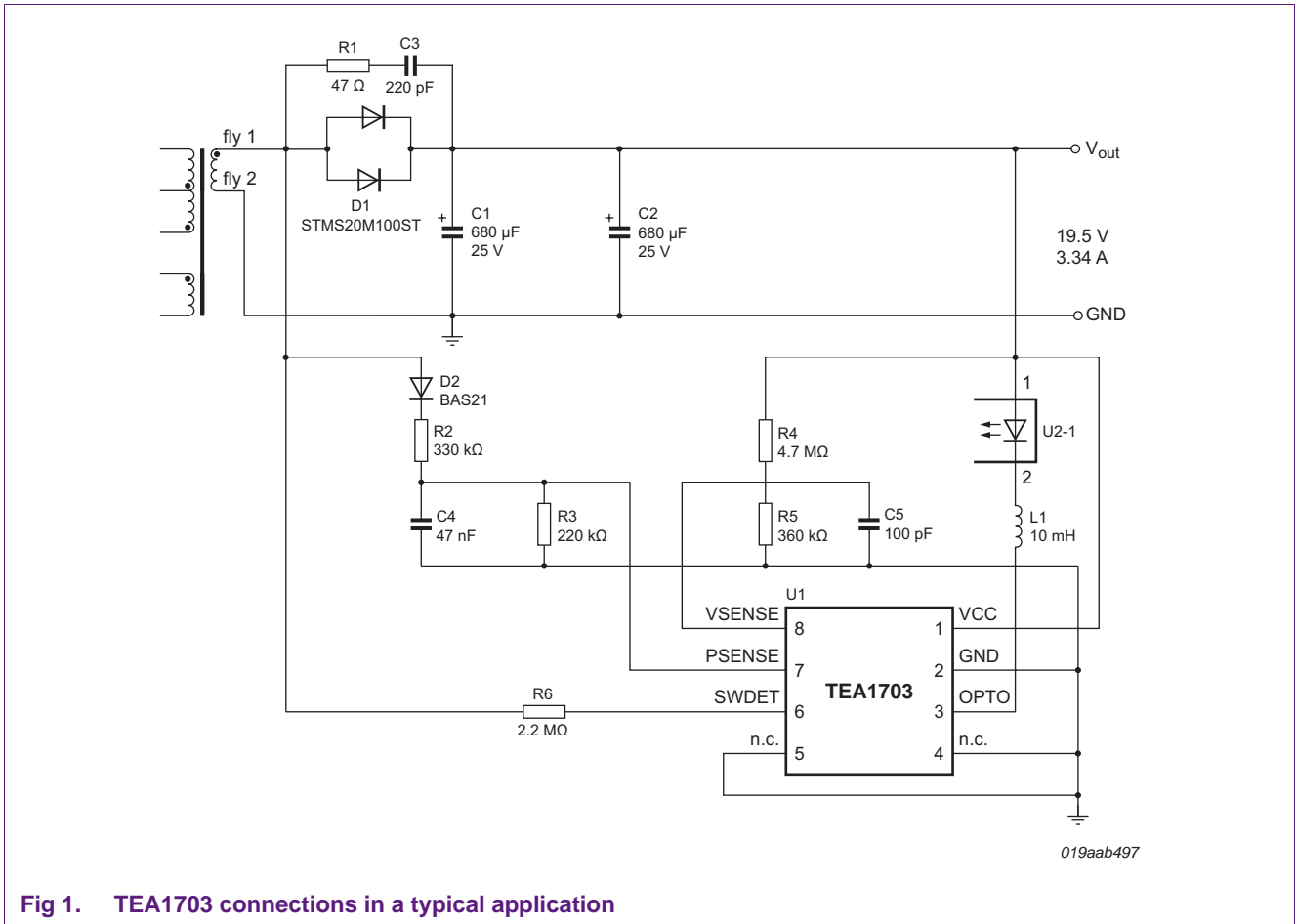

Fig 1. TEA1703 connections in a typical application

## 6. TEA1703 description and calculation

This section describes the TEA1703 functions and operation in a typical application.

### 6.1 General description

The TEA1703 is a standby controller IC that reduces the standby power of a switched mode power supply. Standby mode operation information is obtained by sensing the output voltage and the output power of the SMPS. The output voltage is measured at pin VSENSE of the TEA1703 via the resistor divider R4 and R5 as shown in [Figure 1](#). The output power is measured at the flyback winding of the transformer via D2 and a low-pass filter made by R2, R3 and C4 as shown in [Figure 1](#).

The principle of output power measuring is based on SMPS converters where the output power at low load increases with frequency, e.g. in a discontinuous conduction mode flyback converter which has a fixed primary peak current during low load operation.

The block diagram ([Figure 2](#)) shows the VSENSE and PSENSE inputs and the corresponding comparators. A SWDET input is added to disable Standby mode detection e.g. when a latched protection is active. When pins VSENSE, PSENSE and SWDET have the correct levels, the 28 kHz oscillator is enabled. The oscillator drives the MOSFET at the OPTO pin with an on-time of 1.4  $\mu$ S (4 % duty cycle). Pin OPTO drives the optocoupler via a coil and disables the SMPS.

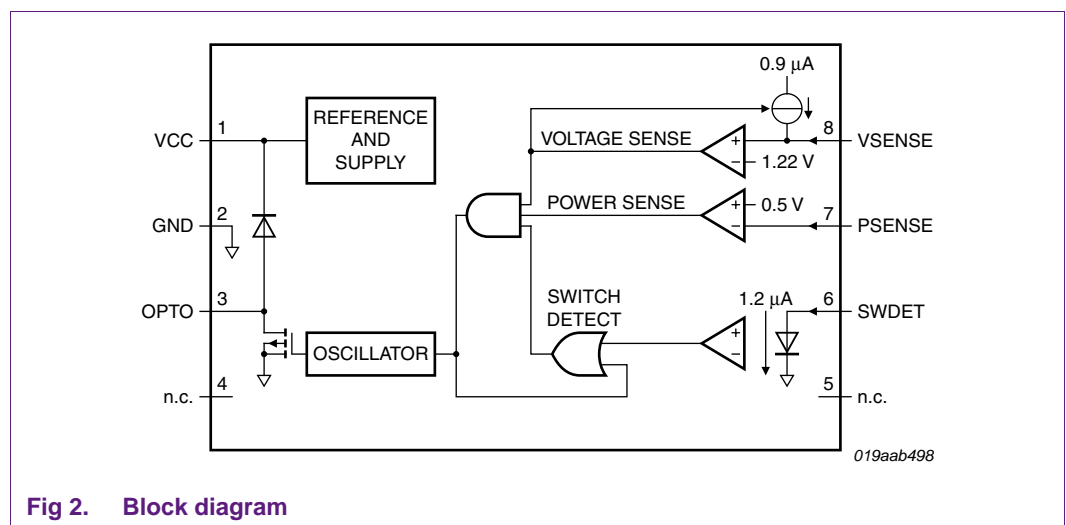
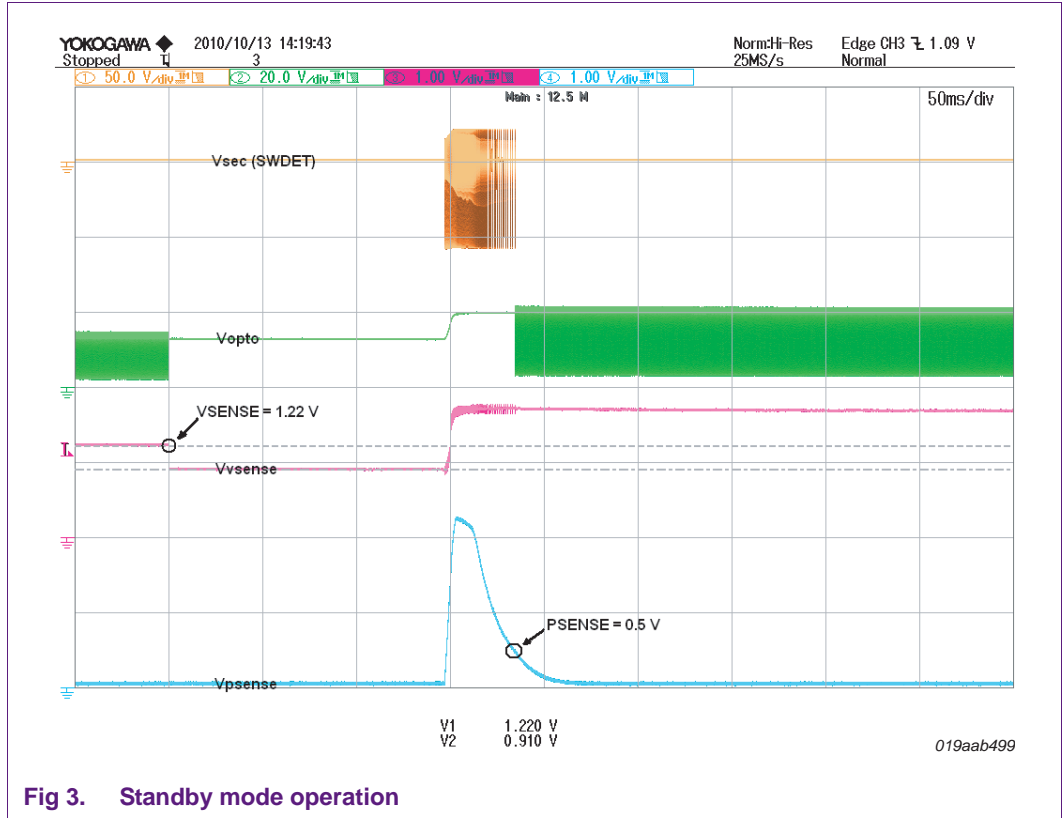

Fig 2. Block diagram

### 6.2 Standby mode operation

The Standby mode operation signals are shown in [Figure 3](#). In Standby mode the optocoupler pulses generated by the TEA1703 disable the SMPS and consequently the output voltage drops. When the voltage at pin VSENSE reaches 1.22 V, the 0.9  $\mu$ A current source is switched off and VSENSE drops below 1.22 V. The small hysteresis prevents fast on/off switching of the VSENSE comparator.

As the output of the VSENSE comparator is low, the optocoupler pulses are disabled and the SMPS can restart. When the output capacitors are charged and the voltage on PSENSE drops below 0.5 V, optocoupler pulses are generated again on the first SWDET pulse. In a typical application the SMPS restarts every couple of minutes. This considerably reduces the standby power consumption.



### 6.3 Normal operation

The transition to normal operation is shown in [Figure 4](#). When, during Standby mode operation, a load higher than the Standby mode power threshold is connected, the SMPS switches to normal operation. In the example of [Figure 4](#), a load slightly above the standby power threshold is connected. VSENSE drops faster than during Standby mode operation. When VSENSE reaches 1.22 V, the SMPS starts-up and remains active, as PSENSE does not drop below the 0.5 V PSENSE comparator level.

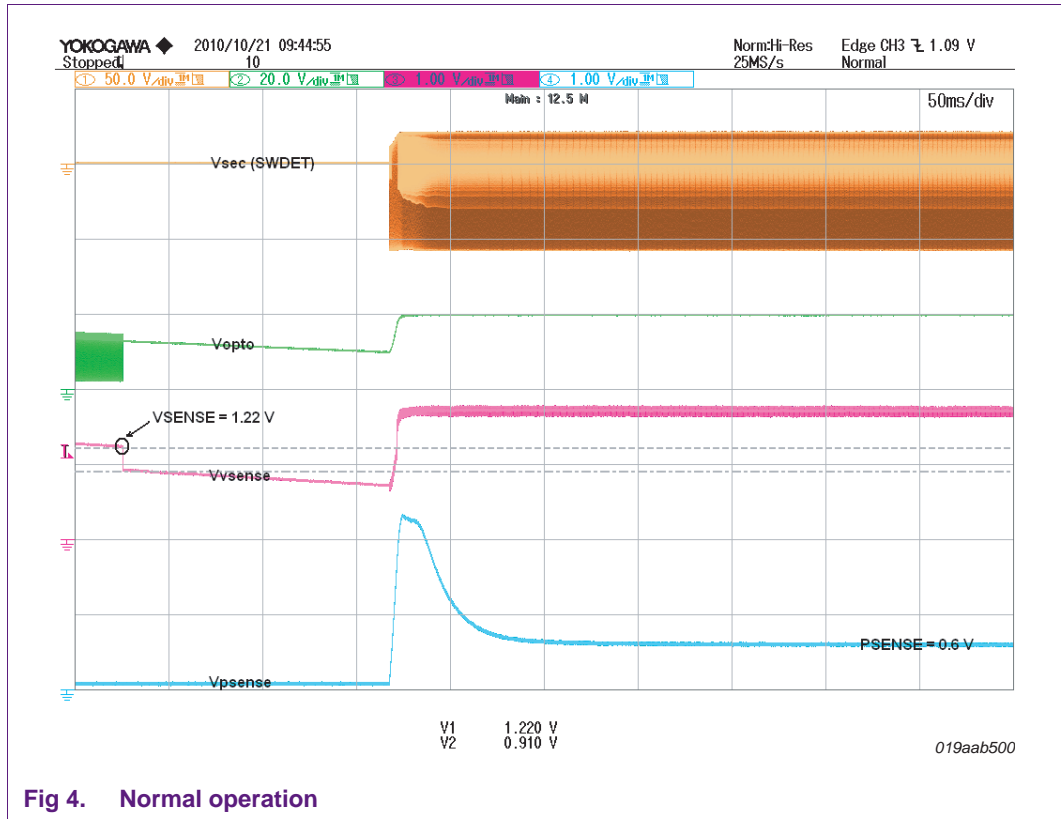

Fig 4. Normal operation

### 6.4 PSENSE

At pin PSENSE the actual output power of the SMPS is measured. Pin PSENSE should be connected to the secondary winding via a low pass filter (see [Figure 1](#)). The power level at pin PSENSE is compared to an internal reference of 0.5 V. Pin PSENSE disables the SMPS when the output power drops below a predefined level. The adjustment of the Standby mode power threshold depends on the power control behavior of the SMPS. The adjustment procedure for the TEA1738 is given in [Section 7.7.1](#).

The adjustment procedure for the TEA1753 is given in [Section 8.7.1](#).

### 6.5 VSENSE

At pin VSENSE the divided output voltage is compared to an internal reference voltage of 1.22 V. See the block diagram of [Figure 2](#). When the comparator level is reached, an internal current source of 0.9  $\mu$ A from VCC to pin VSENSE is switched off and VSENSE further drops below the comparator level. The hysteresis prevents fast on/off switching of the comparator. Pin VSENSE enables the SMPS when the output voltage drops below a predefined level. The adjustment procedure for the TEA1738 is given in [Section 7.7.2](#).

The adjustment procedure for the TEA1753 is given in [Section 8.7.2](#).



## 6.6 SWDET

A SMPS enters latched protection mode when an over voltage, over temperature or output short circuit situation occurs. If a protection is triggered, the SMPS stops switching and enters the off state. When the reason of the protection is removed, removing the mains resets the latched protection. A reset is triggered via the VCC supply (TEA1738) or via the VSENSE (TEA1753).

When pin SWDET is connected to the secondary transformer winding, as shown in [Figure 1](#), the SWDET input can be used to prevent a reset of the latch protection via the VSENSE of the SMPS. Without this precaution the latch protection of the TEA1753 is reset, as VSENSE is forced low in Standby mode.

When the latch protection is not reset via VSENSE but for instance via the VCC pin of the TEA1738, pin SWDET can be connected to the VCC of the TEA1703 via a 2.2 M $\Omega$  resistor. A VCC clamp (ZD2) as shown in [Figure 5](#) is required.

Pin SWDET is a current controlled input. A current above the  $I_{th(SWDET)}$  level of 1.2  $\mu$ A enables the Standby mode via the optocoupler when  $VSENSE \geq 1.22$  V and  $PSENSE \leq 0.5$  V. Place the current limiting resistor (R31 in [Figure 5](#), R50 in [Figure 13](#)) at pin SWDET.

A current below the  $I_{th(SWDET)}$  level of 1.2  $\mu$ A prevents switching from normal operation to the Standby mode.

## 6.7 Optocoupler

To minimize the Standby power consumption it is necessary to keep all currents in a SMPS application as low as possible. A high current transfer ratio type at low input currents is recommended for the optocoupler such as the B/C version of the LTV-356T or IS357.

To maintain the high current transfer ratio of the optocoupler, the optocoupler diode is driven with a high current and low duty cycle. The average current and consequently, the power consumption, is still low. The optocoupler drive is most effective when a coil in series is used. The coil is magnetized during the short on-time of 1.4  $\mu$ S and demagnetized during a longer time via the internal diode from the OPTO pin to the VCC pin. The use of a coil is much more efficient than the use of a series resistor where most of the energy is lost in the resistor.



7.1 General description and typical application

Figure 5 shows a typical application of the TEA1738 low cost SMPS controller and the TEA1703 Standby controller. During Standby operation, optocoupler U4 forces VINSENSE (pin 5 of the TEA1738) low via transistor Q3. The SMPS stops switching when the voltage on VINSENSE drops below 0.72 V.

7.2 Interfacing

To reduce standby power consumption, the AP431 reference (U4 in Figure 5) and the resistor divider R23 and R24 are switched off in standby by means of Q1. This reduces the standby power by 5 mW to 10 mW. The values of R26, R27 and C18 are not critical. Resistors R26 and R27 reduce the maximum gate voltage and C18 creates a switch off delay. See the switching signals in Figure 6. Until the output voltage reaches the minimum value, the power consumption is minimal.

Alternatively R26 and R27 can be increased to reduce the standby power consumption. This, however, reduces the accuracy of the output voltage because of the spread on the reference input current of the AP431.

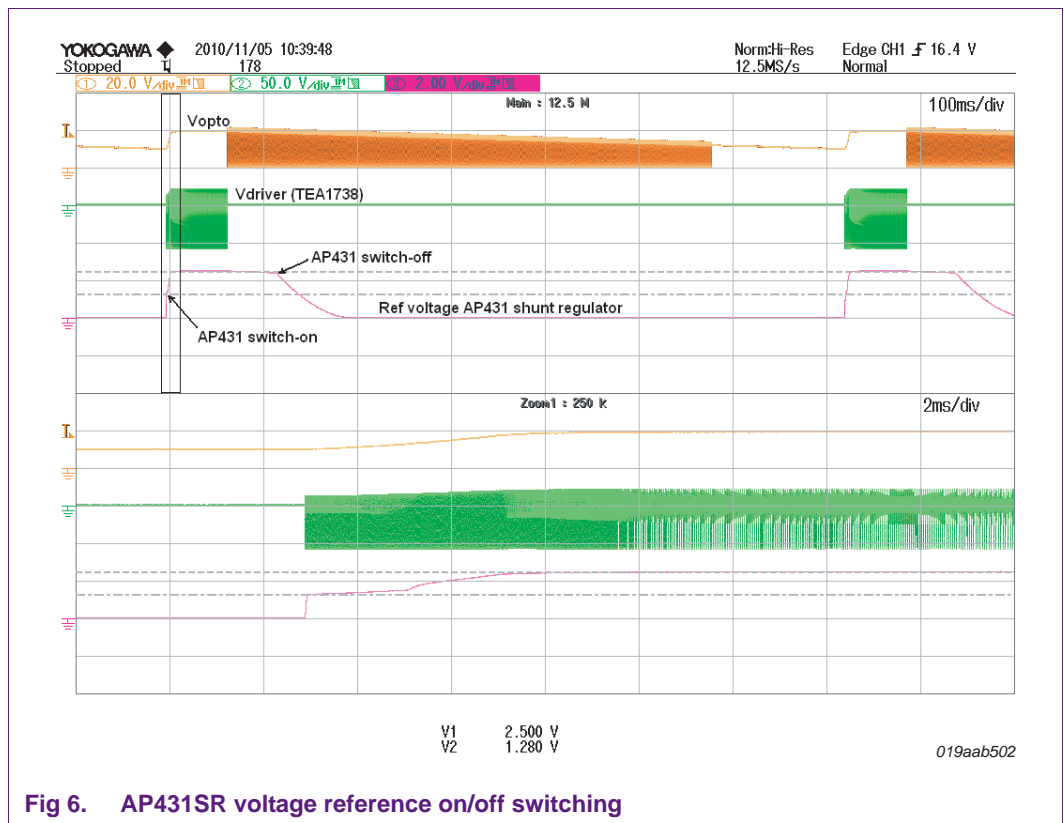

The standby information for the SMPS is obtained via optocoupler U4. The collector of the optocoupler is not connected directly to pin VINSENSE but via transistor Q3. This is necessary to comply with dark current requirements. Dark currents up to 10 μA can be managed.

**Remark:** Dark current is the current that can flow through the output phototransistor when it is turned off.

Zener diode ZD2 forms a VCC clamp at 18.5 V in Standby mode. This level is just below the TEA1738's minimum start-up voltage of 18.6 V. Without the Zener clamp the TEA1738 enters a repetitive restart mode where it consumes considerably more power. The Zener clamp furthermore facilitates a fast restart of the SMPS, as the VCC voltage only has to be charged from 18.5 V to 20.6 V.

During start-up VCC temporarily drops to 17 V and consequently the Zener current and base current for Q3 is insufficient to pull  $V_{VINSENSE}$  to ground. A bleeder resistor of 1 MΩ in parallel with the Zener diode ZD2 makes VCC drops down to 13 V possible.

### 7.3 General performance

The no-load standby power at 230 V (AC) of the SMPS shown in [Figure 5](#) is 39 mW. In Standby mode, the output voltage varies between 19.9 V and 12.6 V. The standby power threshold is 470 mW and the power-up time from standby to maximum load 160 ms.

### 7.4 Standby mode power consumption

The 39 mW Standby mode power consumption at 230 V (AC) is dissipated in:

- X-cap, bridge rectifier and elcap, 2.5 mW
- Start-up resistors R1 – R4, 32.5 mW
- VINSENSE resistors R9 to R12, 3.4 mW
- $V_{CC}$  of the TEA1738, less than 0.5 mW
- $V_{CC}$  of the TEA1703, less than 0.5 mW

The start-up resistors are responsible for a substantial part of the Standby mode power consumption. The resistors are chosen such that the start-up time at 115 V (AC) remains below 3 s. The Standby mode power consumption and start-up times for different resistor values are shown in [Table 2](#).

**Table 2. Standby mode power dissipation and start-up times for different start-up resistors**  
Capacitance is 4.7 μF + 100 nF.

R1 + R2 = R3+ R8	Standby power 230 V (AC)	Start-up time	
		90 V (AC)	115 V (AC)
1 MΩ	55 mW	2.54 s	1.65 s
1.2 MΩ	47 mW	3 s	2 s
1.5 MΩ	39 mW	4 s	2.6 s
1.8 MΩ	34 mW	5.2 s	3.2 s
2 MΩ	29 mW	6.7 s	4.2 s

A further reduction of the Standby mode power is possible when the startup resistors are replaced by a charge MOSFET with active X-cap discharge. See [Section 9](#), the VCC charge MOSFET with active X-cap discharge.

## 7.5 Power-up behavior

When a load is connected during Standby mode, the TEA1738 has to start-up before it can deliver full power. The start-up time (i.e. the time necessary to deliver full power) depends on the time to charge the VCC capacitor. The charge time depends on the mains voltage, the value of the VCC capacitance C11, and the value of the start-up resistors R1 to R4. To minimize the start-up time the VCC voltage in Standby mode is clamped at 18.5 V.

This considerably reduces the start-up time. Using the given component values and a load current of 3.3 A, the start-up time at 90 V (AC) is 858 ms. At 230 V (AC) it is 160 ms.

See the power-up behavior shown in [Figure 7a](#) and [Figure 7b](#).

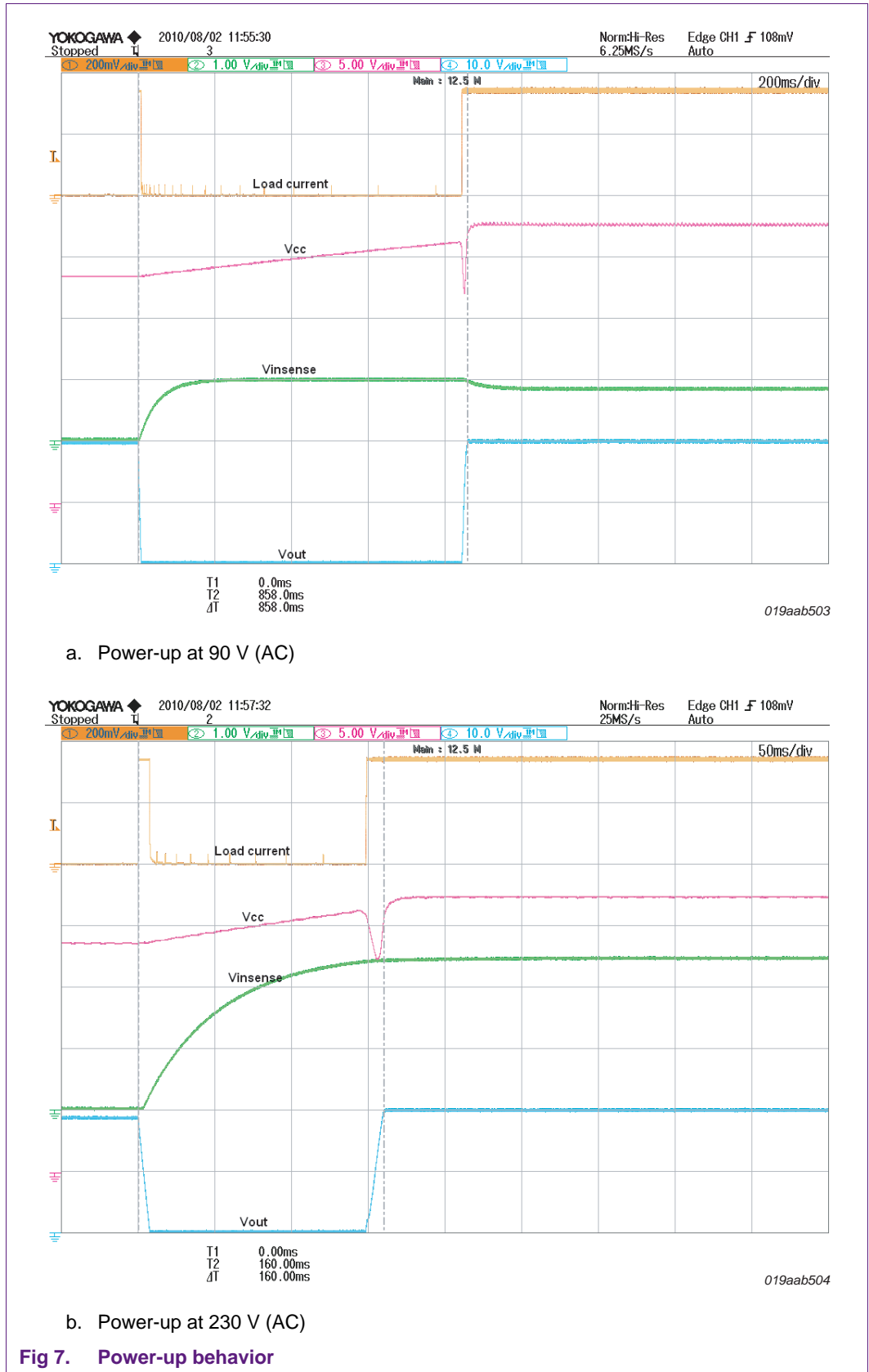

### 7.6 Power-down behavior

Figure 8 shows the power-down behavior. When the load is disconnected, or when the load drops below the Standby mode power threshold, the voltage at pin PSENSE drops below 0.5 V. On the first SWDET pulse optocoupler pulses are generated, VINSENSE is forced low and the SMPS is forced into Standby mode.

Using the TEA1738 the SWDET functionality is not necessary as the VCC clamp prevents a reset of the latch protection. Alternatively pin SWDET can be connected to pin VCC via a high-ohmic resistor of 2.2 MΩ.

**Remark:** The latched protection of the TEA1738 is reset when the voltage VCC drops below 5 V

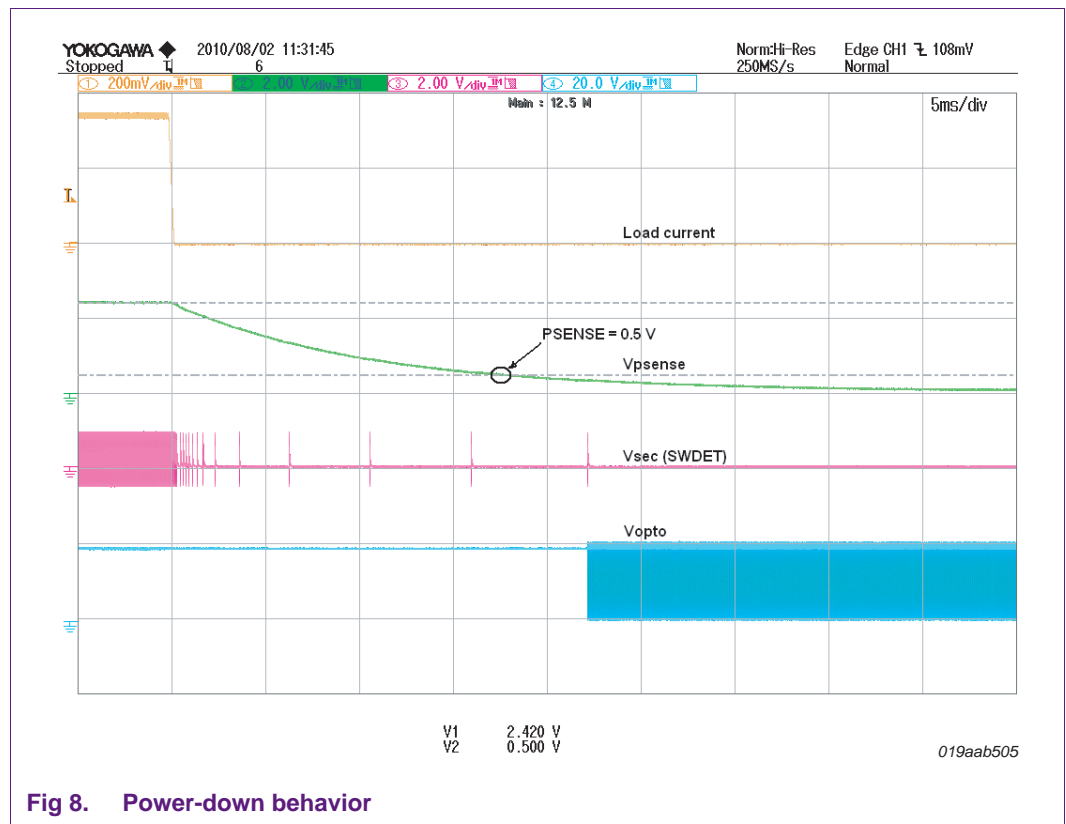

Fig 8. Power-down behavior

### 7.7 Adjustments

Using the component values shown in Figure 5, the power level to enter Standby mode is 470 mW and the minimum output voltage level at which the optocoupler is disabled 12.6 V. These levels can be adjusted separately. Preferably the power level is adjusted first.

### 7.7.1 Standby mode power threshold level adjustment

The power level to enter the Standby mode can be adjusted using the low-pass filter connected to pin PSENSE.

Before adjustment, the correct Standby mode power level should be chosen.

A good choice is a power level slightly lower than the minimum power level of the application during normal operation. For example, at a minimum power level of 300 mW, R30 should be  $\geq 430 \text{ k}\Omega$ . See the curves of [Figure 9](#). The slight difference between 115 V (AC) and 230 V (AC) is caused by the overshoot of the  $I_{\text{peak}}$  detector. The higher  $I_{\text{peak}}$  at 230 V (AC) results in a lower switching frequency and lower PSENSE voltage.

Capacitor C20 in parallel to R30 in [Figure 5](#) reduces the ripple at PSENSE. The ripple at PSENSE around the comparator level of 500 mV should be less than the hysteresis of 15 mV.

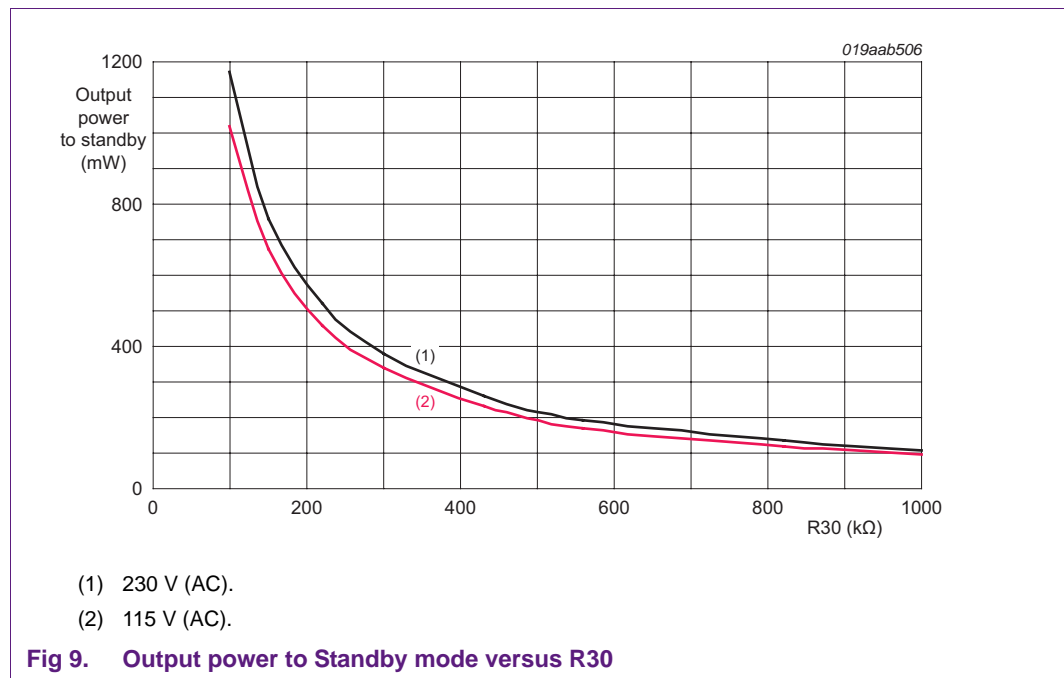

### 7.7.2 Minimum output voltage adjustment

In Standby mode, the output voltage varies between two levels. The maximum level is the output voltage of the SMPS during normal operation. The minimum level is the output voltage reached in Standby mode before the SMPS restarts. See [Figure 10](#) where the output voltage variation is shown in Standby mode for a 20 mA load at 115 V (AC) and 230 V (AC). At a higher load the SMPS switches to normal operation.



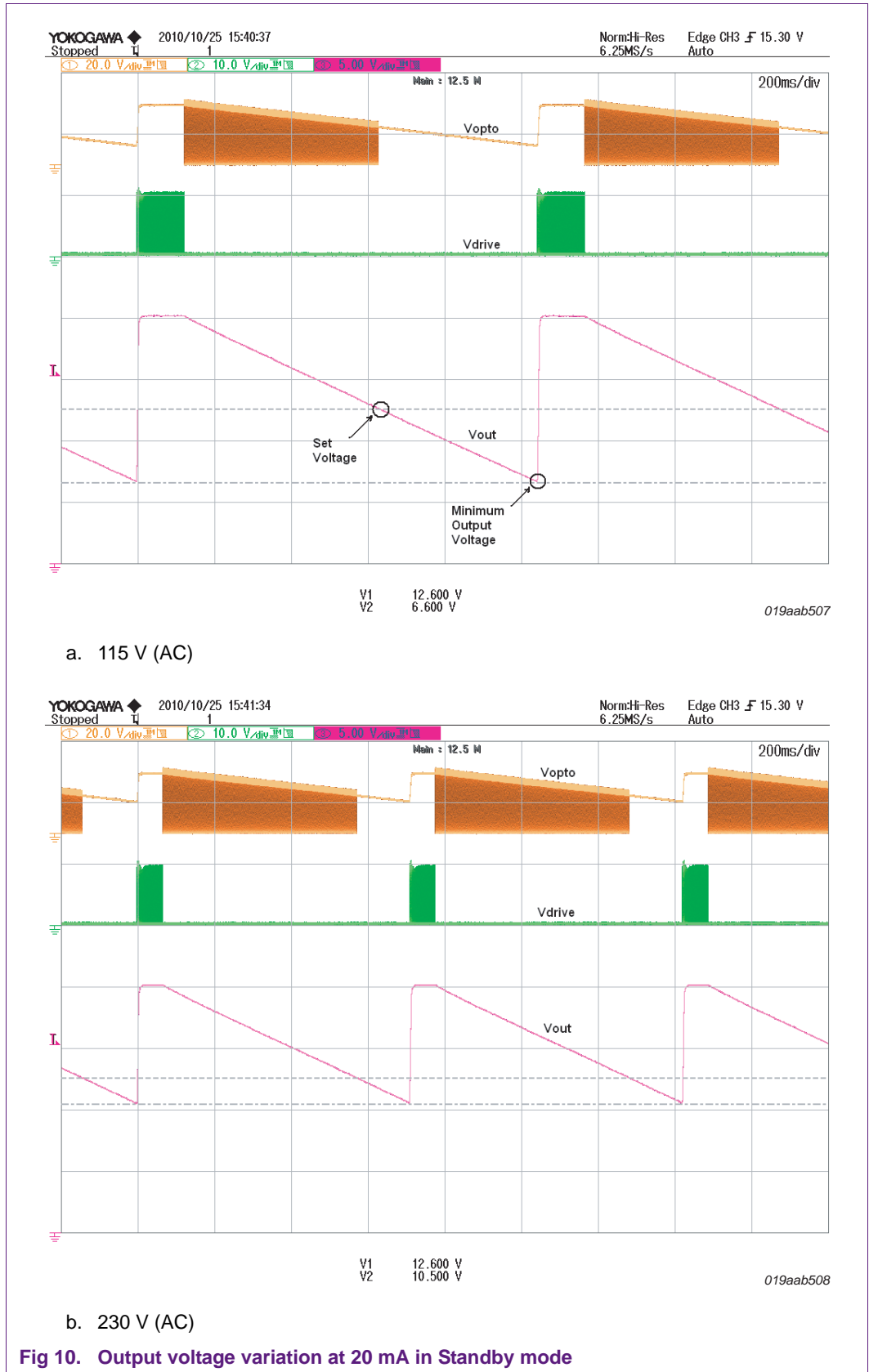

The minimum output voltage depends on the load in Standby mode. When the output load is zero the minimum output voltage is equal to the set voltage. The set voltage is the output voltage set with the resistor divider at pin VSENSE. See [Figure 5](#).

When the output is loaded in Standby mode, the output voltage decreases below the set voltage until the SMPS restarts. In that case the minimum output voltage is lower than the set voltage. When the application of [Figure 5](#) is loaded with 20 mA in Standby mode, the difference between the set voltage and minimum output voltage is 6 V at 115 V (AC). See [Figure 10a](#). At 230 V (AC), the difference is less and about 2.1 V. At 230 V (AC) the charge current for the VCC capacitor is higher and consequently the start-up time shorter.

**7.7.2.1 Adjustment procedure at standby no-load**

- Determine the minimum output voltage  $V_{min}$ . For minimum standby power the minimum output voltage should be as low as possible but above 5 V. At no load there is hardly any difference between  $V_{min}$  and the set voltage  $V_{set}$
- Resistor  $R33 = 1.22 / (((V_{min} - 1.22) / R32) + 1e^{-6})$ . Alternatively the value for R33 for can be found in [Figure 11](#). The curve is valid for  $R32 = 4.7\text{ M}\Omega$

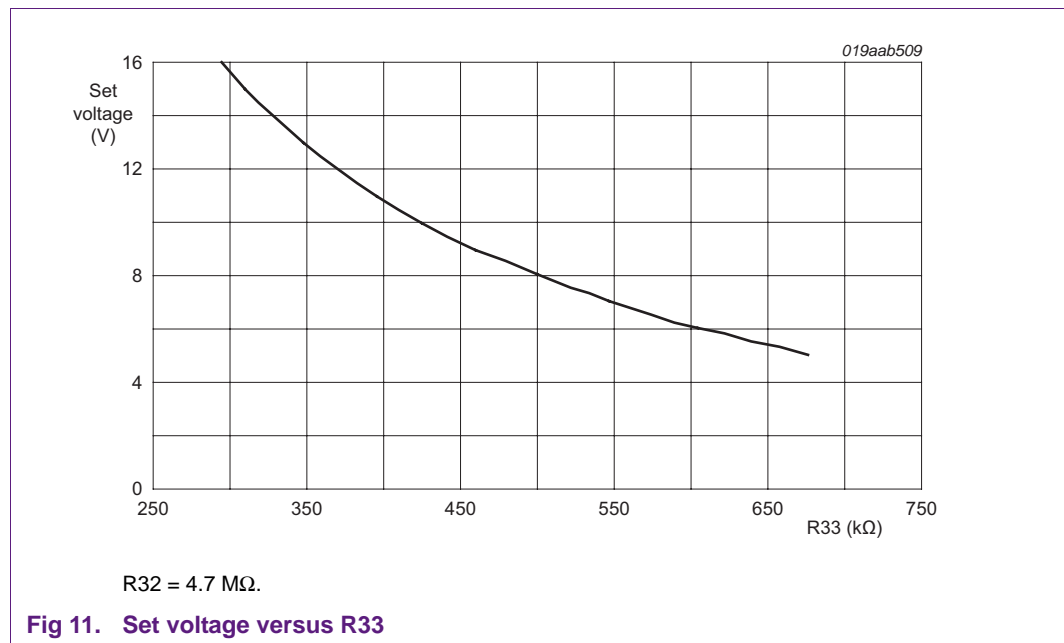

**Fig 11. Set voltage versus R33**

**7.7.2.2 Adjustment procedure at low standby loads**

At low loads up to the Standby mode power threshold level, the minimum output voltage is lower than the set voltage. See [Figure 10](#) for an output load of 20 mA. To guarantee a minimum output voltage is it necessary to adjust to a higher voltage (i.e. to the set voltage as shown in [Figure 11](#)). The adjustment procedure is as follows:

- Make  $R32 = 4.7\text{ M}\Omega$  and  $R33 = 360\text{ k}\Omega$ . Now the set voltage sufficiently high; 12.6 V
- Apply the minimum mains voltage, e.g. 115 V (AC)
- Apply the maximum Standby mode load. At this load level the SMPS should not enter normal operation. If not done already, it is important to first carry out the standby power threshold level adjustment as described in [Section 7.7.1](#)
- Measure  $V_{OPTO}$ ,  $V_{DRIVER}$  and  $V_{OUT}$  using an oscilloscope as shown in [Figure 10](#)

- Determine the new set voltage when the minimum output voltage is not appropriate. For minimum standby power the minimum output voltage should be as low as possible but above 5 V. The difference, however, is slight
- Resistor  $R33 = 1.22 / (((V_{\text{set}} - 1.22) / R32) + 1e^{-6})$ . Alternatively, the value for R33 for can be found in [Figure 11](#). The curve is valid for  $R32 = 4.7 \text{ M}\Omega$

### 7.7.3 Choosing the right coil

When the set voltage is low, the voltage across the coil and the current through the optocoupler might become too low to force  $V_{\text{VINSENSE}}$  low and to disable the SMPS. In this situation a lower self-inductance is an option.

Be careful not to exceed the maximum peak current of the optocoupler and keep in mind that a large peak current effects the life cycle of the optocoupler and the standby power consumption. Peak currents above 10 mA already have impact on the life cycle of the optocoupler. The coil of 10 mH used in [Figure 5](#) is a compromise between the maximum peak current of 2.5 mA and the minimum drive current of 0.655 mA for the optocoupler. The coil current and optocoupler pulses for the minimum and maximum output voltage of 5 V and 20 V are shown in [Figure 12](#).

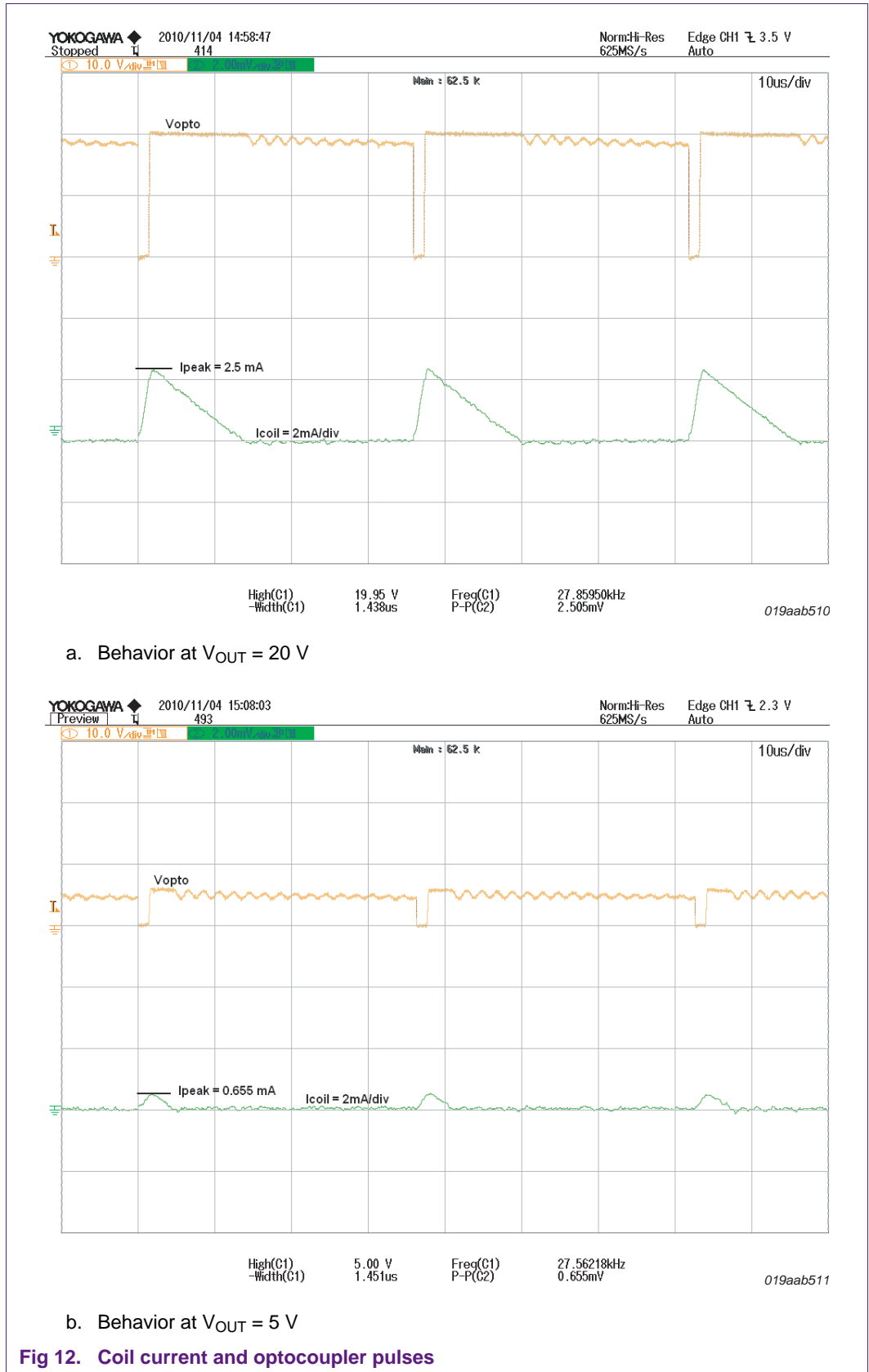

The peak value of the coil current is calculated using:

$$I_{peak} = \frac{10 \times (V_{CC} - V_f) \times \delta}{f_{osc} \times L} \quad (1)$$

where:

$I_{peak}$  (mA) = peak coil current

$V_{CC}$  (V) = supply voltage of the TEA1703; equal to  $V_{OUT}$

$V_f$  (V) = forward voltage of the optocoupler; 1.2 V

$\delta$  (%) = duty cycle of the optocoupler pulse; 4 %

$f_{osc}$  (Hz) = oscillator frequency, 28 kHz

$L$  (H) = inductance of coil L2 in [Figure 5](#), 10 mH

## 8. Typical application TEA1703 with the TEA1753

See [Figure 13 on page 22](#) and [Figure 14 on page 23](#) for a detailed overview of the typical application.

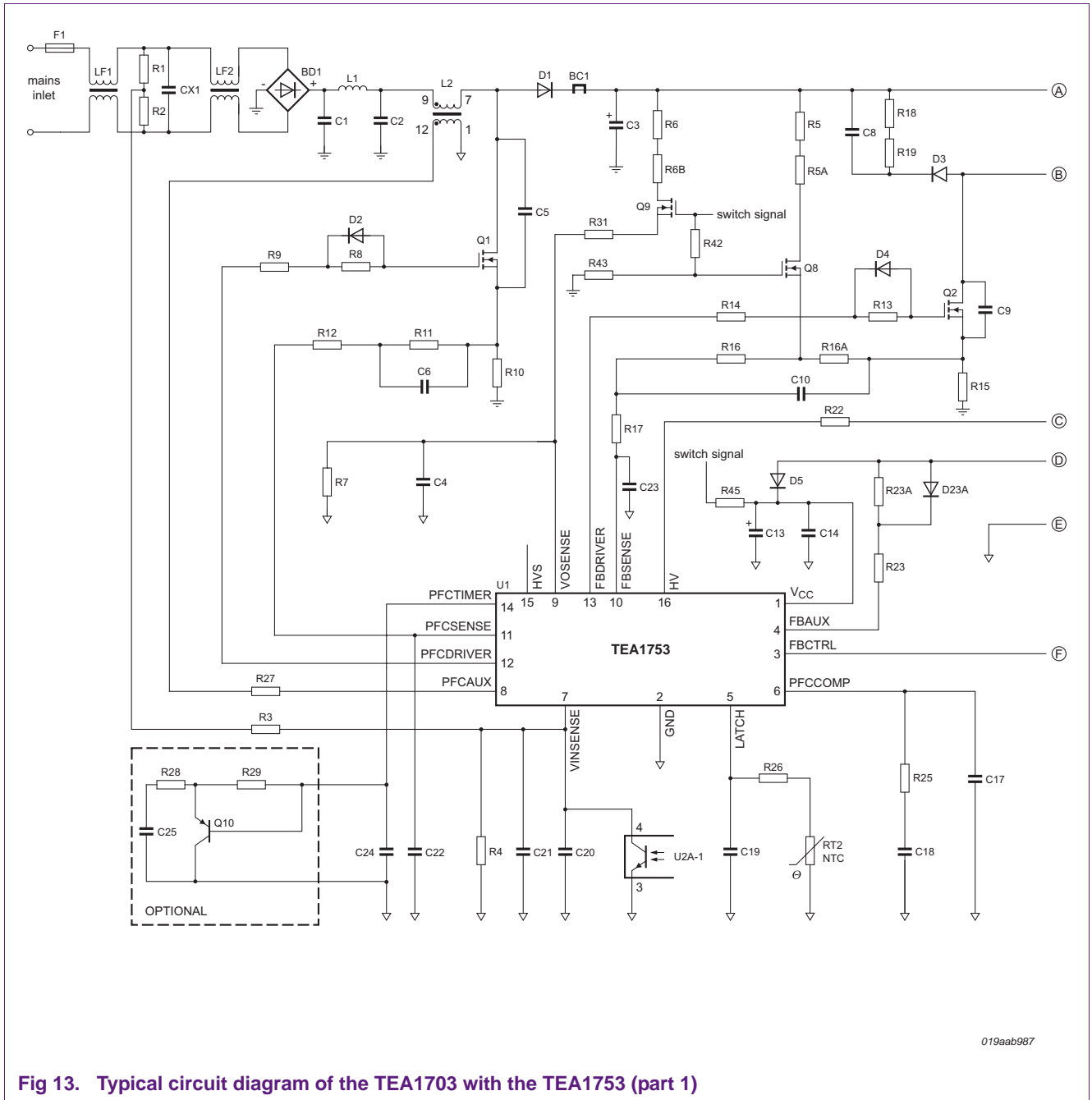

019aab987

Fig 13. Typical circuit diagram of the TEA1703 with the TEA1753 (part 1)

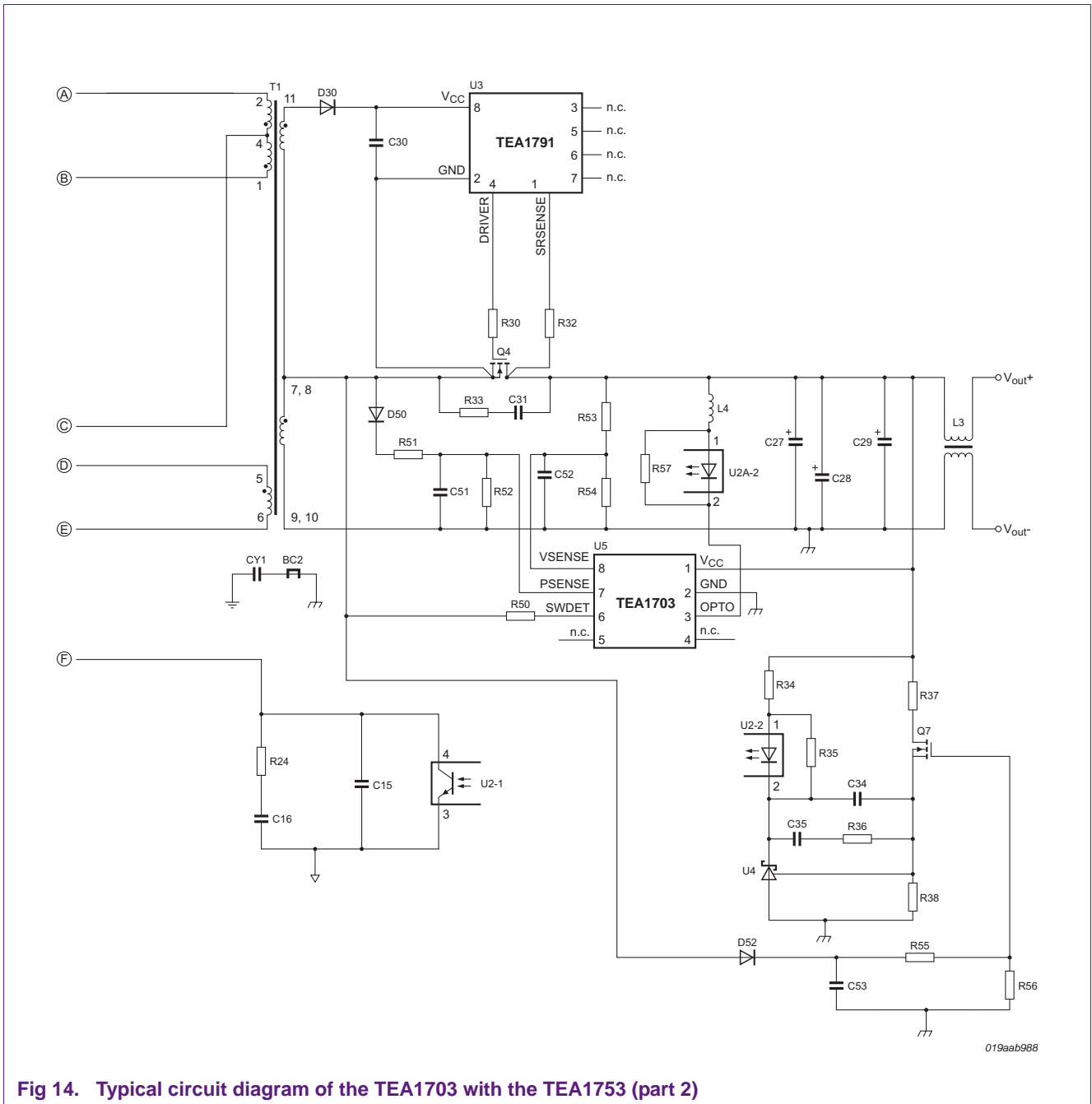

019aab988

Fig 14. Typical circuit diagram of the TEA1703 with the TEA1753 (part 2)

8.1 General description typical application

Figure 13 and Figure 14 show a typical application of the TEA1753 low cost SMPS controller and the TEA1703 standby controller. During standby operation, optocoupler U2A forces VINSENSE (pin 7 of the TEA1753) low. The SMPS stops switching when the voltage on VINSENSE drops below 0.35 V (DC).

8.2 Interfacing

To reduce standby power consumption, the TL431 reference (U4 in Figure 13 and Figure 14) and the resistor divider R37 and R38 are switched in standby by means of Q7. This reduces the standby power with 5 mW to 10 mW. The values of R55, R56 and C53 are important in relation with components R51, R52 and C51, this relationship is explained in more detail in Section 8.7.1. Resistors R55 and R56 reduce the maximum gate voltage and C53 creates a switch off delay.

Alternatively, R37 and R38 can be increased to reduce the standby power consumption. This, however, reduces the accuracy of the output voltage because of the spread on the reference input current of the TL431.

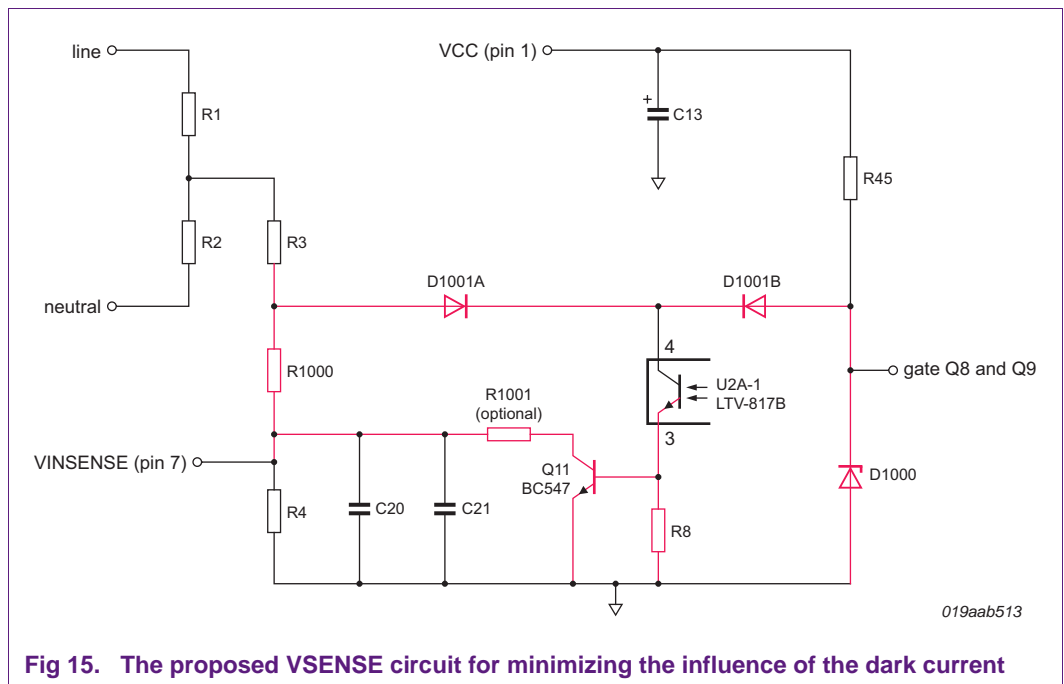

Fig 15. The proposed VSENSE circuit for minimizing the influence of the dark current

The standby information for the SMPS is obtained via optocoupler U2A. The collector of the optocoupler is not compensated for dark current. The brownout voltage can be influenced if there is no compensation for dark current. Figure 15 shows an alternative circuit diagram that compensates dark currents up to 10 μA. The red colored components in Figure 15 have to be added and components R42 and R43 can be removed in Figure 13 and Figure 14. Diode D1001A and D1001B are available in one package.

**Remark:** Dark current is the current flowing through the output of the phototransistor when it is turned off.



### 8.3 General performance

The no load standby power at 230 V (AC) of the SMPS shown in [Figure 13](#) and [Figure 14](#) is 32 mW. In standby, the output voltage varies between 19.5 V and 12.6 V. The standby output power threshold is 190 mW. This corresponds to an output current of approximately 10 mA. The worst-case power-up time from standby to maximum output current is 600 ms (with C13 = 47  $\mu$ F).

### 8.4 Standby power consumption

The 32 mW standby power at 230 V (AC) is dissipated in:

- X-cap, bridge rectifier and elcap; 2.5 mW
- VINSENSE resistors R1, R2, R3 and R4; 17 mW
- Power losses TEA1753; 5.3 mW
- $V_{CC}$  of the TEA1703, less than 0.5 mW
- Recharging the output voltage; 7 mW

The VINSENSE resistors are responsible for a substantial part of the standby power consumption.

### 8.5 Power-up behavior

When a load is connected in standby, the TEA1753 has to start-up before it can deliver full power. The start-up time (i.e. the time necessary to deliver full power) depends on the time to charge the  $V_{CC}$  capacitor. The charge time depends on the value of the VCC capacitance C13. The start-up time is approximately 580 ms if C13 is 47  $\mu$ F; see [Figure 16](#).

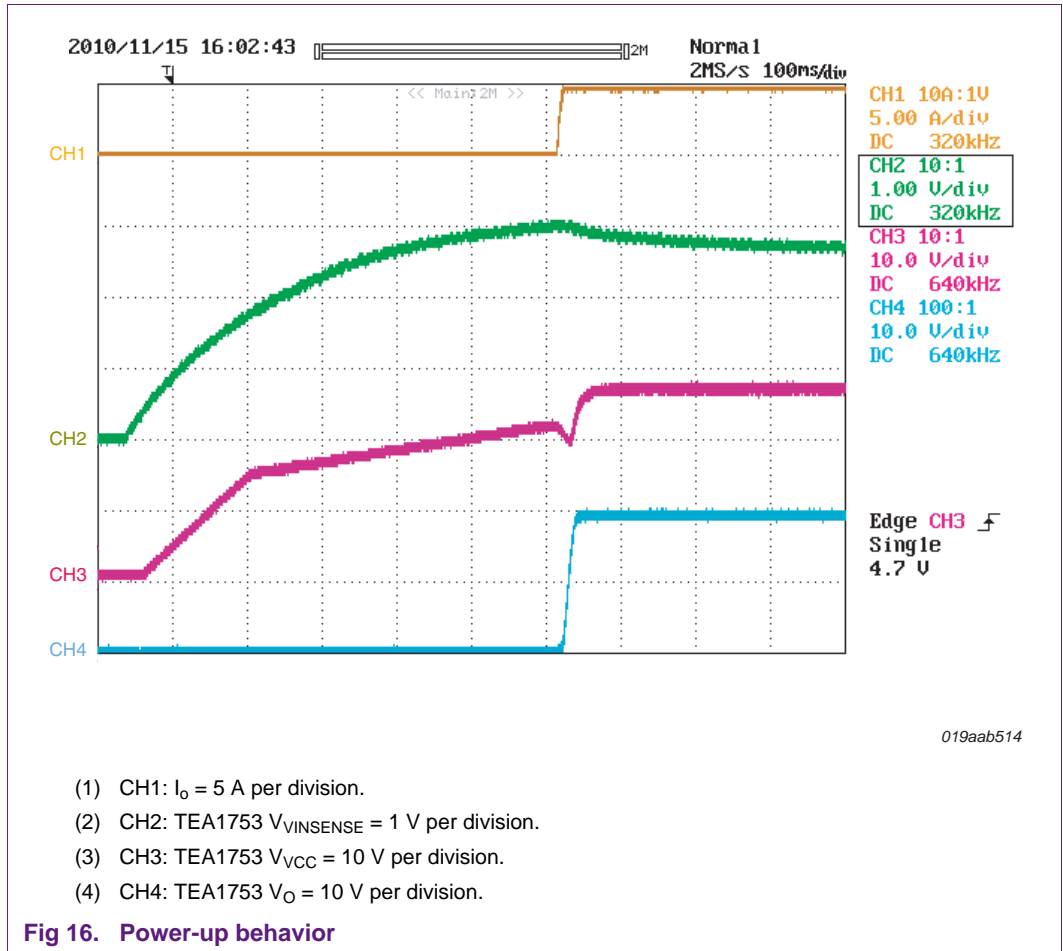

### 8.6 Power-down behavior

Figure 17 shows the power-down behavior. An extra current is driven through optocoupler U2 when the output current is minimized (during load-step).

The gate drive pulses of the flyback are now disabled for some time, see Figure 17. New FBDRIVER pulses are generated when Q7 switches off because of the discharged capacitor C53, which results in a SWDET pulse detection at the TEA1703. The first SWDET activates the OPTO output and forces the  $V_{INSENSE}$  of the TEA1753 to drop until the SMPS is forced into standby.

The TEA1753 does not generate new FBDRIVER pulses if it is forced into a latched protection, see Figure 18 (system is forced into OVP by shorting the optocoupler). Therefore the TEA1703 doesn't activate the OPTO output in such circumstances (no SWDET signal is detected during a latched protection).

Reset of the latched protection is possible by briefly removing the line voltage.

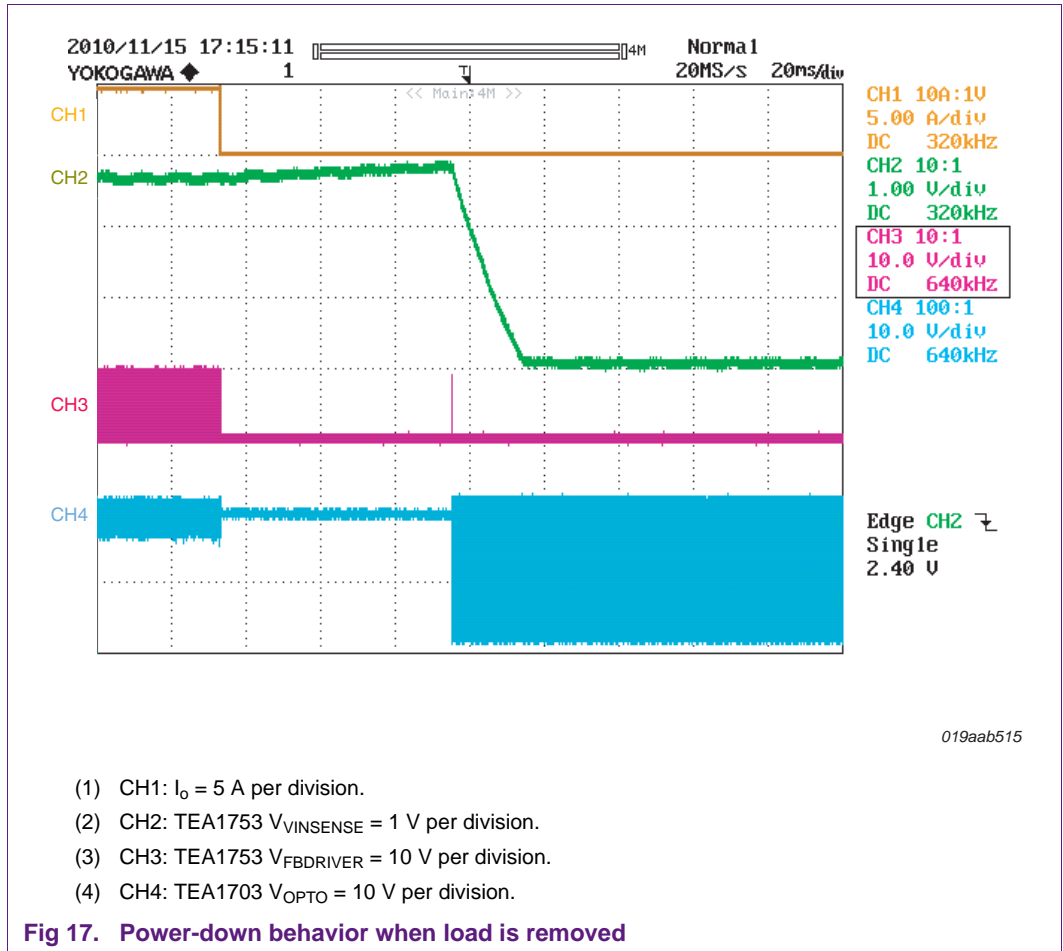

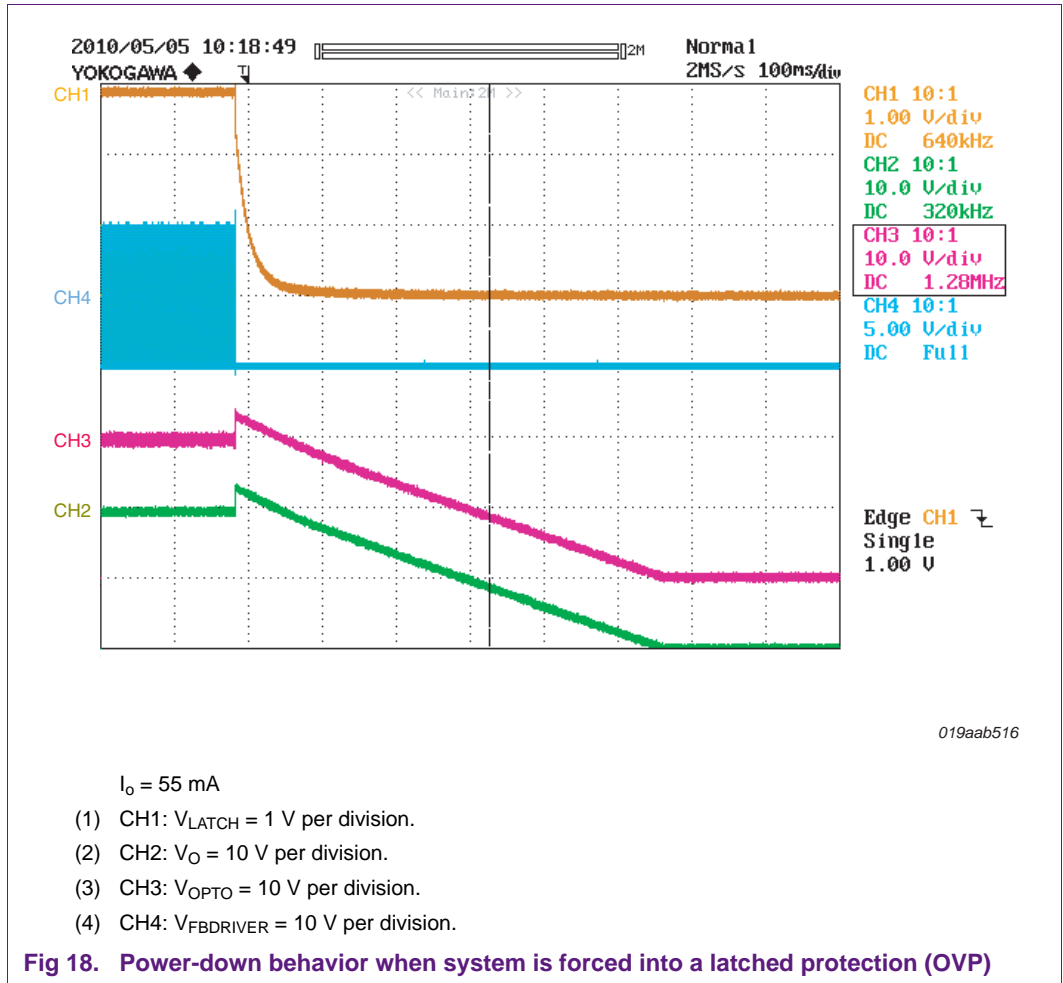

## 8.7 Adjustments

Using the component values of [Figure 13](#) and [Figure 14](#), the power level to enter standby is 190 mW and the minimum output voltage level at which the optocoupler is disabled 12.6 V. These levels can be adjusted separately. Preferably, adjusted the power level first.

### 8.7.1 Standby power threshold level adjustment

The power level to enter the standby mode can be adjusted within a certain range. Defining the values for these components depends mainly on the required minimum current value at which the system goes into standby and the speed of the selected feedback loop.

Using the circuit diagram ([Figure 13](#) and [Figure 14](#)) a capacitance value for C51 between the 27 nF and 100 nF is allowed, assuming that C51 is always equal to or slightly larger than C53.

The value of R52 determines the minimum current value at which the system enters standby. A higher resistance value for R52 results in a lower standby level current within a certain range. Using a resistance value higher than this range can easily be recognized, because it hardly has any impact on further reducing the standby current level.

The value of R52 can be found when a constant output current load is applied just above the required minimum current. The voltage across the PSENSE pin should be just above the  $V_{th(PSENSE)}$  level, so keep it just above 0.5 V (DC).

### 8.7.2 Standby behavior during small load currents

In standby, the output voltage varies between two levels. The maximum level is the output voltage of the SMPS during normal operation. The minimum level is the output voltage reached in Standby mode before the SMPS restarts. [Figure 19](#) shows the output voltage variation in Standby mode at an output currents of 9 mA and 4.5 mA. The SMPS changes from Standby mode into normal operation above an output current of approximately 9 mA.

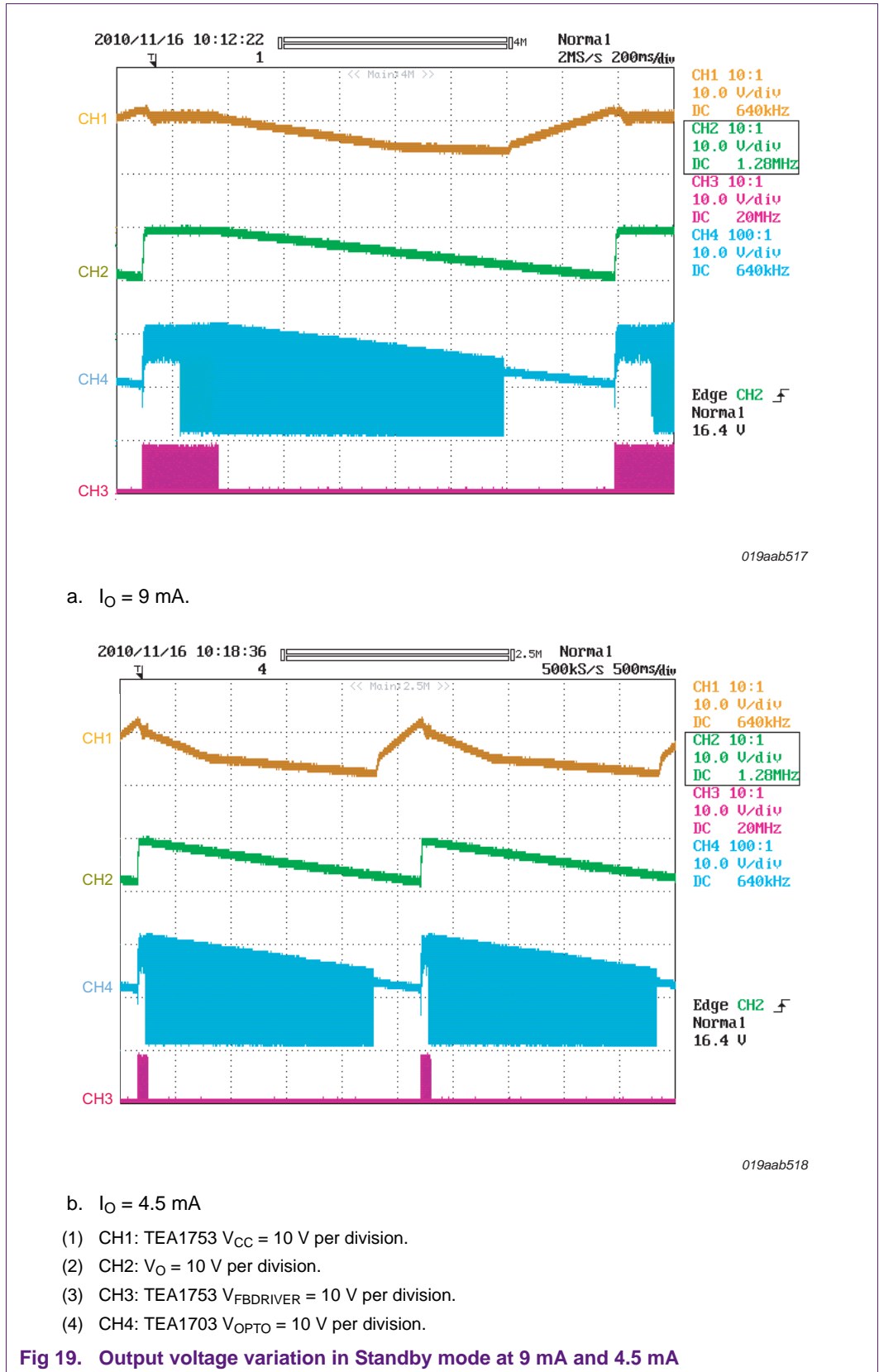

The minimum output voltage depends on the load current in Standby mode but should always be kept above the 5 V (DC). The minimum output voltage is set using the resistor divider at pin VSENSE. The minimum output voltage is almost equal to the set voltage if the output current is zero, but it drops slightly if the output is loaded with a small current. Selecting a slightly higher minimum output voltage can compensate this effect.

**8.7.2.1 Adjustment minimum  $V_O$  in standby mode (output not loaded)**

- Determine the minimum output voltage  $V_{min}$ . For minimum standby power the minimum output voltage should be as low as possible but above 5 V. At no-load there is hardly any difference between  $V_{min}$  and the set voltage  $V_{set}$ .
- Resistor  $R54 = 1.22 / (((V_{min} - 1.22) / R53) + 1e^{-6})$ . Alternatively the value for R54 can be found in [Figure 20](#). The curve is valid for  $R53 = 4.7\text{ M}\Omega$

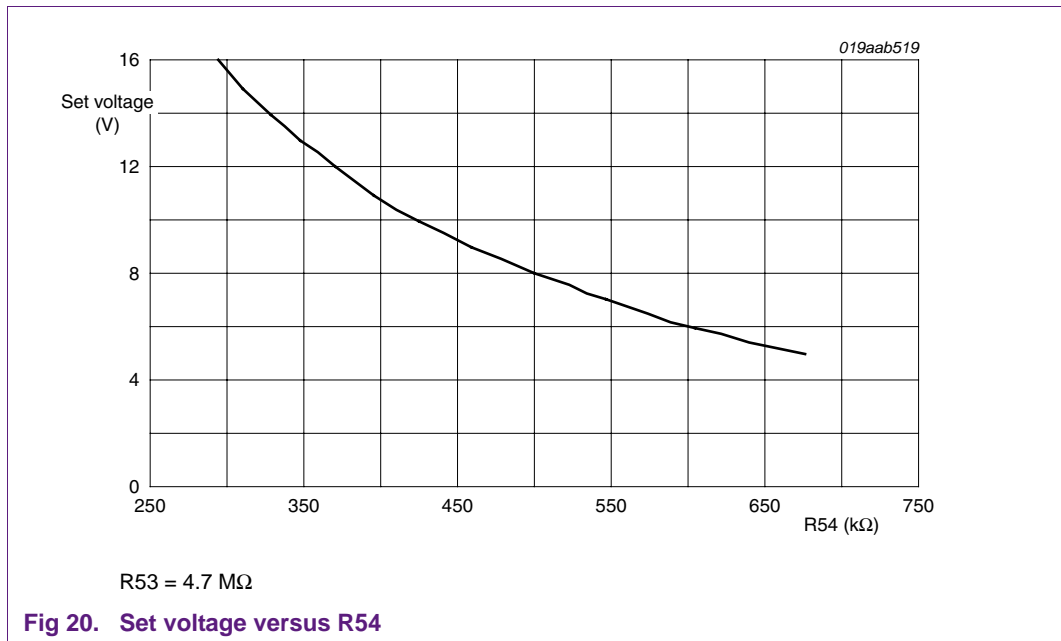

**Fig 20. Set voltage versus R54**

**8.7.3 Choosing the right coil**

When the set voltage is low, the voltage across the coil and the current through the optocoupler might become too low to force VINSENSE low and to disable the SMPS. In this situation, a lower self-inductance is an option. Be careful not to exceed the maximum peak current of the optocoupler and keep in mind that a large peak current effects the life cycle of the optocoupler and the standby power consumption.

**Remark:** Peak currents above 10 mA already have impact on the life cycle of the optocoupler.

## 9. VCC charge MOSFET with active X-cap discharge

[Figure 21](#) shows a proposal for a VCC charge MOSFET using active X-cap discharge. The main advantages compared to the typical application shown in [Figure 5](#) are:

- The VCC capacitor of the TEA1738 is charged using an increased charge current. Using the values shown in [Figure 21](#), the start-up time and power-up time is reduced to 0.25 s at 115 V (AC) and 0.2 s at 230 V (AC).
- In standby mode, the charge MOSFET M1 is disabled. This reduces the no-load standby power to approximately 10 mW
- When the mains supply voltage is disconnected, the X-cap Cx is actively discharged

The current source M1 only conducts when the mains is disconnected and during start-up of the SMPS. In all other situations, M1 is switched off to save power. In Standby mode, a low bias current maintains the loop formed by M1, U2, Q1 and the TEA1738 V<sub>CC</sub> is controlled at 0.5 V. During power-up, V<sub>CC</sub> is quickly charged by M1 and the output voltage is available within 0.25 s (depending on the load and mains voltage). R1 sets the current source charge current. The values shown in [Figure 21](#) give an average charge current of approximately 700  $\mu$ A, (the maximum clamp current on pin VCC). The maximum dark current allowed is 1.5  $\mu$ A.

[Table 3](#) gives an overview of operating modes, the MOSFET M1 gate voltage and V<sub>VINSENSE</sub>.

**Table 3. Overview of operating modes, MOSFET M1 gate voltage and V<sub>VINSENSE</sub>**

SMPS operating modes	M1 gate voltage	V <sub>VINSENSE</sub> (V) typical
Start-up	high <sup>[1][3]</sup>	≥ 0.94
Running (normal operation)	low <sup>[2]</sup>	≥ 0.72
Standby	high <sup>[4]</sup>	≤ 0.72
Running in latched protection	high <sup>[1]</sup>	≥ 0.72
AC mains supply disconnected while running	high <sup>[1][3]</sup>	≥ 0.72
AC mains supply disconnected during latched protection	high <sup>[1][3]</sup>	≥ 0.72

[1] Gate voltage approximately 10 V higher than TEA1738 V<sub>CC</sub>.

[2] Gate voltage equal to the TEA1738 V<sub>CC</sub>.

[3] Initial value.

[4] Gate voltage approximately 3.5 V higher than TEA1738 V<sub>CC</sub>.



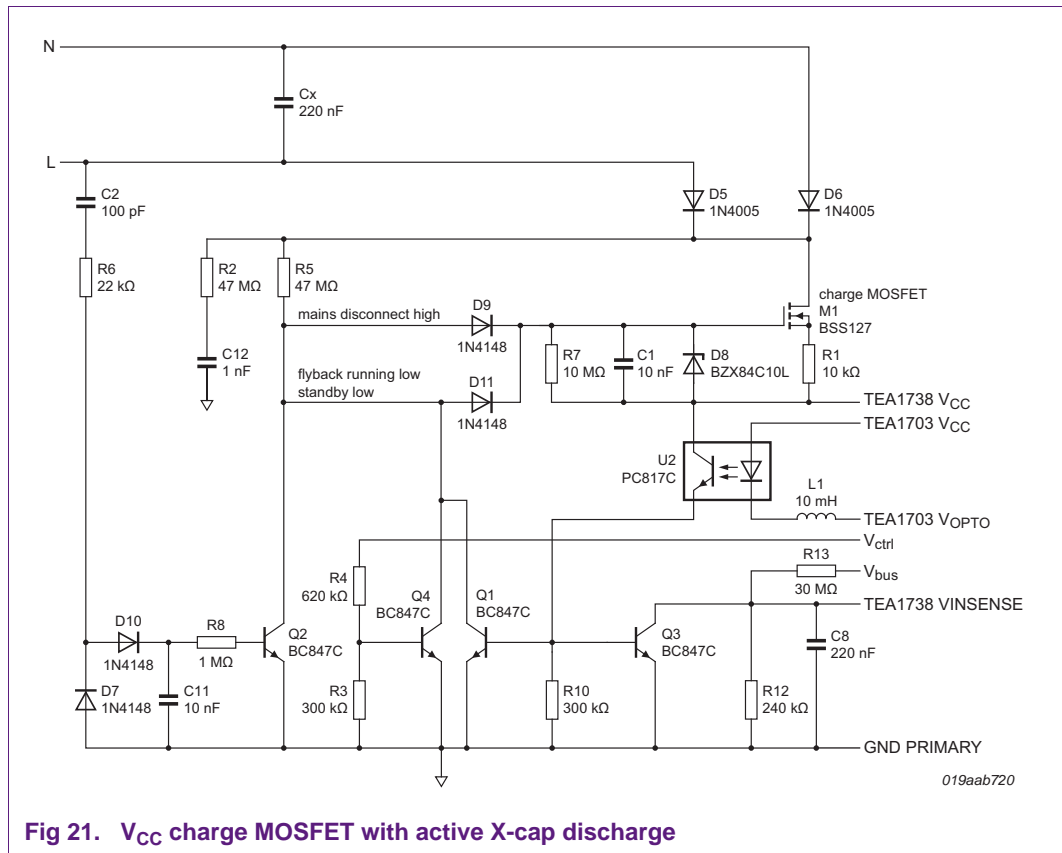

## 10. TEA1703 with LED indicator

Figure 22 shows the TEA1703 with an optional LED indicator D3. The LED is normally ON when the output power exceeds the standby power threshold.

The flyback pulses at Fly1 switch on Q1 via D4 and the RC network formed by C8, R12 and R13. Q1 switches on the output voltage feedback control via the AP431SR and, via D5 and R7, the indicator LED.

When the output power demand is less than the standby power threshold, the optocoupler pulses disable the SMPS and switch off Q1. In this situation, the optocoupler pulses drive the LED indicator with a lower drive current at a lower intensity.

The LED indicator D3 has three SMPS states: ON, OFF and standby.

A small disadvantage of the indicator LED is the lower drive voltage for coil L1. In Standby mode, when the output voltage drops, the drive current for the optocoupler may become too small. In this situation, a lower value for L1 is an option, see Section 7.7.3.

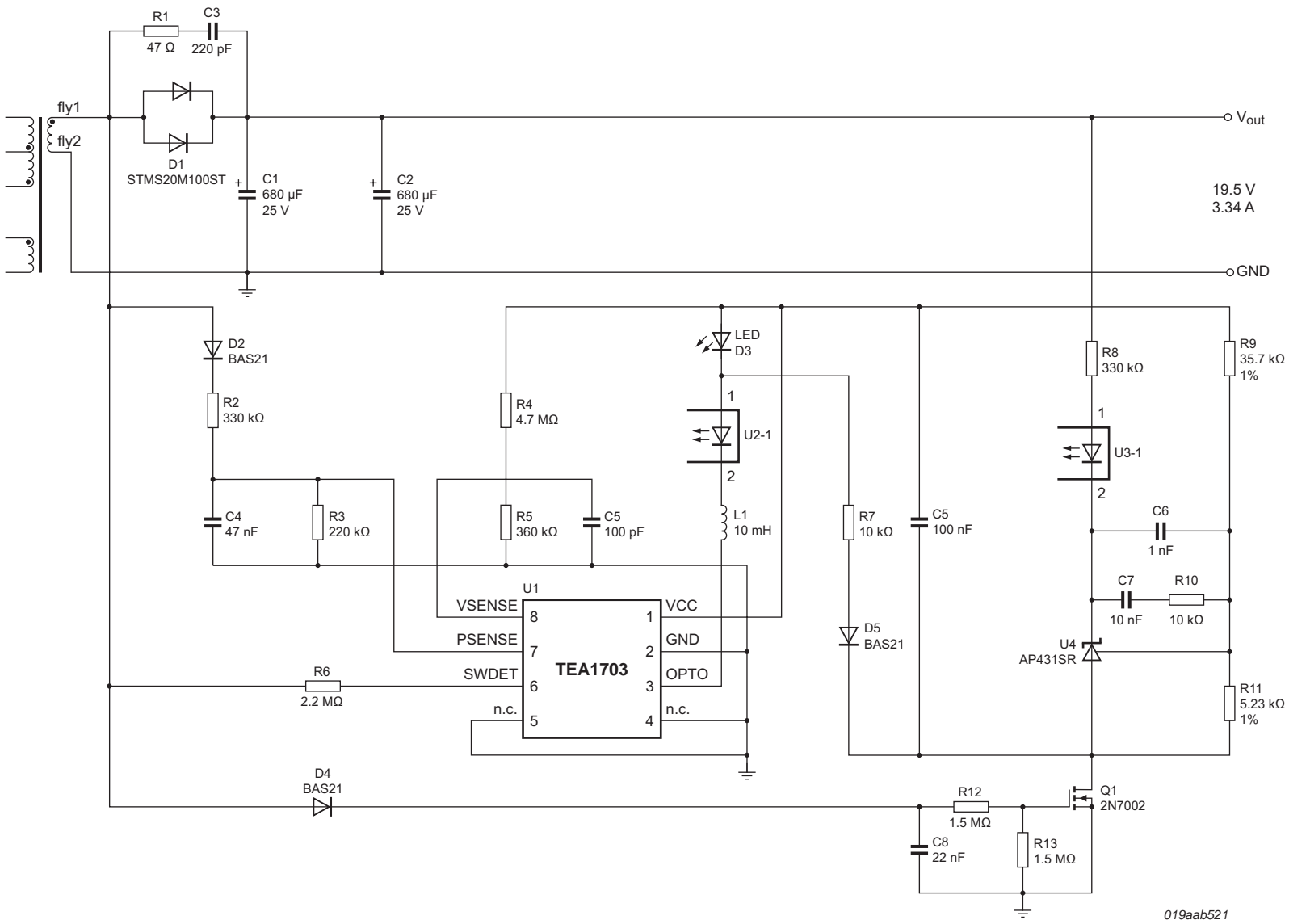

019aab521

Fig 22. TEA1703 with LED indicator

## 11. Legal information

### 11.1 Definitions

**Draft** — The document is a draft version only. The content is still under internal review and subject to formal approval, which may result in modifications or additions. NXP Semiconductors does not give any representations or warranties as to the accuracy or completeness of information included herein and shall have no liability for the consequences of use of such information.

### 11.2 Disclaimers

**Limited warranty and liability** — Information in this document is believed to be accurate and reliable. However, NXP Semiconductors does not give any representations or warranties, expressed or implied, as to the accuracy or completeness of such information and shall have no liability for the consequences of use of such information.

In no event shall NXP Semiconductors be liable for any indirect, incidental, punitive, special or consequential damages (including - without limitation - lost profits, lost savings, business interruption, costs related to the removal or replacement of any products or rework charges) whether or not such damages are based on tort (including negligence), warranty, breach of contract or any other legal theory.

Notwithstanding any damages that customer might incur for any reason whatsoever, NXP Semiconductors' aggregate and cumulative liability towards customer for the products described herein shall be limited in accordance with the *Terms and conditions of commercial sale* of NXP Semiconductors.

**Right to make changes** — NXP Semiconductors reserves the right to make changes to information published in this document, including without limitation specifications and product descriptions, at any time and without notice. This document supersedes and replaces all information supplied prior to the publication hereof.

**Suitability for use** — NXP Semiconductors products are not designed, authorized or warranted to be suitable for use in life support, life-critical or safety-critical systems or equipment, nor in applications where failure or malfunction of an NXP Semiconductors product can reasonably be expected to result in personal injury, death or severe property or environmental damage. NXP Semiconductors accepts no liability for inclusion and/or use of NXP Semiconductors products in such equipment or applications and therefore such inclusion and/or use is at the customer's own risk.

**Applications** — Applications that are described herein for any of these products are for illustrative purposes only. NXP Semiconductors makes no representation or warranty that such applications will be suitable for the specified use without further testing or modification.

Customers are responsible for the design and operation of their applications and products using NXP Semiconductors products, and NXP Semiconductors accepts no liability for any assistance with applications or customer product

design. It is customer's sole responsibility to determine whether the NXP Semiconductors product is suitable and fit for the customer's applications and products planned, as well as for the planned application and use of customer's third party customer(s). Customers should provide appropriate design and operating safeguards to minimize the risks associated with their applications and products.

NXP Semiconductors does not accept any liability related to any default, damage, costs or problem which is based on any weakness or default in the customer's applications or products, or the application or use by customer's third party customer(s). Customer is responsible for doing all necessary testing for the customer's applications and products using NXP Semiconductors products in order to avoid a default of the applications and the products or of the application or use by customer's third party customer(s). NXP does not accept any liability in this respect.

**Export control** — This document as well as the item(s) described herein may be subject to export control regulations. Export might require a prior authorization from national authorities.

**Evaluation products** — This product is provided on an "as is" and "with all faults" basis for evaluation purposes only. NXP Semiconductors, its affiliates and their suppliers expressly disclaim all warranties, whether express, implied or statutory, including but not limited to the implied warranties of non-infringement, merchantability and fitness for a particular purpose. The entire risk as to the quality, or arising out of the use or performance, of this product remains with customer.

In no event shall NXP Semiconductors, its affiliates or their suppliers be liable to customer for any special, indirect, consequential, punitive or incidental damages (including without limitation damages for loss of business, business interruption, loss of use, loss of data or information, and the like) arising out of the use of or inability to use the product, whether or not based on tort (including negligence), strict liability, breach of contract, breach of warranty or any other theory, even if advised of the possibility of such damages.

Notwithstanding any damages that customer might incur for any reason whatsoever (including without limitation, all damages referenced above and all direct or general damages), the entire liability of NXP Semiconductors, its affiliates and their suppliers and customer's exclusive remedy for all of the foregoing shall be limited to actual damages incurred by customer based on reasonable reliance up to the greater of the amount actually paid by customer for the product or five dollars (US\$5.00). The foregoing limitations, exclusions and disclaimers shall apply to the maximum extent permitted by applicable law, even if any remedy fails of its essential purpose.

### 11.3 Trademarks

Notice: All referenced brands, product names, service names and trademarks are the property of their respective owners.

**GreenChip** — is a trademark of NXP B.V.

12. Contents

<b>1</b>	<b>Introduction</b> .....	<b>3</b>	<b>10</b>	<b>TEA1703 with LED indicator</b> .....	<b>33</b>
<b>2</b>	<b>Scope and set-up of this application note.</b> ...	<b>3</b>	<b>11</b>	<b>Legal information</b> .....	<b>35</b>
2.1	Scope .....	3	11.1	Definitions .....	35
2.2	General setup of the application note.....	3	11.2	Disclaimers .....	35
2.3	Related documents and tools .....	3	11.3	Trademarks .....	35
<b>3</b>	<b>TEA1703 features</b> .....	<b>3</b>	<b>12</b>	<b>Contents</b> .....	<b>36</b>
<b>4</b>	<b>Pin description</b> .....	<b>4</b>			
<b>5</b>	<b>Application diagram</b> .....	<b>5</b>			
<b>6</b>	<b>TEA1703 description and calculation</b> .....	<b>6</b>			
6.1	General description .....	6			
6.2	Standby mode operation.....	6			
6.3	Normal operation .....	7			
6.4	PSENSE .....	8			
6.5	VSENSE .....	8			
6.6	SWDET.....	9			
6.7	Optocoupler .....	9			
<b>7</b>	<b>Typical TEA1703 and TEA1738 application</b> ..	<b>10</b>			
7.1	General description and typical application ..	11			
7.2	Interfacing .....	11			
7.3	General performance .....	12			
7.4	Standby mode power consumption.....	12			
7.5	Power-up behavior .....	13			
7.6	Power-down behavior.....	15			
7.7	Adjustments .....	15			
7.7.1	Standby mode power threshold level adjustment .....	16			
7.7.2	Minimum output voltage adjustment.....	16			
7.7.2.1	Adjustment procedure at standby no-load ...	18			
7.7.2.2	Adjustment procedure at low standby loads..	18			
7.7.3	Choosing the right coil .....	19			
<b>8</b>	<b>Typical application TEA1703 with the TEA1753</b> .....	<b>21</b>			
8.1	General description typical application.....	24			
8.2	Interfacing .....	24			
8.3	General performance .....	25			
8.4	Standby power consumption.....	25			
8.5	Power-up behavior .....	25			
8.6	Power-down behavior.....	26			
8.7	Adjustments .....	28			
8.7.1	Standby power threshold level adjustment ..	28			
8.7.2	Standby behavior during small load currents .	29			
8.7.2.1	Adjustment minimum $V_O$ in standby mode (output not loaded) .....	31			
8.7.3	Choosing the right coil .....	31			
<b>9</b>	<b>VCC charge MOSFET with active X-cap discharge</b> .....	<b>32</b>			

Please be aware that important notices concerning this document and the product(s) described herein, have been included in section 'Legal information'.

© NXP B.V. 2011.

All rights reserved.

For more information, please visit: <http://www.nxp.com>

For sales office addresses, please send an email to: [salesaddresses@nxp.com](mailto:salesaddresses@nxp.com)

Date of release: 30 March 2011

Document identifier: AN11012