

# **SN8P2714X\_2715**

## **USER'S MANUAL**

### **V1.4**

**SN8P2714**  
**SN8P27142**  
**SN8P27143**  
**SN8P2715**

## **SONiX 8-Bit Micro-Controller**

SONiX reserves the right to make change without further notice to any products herein to improve reliability, function or design. SONiX does not assume any liability arising out of the application or use of any product or circuit described herein; neither does it convey any license under its patent rights nor the rights of others. SONiX products are not designed, intended, or authorized for use as components in systems intended, for surgical implant into the body, or other applications intended to support or sustain life, or for any other application in which the failure of the SONiX product could create a situation where personal injury or death may occur. Should Buyer purchase or use SONiX products for any such unintended or unauthorized application. Buyer shall indemnify and hold SONiX and its officers, employees, subsidiaries, affiliates and distributors harmless against all claims, cost, damages, and expenses, and reasonable attorney fees arising out of, directly or indirectly, any claim of personal injury or death associated with such unintended or unauthorized use even if such claim alleges that SONiX was negligent regarding the design or manufacture of the part.

## AMENDMENT HISTORY

Version	Date	Description
VER 0.1	Aug. 2004	Preliminary Version first issue
VER 0.2	Jan. 2005	<ol style="list-style-type: none"> <li>1. Add SN8P27142/ SN8P27143 relative data.</li> <li>2. Fix ADC clock and Timer clock description.</li> <li>3. Add LVD36 relative information.</li> <li>4. Correct the LVD24 bit location from bit 3 to bit 4 in PFLAG register description.</li> <li>5. Modify LVD code option related description</li> <li>6. Modify TC0RATE and TC1RATE table.</li> <li>7. Add TC0X8 and TC1X8 notice.</li> <li>8. Release the ROM address 0x04 ~ 0x07 as general-purpose area.</li> <li>9. Remove the instruction limitation at interrupt vector address (0x08)</li> <li>10. Change IDE support version to M2IDE V1.04</li> <li>11. Modify pin circuit diagram.</li> <li>12. There is no Schmitt trigger input in port 4.</li> <li>13. Add description of P0.3 without wakeup function</li> </ol>
VER 0.3	Mar. 2005	<ol style="list-style-type: none"> <li>1. Modify Zero flag description.</li> <li>2. In instruction set table, change "S = 0", otherwise "S = 1" to "S = 1", otherwise "S = 0"</li> <li>3. Fix ADC conversion time formula.</li> <li>4. Remove "Note:For 12-bit resolution the conversion time is 16 steps".</li> <li>5. Remove "Note: Please use "@RST_WDT" macro to clear the watchdog timer successfully both in S8KD-2 ICE emulation and real chip."</li> <li>6. Modify watchdog reset section</li> <li>7. Fixed the slow mode current of electrical characteristic table.</li> </ol>
VER 1.0	Sept 2005	<ol style="list-style-type: none"> <li>1. Modify Programming Pin Mapping.</li> <li>2. Modify PROGRAM CHECK LIST.</li> <li>3. Modify P13 AVREF pin description</li> <li>4. Modify 27142/143 pin assignment.</li> <li>5. Modify P57,P66 TC0RATE、TC1RATE.</li> <li>6. Modify P57,P66:TC0X8=1 Fosc/2~Fosc/256 to Fosc/1~Fosc/128</li> <li>7. Modify P107 SLOW Mode Current.</li> <li>8. ADD P97 "Note".</li> </ol>
	Nov.2005	<ol style="list-style-type: none"> <li>1. ADD Brown-Out reset circuit.</li> <li>2. Working Voltage vs. Frequency graphs.</li> </ol>
VER 1.1	Nov.2005	<ol style="list-style-type: none"> <li>1. ADD ADC current.</li> <li>2. Modify Topr value.</li> </ol>
VER 1.2	Dec.2005	<ol style="list-style-type: none"> <li>1. Remove 32k mode.</li> <li>2. Modify P108 SN8P271XAXD to SN8P271XXD.</li> <li>3. Modify P52 wakeup trigger signal.</li> <li>4. Remove CHARACTERISTIC GRAPHS.</li> <li>5. Modify reset section.</li> <li>6. Limit Fcpu=Fosc/4~.8 when Noise Filter enable</li> <li>7. Remove Pc</li> </ol>
VER 1.3	Sep.2006	<ol style="list-style-type: none"> <li>1. Modify 15.2 STANDARD ELECTRICAL CHARACTERISTIC.</li> <li>2. Add 15.3 CHARACTERISTIC GRAPHS.</li> <li>3. Add chapter17 Marking Definition.</li> </ol>
VER 1.4	Feb 2007	<ol style="list-style-type: none"> <li>1. Modify ELECTRICAL CHARACTERISTIC.</li> <li>2. Modify RST/P0.3/VPP PIN DISCRIPTION.</li> </ol>

# Table of Contents

AMENDMENT HISTORY .....	2
<b>1 PRODUCT OVERVIEW.....</b>	<b>8</b>
1.1 FEATURES OF SN8P2710 SERIES.....	8
1.2 SYSTEM BLOCK DIAGRAM .....	10
1.3 PIN ASSIGNMENT.....	11
1.3.1 SN8P27142 Pin Assignment .....	11
1.3.2 SN8P27143 Pin Assignment .....	11
1.3.3 SN8P2714K Pin Assignment.....	12
1.3.4 SN8P2715P Pin Assignment.....	12
1.4 PIN DESCRIPTIONS.....	13
1.5 PIN CIRCUIT DIAGRAMS .....	14
<b>2 CODE OPTION TABLE.....</b>	<b>15</b>
<b>3 ADDRESS SPACES .....</b>	<b>16</b>
3.1 PROGRAM MEMORY (ROM) .....	16
3.1.1 OVERVIEW.....	16
3.1.2 USER RESET VECTOR ADDRESS (0000H).....	17
3.1.3 INTERRUPT VECTOR ADDRESS (0008H).....	17
3.1.4 GENERAL PURPOSE PROGRAM MEMORY AREA.....	19
3.1.5 LOOKUP TABLE DESCRIPTION.....	19
3.1.6 JUMP TABLE DESCRIPTION.....	21
3.2 DATA MEMORY (RAM).....	23
3.2.1 OVERVIEW.....	23
3.3 WORKING REGISTERS .....	24
3.3.1 Y, Z REGISTERS.....	24
3.3.2 R REGISTERS .....	25
3.4 PROGRAM FLAG.....	25
3.4.1 RESET FLAG .....	25
3.4.2 LVD 2.4V FLAG.....	25
3.4.3 LVD 3.6V FLAG.....	25
3.4.4 CARRY FLAG.....	26
3.4.5 DECIMAL CARRY FLAG.....	26
3.4.6 ZERO FLAG .....	26
3.5 ACCUMULATOR.....	27
3.6 STACK OPERATIONS .....	28
3.6.1 OVERVIEW.....	28

3.6.2 STACK REGISTERS.....	29
3.6.3 STACK OPERATION EXAMPLE.....	30
3.7 PROGRAM COUNTER.....	31
3.7.1 ONE ADDRESS SKIPPING.....	32
3.7.2 MULTI-ADDRESS JUMPING.....	33
<b>4 ADDRESSING MODE.....</b>	<b>34</b>
4.1 OVERVIEW.....	34
4.1.1 IMMEDIATE ADDRESSING MODE.....	34
4.1.2 DIRECTLY ADDRESSING MODE.....	34
4.1.3 INDIRECTLY ADDRESSING MODE.....	34
4.1.4 TO ACCESS DATA in RAM BANK 0.....	35
<b>5 SYSTEM REGISTER.....</b>	<b>36</b>
5.1 OVERVIEW.....	36
5.2 SYSTEM REGISTER ARRANGEMENT (BANK 0).....	36
5.2.1 BYTES of SYSTEM REGISTER.....	36
5.2.2 BITS of SYSTEM REGISTER.....	37
<b>6 RESET.....</b>	<b>39</b>
6.1 OVERVIEW.....	39
6.2 POWER ON RESET.....	40
6.3 WATCHDOG RESET.....	40
6.4 BROWN OUT RESET.....	41
6.4.1 BROWN OUT DESCRIPTION.....	41
6.4.2 THE SYSTEM OPERATING VOLTAGE DECSRIPTION.....	42
6.4.3 BROWN OUT RESET IMPROVEMENT.....	42
6.5 EXTERNAL RESET.....	44
6.6 EXTERNAL RESET CIRCUIT.....	44
6.6.1 Simply RC Reset Circuit.....	44
6.6.2 Diode & RC Reset Circuit.....	45
6.6.3 Zener Diode Reset Circuit.....	45
6.6.4 Voltage Bias Reset Circuit.....	46
6.6.5 External Reset IC.....	47
<b>7 OSCILLATORS.....</b>	<b>48</b>
7.1 OVERVIEW.....	48
7.1.1 OSCM REGISTER DESCRIPTION.....	49
7.1.2 EXTERNAL HIGH-SPEED OSCILLATOR.....	49
7.1.3 HIGH CLOCK OSCILLATOR CODE OPTION.....	49
7.1.4 SYSTEM OSCILLATOR CIRCUITS.....	50

7.1.5 External RC Oscillator Frequency Measurement.....	51
7.2 INTERNAL LOW-SPEED OSCILLATOR.....	52
7.3 SYSTEM MODE DESCRIPTION.....	53
7.3.1 OVERVIEW.....	53
7.3.2 NORMAL MODE.....	53
7.3.3 SLOW MODE.....	53
7.3.4 POWER DOWN (SLEEP) MODE.....	53
7.4 SYSTEM MODE CONTROL.....	54
7.4.1 SN8P2710 SYSTEM MODE BLOCK DIAGRAM.....	54
7.4.2 SYSTEM MODE SWITCHING.....	55
7.5 WAKEUP TIME.....	56
7.5.1 OVERVIEW.....	56
7.5.2 HARDWARE WAKEUP.....	56
<b>8 TIMERS COUNTERS.....</b>	<b>57</b>
8.1 WATCHDOG TIMER (WDT).....	57
8.2 TIMER COUNTER 0 (TC0).....	58
8.2.1 OVERVIEW.....	58
8.2.2 TC0M MODE REGISTER.....	59
8.2.3 TC0C COUNTING REGISTER.....	61
8.2.4 TC0R AUTO-LOAD REGISTER.....	63
8.2.5 TC0 TIMER COUNTER OPERATION SEQUENCE.....	64
8.2.6 TC0 CLOCK FREQUENCY OUTPUT (BUZZER).....	66
8.3 TIMER COUNTER 1 (TC1).....	67
8.3.1 OVERVIEW.....	67
8.3.2 TC1M MODE REGISTER.....	68
8.3.3 TC1C COUNTING REGISTER.....	70
8.3.4 TC1R AUTO-LOAD REGISTER.....	72
8.3.5 TC1 TIMER COUNTER OPERATION SEQUENCE.....	73
8.3.6 TC1 CLOCK FREQUENCY OUTPUT (BUZZER).....	75
8.4 PWM FUNCTION DESCRIPTION.....	76
8.4.1 OVERVIEW.....	76
8.4.2 PWM PROGRAM DESCRIPTION.....	77
8.4.3 PWM Duty with TCxR changing.....	78
8.4.4 TCxIRQ and PWM Duty.....	79
<b>9 INTERRUPT.....</b>	<b>80</b>
9.1 OVERVIEW.....	80
9.2 INTEN INTERRUPT ENABLE REGISTER.....	80
9.3 INTRQ INTERRUPT REQUEST REGISTER.....	81

9.4 P0.0 INTERRUPT TRIGGER EDGE CONTROL REGISTER .....	81
9.5 INTERRUPT OPERATION DESCRIPTION .....	82
9.5.1 GIE GLOBAL INTERRUPT OPERATION .....	82
9.5.2 INTO (P0.0) INTERRUPT OPERATION .....	83
9.5.3 INT1 (P0.1) INTERRUPT OPERATION .....	83
9.5.4 TC0 INTERRUPT OPERATION .....	85
9.5.5 TC1 INTERRUPT OPERATION .....	86
9.5.6 MULTI-INTERRUPT OPERATION .....	87
<b>10 I/O PORT .....</b>	<b>89</b>
10.1 OVERVIEW .....	89
10.2 I/O PORT FUNCTION TABLE .....	90
10.3 PULL-UP RESISTERS .....	91
10.4 I/O PORT DATA REGISTER .....	94
<b>11 8-CHANNEL ANALOG TO DIGITAL CONVERTER.....</b>	<b>96</b>
11.1 OVERVIEW .....	96
11.2 ADM REGISTER .....	97
11.3 ADR REGISTERS .....	97
11.4 ADB REGISTERS .....	97
11.5 P4CON REGISTERS .....	98
11.6 ADC CONVERTING TIME.....	99
11.7 ADC CIRCUIT .....	100
<b>12 7-BIT DIGITAL TO ANALOG CONVERTER .....</b>	<b>101</b>
12.1 OVERVIEW .....	101
12.2 DAM REGISTER .....	102
12.3 D/A CONVERTER OPERATION .....	102
<b>13 CODING ISSUE .....</b>	<b>103</b>
13.1 TEMPLATE CODE .....	103
13.2 PROGRAM CHECK LIST .....	107
<b>14 INSTRUCTION SET TABLE .....</b>	<b>108</b>
<b>15 ELECTRICAL CHARACTERISTIC .....</b>	<b>109</b>
15.1 ABSOLUTE MAXIMUM RATING.....	109
15.2 STANDARD ELECTRICAL CHARACTERISTIC.....	109
15.3 CHARACTERISTIC GRAPHS.....	110
<b>16 DEVELOPMENT TOOLS .....</b>	<b>114</b>
16.1 DEVELOPMENT TOOL VERSION .....	114

16.1.1 ICE (In circuit emulation) .....	114
16.1.2 OTP Writer .....	114
16.1.3 IDE (Integrated Development Environment) .....	114
16.2 SN8P2715/SN8P2714 EV-KIT .....	115
16.2.1 PCB DESCRIPTION.....	115
16.3 SN8P2715/14 EV-KIT CONNNECT TO SN8ICE 2K .....	116
16.4 TRANSITION BOARD FOR OTP PROGRAMMING .....	117
16.4.1 SN8P2715/2715 Rev. B TRANSITION BOARD .....	117
16.4.2 CONNNECT Rev. B TRANSITION BOARD TO EASY WRITER.....	117
16.5 OTP PROGRAMMING PIN TO TRANSITION BOARD MAPPING.....	118
16.5.1 The pin assignment of Easy and MP EZ Writer transition board socket:.....	118
16.5.2 The pin assignment of Writer V3.0 transition board socket: .....	118
16.5.3 SN8P2710 Series Programming Pin Mapping:.....	119
<b>17 MARKING DEFINITION .....</b>	<b>120</b>
17.1 INTRODUCTION.....	120
17.2 MARKING INDETIFICATION SYSTEM .....	120
17.3 MARKING EXAMPLE .....	121
17.4 DATECODE SYSTEM.....	121
<b>18 PACKAGE INFORMATION .....</b>	<b>122</b>
18.1 P-DIP18 PIN .....	122
18.2 SOP18 PIN .....	123
18.3 P-DIP 20 PIN .....	124
18.4 SOP 20 PIN .....	125
18.5 SSOP20 PIN .....	126
18.6 SK-DIP28 PIN .....	127
18.7 SOP28 PIN .....	128
18.8 P-DIP 32 PIN .....	129
18.9 SOP 32 PIN .....	129

# 1 PRODUCT OVERVIEW

## 1.1 FEATURES of SN8P2710 Series

- ◆ **Memory configuration**  
OTP ROM size: 2K \* 16 bits.  
RAM size: 128 \* 8 bits  
Eight levels stack buffer
- ◆ **I/O pin configuration**  
Input only pin: P0  
Bi-directional: P2, P4, P5  
Wakeup: P0.0, P0.1, P0.2  
External interrupt: P0.0, P0.1  
Pull-up resistors: P0, P2, P4, P5  
P4 pins shared with ADC inputs.
- ◆ **Max 8-channel 12-bit ADC.**
- ◆ **One channel 7-bit DAC.**
- ◆ **Powerful instructions**  
**One clocks per instruction cycle (1T)**  
Most of instructions are one cycle only  
All ROM area lookup table function (MOVC)
- ◆ **Four interrupt sources**  
Two internal interrupts: TC0, TC1  
Two external interrupts: INT0, INT1
- ◆ **Two 8-bit Timer/Counter**  
TC0: Auto-reload timer/Counter/PWM0/Buzzer output  
TC1: Auto-reload timer/Counter/PWM1/Buzzer output
- ◆ **On chip watchdog timer.**
- ◆ **System clocks and Operating modes**  
External high clock: RC type up to 10 MHz  
External high clock: Crystal type up to 16 MHz  
Internal low clock: RC type 16KHz(3V), 32KHz(5V)  
Normal mode: Both high and low clock active  
Sleep mode: Low clock only  
Sleep mode: Both high and low clock stop
- ◆ **Package (Chip form support)**  
SN8P27142: P-DIP 18 pins, SOP 18pins  
SN8P27143: P-DIP 20 pins, SOP 20 pins, SSOP 20 pins  
SN8P2714: SK-DIP 28 pins, SOP 28pins  
SN8P2715: P-DIP 32 pins, SOP 32 pins

### FEATURES SELECTION TABLE

CHIP	ROM	RAM	Stack	Timer			I/O	ADC	DAC	PWM	SIO	Wakeup Pin no.	Package
				T0	TC0	TC1				Buzzer			
SN8P27142	2K*16	128	8	-	V	V	15	5ch	-	2	-	2	DIP18/SOP18
SN8P27143	2K*16	128	8	-	V	V	16	6ch	-	2	-	2	DIP20/SOP20/SSOP20
SN8P2714	2K*16	128	8	-	V	V	23	8ch	1ch	2	-	3	SKDIP28/SOP28
SN8P2715	2K*16	128	8	-	V	V	27	8ch	1ch	2	-	3	DIP32/SOP32
SN8P2704A	4K*16	256	8	V	V	V	18	5ch	1ch	2	1	8	SKDIP28/SOP28
SN8P2705A	4K*16	256	8	V	V	V	23	8ch	1ch	2	1	9	DIP32/SOP32

Note: For SN8P27143 and SN8P27142 must configure P02R (bit 2 of P0UR) as "1" to avoid sleep mode fail.



**Compare SN8P2714/15 to SN8P2704A/05A**

Item	SN8P2714/15	SN8P2704A/05A
AC Noise Immunity Capability	Excellent <b>(Add an 47uF bypass Capacitor between VDD and GND)</b>	Excellent <b>(Add an 47uF bypass Capacitor between VDD and GND)</b>
Memory	ROM: 2K x 16 RAM: 128 x 8	ROM: 4K x 16 RAM: 256 x 8
Maximum I/O pins	23 I/O in 28 pins package 27 I/O in 32 pins package	18 I/O in 28 pins package 23 I/O in 32 pins package
High Speed PWM	PWM Resolution: 8bit/6bit/5bit/4bit 8bit PWM up to 62.5K at 16Mhz 4bit PWM up to 1000K at 16Mhz	PWM Resolution: 8bit/6bit/5bit/4bit 8bit PWM up to 7.8125K at 16Mhz 4bit PWM up to 125K at 16Mhz
Programmable Open-Drain Output	N/A	P1.0 / P1.1 / P5.2 (SO)
B0MOV M, I	No Limitation	"I" can't be 0E6h or 0E7h
B0XCH A, M	No Limitation	The address of M can't be 80h ~ FFh
Valid instruction in ROM address 8	No Limitation	JMP or NOP
ADC Interrupt	No	Yes
ADC Clock Frequency	Four kinds of setting (Configuration by ADCKS [1:0])	Seven kinds of setting (Configuration by ADCKS [2:0])
Valid Range of TC0C/TC1C/TC0R/TC1R	0x00 ~ 0xFF	0x00 ~ 0xFE
Green mode	No	Yes
SIO Function	No	Yes
LVD	Level: 2.0V always ON	1.8V always ON
Port 0	Input only port	Bi-direction port
Interrupt Vector Instruction	No Limitation	NOP/JMP only
PUSH/POP Instruction	No	Yes

## 1.2 SYSTEM BLOCK DIAGRAM

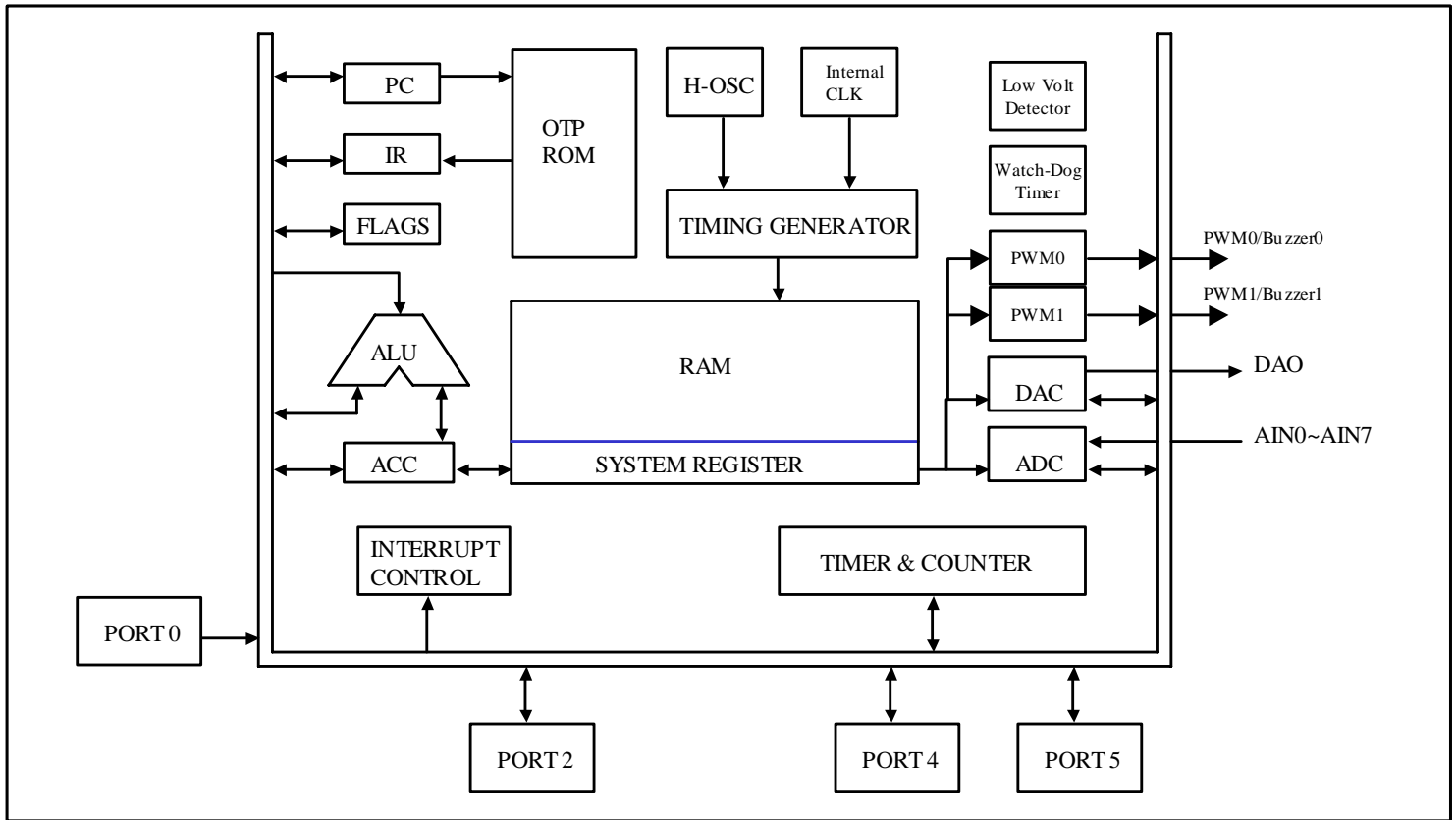

**Figure 1-1.Simplified System Block Diagram**

## 1.3 PIN ASSIGNMENT

Format Description : SN8P271xY     $\underline{Y}$  = K > SK-DIP , P > P-DIP , S > SOP

### 1.3.1 SN8P27142 Pin Assignment

P0.1	1	U	18	P0.0
P2.0	2		17	P5.0
P2.1	3		16	P5.1
P5.6/XOUT	4		15	P5.3/BZ1/PWM1
XIN	5		14	P5.4/BZ0/PWM0
VSS	6		13	P0.3/RST/VPP
P4.4/AIN4	7		12	VDD
P4.3/AIN3	8		11	P4.0/AIN0
P4.2/AIN2	9		10	P4.1/AIN1

SN8P27142P  
SN8P27142S

### 1.3.2 SN8P27143 Pin Assignment

P2.0	1	U	20	P0.1
P2.1	2		19	P0.0
P5.6/XOUT	3		18	P5.0
XIN	4		17	P5.1
VSS	5		16	P5.3/BZ1/PWM1
P4.5/AIN5	6		15	P5.4/BZ0/PWM0
P4.4/AIN4	7		14	P0.3/RST/VPP
P4.3/AIN3	8		13	VDD
P4.2/AIN2	9		12	AVREFH
P4.1/AIN1	10		11	P4.0/AIN0

SN8P27143P  
SN8P27143S  
SN8P27143X

- **Note:** For SN8P27143 and SN8P27142 must configure P02R (bit 2 of P0UR) as “1” to avoid sleep mode fail.
- **Note:** The ADC reference voltage (AVREFH) of SN8P27142/SN8P27143 is VDD.

### 1.3.3 SN8P2714K Pin Assignment

P5.3/BZ1/PWM1	1	U	28	P5.4/BZ0/PWM0
P5.2	2		27	DAC
P5.1	3		26	P0.3/RST/VPP
P5.0	4		25	VDD
P0.0/INT0	5		24	AVREFH
P0.1/INT1	6		23	P4.0/AIN0
P0.2	7		22	P4.1/AIN1
P2.0	8		21	P4.2/AIN2
P2.1	9		20	P4.3/AIN3
P2.2	10		19	P4.4/AIN4
P2.3	11		18	P4.5/AIN5
P2.4	12		17	P4.6/AIN6
P5.6/XOUT	13		16	P4.7/AIN7
XIN	14		15	VSS

SN8P2714K  
SN8P2714S

### 1.3.4 SN8P2715P Pin Assignment

P5.5	1	U	32	DAO
P5.4/BZ0/PWM0	2		31	P0.3/RST/VPP
P5.3/BZ1/PWM1	3		30	VDD
P5.2	4		29	AVREFH
P5.1	5		28	P4.0/AIN0
P5.0	6		27	P4.1/AIN1
P0.0/INT0	7		26	P4.2/AIN2
P0.1/INT1	8		25	P4.3/AIN3
P0.2	9		24	P4.4/AIN4
P2.0	10		23	P4.5/AIN5
P2.1	11		22	P4.6/AIN6
P2.2	12		21	P4.7/AIN7
P2.3	13		20	VSS
P2.4	14		19	XIN
P2.5	15		18	P5.6/XOUT
P2.6	16		17	P2.7

SN8P2715P  
SN8P2715S

## 1.4 PIN DESCRIPTIONS

PIN NAME	TYPE	DESCRIPTION
P0 [1:0] / INT [1:0]	I	P0 [1:0]: Input only pin/ wakeup/pull-up/Schmitt trigger input INT [1:0]: External interrupt
P0 .2	I	P0.2: Input only pin/wake up/pull-up/Schmitt trigger input
P2 [7:0]	I/O	P2 [7:0] bi-direction pins/pull-up/Schmitt trigger input
P4 [7:0] / AIN [7:0]	I/O	Bi-direction pins/pull-up /ADC input/ <b>without</b> Schmitt trigger input
P5 [5:0]	I/O	Bi-direction pins/pull-up/Schmitt trigger input P5.4: PWM0/BZ0, P5.3: PWM1/BZ1
AVREFH	I	ADC highest reference voltage input (NOTE :The ADC reference voltage (AVREFH) of SN8P27142 and SN8P27143 are VDD.)
DAO	O	Current type DAC output
P0.3/RST/VPP	I/P	P0.3: Schmitt trigger input pin / <b>NO pull-up, NO wakeup/</b> in RC mode P0.3 is input only pin without pull-up resistor under P0.3 mode. Add the 100 ohm external resistor on P0.3, when it is set to be input pin. RST: External reset, active "low" VPP: OTP programming pin
XIN	I	External oscillator input pin. / External RC oscillator input
XOUT/P5.6	I/O	XOUT: External oscillator output pin. P5.6: Bi-direction pin/pull-up/Schmitt trigger input in RC mode
VDD, VSS	P	Power supply pins.

Table 1-1. SN8P2714/15 Pin Description

## 1.5 PIN CIRCUIT DIAGRAMS

Port 0.1 and P0.2 structure:

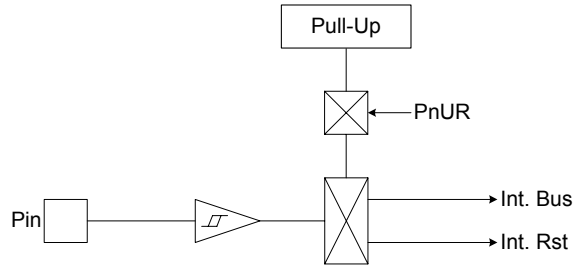

Port 0.3 structure:

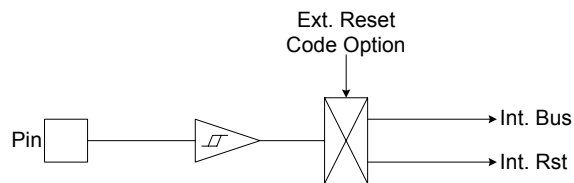

Port 2, 5 structure:

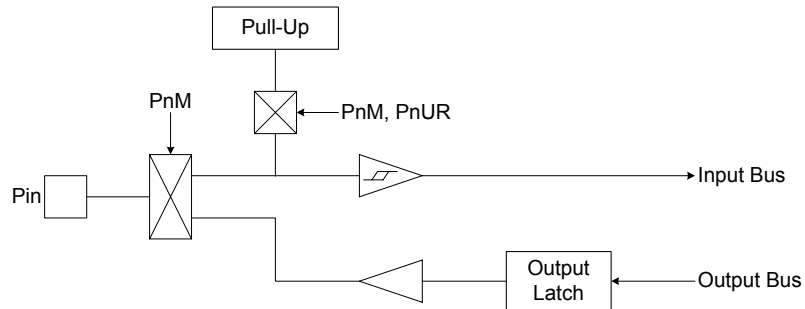

Port 4 structure:

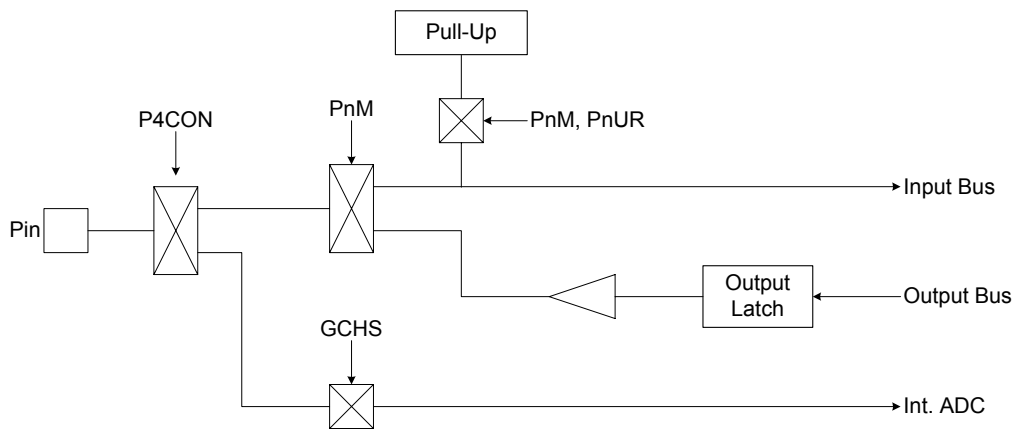

Figure 1-2. Pin Circuit Diagram

# 2 CODE OPTION TABLE

Code Option	Content	Function Description
High_Clk	Ext_RC	Low cost external RC oscillator for high clock oscillator. Output the Fcpu clock from Xout pin.
	12M_X'tal	High speed crystal /resonator (e.g. 12MHz ~ 16MHz) for high clock oscillator.
	4M_X'tal	Middle speed crystal /resonator (e.g. 4MHz ~ 10MHz) for high clock oscillator.
Noise_Filter	Enable	Enable Noise Filter and the Fcpu is Fosc/4~Fosc/8.
	Disable	Disable Noise Filter and the Fcpu is Fosc/1~Fosc/8.
Watch_Dog	Always_On	Watchdog timer always on even in sleep (power down) mode.
	Enable	Normal mode: Enable Watchdog timer Sleep mode: Stop Watchdog timer Stop
	Disable	Disable Watchdog function.
Fcpu	Fosc/1	Instruction cycle is oscillator clock. Notice: In Fosc/1, Noise Filter must be disabled.
	Fosc/2	Instruction cycle is 2 oscillator clocks. Notice: In Fosc/2, Noise Filter must be disabled.
	Fosc/4	Instruction cycle is 4 oscillator clocks.
	Fosc/8	Instruction cycle is 8 oscillator clocks.
Security	Enable	Enable ROM code Security function.
	Disable	Disable ROM code Security function.
RST_P0.3	Reset	Enable external reset pin
	P0.3	Enable P0.3 input only pin without pull-up register
LVD	LVD_L	LVD will reset chip if VDD is below 2.0V
	LVD_M	LVD will reset chip if VDD is below 2.0V Enable LVD24 bit of PFLAG register for 2.4V low voltage indicator.
	LVD_H	LVD will reset chip if VDD is below 2.4V Enable LVD36 bit of PFLAG register for 3.6V low voltage indicator.

Table 2-1. Code Option Table of SN8P2714x/2715

### Notice:

- In high noisy environment, enable “Noise Filter” and set Watch\_Dog as “Always\_On” is strongly recommended.
- Enable “Noise Filter” will limit the Fcpu = Fosc/4 or Fosc/8
- Fcpu code option is only available for High Clock
- Fosc = Fosc (External high clock) in normal mode.
- Fosc = Fosc (Internal low RC clock) in slow mode.
- In slow mode, Fcpu = Fosc / 4.

# 3 ADDRESS SPACES

## 3.1 PROGRAM MEMORY (ROM)

### 3.1.1 OVERVIEW

ROM Maps for SN8P2710 devices provide 2K X 16-bit OTP programmable memory. The SN8P2710 program memory is able to fetch instructions through 12-bit wide PC (Program Counter) and can look up ROM data by using ROM code registers (R, X, Y, Z). In standard configuration, the device's 2,048 x 16-bit program memory has four areas:

- 1-word reset vector addresses
- 1-word Interrupt vector addresses
- 4-words reserved area
- 2K words

All of the program memory is partitioned into three coding areas. The 1<sup>st</sup> area is located from 00H to 07H(The Reset vector area), the 2<sup>nd</sup> area is for the interrupt vector (0008H) and the 3<sup>ed</sup> area is user code area from 0009H to 07FBH.

ROM		
0000H	<b>Reset vector</b>	User reset vector
0001H	<b>General purpose area</b>	Jump to user start address
0002H		Jump to user start address
0003H		Jump to user start address
0004H		Jump to user start address
0005H		Jump to user start address
0006H		Jump to user start address
0007H		Jump to user start address
0008H	<b>Interrupt vector</b>	User interrupt vector
0009H	<b>General purpose area</b>	User program
.		
.		
000FH		
0010H		
0011H		
.		
07FBH		End of user program
07FCH	<b>Code Option</b>	
07FFH		

Figure 3-1 ROM Address Structure



### 3.1.2 USER RESET VECTOR ADDRESS (0000H)

A 1-word vector address area is used to execute system reset. After power on reset or watchdog timer overflow reset, then the chip will restart the program from address 0000h and all system registers will be set as default values. The following example shows the way to define the reset vector in the program memory.

⇒ **Example: After power on reset, external reset active or reset by watchdog timer overflow.**

```

    ORG      0           ; 0000H
    JMP     START       ; Jump to user program address.
    .
    .
    .
START:    ORG      10H          ; 0010H, The head of user program.
    .
    .
    .
    ENDP           ; End of program

```

### 3.1.3 INTERRUPT VECTOR ADDRESS (0008H)

A 1-word vector address area is used to execute interrupt request. If any interrupt service is executed, the program counter (PC) value is stored in stack buffer and points to 0008h of program memory to execute the vectored interrupt. Users have to define the interrupt vector and the following example shows the way to define the interrupt vector in the program memory.

⇒ **Example 1: This demo program includes interrupt service routine and the user program is behind the interrupt service routine.**

```

    ORG      0           ; 0000H
    JMP     START       ; Jump to user program address.
    .
    .
    .
    ORG      8           ; Interrupt service routine
    B0XCH   A, ACCBUF   ; B0XCH doesn't change C, Z flag
    B0MOV   A, PFLAG
    B0MOV   PFLAGBUF, A ; Save PFLAG register in a buffer
    .
    .
    .
    B0MOV   A, PFLAGBUF ; Restore PFLAG register from buffer
    B0MOV   PFLAG, A
    B0XCH   A, ACCBUF
    RETI           ; End of interrupt service routine

START:    .
    .
    .
    JMP     START       ; End of user program

    ENDP           ; End of program

```

⇒ Example 2: The demo program includes interrupt service routine and the address of interrupt service routine is in a special address of general-purpose area.

```

                ORG      0          ; 0000H
                JMP      START     ; Jump to user program address.
                .              ; 0001H ~ 0007H are reserved

                ORG      08
                JMP      MY_IRQ    ; 0008H, Jump to interrupt service routine address

START:          ORG      10H
                .              ; 0010H, The head of user program.
                .              ; User program
                .
                .
                JMP      START     ; End of user program

MY_IRQ:        ;The head of interrupt service routine
                B0XCH   A, ACCBUF  ; B0XCH doesn't change C, Z flag
                B0MOV   A, PFLAG
                B0MOV   PFLAGBUF, A ; Save PFLAG register in a buffer
                .              ; User code
                .              ; User code
                B0MOV   A, PFLAGBUF
                B0MOV   PFLAG, A   ; Restore PFLAG register from buffer
                RETI              ; End of interrupt service routine

                ENDP              ; End of program

```

➤ Note: It is easy to get the rules of SONiX program from demo programs given above. These points are as following.

1. The address 0000H is a "JMP" instruction to make the program go to general-purpose ROM area.

2. The interrupt service starts from 0008H. Users can put the whole interrupt service routine from 0008H (Example1) or to put a "JMP" instruction in 0008H then place the interrupt service routine in other general-purpose ROM area (Example2) to get more modularized coding style.

### 3.1.4 GENERAL PURPOSE PROGRAM MEMORY AREA

The ROM locations 0001H~0007H and 0009H~07FBH are used as general-purpose memory. The area is stored instruction's op-code and look-up table data. The SN8P2710 includes jump table function by using program counter (PC) and look-up table function by using ROM code registers (R, Y, Z).

The boundary of program memory is separated by the high-byte program counter (PCH) every 100H. In jump table function and look-up table function, the program counter can't leap over the boundary by program counter automatically. Users need to modify the PCH value to "PCH+1" as the PCL overflow (from 0FFH to 000H).

### 3.1.5 LOOKUP TABLE DESCRIPTION

In the ROM's data lookup function, Y register to the highest 8-bit and Z register to the lowest 8-bit data of ROM address. After MOVC instruction is executed, the low-byte data of ROM then will be stored in ACC and high-byte data stored in R register.

➤ **Example: To look up the ROM data located "TABLE1".**

```

        B0MOV    Y, #TABLE1$M    ; To set lookup table1's middle address
        B0MOV    Z, #TABLE1$L    ; To set lookup table1's low address.
        MOVC     ; To lookup data, R = 00H, ACC = 35H
        ;
        ; Increment the index address for next address
        INCMS    Z              ; Z+1
        JMP      @F             ; Not overflow
        INCMS    Y              ; Z overflow (FFH → 00), → Y=Y+1
        NOP      ; Not overflow
        ;
@@:     MOVC     ; To lookup data, R = 51H, ACC = 05H.
        ;
TABLE1: DW      0035H          ; To define a word (16 bits) data.
        DW      5105H          ; "
        DW      2012H          ; "

```

➤ **CAUTION:** The Y register can't increase automatically if Z register cross boundary from 0xFF to 0x00. Therefore, user must take care such situation to avoid loop-up table errors. If Z register overflow, Y register must be added one. The following INC\_YZ macro shows a simple method to process Y and Z registers automatically.

➤ **Note:** Because the program counter (PC) is only 12-bit, the X register is useless in the application. Users can omit "B0MOV X, #TABLE1\$H". SONiX ICE support more larger program memory addressing capability. So make sure X register is "0" to avoid unpredicted error in loop-up table operation.

➤ **Example: INC\_YZ Macro**

```

INC_YZ    MACRO
        INCMS    Z              ; Z+1
        JMP      @F             ; Not overflow

        INCMS    Y              ; Y+1
        NOP      ; Not overflow
@@:
        ENDM

```

The other coding style of loop-up table is to add Y or Z index register by accumulator. Be careful if carry happen. Refer following example for detailed information:

➤ **Example: Increase Y and Z register by B0ADD/ADD instruction**

```

B0MOV    Y, #TABLE1$M    ; To set lookup table's middle address.
B0MOV    Z, #TABLE1$L    ; To set lookup table's low address.

B0MOV    A, BUF          ; Z = Z + BUF.
B0ADD    Z, A

B0BTS1   FC              ; Check the carry flag.
JMP      GETDATA        ; FC = 0
INCMS    Y               ; FC = 1. Y+1.
NOP

GETDATA:
MOV      MOVC             ;
                ; To lookup data. If BUF = 0, data is 0x0035
                ; If BUF = 1, data is 0x5105
                ; If BUF = 2, data is 0x2012
                .
                .
                .
                .
                .
TABLE1:   .
          DW    0035H    ; To define a word (16 bits) data.
          DW    5105H    ; "
          DW    2012H    ; "

```

### 3.1.6 JUMP TABLE DESCRIPTION

The jump table operation is one of multi-address jumping function. Add low-byte program counter (PCL) and ACC value to get one new PCL. The new program counter (PC) points to a series jump instructions as a listing table. The way is easy to make a multi-stage program.

When carry flag occurs after executing of "ADD PCL, A", it will not affect PCH register. Users have to check if the jump table leaps over the ROM page boundary or the listing file generated by SONiX assembly software. If the jump table leaps over the ROM page boundary (e.g. from xxFFH to xx00H), move the jump table to the top of next program memory page (xx00H). **Here one page mean 256 words.**

⇒ **Example : If PC = 0323H (PCH = 03H, PCL = 23H)**

```

ORG      0X0100      ; The jump table is from the head of the ROM boundary

B0ADD    PCL, A      ; PCL = PCL + ACC, the PCH can't be changed.
JMP      A0POINT    ; ACC = 0, jump to A0POINT
JMP      A1POINT    ; ACC = 1, jump to A1POINT
JMP      A2POINT    ; ACC = 2, jump to A2POINT
JMP      A3POINT    ; ACC = 3, jump to A3POINT

```

In following example, the jump table starts at 0x00FD. When execute B0ADD PCL, A. If ACC = 0 or 1, the jump table points to the right address. If the ACC is larger than 1 will cause error because PCH doesn't increase one automatically. We can see the PCL = 0 when ACC = 2 but the PCH still keep in 0. The program counter (PC) will point to a wrong address 0x0000 and crash system operation. It is important to check whether the jump table crosses over the boundary (xxFFH to xx00H). A good coding style is to put the jump table at the start of ROM boundary (e.g. 0100H).

⇒ **Example: If "jump table" crosses over ROM boundary will cause errors.**

ROM Address

```

.      .
.      .
.      .
0X00FD B0ADD    PCL, A      ; PCL = PCL + ACC, the PCH can't be changed.
0X00FE JMP      A0POINT    ; ACC = 0
0X00FF JMP      A1POINT    ; ACC = 1
0X0100 JMP      A2POINT    ; ACC = 2 ← jump table cross boundary here
0X0101 JMP      A3POINT    ; ACC = 3
.      .
.      .

```

SONiX provides a macro for safe jump table function. This macro will check the ROM boundary and move the jump table to the right position automatically. The side effect of this macro is maybe wasting some ROM size. Notice the maximum jmp table number for this macro is limited under 254.

```

@JMP_A      MACRO      VAL
IF          (($+1) !& 0XFF00) != (($+(VAL)) !& 0XFF00)
JMP        ($ | 0XFF)
ORG        ($ | 0XFF)
ENDIF
ADD        PCL, A
ENDM

```

➤ **Note: "VAL" is the number of the jump table listing number.**

⇒ Example: “@JMP\_A” application in SONIX macro file called “MACRO3.H”.

```
B0MOV    A, BUF0        ; “BUF0” is from 0 to 4.  
@JMP_A  5                ; The number of the jump table listing is five.  
JMP     A0POINT        ; If ACC = 0, jump to A0POINT  
JMP     A1POINT        ; ACC = 1, jump to A1POINT  
JMP     A2POINT        ; ACC = 2, jump to A2POINT  
JMP     A3POINT        ; ACC = 3, jump to A3POINT  
JMP     A4POINT        ; ACC = 4, jump to A4POINT
```

If the jump table position is from 00FDH to 0101H, the “@JMP\_A” macro will make the jump table to start from 0100h.

## 3.2 DATA MEMORY (RAM)

### 3.2.1 OVERVIEW

The SN8P2710 has internally built-in the data memory up to 128 bytes for storing the general-purpose data.

For SN8P2710

- 128 \* 8-bit general purpose area in bank 0
- 128 \* 8-bit system special register area

The memory is located in bank 0. The bank 0, using the first 128-byte location assigned as general-purpose area, and the remaining 128-byte in bank 0 as system register.

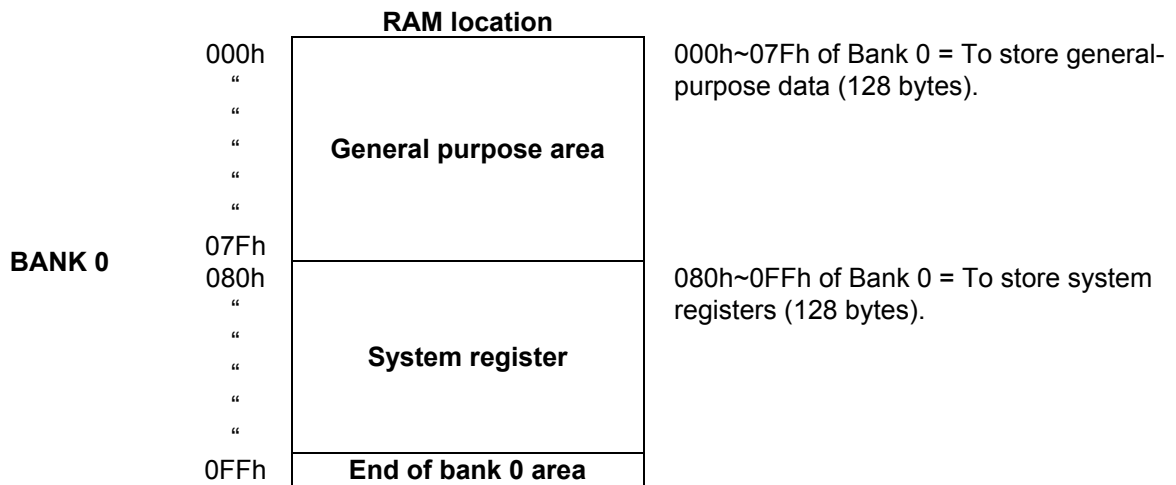

Figure 3-2 RAM Location of SN8P2710

- **Note:** The undefined locations of system register area are logic “high” after executing read instruction “MOV A, M”.

## 3.3 WORKING REGISTERS

The locations 82H to 84H of RAM bank 0 in data memory stores the specially defined registers such as register R, Y, Z, respectively shown in the following table. These registers can use as the general purpose of working buffer and be used to access ROM's and RAM's data. For instance, all of the ROM's table can be looked-up with R, Y and Z registers. The data of RAM memory can be indirectly accessed with Y and Z registers.

	80H	81H	82H	83H	84H	85H	
<b>RAM</b>	-	-	R	Z	Y	-	
	-	-	R/W	R/W	R/W	-	

### 3.3.1 Y, Z REGISTERS

The Y and Z registers are the 8-bit buffers. There are three major functions of these registers. First, Y and Z registers can be used as working registers. Second, these two registers can be used as data pointers for @YZ register. Third, the registers can be address ROM location in order to look-up ROM data.

**Y initial value = XXXX XXXX**

084H	Bit 7	Bit 6	Bit 5	Bit 4	Bit 3	Bit 2	Bit 1	Bit 0
<b>Y</b>	YBIT7	YBIT6	YBIT5	YBIT4	YBIT3	YBIT2	YBIT1	YBIT0
	R/W	R/W	R/W	R/W	R/W	R/W	R/W	R/W

**Z initial value = XXXX XXXX**

083H	Bit 7	Bit 6	Bit 5	Bit 4	Bit 3	Bit 2	Bit 1	Bit 0
<b>Z</b>	ZBIT7	ZBIT6	ZBIT5	ZBIT4	ZBIT3	ZBIT2	ZBIT1	ZBIT0
	R/W	R/W	R/W	R/W	R/W	R/W	R/W	R/W

The @YZ that is data point\_1 index buffer located at address E7H in RAM bank 0. It employs Y and Z registers to addressing RAM location in order to read/write data through ACC. The Lower 4-bit of Y register is pointed to RAM bank number and Z register is pointed to RAM address number, respectively. The higher 4-bit data of Y register is truncated in RAM indirectly access mode.

⇒ **Example: If want to read a data from RAM address 25H of bank 0, it can use indirectly addressing mode to access data as following.**

```
B0MOV    Y, #00H           ; To set RAM bank 0 for Y register
B0MOV    Z, #25H           ; To set location 25H for Z register
B0MOV    A, @YZ            ; To read a data into ACC
```

⇒ **Example: Clear general-purpose data memory area of bank 0 using @YZ register.**

```
MOV      A, #0
B0MOV    Y, A               ; Y = 0, bank 0
MOV      A, #07FH
B0MOV    Z, A               ; Z = 7FH, the last address of the data memory area
```

CLR\_YZ\_BUF:

```
CLR      @YZ               ; Clear @YZ to be zero

DECMS    Z                 ; Z - 1, if Z= 0, finish the routine
JMP      CLR_YZ_BUF        ; Not zero
```

```
CLR      @YZ               ; End of clear general purpose data memory area of bank 0
```

END\_CLR:

Note: Please consult the "LOOK-UP TABLE DESCRIPTION" about Y, Z register look-up table application.



### 3.3.2 R REGISTERS

There are two major functions of the R register. First, R register can be used as working registers. Second, the R registers can be store high-byte data of look-up ROM data. After MOVC instruction executed, the high-byte data of a ROM address will be stored in R register and the low-byte data stored in ACC.

**R initial value = XXXX XXXX**

082H	Bit 7	Bit 6	Bit 5	Bit 4	Bit 3	Bit 2	Bit 1	Bit 0
<b>R</b>	RBIT7	RBIT6	RBIT5	RBIT4	RBIT3	RBIT2	RBIT1	RBIT0
	R/W	R/W	R/W	R/W	R/W	R/W	R/W	R/W

➤ **Note:** Please consult the “LOOK-UP TABLE DESCRIPTION” about R register look-up table application.

## 3.4 PROGRAM FLAG

The PFLAG includes reset flag, low voltage detect flag, carry flag, decimal carry flag (DC) and zero flag (Z). If the result of operating is zero or there is carry, borrow occurrence, then these flags will be set to PFLAG register.

**PFLAG initial value = 00xx,x000**

086H	Bit 7	Bit 6	Bit 5	Bit 4	Bit 3	Bit 2	Bit 1	Bit 0
<b>PFLAG</b>	NT0	NPD	LVD36	LVD24	-	C	DC	Z
	R/W	R/W	R/W	R/W	-	R/W	R/W	R/W

### 3.4.1 RESET FLAG

NT0	NPD	Reset Status
0	0	Watch-dog time out
0	1	Reserved
1	0	Reset by LVD
1	1	Reset by external Reset Pin

### 3.4.2 LVD 2.4V FLAG

LVD24	VDD Status
1	VDD <= 2.4V
0	VDD > 2.4V

**Note:** This bit is only valid when code option LVD=LVD\_M

### 3.4.3 LVD 3.6V FLAG

LVD36	VDD Status
1	VDD <= 3.6V
0	VDD > 3.6V

**Note:** This bit is only valid when code option LVD=LVD\_H

### **3.4.4 CARRY FLAG**

C = 1: If executed arithmetic addition with occurring carry signal or executed arithmetic subtraction without borrowing signal or executed rotation instruction with shifting out logic "1".

C = 0: If executed arithmetic addition without occurring carry signal or executed arithmetic subtraction with borrowing signal or executed rotation instruction with shifting out logic "0".

### **3.4.5 DECIMAL CARRY FLAG**

DC = 1: If executed arithmetic addition with occurring carry signal from low nibble or executed arithmetic subtraction without borrow signal from high nibble.

DC = 0: If executed arithmetic addition without occurring carry signal from low nibble or executed arithmetic subtraction with borrow signal from high nibble.

### **3.4.6 ZERO FLAG**

Z = 1: ACC or arithmetic operation result is zero after executing a instruction. Refer instruction set table for detailed information.

Z = 0: ACC or arithmetic operation result is not zero after executing a instruction. Refer instruction set table for detailed information.

## 3.5 ACCUMULATOR

The ACC is an 8-bits data register responsible for transferring or manipulating data between ALU and data memory. If the result of operating is zero (Z) or there is carry (C or DC) occurrence, then these flags will be set to PFLAG register.

ACC is not in data memory (RAM), so ACC can't be access by "B0MOV" instruction during the instant addressing mode.

### ⇒ Example: Read and write ACC value.

; Read ACC data and store in BUF data memory

```
MOV     BUF, A
.
```

; Write a immediate data into ACC

```
MOV     A, #0FH
.
```

; Write ACC data from BUF data memory

```
MOV     A, BUF
.
```

The ACC value don't store in any interrupt service executed. ACC must be exchanged to another data memory defined by users. Thus, once interrupt occurs, these data must be stored in the data memory based on the user's program as follows.

### ⇒ Example: ACC and working registers protection.

ACCBUF EQU 00H ; ACCBUF is ACC data buffer in bank 0.

INT\_SERVICE:

```

B0XCH  A, ACCBUF ; B0XCH doesn't change C, Z flag
B0MOV  A, PFLAG
B0MOV  PFLAGBUF, A ; Save PFLAG register in a buffer
.
.
B0MOV  A, PFLAGBUF
B0MOV  PFLAG, A ; Restore PFLAG register from buffer
B0XCH  A, ACCBUF ; Re-load ACC

RETI ; Exit interrupt service vector
```

➤ **Notice:** To save and re-load ACC data must be used "B0XCH" instruction, or the PLAGE value maybe modified by ACC.

## 3.6 STACK OPERATIONS

### 3.6.1 OVERVIEW

The stack buffer of SN8P2710 has 8-level high area and each level is 11-bits length. This buffer is designed to save and restore program counter's (PC) data when interrupt service is executed. The STKP register is a pointer designed to point active level in order to save or restore data from stack buffer for kernel circuit. The STKnH and STKnL are the 12-bit stack buffers to store program counter (PC) data.

#### STACK BUFFER

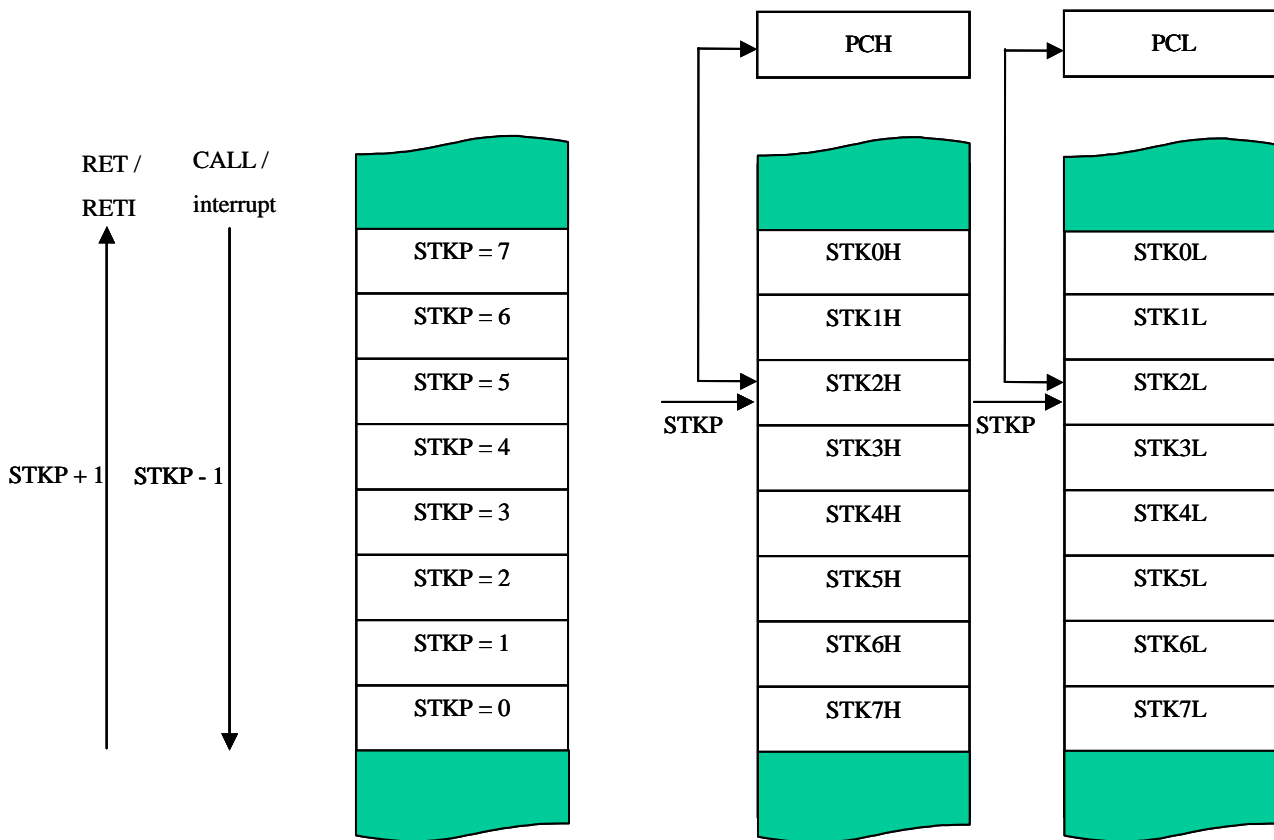

Figure 3-3 Stack Operation

### 3.6.2 STACK REGISTERS

The stack pointer (STKP) is a 4-bit register to store the address used to access the stack buffer, 11-bits data memory (STKnH and STKnL) set aside for temporary storage of stack addresses.

The two stack operations are writing to the top of the stack (Stack-Save) and reading (Stack-Restore) from the top of stack. Stack-Save operation decrements the STKP and the Stack-Restore operation increments one time. That makes the STKP always points to the top address of stack buffer and writes the last program counter value (PC) into the stack buffer.

The program counter (PC) value is stored in the stack buffer before a CALL instruction executed or during interrupt service routine. Stack operation is a LIFO type (Last in and first out). The stack pointer (STKP) and stack buffer (STKnH and STKnL) are located in the system register area bank 0.

**STKP (stack pointer) initial value = 0xxx x111**

0DFH	Bit 7	Bit 6	Bit 5	Bit 4	Bit 3	Bit 2	Bit 1	Bit 0
<b>STKP</b>	GIE	-	-	-	-	STKPB2	STKPB1	STKPB0
	R/W	-	-	-	-	R/W	R/W	R/W

STKPBn: Stack pointer. (n = 0 ~ 3)

GIE: Global interrupt control bit. 0 = disable, 1 = enable. More detail information is in interrupt chapter.

⇒ **Example: Stack pointer (STKP) reset routine.**

```
MOV      A, #00000111B
B0MOV   STKP, A
```

**STKn (stack buffer) initial value = xxxx xxxx xxxx xxxx, STKn = STKnH + STKnL (n = 7 ~ 0)**

0F0H~0FFH	Bit 7	Bit 6	Bit 5	Bit 4	Bit 3	Bit 2	Bit 1	Bit 0
<b>STKnH</b>	-	-	-	-	-	SnPC10	SnPC9	SnPC8
	-	-	-	-	-	R/W	R/W	R/W

0F0H~0FFH	Bit 7	Bit 6	Bit 5	Bit 4	Bit 3	Bit 2	Bit 1	Bit 0
<b>STKnL</b>	SnPC7	SnPC6	SnPC5	SnPC4	SnPC3	SnPC2	SnPC1	SnPC0
	R/W	R/W	R/W	R/W	R/W	R/W	R/W	R/W

STKnH: Store PCH data as interrupt or call executing. The n expressed 0 ~7.

STKnL: Store PCL data as interrupt or call executing. The n expressed 0 ~7.

### 3.6.3 STACK OPERATION EXAMPLE

The two kinds of Stack-Save operations to reference the stack pointer (STKP) and write the program counter contents (PC) into the stack buffer are CALL instruction and interrupt service. Under each condition, the STKP is decremented and points to the next available stack location. The stack buffer stores the program counter about the op-code address. The Stack-Save operation is as following table.

Stack Level	STKP Register			Stack Buffer		Description
	STKPB2	STKPB1	STKPB0	High Byte	Low Byte	
0	1	1	1	STK0H	STK0L	-
1	1	1	0	STK1H	STK1L	-
2	1	0	1	STK2H	STK2L	-
3	1	0	0	STK3H	STK3L	-
4	0	1	1	STK4H	STK4L	-
5	0	1	0	STK5H	STK5L	-
6	0	0	1	STK6H	STK6L	-
7	0	0	0	STK7H	STK7L	-
>8	-	-	-	-	-	<b>Stack Overflow</b>

Table 3-1. STKP, STKnH and STKnL relative of Stack-Save Operation

The RETI instruction is for interrupt service routine. The RET instruction is for CALL instruction. When a Stack-Restore operation occurs, the STKP is incremented and points to the next free stack location. The stack buffer restores the last program counter (PC) to the program counter registers. The Stack-Restore operation is as following table.

Stack Level	STKP Register			Stack Buffer		Description
	STKPB2	STKPB1	STKPB0	High Byte	Low Byte	
7	0	0	0	STK7H	STK7L	-
6	0	0	1	STK6H	STK6L	-
5	0	1	0	STK5H	STK5L	-
4	0	1	1	STK4H	STK4L	-
3	1	0	0	STK3H	STK3L	-
2	1	0	1	STK2H	STK2L	-
1	1	1	0	STK1H	STK1L	-
0	1	1	1	STK0H	STK0L	-

Table 3-2. STKP, STKnH and STKnL relative of Stack-Restore Operation

## 3.7 PROGRAM COUNTER

The program counter (PC) is a 11-bit binary counter separated into the high-byte 3 bits and the low-byte 8 bits. This counter is responsible for pointing a location in order to fetch an instruction for kernel circuit. Normally, the program counter is automatically incremented with each instruction during program execution.

Besides, it can be replaced with specific address by executing CALL or JMP instruction. When JMP or CALL instruction is executed, the destination address will be inserted to bit 0 ~ bit 10.

**PC Initial value = xxxx 0000 0000 0000**

	Bit 15	Bit 14	Bit 13	Bit 12	Bit 11	Bit 10	Bit 9	Bit 8	Bit 7	Bit 6	Bit 5	Bit 4	Bit 3	Bit 2	Bit 1	Bit 0
<b>PC</b>	-	-	-	-	-	0	0	0	0	0	0	0	0	0	0	0
	PCH							PCL								

**PCH Initial value = xxxx x000**

0CFH	Bit 7	Bit 6	Bit 5	Bit 4	Bit 3	Bit 2	Bit 1	Bit 0
<b>PCH</b>	-	-	-	-	-	PC10	PC9	PC8
	-	-	-	-	-	R/W	R/W	R/W

**PCL Initial value = 0000 0000**

0CEH	Bit 7	Bit 6	Bit 5	Bit 4	Bit 3	Bit 2	Bit 1	Bit 0
<b>PCL</b>	PC7	PC6	PC5	PC4	PC3	PC2	PC1	PC0
	R/W	R/W	R/W	R/W	R/W	R/W	R/W	R/W

### 3.7.1 ONE ADDRESS SKIPPING

There are 7 instructions (CMPRS, INCS, INCMS, DECS, DECMS, B0BTS0, B0BTS1) with one address skipping function. If the result of these instructions is matched, the PC will add 2 steps to skip next instruction.

**If the condition of bit test instruction is matched, the PC will add 2 steps to skip next instruction.**

```

      B0BTS1   FC           ; Skip next instruction, if Carry_flag = 1
      JMP      C0STEP      ; Else jump to C0STEP.
C0STEP:      .
              NOP

      B0MOV    A, BUF0     ; Move BUF0 value to ACC.
      B0BTS0   FZ           ; Skip next instruction, if Zero flag = 0.
      JMP      C1STEP      ; Else jump to C1STEP.
C1STEP:      .
              NOP

```

**If the ACC is equal to the immediate data or memory, the PC will add 2 steps to skip next instruction.**

```

      CMPRS    A, #12H     ; Skip next instruction, if ACC = 12H.
      JMP      C0STEP      ; Else jump to C0STEP.
C0STEP:      .
              NOP

```

**If the result after increasing 1 or decreasing 1 is 0xffh (for DECS and DECMS) or 0x00h (for INCS and INCMS) , the PC will add 2 steps to skip next instruction.**

**INCS instruction:**

```

      INCS    BUF0        ; Skip next instruction, if BUF0 = 0X00H.
      JMP      C0STEP      ; Else jump to C0STEP.
C0STEP:      .
              NOP

```

**INCMS instruction:**

```

      INCMS   BUF0        ; Skip next instruction, if BUF0 = 0X00H.
      JMP      C0STEP      ; Else jump to C0STEP.
C0STEP:      .
              NOP

```

**DECS instruction:**

```

      DECS    BUF0        ; Skip next instruction, if BUF0 = 0XFFH.
      JMP      C0STEP      ; Else jump to C0STEP.
C0STEP:      .
              NOP

```

**DECMS instruction:**

```

      DECMS   BUF0        ; Skip next instruction, if BUF0 = 0XFFH.
      JMP      C0STEP      ; Else jump to C0STEP.
C0STEP:      .
              NOP

```



### 3.7.2 MULTI-ADDRESS JUMPING

Users can jump round multi-address by either JMP instruction or ADD M, A instruction (M = PCL) to activate multi-address jumping function. If carry signal occurs after execution of ADD PCL, A, the carry signal will not affect PCH register.

⇒ **Example: If PC = 0323H (PCH = 03H, PCL = 23H)**

```
; PC = 0323H
MOV      A, #28H
B0MOV   PCL, A           ; Jump to address 0328H
.
.
; PC = 0328H
MOV      A, #00H
B0MOV   PCL, A           ; Jump to address 0300H
```

⇒ **Example: If PC = 0323H (PCH = 03H, PCL = 23H)**

```
; PC = 0323H
B0ADD   PCL, A           ; PCL = PCL + ACC, the PCH cannot be changed.
JMP     A0POINT         ; If ACC = 0, jump to A0POINT
JMP     A1POINT         ; ACC = 1, jump to A1POINT
JMP     A2POINT         ; ACC = 2, jump to A2POINT
JMP     A3POINT         ; ACC = 3, jump to A3POINT
.
.
;
```

# 4 ADDRESSING MODE

## 4.1 OVERVIEW

The SN8P2710 provides three addressing modes to access RAM data, including immediate addressing mode, directly addressing mode and indirectly address mode. The main purpose of the three different modes is described in the following:

### 4.1.1 IMMEDIATE ADDRESSING MODE

The immediate addressing mode uses an immediate data to set up the location (MOV A, #I, B0MOV M,#I) in ACC or specific RAM.

#### Immediate addressing mode

```
MOV      A, #12H      ; To set an immediate data 12H into ACC
```

### 4.1.2 DIRECTLY ADDRESSING MODE

The directly addressing mode uses address number to access memory location (MOV A,12H, B0MOV 12H,A).

#### Directly addressing mode

```
B0MOV   A, 12H      ; To get a content of location 12H of bank 0 and save in ACC
```

### 4.1.3 INDIRECTLY ADDRESSING MODE

The indirectly addressing mode is to set up an address in data pointer registers (Y/Z) and uses MOV instruction to read/write data between ACC and @YZ register (MOV A,@YZ, B0MOV @YZ,A).

#### ➔ Example: Indirectly addressing mode with @YZ register

```
CLR     Y           ; To clear Y register to access RAM bank 0.
B0MOV  Z, #12H     ; To set an immediate data 12H into Z register.
B0MOV  A, @YZ      ; Use data pointer @YZ reads a data from RAM location
                   ; 012H into ACC.
```

#### 4.1.4 TO ACCESS DATA in RAM BANK 0

In the RAM bank 0, this area memory can be read/written by these two access methods.

⇒ **Example 1: To use RAM bank0 dedicate instruction (Such as B0xxx instruction).**

```
B0MOV    A, 12H           ; To move content from location 12H of RAM bank 0 to ACC
```

⇒ **Example 2: To use indirectly addressing mode with @YZ register.**

```
CLR      Y               ; To clear Y register for accessing RAM bank 0.  
B0MOV   Z, #12H         ; To set an immediate data 12H into Z register.  
B0MOV   A, @YZ          ; Use data pointer @YZ reads a data from RAM location  
                          ; 012H into ACC.
```

# 5 SYSTEM REGISTER

## 5.1 OVERVIEW

The system special register is located at 80h~FFh. The main purpose of system registers is to control the peripheral hardware of the chip. Using system registers can control I/O ports, ADC, PWM, timers and counters by programming. The Memory map provides an easy and quick reference source for writing application program.

## 5.2 SYSTEM REGISTER ARRANGEMENT (BANK 0)

### 5.2.1 BYTES of SYSTEM REGISTER

SN8P2710

	0	1	2	3	4	5	6	7	8	9	A	B	C	D	E	F
8	-	-	R	Z	Y	-	PFLAG	-	-	-	-	-	-	-	-	-
9	-	-	-	-	-	-	-	-	-	-	-	-	-	-	-	-
A	-	-	-	-	-	-	-	-	-	-	-	-	-	-	P4CON	-
B	DAM	ADM	ADB	ADR	-	-	-	-	-	-	-	-	-	-	-	PEDGE
C	-	-	P2M	-	P4M	P5M	-	-	INTRQ	INTEN	OSCM	-	WDTR	TC0R	PCL	PCH
D	P0	-	P2	-	P4	P5	-	-	T0M	-	TC0M	TC0C	TC1M	TC1C	TC1R	STKP
E	P0UR	-	P2UR	-	P4UR	P5UR	-	@YZ	-	-	-	-	-	-	-	-
F	STK7L	STK7H	STK6L	STK6H	STK5L	STK5H	STK4L	STK4H	STK3L	STK3H	STK2L	STK2H	STK1L	STK1H	STK0L	STK0H

Table 5-1. System Register Arrangement of SN8P2710

#### Description

PFLAG = ROM page and special flag register.

DAM = DAC's mode register.

ADB = ADC's data buffer.

PnM = Port n input/output mode register.

INTRQ = Interrupts' request register.

OSCM = Oscillator mode register.

T0M = Timer/ Counter 0, Timer/ Counter 1 speed selection .

TC1M = Timer/Counter 1 mode register.

TC1C = Timer/Counter 1 counting register.

STKP = Stack pointer buffer.

@HL = RAM HL indirect addressing index pointer.

P4CON= Port 4 configuration setting

R = Working register and ROM lookup data buffer.

Y, Z = Working, @YZ and ROM addressing register.

ADM = ADC's mode register.

ADR = ADC's resolution selects register.

Pn = Port n data buffer.

INTEN = Interrupts' enable register.

PCH, PCL = Program counter.

TC0M = Timer/Counter 0 mode register.

TC0C = Timer/Counter 0 counting register.

TC0R = Timer/Counter 0 auto-reload data buffer.

TC1R = Timer/Counter 1 auto-reload data buffer.

STK0~STK7 = Stack 0 ~ stack 7 buffer.

@YZ = RAM YZ indirect addressing index pointer.

#### ➤ Note:

- All of register names had been declared in SONiX 8-bit MCU assembler.
- One-bit name had been declared in SONiX 8-bit MCU assembler with "F" prefix code.
- It will get logic "H" data, when use instruction to check empty location.
- The low nibble of ADR register is read only.
- "b0bset", "b0bclr", "bset", "bclr" instructions only support "R/W" registers.

## 5.2.2 BITS of SYSTEM REGISTER

**SN8P2710 System register table**

Address	Bit7	Bit6	Bit5	Bit4	Bit3	Bit2	Bit1	Bit0	R/W	Remarks
080H										
081H										
082H	RBIT7	RBIT6	RBIT5	RBIT4	RBIT3	RBIT2	RBIT1	RBIT0	R/W	R
083H	ZBIT7	ZBIT6	ZBIT5	ZBIT4	ZBIT3	ZBIT2	ZBIT1	ZBIT0	R/W	Z
084H	YBIT7	YBIT6	YBIT5	YBIT4	YBIT3	YBIT2	YBIT1	YBIT0	R/W	Y
085H										
086H	NT0	NPD	LVD36	LVD24	-	C	DC	Z	R/W	PFLAG
087H	-	-	-	-	-	-	-	-	-	-
0AEH	P4CON7	P4CON6	P4CON5	P4CON4	P4CON3	P4CON2	P4CON1	P4CON0	W	P4CON
0B0H	DAENB	DAB6	DAB5	DAB4	DAB3	DAB2	DAB1	DAB0	R/W	DAM data register
0B1H	ADENB	ADS	EOC	GCHS	-	CHS2	CHS1	CHS0	R/W	ADM mode register
0B2H	ADB11	ADB10	ADB9	ADB8	ADB7	ADB6	ADB5	ADB4	R	ADB data buffer
0B3H	-	ADCKS1	-	ADCKS0	ADB3	ADB2	ADB1	ADB0	R/W	ADR register
0B4H	-	-	-	-	-	-	-	-	-	-
0B5H	-	-	-	-	-	-	-	-	-	-
0B6H	-	-	-	-	-	-	-	-	-	-
0B8H	-	-	-	-	-	-	-	-	-	-
0BFH	-	-	-	P00G1	P00G0	-	-	-	R/W	PEDGE
0C0H	-	-	-	-	-	-	-	-	-	-
0C1H	-	-	-	-	-	-	-	-	-	-
0C2H	P27M	P26M	P25M	P24M	P23M	P22M	P21M	P20M	R/W	P2M I/O direction
0C3H	-	-	-	-	-	-	-	-	-	-
0C4H	P47M	P46M	P45M	P44M	P43M	P42M	P41M	P40M	R/W	P4M I/O direction
0C5H	-	P56M	P55M	P54M	P53M	P52M	P51M	P50M	R/W	P5M I/O direction
0C8H	-	TC1IRQ	TC0IRQ	-	-	-	P01IRQ	P00IRQ	R/W	INTRQ
0C9H	-	TC1IEN	TC0IEN	-	-	-	P01IEN	P00IEN	R/W	INTEN
0CAH	-	-	-	-	CPUM0	CLKMD	STPHX	-	R/W	OSCM
0CCH	WDTR7	WDTR6	WDTR5	WDTR4	WDTR3	WDTR2	WDTR1	WDTR0	W	WDTR
0CDH	TC0R7	TC0R6	TC0R5	TC0R4	TC0R3	TC0R2	TC0R1	TC0R0	W	TC0R
0CEH	PC7	PC6	PC5	PC4	PC3	PC2	PC1	PC0	R/W	PCL
0CFH	-	-	-	-	-	PC10	PC9	PC8	R/W	PCH
0D0H	-	-	-	-	P03	P02	P01	P00	R	P0 data buffer
0D1H	-	-	-	-	-	-	-	-	-	-
0D2H	P27	P26	P25	P24	P23	P22	P21	P20	R/W	P2 data buffer
0D3H	-	-	-	-	-	-	-	-	-	-
0D4H	P47	P46	P45	P44	P43	P42	P41	P40	R/W	P4 data buffer
0D5H	-	P56	P55	P54	P53	P52	P51	P50	R/W	P5 data buffer
0D8H	-	-	-	-	TC1X8	TC0X8	-	-	R/W	T0M
0D9H	-	-	-	-	-	-	-	-	-	-
0DAH	TC0ENB	TC0rate2	TC0rate1	TC0rate0	TC0CKS	ALOAD0	TC0OUT	PWM0OUT	R/W	TC0M
0DBH	TC0C7	TC0C6	TC0C5	TC0C4	TC0C3	TC0C2	TC0C1	TC0C0	R/W	TC0C
0DCH	TC1ENB	TC1rate2	TC1rate1	TC1rate0	TC1CKS	ALOAD1	TC1OUT	PWM1OUT	R/W	TC1M
0DDH	TC1C7	TC1C6	TC1C5	TC1C4	TC1C3	TC1C2	TC1C1	TC1C0	R/W	TC1C
0DEH	TC1R7	TC1R6	TC1R5	TC1R4	TC1R3	TC1R2	TC1R1	TC1R0	W	TC1R
0DFH	GIE	-	-	-	-	STKPB2	STKPB1	STKPB0	R/W	STKP stack pointer
0E0H	-	-	-	-	-	P02R	P01R	P00R	W	P0UR
0E1H	-	-	-	-	-	-	-	-	-	-
0E2H	P27R	P26R	P25R	P24R	P23R	P22R	P21R	P20R	W	P2UR
0E3H	-	-	-	-	-	-	-	-	-	-
0E4H	P47R	P46R	P45R	P44R	P43R	P42R	P41R	P40R	W	P4UR
0E5H	-	P56R	P54R	P54R	P53R	P52R	P51R	P50R	W	P5UR
0E6H	-	-	-	-	-	-	-	-	-	-
0E7H	@YZ7	@YZ6	@YZ5	@YZ4	@YZ3	@YZ2	@YZ1	@YZ0	R/W	@YZ index pointer
0E9H	-	-	-	-	-	-	-	-	-	-
0F0H	S7PC7	S7PC6	S7PC5	S7PC4	S7PC3	S7PC2	S7PC1	S7PC0	R/W	STK7L
0F1H	-	-	-	-	-	S7PC10	S7PC9	S7PC8	R/W	STK7H
0F2H	S6PC7	S6PC6	S6PC5	S6PC4	S6PC3	S6PC2	S6PC1	S6PC0	R/W	STK6L
0F3H	-	-	-	-	-	S6PC10	S6PC9	S6PC8	R/W	STK6H

Address	Bit7	Bit6	Bit5	Bit4	Bit3	Bit2	Bit1	Bit0	R/W	Remarks
0F4H	S5PC7	S5PC6	S5PC5	S5PC4	S5PC3	S5PC2	S5PC1	S5PC0	R/W	STK5L
0F5H	-	-	-	-	-	S5PC10	S5PC9	S5PC8	R/W	STK5H
0F6H	S4PC7	S4PC6	S4PC5	S4PC4	S4PC3	S4PC2	S4PC1	S4PC0	R/W	STK4L
0F7H	-	-	-	-	-	S4PC10	S4PC9	S4PC8	R/W	STK4H
0F8H	S3PC7	S3PC6	S3PC5	S3PC4	S3PC3	S3PC2	S3PC1	S3PC0	R/W	STK3L
0F9H	-	-	-	-	-	S3PC10	S3PC9	S3PC8	R/W	STK3H
0FAH	S2PC7	S2PC6	S2PC5	S2PC4	S2PC3	S2PC2	S2PC1	S2PC0	R/W	STK2L
0FBH	-	-	-	-	-	S2PC10	S2PC9	S2PC8	R/W	STK2H
0FCH	S1PC7	S1PC6	S1PC5	S1PC4	S1PC3	S1PC2	S1PC1	S1PC0	R/W	STK1L
0FDH	-	-	-	-	-	S1PC10	S1PC9	S1PC8	R/W	STK1H
0FEH	S0PC7	S0PC6	S0PC5	S0PC4	S0PC3	S0PC2	S0PC1	S0PC0	R/W	STK0L
0FFH	-	-	-	-	-	S0PC10	S0PC9	S0PC8	R/W	STK0H

**Table. Bit System Register Table of SN8P2710**

**Note:**

- a). To avoid system error, please be sure to put all the "0" as it indicates in the above table
- b). All of register name had been declared in SONiX 8-bit MCU assembler.
- c). One-bit name had been declared in SONiX 8-bit MCU assembler with "F" prefix code.
- d). "b0bset", "b0bclr", "bset", "bclr" instructions only support "R/W" registers.
- e). For detail description please refer file of "System Register Quick Reference Table"

# 6 RESET

## 6.1 OVERVIEW

The system would be reset in three conditions as following.

- Power on reset
- Watchdog reset
- Brown out reset
- External reset (only supports external reset pin enable situation)

When any reset condition occurs, all system registers keep initial status, program stops and program counter is cleared. After reset status released, the system boots up and program starts to execute from ORG 0.

Finishing any reset sequence needs some time. The system provides complete procedures to make the power on reset successful. For different oscillator types, the reset time is different. That causes the VDD rise rate and start-up time of different oscillator is not fixed. RC type oscillator's start-up time is very short, but the crystal type is longer. Under client terminal application, users have to take care the power on reset time for the master terminal requirement. The reset timing diagram is as following.

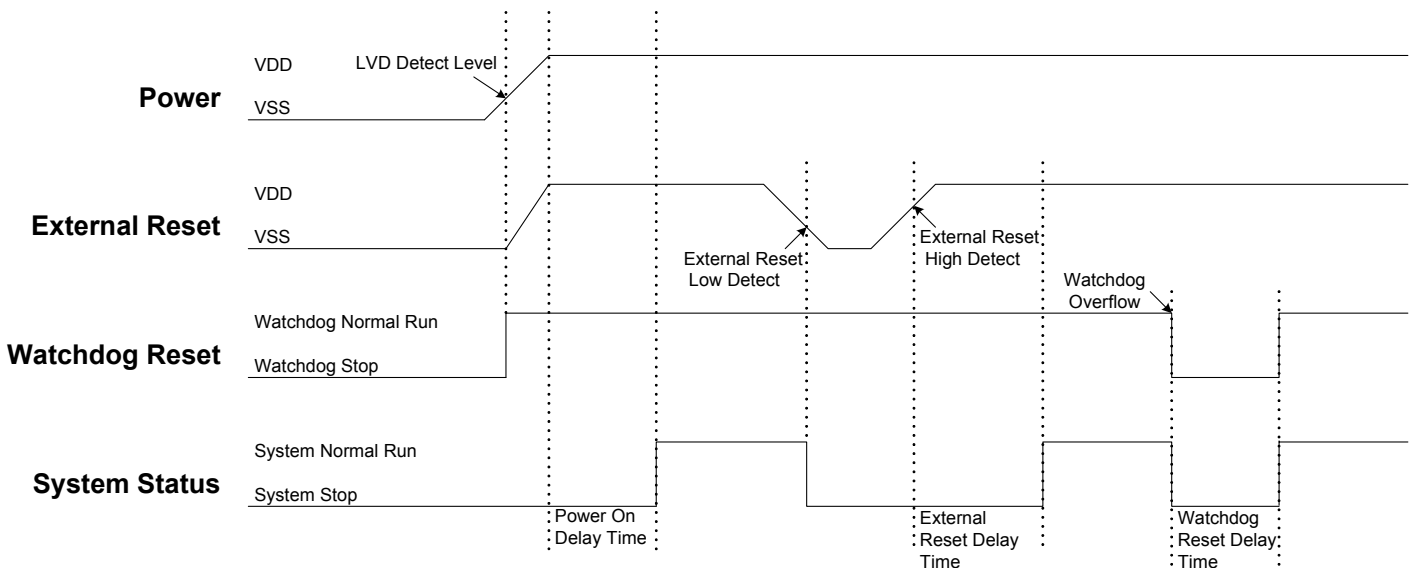

## 6.2 POWER ON RESET

The power on reset depend no LVD operation for most power-up situations. The power supplying to system is a rising curve and needs some time to achieve the normal voltage. Power on reset sequence is as following.

- **Power-up:** System detects the power voltage up and waits for power stable.
- **External reset (only external reset pin enable):** System checks external reset pin status. If external reset pin is not high level, the system keeps reset status and waits external reset pin released.
- **System initialization:** All system registers is set as initial conditions and system is ready.
- **Oscillator warm up:** Oscillator operation is successfully and supply to system clock.
- **Program executing:** Power on sequence is finished and program executes from ORG 0.

## 6.3 WATCHDOG RESET

Watchdog reset is a system protection. In normal condition, system works well and clears watchdog timer by program. Under error condition, system is in unknown situation and watchdog can't be clear by program before watchdog timer overflow. Watchdog timer overflow occurs and the system is reset. After watchdog reset, the system restarts and returns normal mode. Watchdog reset sequence is as following.

- **Watchdog timer status:** System checks watchdog timer overflow status. If watchdog timer overflow occurs, the system is reset.
- **System initialization:** All system registers is set as initial conditions and system is ready.
- **Oscillator warm up:** Oscillator operation is successfully and supply to system clock.
- **Program executing:** Power on sequence is finished and program executes from ORG 0.

Watchdog timer application note is as following.

- Before clearing watchdog timer, check I/O status and check RAM contents can improve system error.
- Don't clear watchdog timer in interrupt vector and interrupt service routine. That can improve main routine fail.
- Clearing watchdog timer program is only at one part of the program. This way is the best structure to enhance the watchdog timer function.

\* **Note:** Please refer to the "WATCHDOG TIMER" about watchdog timer detail information.



## 6.4 BROWN OUT RESET

### 6.4.1 BROWN OUT DESCRIPTION

The brown out reset is a power dropping condition. The power drops from normal voltage to low voltage by external factors (e.g. EFT interference or external loading changed). The brown out reset would make the system not work well or executing program error.

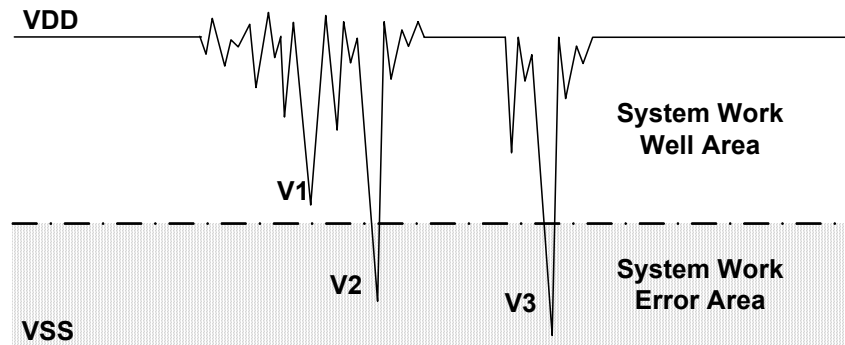

Brown Out Reset Diagram

The power dropping might through the voltage range that's the system dead-band. The dead-band means the power range can't offer the system minimum operation power requirement. The above diagram is a typical brown out reset diagram. There is a serious noise under the VDD, and VDD voltage drops very deep. There is a dotted line to separate the system working area. The above area is the system work well area. The below area is the system work error area called dead-band. V1 doesn't touch the below area and not effect the system operation. But the V2 and V3 is under the below area and may induce the system error occurrence. Let system under dead-band includes some conditions.

#### DC application:

The power source of DC application is usually using battery. When low battery condition and MCU drive any loading, the power drops and keeps in dead-band. Under the situation, the power won't drop deeper and not touch the system reset voltage. That makes the system under dead-band.

#### AC application:

In AC power application, the DC power is regulated from AC power source. This kind of power usually couples with AC noise that makes the DC power dirty. Or the external loading is very heavy, e.g. driving motor. The loading operating induces noise and overlaps with the DC power. VDD drops by the noise, and the system works under unstable power situation.

The power on duration and power down duration are longer in AC application. The system power on sequence protects the power on successful, but the power down situation is like DC low battery condition. When turn off the AC power, the VDD drops slowly and through the dead-band for a while.

## 6.4.2 THE SYSTEM OPERATING VOLTAGE DECSRIPTION

To improve the brown out reset needs to know the system minimum operating voltage which is depend on the system executing rate and power level. Different system executing rates have different system minimum operating voltage. The electrical characteristic section shows the system voltage to executing rate relationship.

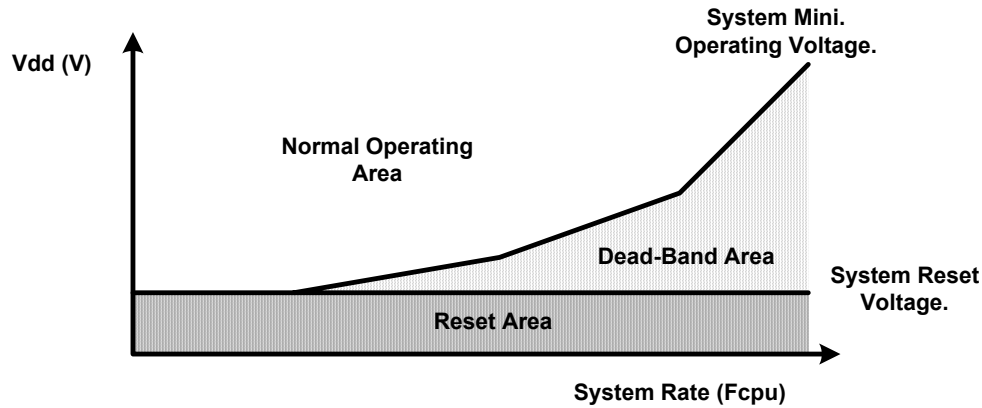

Normally the system operation voltage area is higher than the system reset voltage to VDD, and the reset voltage is decided by LVD detect level. The system minimum operating voltage rises when the system executing rate upper even higher than system reset voltage. The dead-band definition is the system minimum operating voltage above the system reset voltage.

## 6.4.3 BROWN OUT RESET IMPROVEMENT

How to improve the brown reset condition? There are some methods to improve brown out reset as following.

- LVD reset
- Watchdog reset
- Reduce the system executing rate
- External reset circuit. (Zener diode reset circuit, Voltage bias reset circuit, External reset IC)

\* **Note:** 1. The “ Zener diode reset circuit”, “Voltage bias reset circuit” and “External reset IC” can completely improve the brown out reset, DC low battery and AC slow power down conditions.  
2. For AC power application and enhance EFT performance, the system clock is 4MHz/4 (1 mips) and use external reset (“ Zener diode reset circuit”, “Voltage bias reset circuit”, “External reset IC”). The structure can improve noise effective and get good EFT characteristic.

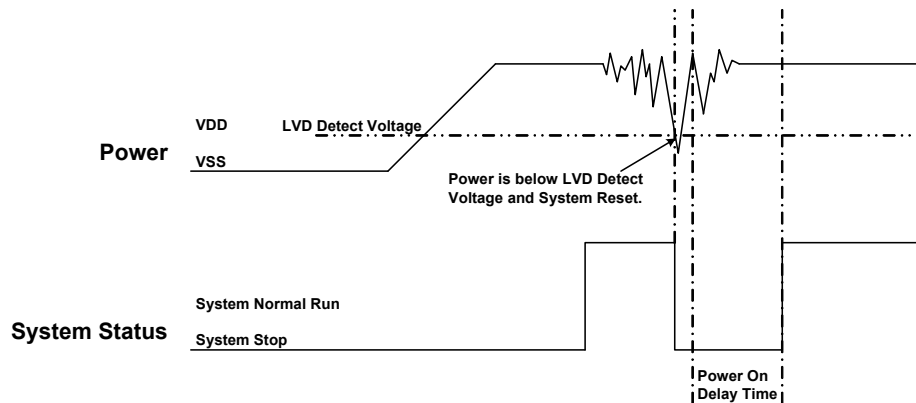
**LVD reset:**

The LVD (low voltage detector) is built-in Sonix 8-bit MCU to be brown out reset protection. When the VDD drops and is below LVD detect voltage, the LVD would be triggered, and the system is reset. The LVD detect level is different by each MCU. The LVD voltage level is a point of voltage and not easy to cover all dead-band range. Using LVD to improve brown out reset is depend on application requirement and environment. If the power variation is very deep, violent and trigger the LVD, the LVD can be the protection. If the power variation can touch the LVD detect level and make system work error, the LVD can't be the protection and need to other reset methods. More detail LVD information is in the electrical characteristic section.

**Watchdog reset:**

The watchdog timer is a protection to make sure the system executes well. Normally the watchdog timer would be clear at one point of program. Don't clear the watchdog timer in several addresses. The system executes normally and the watchdog won't reset system. When the system is under dead-band and the execution error, the watchdog timer can't be clear by program. The watchdog is continuously counting until overflow occurrence. The overflow signal of watchdog timer triggers the system to reset, and the system return to normal mode after reset sequence. This method also can improve brown out reset condition and make sure the system to return normal mode.

If the system reset by watchdog and the power is still in dead-band, the system reset sequence won't be successful and the system stays in reset status until the power return to normal range.

**Reduce the system executing rate:**

If the system rate is fast and the dead-band exists, to reduce the system executing rate can improve the dead-band. The lower system rate is with lower minimum operating voltage. Select the power voltage that's no dead-band issue and find out the mapping system rate. Adjust the system rate to the value and the system exits the dead-band issue. This way needs to modify whole program timing to fit the application requirement.

**External reset circuit:**

The external reset methods also can improve brown out reset and is the complete solution. There are three external reset circuits to improve brown out reset including "Zener diode reset circuit", "Voltage bias reset circuit" and "External reset IC". These three reset structures use external reset signal and control to make sure the MCU be reset under power dropping and under dead-band. The external reset information is described in the next section.

## 6.5 EXTERNAL RESET

External reset function is controlled by “Reset\_Pin” code option. Set the code option as “Reset” option to enable external reset function. External reset pin is Schmitt Trigger structure and low level active. The system is running when reset pin is high level voltage input. The reset pin receives the low voltage and the system is reset. The external reset operation activates in power on and normal running mode. During system power-up, the external reset pin must be high level input, or the system keeps in reset status. External reset sequence is as following.

- **External reset (only external reset pin enable):** System checks external reset pin status. If external reset pin is not high level, the system keeps reset status and waits external reset pin released.
- **System initialization:** All system registers is set as initial conditions and system is ready.
- **Oscillator warm up:** Oscillator operation is successfully and supply to system clock.
- **Program executing:** Power on sequence is finished and program executes from ORG 0.

The external reset can reset the system during power on duration, and good external reset circuit can protect the system to avoid working at unusual power condition, e.g. brown out reset in AC power application...

## 6.6 EXTERNAL RESET CIRCUIT

### 6.6.1 Simply RC Reset Circuit

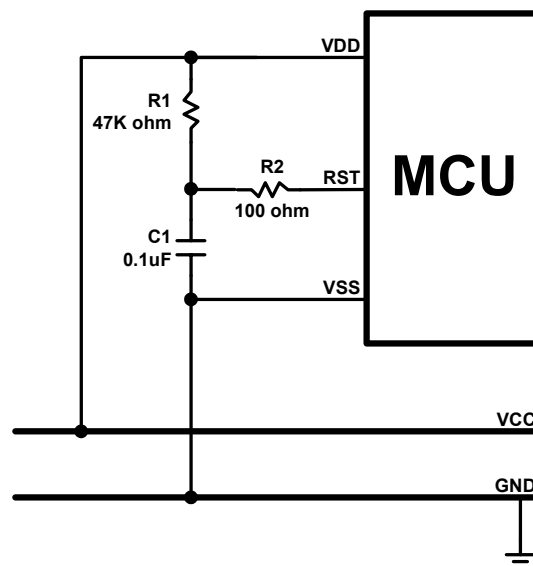

This is the basic reset circuit, and only includes R1 and C1. The RC circuit operation makes a slow rising signal into reset pin as power up. The reset signal is slower than VDD power up timing, and system occurs a power on signal from the timing difference.

\* **Note:** The reset circuit is no any protection against unusual power or brown out reset.

## 6.6.2 Diode & RC Reset Circuit

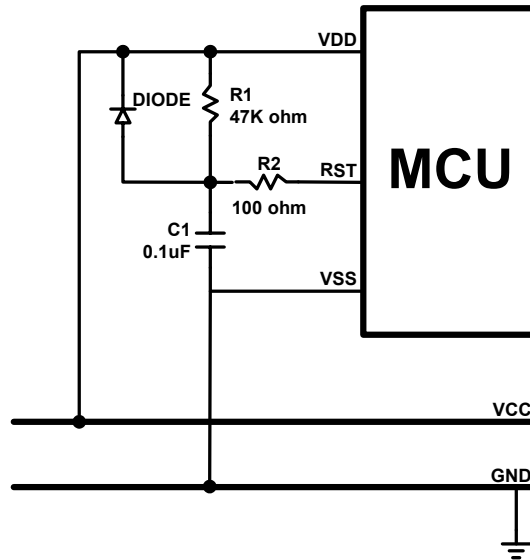

This is the better reset circuit. The R1 and C1 circuit operation is like the simply reset circuit to make a power on signal. The reset circuit has a simply protection against unusual power. The diode offers a power positive path to conduct higher power to VDD. It is can make reset pin voltage level to synchronize with VDD voltage. The structure can improve slight brown out reset condition.

\* **Note:** The R2 100 ohm resistor of “Simply reset circuit” and “Diode & RC reset circuit” is necessary to limit any current flowing into reset pin from external capacitor C in the event of reset pin breakdown due to Electrostatic Discharge (ESD) or Electrical Over-stress (EOS).

## 6.6.3 Zener Diode Reset Circuit

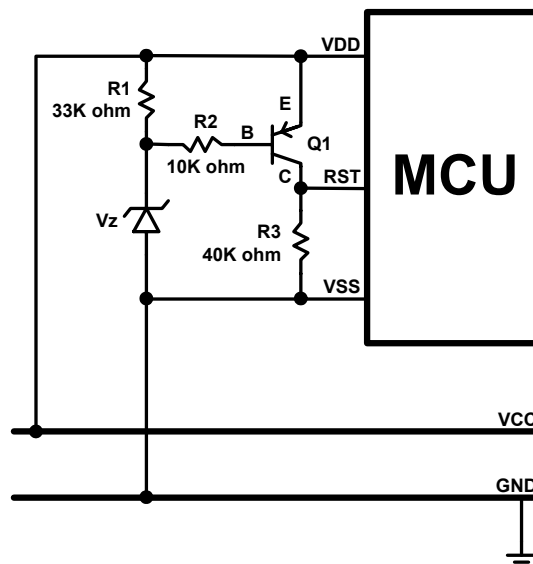

The zener diode reset circuit is a simple low voltage detector and can **improve brown out reset condition completely**. Use zener voltage to be the active level. When VDD voltage level is above “ $V_z + 0.7V$ ”, the C terminal of the PNP transistor outputs high voltage and MCU operates normally. When VDD is below “ $V_z + 0.7V$ ”, the C terminal of the PNP transistor outputs low voltage and MCU is in reset mode. Decide the reset detect voltage by zener specification. Select the right zener voltage to conform the application.

## 6.6.4 Voltage Bias Reset Circuit

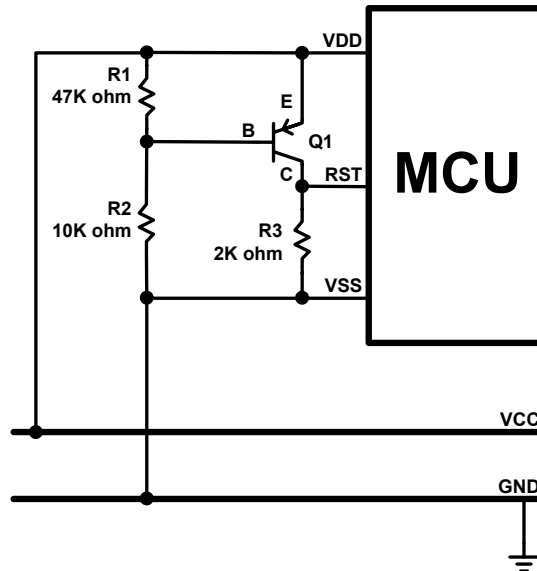

The voltage bias reset circuit is a low cost voltage detector and can **improve brown out reset condition completely**. The operating voltage is not accurate as zener diode reset circuit. Use R1, R2 bias voltage to be the active level. When VDD voltage level is above or equal to  $0.7V \times (R1 + R2) / R1$ , the C terminal of the PNP transistor outputs high voltage and MCU operates normally. When VDD is below  $0.7V \times (R1 + R2) / R1$ , the C terminal of the PNP transistor outputs low voltage and MCU is in reset mode.

Decide the reset detect voltage by R1, R2 resistances. Select the right R1, R2 value to conform the application. In the circuit diagram condition, the MCU's reset pin level varies with VDD voltage variation, and the differential voltage is 0.7V. If the VDD drops and the voltage lower than reset pin detect level, the system would be reset. If want to make the reset active earlier, set the  $R2 > R1$  and the cap between VDD and C terminal voltage is larger than 0.7V. The external reset circuit is with a stable current through R1 and R2. For power consumption issue application, e.g. DC power system, the current must be considered to whole system power consumption.

**\* Note: Under unstable power condition as brown out reset, "Zener diode rest circuit" and "Voltage bias reset circuit" can protects system no any error occurrence as power dropping. When power drops below the reset detect voltage, the system reset would be triggered, and then system executes reset sequence. That makes sure the system work well under unstable power situation.**

### 6.6.5 External Reset IC

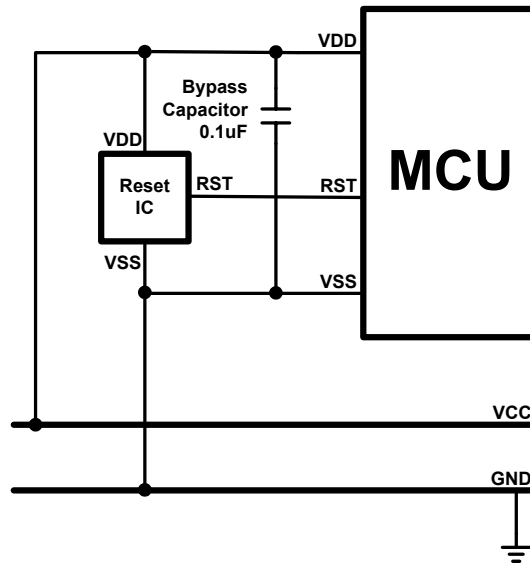

The external reset circuit also use external reset IC to enhance MCU reset performance. This is a high cost and good effect solution. By different application and system requirement to select suitable reset IC. The reset circuit can improve all power variation.

# 7 OSCILLATORS

## 7.1 OVERVIEW

The SN8P2710 highly performs the dual clock micro-controller system. The dual clocks are high-speed clock and low-speed clock. The high-speed clock frequency is supplied through the external oscillator circuit. The low-speed clock frequency is supplied through on-chip RC oscillator circuit.

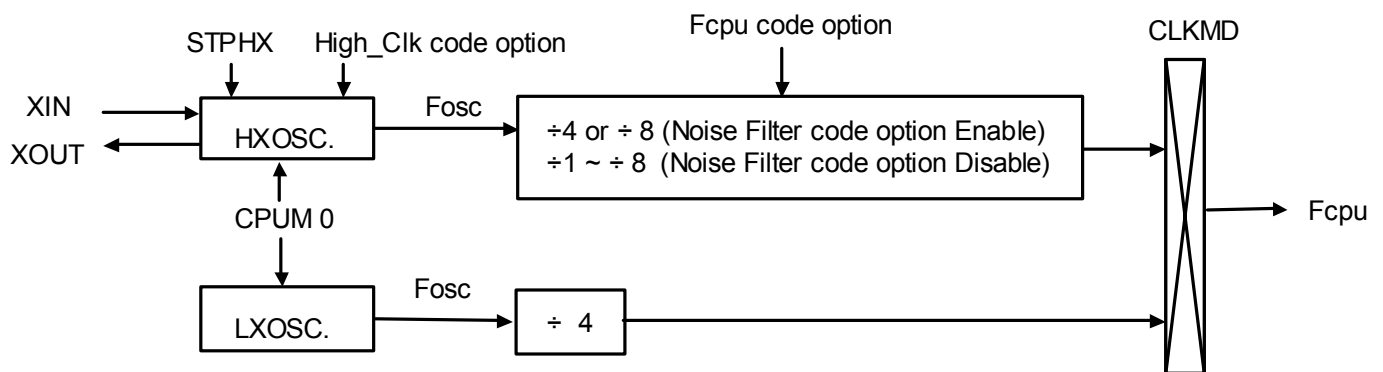

Figure 7-1 System Clock Block Diagram

- Fosc = Fhosc (External high clock) in normal mode
- Fosc = Fosc (Internal low RC clock) in slow mode
- Fosc is system clock, Fcpu is instruction cycle clock
- Fcpu = Fosc/1 ~ Fosc/8 in normal mode
- Fcpu = Fosc/4 in slow mode

The system clock is required by the following peripheral modules:

- ✓ **Timer ( TC0 / TC1 / Watchdog timer)**
- ✓ **PWM output (PWM0, PWM1)**
- ✓ **Buzzer output (TC0OUT, TC1OUT)**
- ✓ **ADC converter**



### 7.1.1 OSCM REGISTER DESCRIPTION

The OSCM register is an oscillator control register. It can control oscillator select, system mode.

**OSCM initial value = xxx0 000x**

0CAH	Bit 7	Bit 6	Bit 5	Bit 4	Bit 3	Bit 2	Bit 1	Bit 0
<b>OSCM</b>	-	-	-	-	CPUM0	CLKMD	STPHX	-
	-	-	-	-	R/W	R/W	R/W	-

Bit [4:3] **CPUM 0**: CPU operating mode control bit.  
 0 = normal mode  
 1 = sleep (power down) mode. Always enter normal mode after wakeup.

Bit 2 **CLKMD**: Select instruction cycle clock (Fcpu) source  
 0 Fcpu came from External high clock (Fhosc). Operation mode is normal mode.  
 1 Fcpu came from Internal low clock (Fosc). Operation mode is slow mode.

Bit1 **STPHX**: Stop High clock control bit.  
 0=High clock free running.  
 1=High clock stop.

### 7.1.2 EXTERNAL HIGH-SPEED OSCILLATOR

The high clock oscillator of SN8P2710 can be configured as four different oscillator types. There are external RC oscillator modes, high crystal/resonator mode (12M code option), standard crystal/resonator mode (4M code option). For different application, the users can select one of suitable oscillator mode by programming “High\_Clk” code option to generate system high-speed clock source after reset.

➔ **Example: Stop external high-speed oscillator.**

B0BSET    FSTPHX                    ; To stop external high-speed oscillator only.

B0BSET    FCPUM0                    ; To stop external high-speed oscillator and internal low-speed  
    ; oscillator called power down mode (sleep mode).

### 7.1.3 HIGH CLOCK OSCILLATOR CODE OPTION

SN8P2710 provide four oscillator modes for different applications. These modes are 4M, 12M and RC. The main purpose is to support different oscillator types and frequencies. High-speed crystal needs more current but the low one doesn't. For crystals, there are three steps to select. User can select oscillator mode from Code Option table before compiling. The table is as follow.

Code Option	Content	Function Description
High_Clk	Ext_RC	Low cost external RC oscillator for high clock oscillator. Output the Fcpu clock from Xout pin.
	12M_X'tal	High speed crystal /resonator (e.g. 12MHz ~ 16MHz) for high clock oscillator.
	4M_X'tal	Middle speed crystal /resonator (e.g. 4MHz ~ 10Mhz) for high clock oscillator.

## 7.1.4 SYSTEM OSCILLATOR CIRCUITS

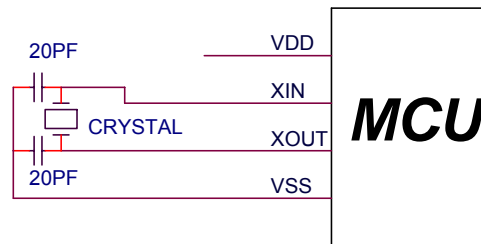

Figure 7-2. Crystal/Ceramic Oscillator

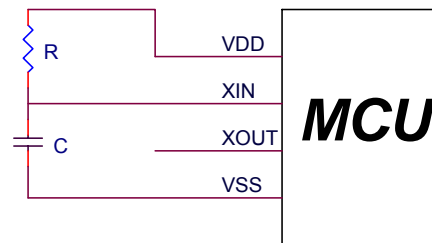

Figure 7-3. RC Oscillator

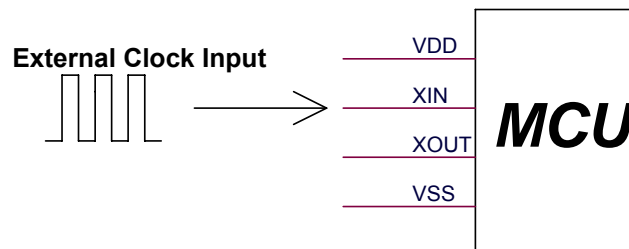

Figure 7-4. External clock input

- **Note1:** The VDD and VSS of external oscillator circuit must be from the micro-controller. Don't connect them from the neighbor power terminal.
- **Note2:** The external clock input mode can select RC type oscillator or crystal type oscillator of the code option and input the external clock into XIN pin.
- **Note3:** The power and ground of external oscillator circuit must be connected from the micro-controller's VDD and VSS. It is necessary to step up the performance of the whole system.

## 7.1.5 External RC Oscillator Frequency Measurement

There is one way to get the Fosc frequency of external RC oscillator by instruction cycle (Fcpu). We can get the Fosc frequency of external RC from the Fcpu frequency. The sub-routine to get Fcpu frequency of external oscillator is as the following.

Example: Fcpu instruction cycle of external oscillator

```
                BOBSET    P2M.0          ; Set P2.0 to be output mode for outputting Fcpu toggle
                ; signal.

@@:
                BOBSET    P2.0           ; Output Fcpu toggle signal in low-speed clock mode.
                BOBCLR    P2.0           ; Measure the Fcpu frequency by oscilloscope.
                JMP       @B
```

## 7.2 INTERNAL LOW-SPEED OSCILLATOR

The internal low-speed oscillator is built in the micro-controller. The low-speed clock's source is a RC type oscillator circuit. The low-speed clock can supply clock for system clock, timer counter, watchdog timer, and so on.

➔ **Example: Stop internal low-speed oscillator.**

```
B0BSET    FCPUM0           ; To stop external high-speed oscillator and internal low-speed
                                ; oscillator called power down mode (sleep mode).
```

➤ **Note: The internal low-speed clock can't be turned off individually. It is controlled by CPUM0 bit of OSCM register.**

The low-speed oscillator uses RC type oscillator circuit. The frequency is affected by the voltage and temperature of the system. In common condition, the frequency of the RC oscillator is about 16KHz at 3V and 32KHz at 5V. The relative between the RC frequency and voltage is as following.

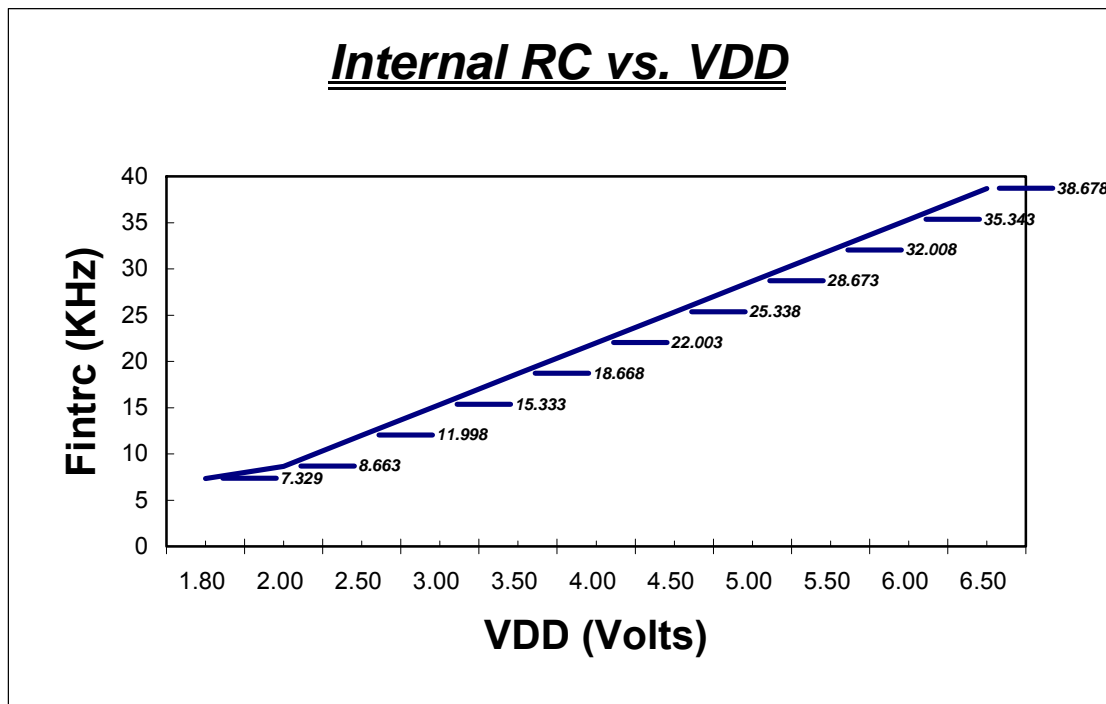

Figure 7-5. Internal RC vs. VDD Diagram

➔ **Example: To measure the internal RC frequency is by instruction cycle (Fcpu). The internal RC frequency is the Fcpu multiplied by 4. So we can get the Fosc frequency of internal RC from the Fcpu frequency.**

```
B0BSET    P2M.0           ; Set P2.0 to be output mode for outputting Fcpu toggle signal.
```

```
B0BSET    FCLKMD          ; Switch the system clock to internal low-speed clock mode.
```

@@:

```
B0BSET    P2.0           ; Output Fcpu toggle signal in low-speed clock mode.
```

```
B0BCLR    P2.0           ; Measure the Fcpu frequency by oscilloscope.
```

```
JMP      @B
```

---

## 7.3 SYSTEM MODE DESCRIPTION

### 7.3.1 OVERVIEW

The chip is featured with low power consumption by switching around three different modes as following. In actual application, the user can adjust the chip's controller to work in these three modes by using OSCM register.

### 7.3.2 NORMAL MODE

In normal mode, the system clock source is external high-speed clock. After power on, the system works under normal mode. All software and hardware are executed and working. In normal mode, system can get into power down mode and slow mode.

### 7.3.3 SLOW MODE

In slow mode, the system clock source is internal low-speed RC clock. To set CLKMD = 1, the system switch to slow mode. In slow mode, the system works as normal mode but the slower clock. The system in slow mode can get into normal mode and power down mode. To set STPHX = 1 to stop the external high-speed oscillator, and then the system consumes less power.

### 7.3.4 POWER DOWN (SLEEP) MODE

The power down mode is also called sleep mode. The chip stops working as sleeping status. The power consumption is very less almost to zero. The power down mode is usually applied to low power consuming system as battery power productions. To set CUPM0 = 1, the system gets into power down mode. The external high-speed and low-speed oscillators are turned off. The system can be waked up by P0 (P0.0, P0.1, P0.2) wakeup trigger signal(P0.0, P0.1, P0.2 level change).

**Note:**

- **Watch\_Dog code option = "Enable"**  
**Stop in power down (sleep) mode.**  
**Enable in normal mode mode.**
- **Watch\_Dog code option = "Always\_ON".**  
**Enable in normal mode and power down (sleep) mode.**

## 7.4 SYSTEM MODE CONTROL

### 7.4.1 SN8P2710 SYSTEM MODE BLOCK DIAGRAM

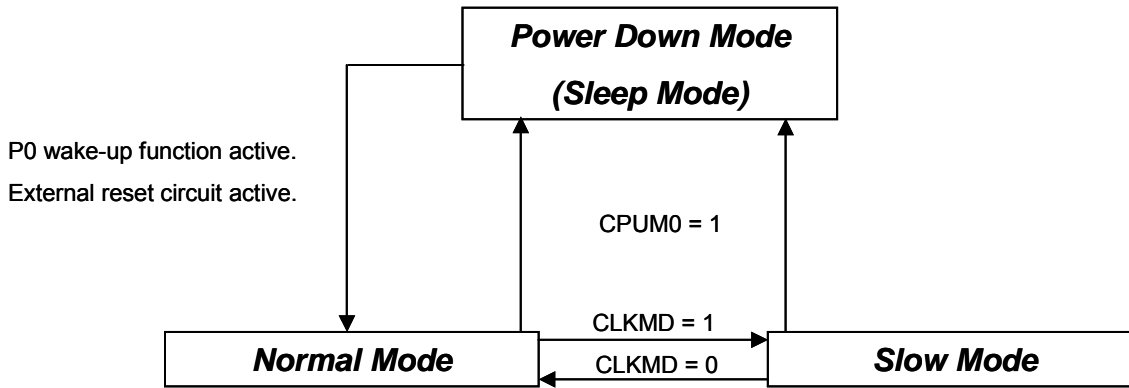

**Figure 7-6. SN8P2710 System Mode Block Diagram**

MODE	NORMAL	SLOW	POWER DOWN (SLEEP)	REMARK
HX osc.	Running	By STPHX	Stop	
LX osc.	Running	Running	Stop	
CPU instruction	Executing	Executing	Stop	
TC0/TC1	*Active	*Active	Inactive	* Active by program
Watchdog timer	Active	Active	By Watchdog code option	
Internal interrupt	All active	All active	All inactive	
External interrupt	All active	All active	All inactive	
Wakeup source	-	-	P0, Reset by RST, LVD, *Watchdog	* Watchdog code option must be "Always_ON"

**Table 7-1. Operating Mode Description**

## 7.4.2 SYSTEM MODE SWITCHING

Switch normal/slow mode to power down (sleep) mode.

CPUM0 = 1

```
B0BSET      FCPUM0      ; Set CPUM0 = 1.
```

During the sleep, only the wakeup pin and reset can wakeup the system back to the normal mode.

Switch normal mode to slow mode.

```
B0BSET      FCLKMD      ;To set CLKMD = 1, Change the system into slow mode
B0BSET      FSTPHX      ;To stop external high-speed oscillator for power saving.
```

➤ **Note: To stop high-speed oscillator is not necessary and user can omit it.**

Switch slow mode to normal mode (The external high-speed oscillator is still running)

```
B0BCLR      FCLKMD      ;To set CLKMD = 0
```

Switch slow mode to normal mode (The external high-speed oscillator stops)

If external high clock stop and program want to switch back normal mode. It is necessary to delay at least 10mS for external clock stable.

```

B0BCLR      FSTPHX      ; Turn on the external high-speed oscillator.
@@:         B0MOV      Z, #27      ; If VDD = 5V, internal RC=32KHz (typical) will delay
            DECMS     Z           ; 0.125ms X 81 = 10.125ms for external clock stable
            JMP      @B
            ;
B0BCLR      FCLKMD      ; Change the system back to the normal mode
```

## 7.5 WAKEUP TIME

### 7.5.1 OVERVIEW

The external high-speed oscillator needs a delay time from stopping to operating. The delay is very necessary and makes the oscillator to work stably. Some conditions during system operating, the external high-speed oscillator often runs and stops. Under these conditions, the delay time for external high-speed oscillator restart is called wakeup time.

There are two conditions need wakeup time. One is power down mode to normal mode. The other one is slow mode to normal mode. For the first case, SN8P2710 provides 4096 oscillator clocks to be the wakeup time. However, in the last case, users need to make the wakeup time by themselves.

### 7.5.2 HARDWARE WAKEUP

When the system is in power down mode (sleep mode), the external high-speed oscillator stops. For wakeup into normal, SN8P2710 provides 4096 external high-speed oscillator clocks to be the wakeup time for warming up the oscillator circuit. After the wakeup time, the system goes into the normal mode. The value of the wakeup time is as following.

$$\text{The Wakeup time} = 1/F_{osc} * 3584 \text{ (sec)} + X'tal \text{ settling time}$$

The x'tal settling time is depended on the x'tal type. Typically, it is about 2~4mS.

➔ **Example: In power down mode (sleep mode), the system is waked up by P0 trigger signal. After the wakeup time, the system goes into normal mode. The wakeup time of P0 wakeup function is as following.**

$$\text{The wakeup time} = 1/F_{osc} * 3584 = 1.001 \text{ ms} \quad (F_{osc} = 3.58\text{MHz})$$

$$\text{The total wakeup time} = 1.001 \text{ ms} + x'tal \text{ settling time}$$

Under power down mode (sleep mode), there are only I/O ports with wakeup function making the system to return normal mode. Port 0.0 and Port 0.1 wakeup function always enables.



# 8 TIMERS COUNTERS

## 8.1 WATCHDOG TIMER (WDT)

This built-in WDT watchdog 4-bit binary up counter designed for monitoring program execution. If the program is operated into the unknown status by noise interference or program dead lock, WDT's overflow signal will reset this chip to restart operation. In normal operation flow, the user must clear watchdog timer before overflow occurs to prevent the program from unexpected system reset. The clock source of watchdog timer (WDT) always comes from internal low speed RC oscillator. The overflow time of WDT is about:

$$1 / ( 16K \div 512 \div 16 ) \sim 0.5s \quad @ 3V$$

$$1 / ( 32K \div 512 \div 16 ) \sim 0.25s \quad @ 5V$$

0CCH	Bit 7	Bit 6	Bit 5	Bit 4	Bit 3	Bit 2	Bit 1	Bit 0
<b>WDTR</b>	WDTR7	WDTR6	WDTR5	WDTR4	WDTR3	WDTR2	WDTR1	WDTR0
Read/Write	R/W	R/W	R/W	R/W	R/W	R/W	R/W	R/W
After reset	-	-	-	-	-	-	-	-

Write WDTR with "0x5A" to clear the Watchdog Timer.

### Note:

- The watchdog timer can be set "Always\_ON", "Enable" and "Disabled" at the code option.
- Watch\_Dog code option = "Enable"  
Stop in power down (sleep) mode.  
Enable in normal mode.
- Watch\_Dog code option = "Always\_ON".  
Enable in normal mode and power down (sleep) mode.

⇒ **Example: An operation of watchdog timer is as following. To clear the watchdog timer counter in the top of the main routine of the program.**

Main:

```

MOV      A,#0x5A
MOV      WDTR,A           ; Clear the watchdog timer counter.
.
CALL     SUB1
CALL     SUB2
.
.
.
JMP     MAIN

```

## 8.2 TIMER COUNTER 0 (TC0)

### 8.2.1 OVERVIEW

The TC0 is an 8-bit binary up timer and event counter for general-purpose timer, buzzer and PWM output. TC0 has an auto re-loadable counter that consists of two parts: an 8-bit reload register (TC0R) into which you write the counter reference value, and an 8-bit counter register (TC0C) whose value is automatically incremented by counter logic.

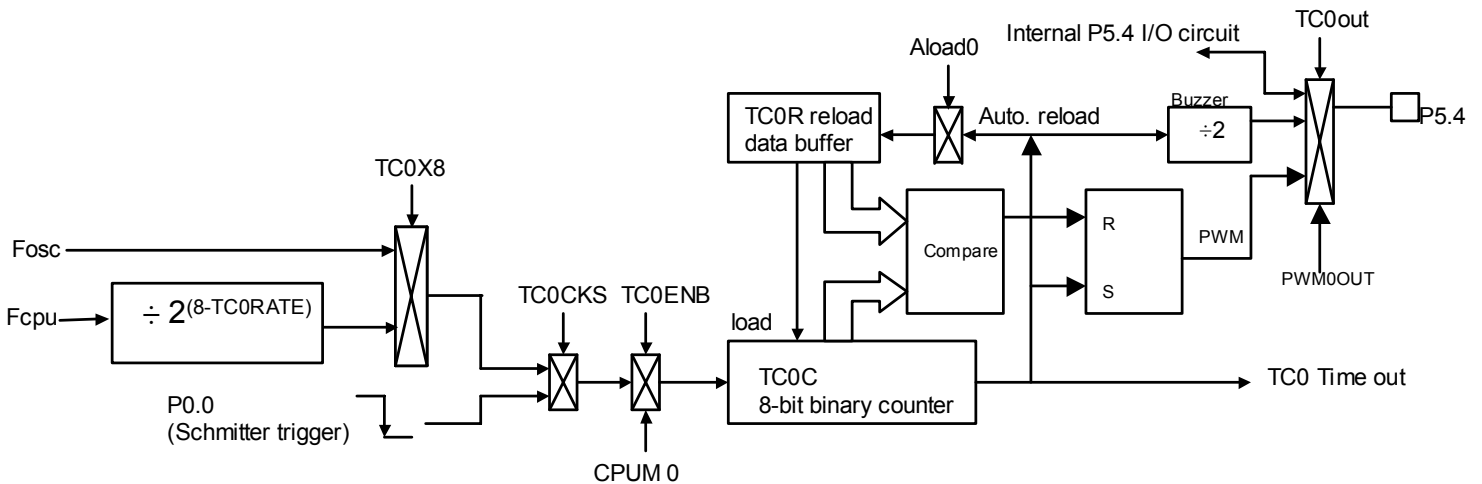

**Figure 8-1. Timer Count TC0 Block Diagram**

The main purposes of the TC0 timer counter is as following.

- **8-bit programmable timer:** Generates interrupts at specific time intervals based on the selected clock frequency.
- **Arbitrary frequency output (Buzzer output):** Outputs selectable clock frequencies to the BZ0 pin (P5.4).
- **PWM function:** PWM output can be generated by the PWM1OUT bit and output to PWM0OUT pin (P5.4).

## 8.2.2 TC0M MODE REGISTER

The TC0M is the timer counter mode register, which is an 8-bit read/write register. By loading different value into the TC0M register, users can modify the timer counter clock frequency dynamically when program executing.

Eight rates for TC0 timer can be selected by TC0RATE0 ~ TC0RATE2 and TC0X8 bits. If TC0X8=1 the TC0 clock will come from Fosc and the range is from Fosc/1 to Fosc/128, if TC0X8=0 (Initial), the range is from Fcpu/2 to Fcpu/256. The TC0M initial value is zero and the rate is Fcpu/256. The bit7 of TC0M named TC0ENB is the control bit to start TC0 timer. The combination of these bits is to determine the TC0 timer frequency.

**T0M initial value = xxxx 00xx**

0D8H	Bit 7	Bit 6	Bit 5	Bit 4	Bit 3	Bit 2	Bit 1	Bit 0
T0M	-	-	-	-	TC1X8	TC0X8		-
	-	-	-	-	R/W	R/W		-

Bit3 **TC1X8**: Multiple TC1 timer speed eight times. Refer TC1M register for detailed information.  
0 = TC1 clock came from Fcpu  
1 = TC1 clock came from Fosc

Bit2 **TC0X8**: Multiple TC0 timer speed eight times. Refer TC0M register for detailed information.  
0 = TC0 clock came from Fcpu  
1 = TC0 clock came from Fosc

**\* Note: Under TC0 event counter mode (TC0CKS=1), TC0X8 bit and TC0RATE are useless.**

**TC0M initial value = 0000 0000**

0DAH	Bit 7	Bit 6	Bit 5	Bit 4	Bit 3	Bit 2	Bit 1	Bit 0
<b>TC0M</b>	TC0ENB	TC0RATE2	TC0RATE1	TC0RATE0	TC0CKS	ALOAD0	TC0OUT	PWM0OUT
	R/W	R/W	R/W	R/W	R/W	R/W	R/W	R/W

Bit 7 **TC0ENB**: TC0 counter enable bit.  
0 = disable  
1 = enable

Bit [6:4] **TC0RATE [2:0]**: TC0 internal clock rate select bits. Only for TC0CKS = 0

TC0Rate	TC0X8=0	TC0X8=1
000	Fcpu/256	Fosc/128
001	Fcpu/128	Fosc/64
010	Fcpu/64	Fosc/32
011	Fcpu/32	Fosc/16
100	Fcpu/16	Fosc/8
101	Fcpu/8	Fosc/4
110	Fcpu/4	Fosc/2
111	Fcpu/2	Fosc/1

Bit 3 **TC0CKS**: TC0 clock source select bit.  
0 = Internal clock source (Fcpu or Fosc)  
1 = External clock source input from P0.0 (INT0) pin.

Bit 2 **ALOAD0**: Auto-reload control bit.  
0 = None auto-reload  
1 = Auto-reload.

Bit 1 **TC0OUT**: TC0 time-out toggle signal output control bit. **Only valid when PWM0OUT = 0**  
0 = Disable TC0OUT signal output and enable P5.4's I/O function,  
1 = Enable TC0OUT signal output and disable P5.4's I/O function.

Bit 0 **PWM0OUT**: PWM output control bit. Refer "PWM Function Description" section for detailed information.  
 0 = Disable the PWM output  
 1 = Enable the PWM output (Auto-disable the TC0OUT function.)

PWM0OUT = 1, TC0X8=0

ALOAD0	TC0OUT	TC0 Overflow boundary	PWM duty range	Max PWM Frequency (Fosc = 16M) (Fcpu = 4M)	Note
0	0	FFh to 00h	0/256 ~ 255/256	7.8125K	Overflow per 256 count
0	1	3Fh to 40h	0/64 ~ 63/64	31.25K	Overflow per 64 count
1	0	1Fh to 20h	0/32 ~ 31/32	62.5K	Overflow per 32 count
1	1	0Fh to 10h	0/16 ~ 15/16	125K	Overflow per 16 count

PWM0OUT = 1, TC0X8=1

ALOAD0	TC0OUT	TC0 Overflow boundary	PWM duty range	Max PWM Frequency (Fosc = 16M) (Fcpu = 4M)	Note
0	0	FFh to 00h	0/256 ~ 255/256	62.5K	Overflow per 256 count
0	1	3Fh to 40h	0/64 ~ 63/64	250K	Overflow per 64 count
1	0	1Fh to 20h	0/32 ~ 31/32	500K	Overflow per 32 count
1	1	0Fh to 10h	0/16 ~ 15/16	1000K	Overflow per 16 count

\* **Note:** When TC0CKS=1, TC0 became an external event counter and TC0RATE is useless. No more P0.0 interrupt request will be raised. (P0.0IRQ will be always 0).

## 8.2.3 TC0C COUNTING REGISTER

TC0C is an 8-bit counter register for the timer counter (TC0). TC0C must be reset whenever the TC0ENB is set "1" to start the timer counter. TC0C is incremented by one with a clock pulse which the frequency is determined by TC0RATE0 ~ TC0RATE2. When TC0C has incremented to "0FFH", it will be cleared to "00H" in next clock and an overflow is generated. Under TC0 interrupt service request (TC0IEN) enable condition, the TC0 interrupt request flag will be set "1" and the system executes the interrupt service routine.

**TC0C initial value = xxxx xxxx**

0DBH	Bit 7	Bit 6	Bit 5	Bit 4	Bit 3	Bit 2	Bit 1	Bit 0
<b>TC0C</b>	TC0C7	TC0C6	TC0C5	TC0C4	TC0C3	TC0C2	TC0C1	TC0C0
	R/W	R/W	R/W	R/W	R/W	R/W	R/W	R/W

The equation of TC0C initial value is as following.

$$\text{TC0C initial value} = 256 - (\text{TC0 interrupt interval time} * \text{input clock})$$

⇒ **Example:** To set 10ms interval time for TC0 interrupt at 3.58MHz high-speed mode. TC0C value (74H) = 256 - (10ms \* fcpu/256)

$$\begin{aligned} \text{TC0C initial value} &= 256 - (\text{TC0 interrupt interval time} * \text{input clock}) \\ &= 256 - (10\text{ms} * 3.58 * 10^6 / 256) \\ &= 256 - (10^{-2} * 3.58 * 10^6 / 256) \\ &= 116 \\ &= 74\text{H} \end{aligned}$$

**TC0\_Counter=8-bit, TC0X8=0**

TC0RATE	TC0CLOCK	High speed mode (fcpu = 3.58MHz / 4)		Low speed mode (fcpu = 32768Hz / 4)	
		Max overflow interval	One step = max/256	Max overflow interval	One step = max/256
000	fcpu/256	73.2 ms	286us	8000 ms	31.25 ms
001	fcpu/128	36.6 ms	143us	4000 ms	15.63 ms
010	fcpu/64	18.3 ms	71.5us	2000 ms	7.8 ms
011	fcpu/32	9.15 ms	35.8us	1000 ms	3.9 ms
100	fcpu/16	4.57 ms	17.9us	500 ms	1.95 ms
101	fcpu/8	2.28 ms	8.94us	250 ms	0.98 ms
110	fcpu/4	1.14 ms	4.47us	125 ms	0.49 ms
111	fcpu/2	0.57 ms	2.23us	62.5 ms	0.24 ms

**TC0\_Counter=6-bit , TC0X8=0**

TC0RATE	TC0CLOCK	High speed mode (fcpu = 3.58MHz / 4)		Low speed mode (fcpu = 32768Hz / 4)	
		Max overflow interval	One step = max/256	Max overflow interval	One step = max/256
000	fcpu/256	18.3 ms	71.5us	2000 ms	7.8 ms
001	fcpu/128	9.15 ms	35.8us	1000 ms	3.9 ms
010	fcpu/64	4.57 ms	17.9us	500 ms	1.95 ms
011	fcpu/32	2.28 ms	8.94us	250 ms	0.98 ms
100	fcpu/16	1.14 ms	4.47us	125 ms	0.49 ms
101	fcpu/8	0.57 ms	2.23us	62.5 ms	0.24 ms
110	fcpu/4	0.285 ms	1.11us	31.25 ms	0.12 ms
111	fcpu/2	0.143 ms	0.56 us	15.63 ms	0.06 ms

**TC0\_Counter=5-bit, TC0X8=0**

TC0RATE	TC0CLOCK	High speed mode (fcpu = 3.58MHz / 4)		Low speed mode (fcpu = 32768Hz / 4)	
		Max overflow interval	One step = max/256	Max overflow interval	One step = max/256
000	fcpu/256	9.15 ms	35.8us	1000 ms	3.9 ms
001	fcpu/128	4.57 ms	17.9us	500 ms	1.95 ms
010	fcpu/64	2.28 ms	8.94us	250 ms	0.98 ms
011	fcpu/32	1.14 ms	4.47us	125 ms	0.49 ms
100	fcpu/16	0.57 ms	2.23us	62.5 ms	0.24 ms
101	fcpu/8	0.285 ms	1.11us	31.25 ms	0.12 ms
110	fcpu/4	0.143 ms	0.56 us	15.63 ms	0.06 ms
111	fcpu/2	71.25 us	0.278 us	7.81 ms	0.03 ms

**TC0\_Counter=4-bit, TC0X8=0**

TC0RATE	TC0CLOCK	High speed mode (fcpu = 3.58MHz / 4)		Low speed mode (fcpu = 32768Hz / 4)	
		Max overflow interval	One step = max/256	Max overflow interval	One step = max/256
000	fcpu/256	4.57 ms	17.9us	500 ms	1.95 ms
001	fcpu/128	2.28 ms	8.94us	250 ms	0.98 ms
010	fcpu/64	1.14 ms	4.47us	125 ms	0.49 ms
011	fcpu/32	0.57 ms	2.23us	62.5 ms	0.24 ms
100	fcpu/16	0.285 ms	1.11us	31.25 ms	0.12 ms
101	fcpu/8	0.143 ms	0.56 us	15.63 ms	0.06 ms
110	fcpu/4	71.25 us	0.278 us	7.81 ms	0.03 ms
111	fcpu/2	35.63 us	0.139 us	3.91 ms	0.015 ms

**Table 8-1. The Timing Table of Timer Count TC0**

## 8.2.4 TC0R AUTO-LOAD REGISTER

TC0R is an 8-bit register for the TC0 auto-reload function. TC0R's value applies to TC0OUT and PWM0OUT functions.. Under TC0OUT application, users must enable and set the TC0R register. The main purpose of TC0R is as following.

- Store the auto-reload value and set into TC0C when the TC0C overflow. (ALOAD0 = 1).
- Store the duty value of PWM0OUT function.

**TC0R initial value = xxxx xxxx**

0CDH	Bit 7	Bit 6	Bit 5	Bit 4	Bit 3	Bit 2	Bit 1	Bit 0
<b>TC0R</b>	TC0R7	TC0R6	TC0R5	TC0R4	TC0R3	TC0R2	TC0R1	TC0R0
	W	W	W	W	W	W	W	W

The equation of TC0R initial value is like TC0C as following.

$$\text{TC0R initial value} = 256 - (\text{TC0 interrupt interval time} * \text{input clock})$$

**Note: The TC0R is write-only register can't be process by INCMS, DECMS instructions.**

## 8.2.5 TC0 TIMER COUNTER OPERATION SEQUENCE

The TC0 timer counter's sequence of operation can be following.

- Set the TC0C initial value to setup the interval time.
- Set the TC0ENB to be "1" to enable TC0 timer counter.
- TC0C is incremented by one with each clock pulse which frequency is corresponding to T0M selection.
- TC0C overflow when TC0C from FFH to 00H.
- When TC0C overflow occur, the TC0IRQ flag is set to be "1" by hardware.
- Execute the interrupt service routine.
- Users reset the TC0C value and resume the TC0 timer operation.

### ⇒ Example: Setup the TC0M and TC0C without auto-reload function.

```

B0BCLR    FTC0IEN    ; To disable TC0 interrupt service
B0BCLR    FTC0ENB    ; To disable TC0 timer
MOV       A,#00H     ;
B0MOV     TC0M,A     ; To set TC0 clock = fcpu / 256
MOV       A,#74H     ; To set TC0C initial value = 74H
B0MOV     TC0C,A     ;(To set TC0 interval = 10 ms)

B0BSET    FTC0IEN    ; To enable TC0 interrupt service
B0BCLR    FTC0IRQ    ; To clear TC0 interrupt request
B0BSET    FTC0ENB    ; To enable TC0 timer

```

### ⇒ Example: Setup the TC0M and TC0C with auto-reload function.

```

B0BCLR    FTC0IEN    ; To disable TC0 interrupt service
B0BCLR    FTC0ENB    ; To disable TC0 timer
MOV       A,#00H     ;
B0MOV     TC0M,A     ; To set TC0 clock = fcpu / 256
MOV       A,#74H     ; To set TC0C initial value = 74H
B0MOV     TC0C,A     ; (To set TC0 interval = 10 ms)
B0MOV     TC0R,A     ; To set TC0R auto-reload register

B0BSET    FTC0IEN    ; To enable TC0 interrupt service
B0BCLR    FTC0IRQ    ; To clear TC0 interrupt request
B0BSET    FTC0ENB    ; To enable TC0 timer
B0BSET    ALOAD0     ; To enable TC0 auto-reload function.

```



⇒ Example: TC0 interrupt service routine without auto-reload function.

```

                                ORG          8          ; Interrupt vector
INT_SERVICE:                    JMP          INT_SERVICE

                                B0XCH         A, ACCBUF   ; B0XCH doesn't change C, Z flag
                                B0MOV         A, PFLAG    ;
                                B0MOV         PFLAGBUF, A   ; Save PFLAG register in a buffer ; Save

                                B0BTS1       FTC0IRQ    ; Check TC0IRQ
                                JMP          EXIT_INT      ; TC0IRQ = 0, exit interrupt vector

                                B0BCLR       FTC0IRQ    ; Reset TC0IRQ
                                MOV          A,#74H      ; Reload TC0C
                                B0MOV         TC0C,A

                                .            .            ; TC0 interrupt service routine
                                .            .
                                JMP          EXIT_INT      ; End of TC0 interrupt service routine and exit interrupt
EXIT_INT:                        .            .            vector

                                .            .
                                .            .
                                B0MOV         A, PFLAGBUF ;
                                B0MOV         PFLAG, A    ; Restore PFLAG register from buffer
                                B0XCH         A, ACCBUF   ; Restore ACC value.

                                RETI          ; Exit interrupt vector

```

⇒ Example: TC0 interrupt service routine with auto-reload.

```

                                ORG          8          ; Interrupt vector
INT_SERVICE:                    JMP          INT_SERVICE

                                B0XCH         A, ACCBUF   ; B0XCH doesn't change C, Z flag
                                B0MOV         A, PFLAG    ;
                                B0MOV         PFLAGBUF, A   ; Save PFLAG register in a buffer

                                B0BTS1       FTC0IRQ    ; Check TC0IRQ
                                JMP          EXIT_INT      ; TC0IRQ = 0, exit interrupt vector

                                B0BCLR       FTC0IRQ    ; Reset TC0IRQ
                                .            .            ; TC0 interrupt service routine
                                .            .
                                JMP          EXIT_INT      ; End of TC0 interrupt service routine and exit interrupt
EXIT_INT:                        .            .            vector

                                .            .
                                .            .
                                B0MOV         A, PFLAG    ;
                                B0MOV         PFLAGBUF, A   ; Save PFLAG register in a buffer
                                B0XCH         A, ACCBUF   ; Restore ACC value.

                                RETI          ; Exit interrupt vector

```

## 8.2.6 TC0 CLOCK FREQUENCY OUTPUT (BUZZER)

TC0 timer counter provides a frequency output function. By setting the TC0 clock frequency, the clock signal is output to P5.4 and the P5.4 general purpose I/O function is auto-disable. The TC0 output signal divides by 2. The TC0 clock has many combinations and easily to make difference frequency. This function applies as buzzer output to output multi-frequency.

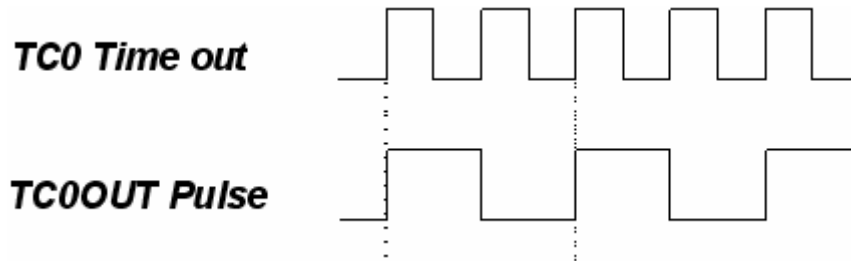

Figure 8-2. The TC0OUT Pulse Frequency

⇒ Example: Setup TC0OUT output from TC0 to TC0OUT (P5.4). The Fcpu is 4MHz. The TC0OUT frequency is 1KHz. Because the TC0OUT signal is divided by 2, set the TC0 clock to 2KHz. The TC0 clock source is from external oscillator clock. TC0 rate is Fcpu/4. The TC0RATE2~TC0RATE1 = 110. TC0C = TC0R = 131, TC0X8=1.

```

MOV      A,#01100000B
B0MOV    TC0M,A          ; Set the TC0 rate to Fcpu/4

MOV      A,#131
B0MOV    TC0C,A          ; Set the auto-reload reference value
B0MOV    TC0R,A
B0BCLR   FTC0X8

B0BSET   FTC0OUT          ; Enable TC0 output to P5.4 and disable P5.4 I/O function
B0BSET   FALOAD0          ; Enable TC0 auto-reload function
B0BSET   FTC0ENB          ; Enable TC0 timer

```

## 8.3 TIMER COUNTER 1 (TC1)

### 8.3.1 OVERVIEW

The timer counter 1 (TC1) is used to generate an interrupt request when a specified time interval has elapsed. TC1 has a auto re-loadable counter that consists of two parts: an 8-bit reload register (TC1R) into which you write the counter reference value, and an 8-bit counter register (TC1C) whose value is automatically incremented by counter logic.

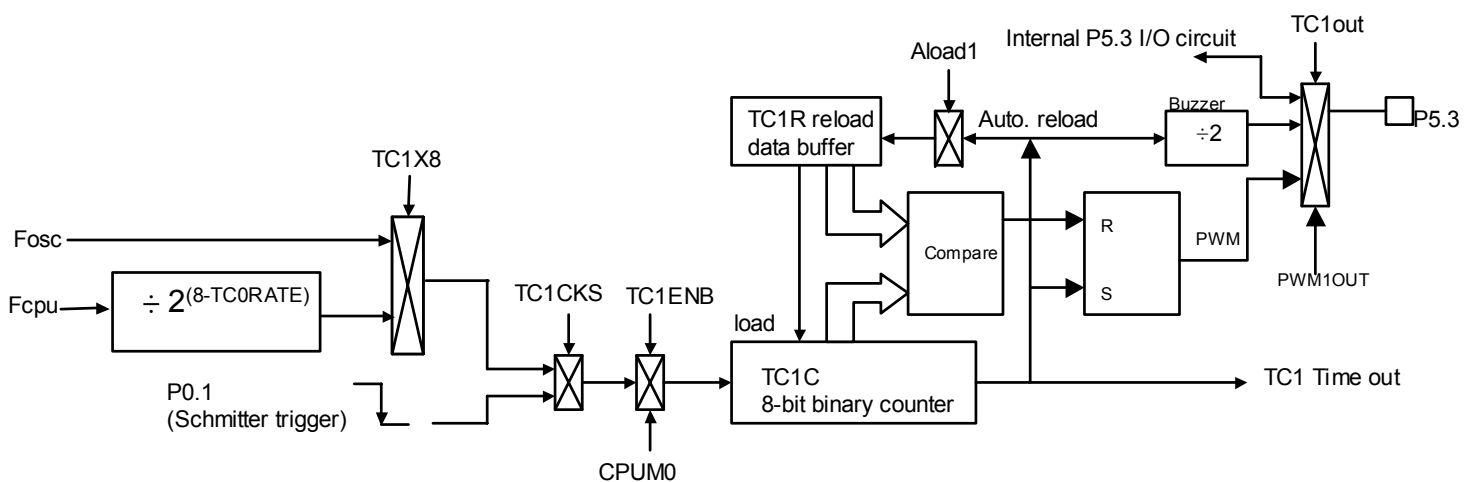

Figure 8-3. Timer Count TC1 Block Diagram

The main purposes of the TC1 timer is as following.

- **8-bit programmable timer:** Generates interrupts at specific time intervals based on the selected clock frequency.
- **Arbitrary frequency output (Buzzer output):** Outputs selectable clock frequencies to the BZ1 pin (P5.3).
- **PWM function:** PWM output can be generated by the PWM1OUT bit and output to PWM1OUT pin (P5.3).

### 8.3.2 TC1M MODE REGISTER

The TC1M is an 8-bit read/write timer mode register. By loading different value into the TC1M register, users can modify the timer clock frequency dynamically as program executing.

Eight rates for TC1 timer can be selected by TC1RATE0 ~ TC1RATE2 bits. If TC1X8=1 the TC1 clock will come from Fosc and the range is from Fosc/1 to Fosc/128. if TC1X8=0 (Initial), the range is from Fcpu(Fosc)/2 to Fcpu(Fosc)/256. The TC1M initial value is zero and the rate is Fcpu/256. The bit7 of TC1M called TC1ENB is the control bit to start TC1 timer. The combination of these bits is to determine the TC1 timer clock frequency and the intervals.

**T0M initial value = xxxx 00xx**

0D8H	Bit 7	Bit 6	Bit 5	Bit 4	Bit 3	Bit 2	Bit 1	Bit 0
T0M	-	-	-	-	TC1X8	TC0X8		-
	-	-	-	-	R/W	R/W		-

Bit3 **TC1X8:** Multiple TC1 timer speed eight times. Refer TC1M register for detailed information.  
0 = TC1 clock came from Fcpu  
1 = TC1 clock came from Fosc

Bit2 **TC0X8:** Multiple TC0 timer speed eight times. Refer TC0M register for detailed information.  
0 = TC0 clock came from Fcpu  
1 = TC0 clock came from Fosc

**\* Note: Under TC1 event counter mode (TC1CKS=1), TC1X8 bit and TC1RATE are useless.**

**TC1M initial value = 0000 0000**

0DCH	Bit 7	Bit 6	Bit 5	Bit 4	Bit 3	Bit 2	Bit 1	Bit 0
<b>TC1M</b>	TC1ENB	TC1RATE2	TC1RATE1	TC1RATE0	TC1CKS	ALOAD1	TC1OUT	PWM1OUT
	R/W	R/W	R/W	R/W	R/W	R/W	R/W	R/W

Bit 7 **TC1ENB:** TC1 counter enable bit.  
0 = disable  
1 = enable

Bit [6:4] **TC1RATE [2:0]:** TC1 internal clock rate select bits. Only for TC1CKS = 0

TC1Rate	TC1X8=0	TC1X8=1
000	Fcpu/256	Fosc/128
001	Fcpu/128	Fosc/64
010	Fcpu/64	Fosc/32
011	Fcpu/32	Fosc/16
100	Fcpu/16	Fosc/8
101	Fcpu/8	Fosc/4
110	Fcpu/4	Fosc/2
111	Fcpu/2	Fosc/1

Bit 3 **TC1CKS:** TC1 clock source select bit.  
0 = Internal clock source (Fcpu/Fosc)  
1 = External clock source input from P0.1 (INT1) pin.

Bit 2 **ALOAD1:** Auto-reload control bit.  
0 = none auto-reload  
1 = auto-reload.

Bit 1 **TC1OUT:** TC1 time-out toggle signal output control bit. **Only valid when PWM1OUT = 0**  
0 = Disable TC1OUT signal output and enable P5.3's I/O function,  
1 = Enable TC1OUT signal output and disable P5.3's I/O function.

Bit 0 **PWM1OUT**: PWM output control bit. Refer "PWM Function Description" section for detailed information.  
 0 = Disable the PWM output  
 1 = Enable the PWM output (Auto-disable the TC1OUT function.)

PWM1OUT = 1, TC1X8=0

ALOAD1	TC1OUT	TC1 Overflow boundary	PWM duty range	Max PWM Frequency (Fosc = 16M) (Fcpu = 4M)	Note
0	0	FFh to 00h	0/256 ~ 255/256	7.8125K	Overflow per 256 count
0	1	3Fh to 40h	0/64 ~ 63/64	31.25K	Overflow per 64 count
1	0	1Fh to 20h	0/32 ~ 31/32	62.5K	Overflow per 32 count
1	1	0Fh to 10h	0/16 ~ 15/16	125K	Overflow per 16 count

PWM0OUT = 1, TC1X8=1

ALOAD0	TC0OUT	TC0 Overflow boundary	PWM duty range	Max PWM Frequency (Fosc = 16M) (Fcpu = 4M)	Note
0	0	FFh to 00h	0/256 ~ 255/256	62.5K	Overflow per 256 count
0	1	3Fh to 40h	0/64 ~ 63/64	250K	Overflow per 64 count
1	0	1Fh to 20h	0/32 ~ 31/32	500K	Overflow per 32 count
1	1	0Fh to 10h	0/16 ~ 15/16	1000K	Overflow per 16 count

\* **Note:** When TC1CKS=1, TC1 became an external event counter and TC1RATE is useless. No more P0.1 interrupt request will be raised. (P0.1IRQ will be always 0).

### 8.3.3 TC1C COUNTING REGISTER

TC1C is an 8-bit counter register for the timer counter (TC1). TC1C must be reset whenever the TC1ENB is set "1" to start the timer. TC1C is incremented by one with a clock pulse which the frequency is determined by TC1RATE0 ~ TC1RATE2. When TC1C has incremented to "0FFH", it will be cleared to "00H" in next clock and an overflow is generated. Under TC1 interrupt service request (TC1IEN) enable condition, the TC1 interrupt request flag will be set "1" and the system executes the interrupt service routine.

**TC1C initial value = xxxx xxxx**

ODDH	Bit 7	Bit 6	Bit 5	Bit 4	Bit 3	Bit 2	Bit 1	Bit 0
<b>TC1C</b>	TC1C7	TC1C6	TC1C5	TC1C4	TC1C3	TC1C2	TC1C1	TC1C0
	R/W	R/W	R/W	R/W	R/W	R/W	R/W	R/W

The interval time of TC1 basic timer table.

The equation of TC1C initial value is as following.

$$\text{TC1C initial value} = 256 - (\text{TC1 interrupt interval time} * \text{input clock})$$

⇒ Example: To set 10ms interval time for TC1 interrupt at 3.58MHz high-speed mode. TC1C value (74H) = 256 - (10ms \* fcpu/256)

$$\begin{aligned} \text{TC1C initial value} &= 256 - (\text{TC1 interrupt interval time} * \text{input clock}) \\ &= 256 - (10\text{ms} * 3.58 * 10^6 / 256) \\ &= 256 - (10^{-2} * 3.58 * 10^6 / 256) \\ &= 116 \\ &= 74\text{H} \end{aligned}$$

**TC1\_Counter=8-bit, TC1X8=0**

TC1RATE	TC1CLOCK	High speed mode (fcpu = 3.58MHz / 4)		Low speed mode (fcpu = 32768Hz / 4)	
		Max overflow interval	One step = max/256	Max overflow interval	One step = max/256
000	fcpu/256	73.2 ms	286us	8000 ms	31.25 ms
001	fcpu/128	36.6 ms	143us	4000 ms	15.63 ms
010	fcpu/64	18.3 ms	71.5us	2000 ms	7.8 ms
011	fcpu/32	9.15 ms	35.8us	1000 ms	3.9 ms
100	fcpu/16	4.57 ms	17.9us	500 ms	1.95 ms
101	fcpu/8	2.28 ms	8.94us	250 ms	0.98 ms
110	fcpu/4	1.14 ms	4.47us	125 ms	0.49 ms
111	fcpu/2	0.57 ms	2.23us	62.5 ms	0.24 ms

**TC1\_Counter=6-bit, TC1X8=0**

TC1RATE	TC1CLOCK	High speed mode (fcpu = 3.58MHz / 4)		Low speed mode (fcpu = 32768Hz / 4)	
		Max overflow interval	One step = max/256	Max overflow interval	One step = max/256
000	fcpu/256	18.3 ms	71.5us	2000 ms	7.8 ms
001	fcpu/128	9.15 ms	35.8us	1000 ms	3.9 ms
010	fcpu/64	4.57 ms	17.9us	500 ms	1.95 ms
011	fcpu/32	2.28 ms	8.94us	250 ms	0.98 ms
100	fcpu/16	1.14 ms	4.47us	125 ms	0.49 ms
101	fcpu/8	0.57 ms	2.23us	62.5 ms	0.24 ms
110	fcpu/4	0.285 ms	1.11us	31.25 ms	0.12 ms
111	fcpu/2	0.143 ms	0.56 us	15.63 ms	0.06 ms

**TC1\_Counter=5-bit, TC1X8=0**

TC1RATE	TC1CLOCK	High speed mode (fcpu = 3.58MHz / 4)		Low speed mode (fcpu = 32768Hz / 4)	
		Max overflow interval	One step = max/256	Max overflow interval	One step = max/256
000	Fcpu/256	9.15 ms	35.8us	1000 ms	3.9 ms
001	Fcpu/128	4.57 ms	17.9us	500 ms	1.95 ms
010	fcpu/64	2.28 ms	8.94us	250 ms	0.98 ms
011	fcpu/32	1.14 ms	4.47us	125 ms	0.49 ms
100	fcpu/16	0.57 ms	2.23us	62.5 ms	0.24 ms
101	fcpu/8	0.285 ms	1.11us	31.25 ms	0.12 ms
110	fcpu/4	0.143 ms	0.56 us	15.63 ms	0.06 ms
111	fcpu/2	71.25 us	0.278 us	7.81 ms	0.03 ms

**TC1\_Counter=4-bit, TC1X8=0**

TC1RATE	TC1CLOCK	High speed mode (fcpu = 3.58MHz / 4)		Low speed mode (fcpu = 32768Hz / 4)	
		Max overflow interval	One step = max/256	Max overflow interval	One step = max/256
000	Fcpu/256	4.57 ms	17.9us	500 ms	1.95 ms
001	Fcpu/128	2.28 ms	8.94us	250 ms	0.98 ms
010	fcpu/64	1.14 ms	4.47us	125 ms	0.49 ms
011	fcpu/32	0.57 ms	2.23us	62.5 ms	0.24 ms
100	fcpu/16	0.285 ms	1.11us	31.25 ms	0.12 ms
101	fcpu/8	0.143 ms	0.56 us	15.63 ms	0.06 ms
110	fcpu/4	71.25 us	0.278 us	7.81 ms	0.03 ms
111	fcpu/2	35.63 us	0.139 us	3.91 ms	0.015 ms

**Table 8-2. The Timing Table of Timer Count TC1**

### 8.3.4 TC1R AUTO-LOAD REGISTER

TC1R is an 8-bit register for the TC1 auto-reload function. TC1R's value applies to TC1OUT and PWM1OUT functions. Under TC1OUT application, users must enable and set the TC1R register. The main purpose of TC1R is as following.

- Store the auto-reload value and set into TC1C when the TC1C overflow. (ALOAD1 = 1).
- Store the duty value of PWM1OUT function.

#### TC1R initial value = xxxx xxxx

0DEH	Bit 7	Bit 6	Bit 5	Bit 4	Bit 3	Bit 2	Bit 1	Bit 0
<b>TC1R</b>	TC1R7	TC1R6	TC1R5	TC1R4	TC1R3	TC1R2	TC1R1	TC1R0
	W	W	W	W	W	W	W	W

The equation of TC1R initial value is like TC1C as following.

$$\text{TC1R initial value} = 256 - (\text{TC1 interrupt interval time} * \text{input clock})$$

**Note:** The TC1R is write-only register can't be process by INCMS, DECMS instructions.



### 8.3.5 TC1 TIMER COUNTER OPERATION SEQUENCE

The TC1 timer's sequence of operation can be following.

- Set the TC1C initial value to setup the interval time.
- Set the TC1ENB to be "1" to enable TC1 timer counter.
- TC1C is incremented by one with each clock pulse which frequency is corresponding to TC1M selection.
- TC1C overflow if TC1C from FFH to 00H.
- When TC1C overflow occur, the TC1IRQ flag is set to be "1" by hardware.
- Execute the interrupt service routine.
- Users reset the TC1C value and resume the TC1 timer operation.

#### ⇒ Example: Setup the TC1M and TC1C without auto-reload function.

```

B0BCLR    FTC1IEN    ; To disable TC1 interrupt service
B0BCLR    FTC1ENB    ; To disable TC1 timer
B0BCLR    FTC1X8     ;
MOV       A,#00H     ;
B0MOV     TC1M,A     ; To set TC1 clock = fcpu / 256
MOV       A,#74H     ; To set TC1C initial value = 74H
B0MOV     TC1C,A     ;(To set TC1 interval = 10 ms)

B0BSET    FTC1IEN    ; To enable TC1 interrupt service
B0BCLR    FTC1IRQ    ; To clear TC1 interrupt request
B0BSET    FTC1ENB    ; To enable TC1 timer

```

#### ⇒ Example: Setup the TC1M and TC1C with auto-reload function.

```

B0BCLR    FTC1IEN    ; To disable TC1 interrupt service
B0BCLR    FTC1ENB    ; To disable TC1 timer
B0BCLR    FTC1X8     ;
MOV       A,#00H     ;
B0MOV     TC1M,A     ; To set TC1 clock = fcpu / 256
MOV       A,#74H     ; To set TC1C initial value = 74H
B0MOV     TC1C,A     ; (To set TC1 interval = 10 ms)
B0MOV     TC1R,A     ; To set TC1R auto-reload register

B0BSET    FTC1IEN    ; To enable TC1 interrupt service
B0BCLR    FTC1IRQ    ; To clear TC1 interrupt request
B0BSET    FTC1ENB    ; To enable TC1 timer
B0BSET    ALOAD1     ; To enable TC1 auto-reload function.

```

⇒ Example: TC1 interrupt service routine without auto-reload function.

```

INT_SERVICE:
    ORG          8          ; Interrupt vector
    JMP          INT_SERVICE

    B0XCH       A, ACCBUF   ; B0XCH doesn't change C, Z flag
    B0MOV       A, PFLAG
    B0MOV       PFLAGBUF, A ; Save PFLAG register in a buffer

    B0BTS1     FTC1IRQ     ; Check TC1IRQ
    JMP         EXIT_INT   ; TC1IRQ = 0, exit interrupt vector

    B0BCLR     FTC1IRQ     ; Reset TC1IRQ
    MOV        A,#74H      ; Reload TC1C
    B0MOV     TC1C,A

    .          .          ; TC1 interrupt service routine
    .          .
    JMP        EXIT_INT   ; End of TC1 interrupt service routine and exit interrupt
                          ; vector

EXIT_INT:
    .          .
    .          .
    B0MOV     A, PFLAGBUF
    B0MOV     PFLAG, A    ; Restore PFLAG register from buffer
    B0XCH     A, ACCBUF   ; Restore ACC value.

    RETI       ; Exit interrupt vector

```

⇒ Example: TC1 interrupt service routine with auto-reload.

```

INT_SERVICE:
    ORG          8          ; Interrupt vector
    JMP          INT_SERVICE

    B0XCH       A, ACCBUF   ; B0XCH doesn't change C, Z flag
    B0MOV       A, PFLAG
    B0MOV       PFLAGBUF, A ; Save PFLAG register in a buffer

    B0BTS1     FTC1IRQ     ; Check TC1IRQ
    JMP         EXIT_INT   ; TC1IRQ = 0, exit interrupt vector

    B0BCLR     FTC1IRQ     ; Reset TC1IRQ
    .          .          ; TC1 interrupt service routine
    .          .
    JMP        EXIT_INT   ; End of TC1 interrupt service routine and exit interrupt
                          ; vector

EXIT_INT:
    .          .
    .          .
    B0MOV     A, PFLAGBUF
    B0MOV     PFLAG, A    ; Restore PFLAG register from buffer
    B0XCH     A, ACCBUF   ; Restore ACC value.

    RETI       ; Exit interrupt vector

```

### 8.3.6 TC1 CLOCK FREQUENCY OUTPUT (BUZZER)

TC1 timer counter provides a frequency output function. By setting the TC1 clock frequency, the clock signal is output to P5.3 and the P5.3 general purpose I/O function is auto-disable. The TC1 output signal divides by 2. The TC1 clock has many combinations and easily to make difference frequency. This function applies as buzzer output to output multi-frequency.

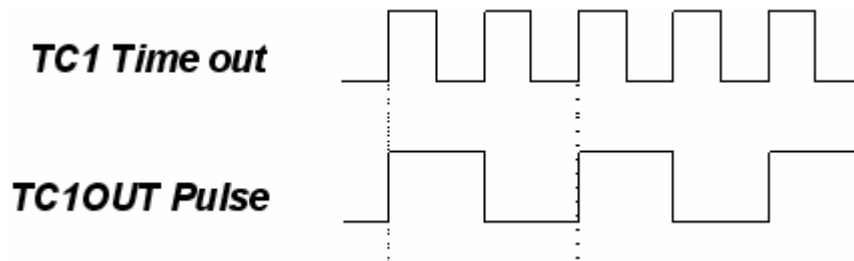

Figure 8-4. The TC1OUT Pulse Frequency

⇒ **Example:** Setup TC1OUT output from TC1 to TC1OUT (P5.3). The Fcpu is 4MHz. The TC1OUT frequency is 1KHz. Because the TC1OUT signal is divided by 2, set the TC1 clock to 2KHz. The TC1 clock source is from external oscillator clock. TC1 rate is Fcpu/4. The TC1RATE2~TC1RATE1 = 110. TC1X8=1, TC1C = TC1R = 131.

```

B0BCLR    FTC1X8          ;
MOV       A,#01100000B
B0MOV     TC1M,A          ; Set the TC1 rate to Fcpu/4

MOV       A,#131          ; Set the auto-reload reference value
B0MOV     TC1C,A
B0MOV     TC1R,A

B0BSET    FTC1OUT        ; Enable TC1 output to P5.3 and disable P5.3 I/O function
B0BSET    FALOAD1        ; Enable TC1 auto-reload function
B0BSET    FTC1ENB        ; Enable TC1 timer

```

➤ **Note:** The TC1OUT frequency table is as TC0OUT frequency table. Please consult TC0OUT frequency table. (Table 7-2~7-5)

## 8.4 PWM FUNCTION DESCRIPTION

### 8.4.1 OVERVIEW

PWM function is generated by TC0/TC1 timer counter and output the PWM signal to PWM0OUT pin (P5.4)/ PWM1OUT pin (P5.3). The 8-bit counter counts modulus 256, from 0-255, inclusive. The value of the 8-bit counter is compared to the contents of the reference register TC0R/TC1R. When the reference register value (TC0R/TC1R) is equal to the counter value TC0C/TC1C, the PWM output goes low. When the counter reaches zero, the PWM output is forced high.

Initial PWM output level is low until the counter value cross boundary (e.g. TC0C changes from FFH back to 00H), the PWM outputs are forced to high level. The pulse width ratio (duty cycle) is defined by TC0R/TC1R registers and the overflow boundary is defined by ALOAD0/ALOAD1 and TC0OUT/TC1OUT bits. PWM output can be held at low level by continuously loading the TC0R/TC1R with 00H. By continuously loading the TC0R with boundary value (e.g. FFH), you can hold the PWM output to high level, except for the last pulse of the clock source, which sends the output low.

**PWM0OUT = 1, TC0X8=0**

ALOAD0 ALOAD1	TC0OUT TC1OUT	TC0 Overflow boundary TC1 Overflow boundary	PWM duty range	Max PWM Frequency (Fcpu = 4M)	Note
0	0	FFh to 00h	0/256 ~ 255/256	7.8125K	Overflow per 256 count
0	1	3Fh to 40h	0/64 ~ 63/64	31.25K	Overflow per 64 count
1	0	1Fh to 20h	0/32 ~ 31/32	62.5K	Overflow per 32 count
1	1	0Fh to 10h	0/16 ~ 15/16	125K	Overflow per 16 count

ALOAD0 ALOAD1	TC0OUT TC1OUT	TC0R TC1R	PWM Duty Range
0	0	00000000 to 11111111	0/256 to 255/256
0	1	XX000000 to XX111111	0/64 to 63/64
1	0	XXX00000 to XXX11111	0/32 to 31/32
1	1	XXXX0000 to XXXX1111	0/16 to 15/16

**Table 8-2. The PWM Duty Cycle Table**

**NOTE:** If PWM0OUT or TC0OUT is enabled, P5.4 mode will be forced as output mode automatically. When PWM0OUT or TC0OUT is disabled, P5.4 mode will be defined by P54M bit.

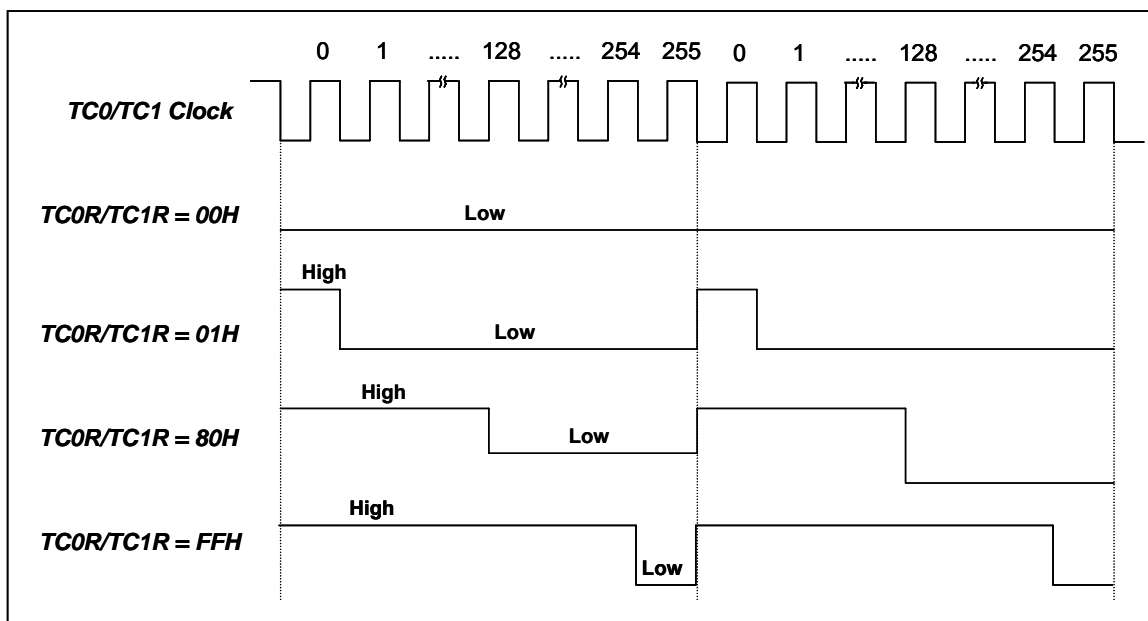

**Figure 8-5 The Output of PWM with different TC0R/TC1R.**

## 8.4.2 PWM PROGRAM DESCRIPTION

➤ **Example:** Setup PWM0 output from TC0 to PWM0OUT (P5.4). The Fcpu is 4MHz. The duty of PWM is 30/256. The PWM frequency is about 1KHz. The PWM clock source is from external oscillator clock. TC0 rate is Fcpu/4. The TC0RATE2~TC0RATE1 = 110. TC0C = TC0R = 30.

```

B0BCLR      FTC0X8      ;
B0BCLR      FTC1X8      ;
MOV         A,#01100000B
B0MOV       TC0M,A      ; Set the TC0 rate to Fcpu/4
B0MOV       TC0M,A      ; Set the TC0 rate to Fcpu/4
MOV         A,#0x00      ;First Time Initial TC0

MOV         A,#30        ; Set the PWM duty to 30/256
B0MOV       TC0R,A

B0BCLR      FTC0OUT     ; Disable TC0OUT function.
B0BSET      FPWM0OUT    ; Enable PWM0 output to P5.4 and disable P5.4 I/O function
B0BSET      FTC0ENB     ; Enable TC0 timer

```

- **Note1:** The TC0R and TC1R are write-only registers. Don't process them using INCMS, DECMS instructions.
- **Note2:** Set TC0C at initial is to make first duty-cycle correct.

➤ **Example:** Modify TC0R/TC1R registers' value.

```

MOV         A, #30H      ; Input a number using B0MOV instruction.
B0MOV       TC0R, A

INCMS      BUF0         ; Get the new TC0R value from the BUF0 buffer defined by
B0MOV       A, BUF0     ; programming.
B0MOV       TC0R, A

```

- **Note3:** That is better to set the TC0C and TC0R value together when PWM0 duty modified. It protects the PWM0 signal no glitch as PWM0 duty changing. That is better to set the TC1C and TC1R value together when PWM1 duty modified. It protects the PWM1 signal no glitch as PWM1 duty changing.
- **Note4:** The TC0OUT function must be set "0" when PWM0 output enable. The TC1OUT function must be set "0" when PWM1 output enable.
- **Note5:** The PWM can work with interrupt request.

### 8.4.3 PWM Duty with TCxR changing

In PWM mode, the system will compare TCxC and TCxR all the time. When  $TCxC < TCxR$ , the PWM will output logic "High", when  $TCxC \geq TCxR$ , the PWM will output logic "Low". If TCxC is changed in certain period, the PWM duty will change in next PWM period.

When TCxR is fixed all the time, the PWM waveform is also the same

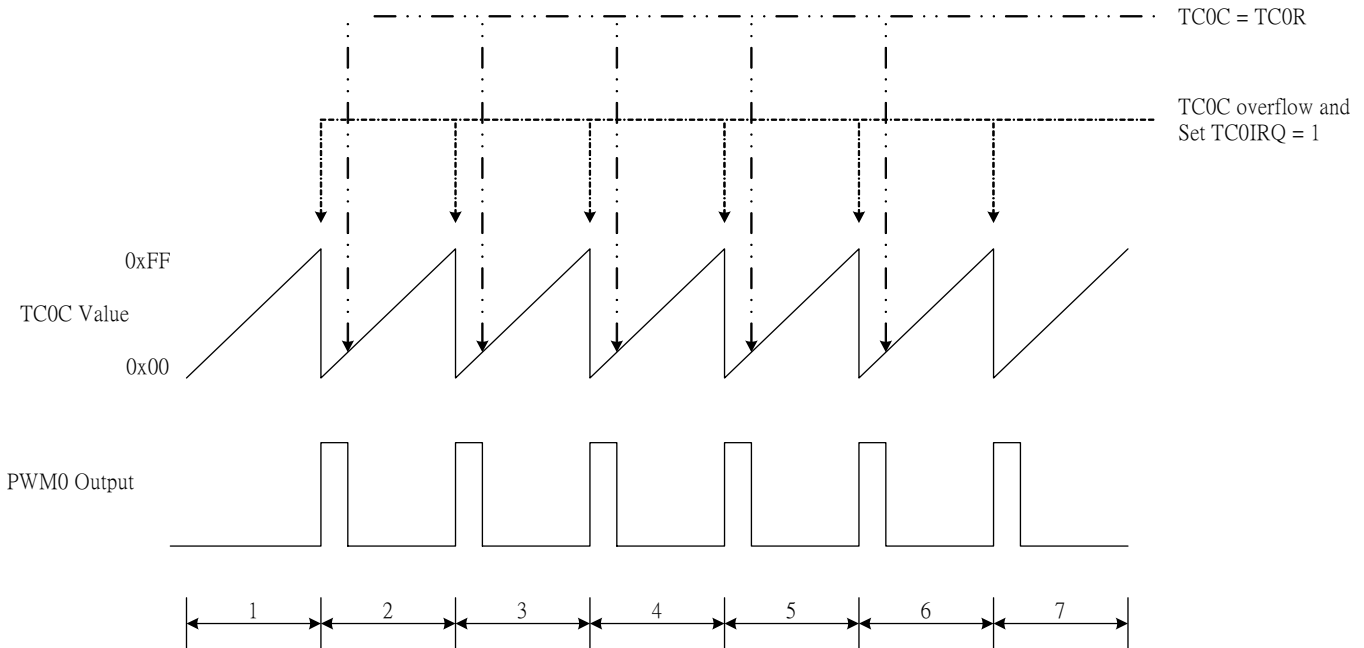

Above diagram is shown the waveform with fixed TCxR. In every TCxC overflow PWM output "High, when  $TCxC \geq TCxR$  PWM output "Low".

When TCxR changing in the program processing, the PWM waveform will become:

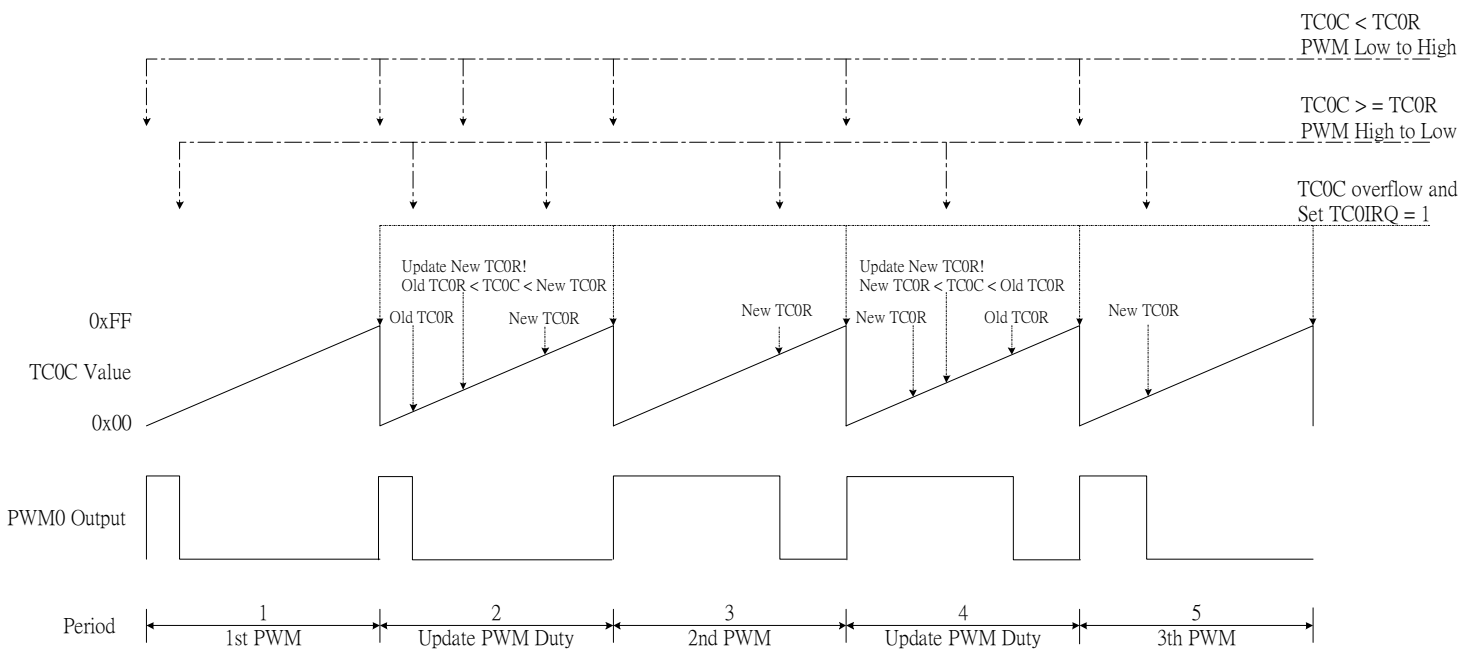

In period 2 and period 4, new Duty (TCxR) is set. However, the PWM still keep the same duty in period 2 and period 4. and the duty changed in next period. By this way, system can avoid the PWM not changing or H/L changing twice in the same cycle and will prevent the unexpected or error operation.

### 8.4.4 TCxIRQ and PWM Duty

In PWM mode, the frequency of TC0IRQ is depended on PWM duty range.

ALOADx	TCxOUT	TCx Overflow boundary	PWM duty range	TCxIRQ Frequency
0	0	FFh to 00h	0/256 ~ 255/256	TCx clock / 256
0	1	3Fh to 40h	0/64 ~ 63/64	TCx clock / 64
1	0	1Fh to 20h	0/32 ~ 31/32	TCx clock / 32
1	1	0Fh to 10h	0/16 ~ 15/16	TCx clock / 16

From following diagram, the TC0IRQ frequency is related with PWM duty.

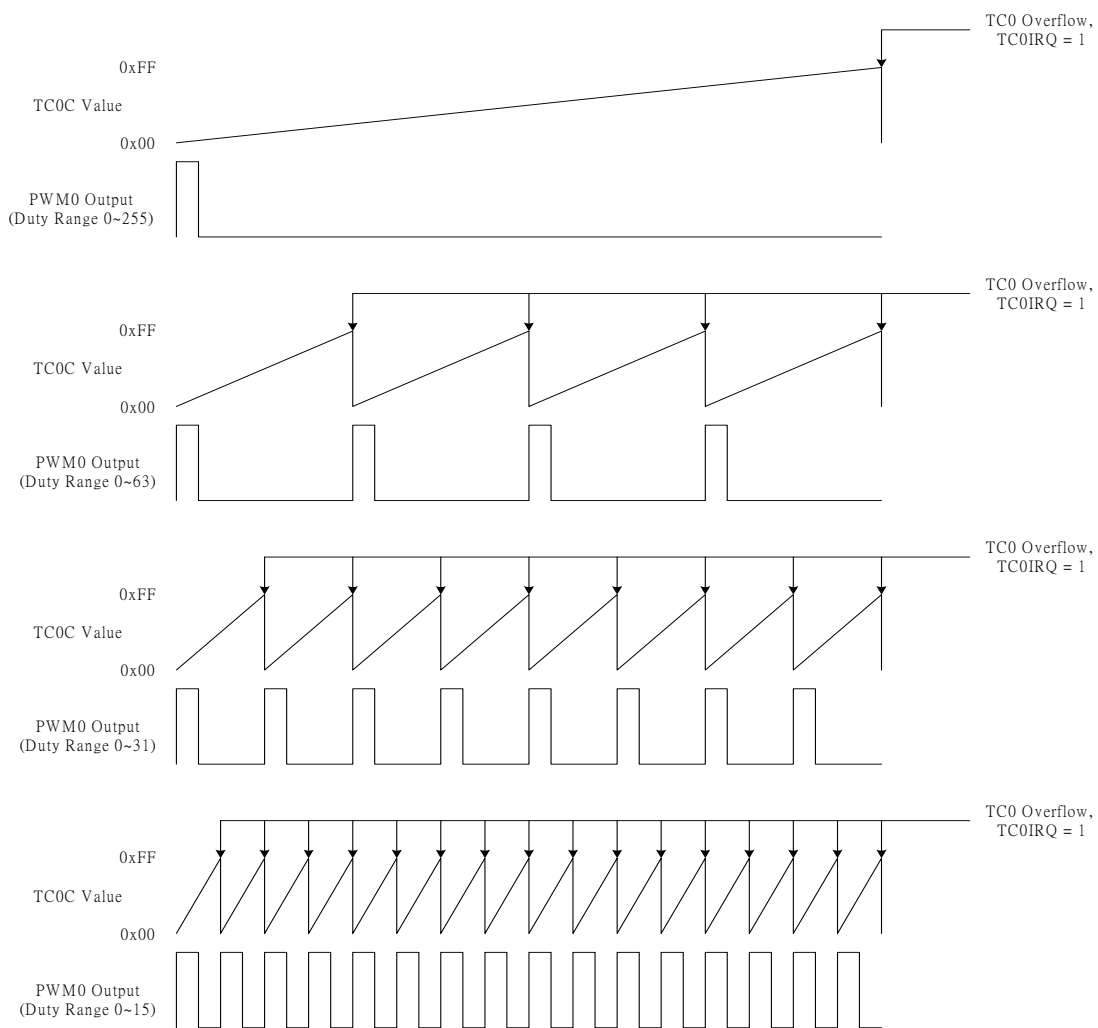

# 9 INTERRUPT

## 9.1 OVERVIEW

The SN8P2710 provides 4 interrupt sources, including two internal interrupts (TC0, TC1) and two external interrupts (INT0, INT1). These external interrupts can wakeup the chip from power down mode to high-speed normal mode. The external clock input pins of INT0/INT1 are shared with P0.0/P0.1 pins. Once interrupt service is executed, the GIE bit in STKP register will clear to "0" for stopping other interrupt request. When interrupt service exits, the GIE bit will set to "1" to accept the next interrupts' request. All of the interrupt request signals are stored in INTRQ register. The user can program the chip to check INTRQ's content for setting executive priority.

➤ **Note: 1.The GIE bit must enable at first and all interrupt operations work.**

## 9.2 INTEN INTERRUPT ENABLE REGISTER

INTEN is the interrupt request control register including two internal interrupts, two external interrupts. One of the register to be set "1" is to enable the interrupt request function. Once of the interrupt occur, the program jump to ORG 8 to execute interrupt service routines. The program exits the interrupt service routine when the returning interrupt service routine instruction (RETI) is executed.

**INTEN initial value = 0000 0000**

0C9H	Bit 7	Bit 6	Bit 5	Bit 4	Bit 3	Bit 2	Bit 1	Bit 0
<b>INTEN</b>	-	TC1IEN	TC0IEN	-	-	-	P01IEN	P00IEN
	-	R/W	R/W	-	-	-	R/W	R/W

Bit 6 **TC1IEN:** Timer interrupt control bit.  
0 = Disable TC1 Interrupt  
1 = Enable TC1 Interrupt

Bit 5 **TC0IEN:** Timer interrupt control bit.  
0 = Disable TC0 Interrupt  
1 = Enable TC10Interrupt

Bit 1 **P01IEN:** External P0.1 interrupt control bit.  
0 = Disable P01 Interrupt  
1 = Enable P01 Interrupt

Bit 0 **P00IEN:** External P0.0 interrupt control bit.  
0 = Disable P00 Interrupt  
1 = Enable P00 Interrupt



## 9.3 INTRQ INTERRUPT REQUEST REGISTER

INTRQ is the interrupt request flag register. The register includes all interrupt request indication flags. Each one of these interrupt request occurs, the bit of the INTRQ register would be set "1". The INTRQ value needs to be clear by programming after detecting the flag. In the interrupt vector of program, users know the any interrupt requests occurring by the register and do the routine corresponding of the interrupt request.

**INTRQ initial value = x00x xx00**

0C8H	Bit 7	Bit 6	Bit 5	Bit 4	Bit 3	Bit 2	Bit 1	Bit 0
<b>INTRQ</b>	-	TC1IRQ	TC0IRQ	-	-	-	P01IRQ	P00IRQ
	-	R/W	R/W	-	-	-	R/W	R/W

Bit 6 **TC1IRQ**: TC1 timer interrupt request controls bit.  
0 = Non request from TC1  
1 = Request from TC1

Bit 5 **TC0IRQ**: TC0 timer interrupt request controls bit.  
0 = Non request from TC0  
1 = Request from TC0

Bit 1 **P01IRQ**: External P0.1 interrupt request bit.  
0 = Non-request from P01  
1 = Request from P01

Bit 0 **P00IRQ**: External P0.0 interrupt request bit.  
0 = Non-request from P00  
1 = Request from P00

## 9.4 P0.0 INTERRUPT TRIGGER EDGE CONTROL REGISTER

**PEDGE initial value = xxx1 0xxx**

0BFH	Bit 7	Bit 6	Bit 5	Bit 4	Bit 3	Bit 2	Bit 1	Bit 0
<b>PEDGE</b>	-	-	-	P00G1	P00G0	-	-	-
	-	-	-	R/W	R/W	-	-	-

Bit [4:3] **P00G [1:0]**: P0.0 interrupt trigger edge control register  
00 = Reserved  
01 = Rising edge  
10 = Falling edge (**Reset default setting**)  
11 = Falling and rising edge both (level change trigger)

## 9.5 INTERRUPT OPERATION DESCRIPTION

SN8P2710 provides 4 interrupts. The operation of the 4 interrupts is as following.

### 9.5.1 GIE GLOBAL INTERRUPT OPERATION

GIE is the global interrupt control bit. All interrupts start work after the GIE = 1. It is necessary for interrupt service request. One of the interrupt requests occurs, and the program counter (PC) points to the interrupt vector (ORG 8) and the stack add 1 level.

**STKP initial value = 0xxx 1111**

0DFH	Bit 7	Bit 6	Bit 5	Bit 4	Bit 3	Bit 2	Bit 1	Bit 0
<b>STKP</b>	GIE	-	-	-	-	STKPB2	STKPB1	STKPB0
	R/W	-	-	-	-	R/W	R/W	R/W

Bit 7      **GIE:** Global interrupt control bit.  
0 = Disable Interrupt function  
1 = Enable Interrupt function

➔ **Example: Set global interrupt control bit (GIE).**

```
BOBSET            FGIE                    ; Enable GIE
```

➤ **Note: The GIE bit must enable and all interrupt operations work.**

## 9.5.2 INT0 (P0.0) INTERRUPT OPERATION

The INT0 is triggered by falling edge. When the INT0 trigger occurs, the P00IRQ will be set to “1” however the P00IEN is enable or disable. If the P00IEN = 1, the trigger event will make the P00IRQ to be “1” and the system enter interrupt vector. If the P00IEN = 0, the trigger event will make the P00IRQ to be “1” but the system will not enter interrupt vector. Users need to care for the operation under multi-interrupt situation.

### ⇒ Example: INT0 interrupt request setup.

```

BOBSET      FP00IEN      ; Enable INT0 interrupt service
BOBCLR      FP00IRQ      ; Clear INT0 interrupt request flag
BOBSET      FGIE         ; Enable GIE

```

### ⇒ Example: INT0 interrupt service routine.

```

ORG          8           ; Interrupt vector
INT_SERVICE:
JMP          INT_SERVICE

BOXCH       A, ACCBUF    ; BOXCH doesn't change C, Z flag
B0MOV      A, PFLAG
B0MOV      PFLAGBUF, A  ; Save PFLAG register in a buffer

B0BTS1     FP00IRQ      ; Check P00IRQ
JMP        EXIT_INT     ; P00IRQ = 0, exit interrupt vector

B0BCLR     FP00IRQ      ; Reset P00IRQ
.          .            ; INT0 interrupt service routine
.          .

EXIT_INT:
B0MOV     A, PFLAGBUF
B0MOV     PFLAG, A      ; Restore PFLAG register from buffer
BOXCH    A, ACCBUF      ; Restore ACC value.

RETI     ; Exit interrupt vector

```

## 9.5.3 INT1 (P0.1) INTERRUPT OPERATION

The INT1 is triggered by falling edge. When the INT1 trigger occurs, the P01IRQ will be set to “1” however the P01IEN is enable or disable. If the P01IEN = 1, the trigger event will make the P01IRQ to be “1” and the system enter interrupt vector. If the P01IEN = 0, the trigger event will make the P01IRQ to be “1” but the system will not enter interrupt vector. Users need to care for the operation under multi-interrupt situation.

### ⇒ Example: INT1 interrupt request setup.

```

BOBSET      FP01IEN      ; Enable INT1 interrupt service
BOBCLR      FP01IRQ      ; Clear INT1 interrupt request flag
BOBSET      FGIE         ; Enable GIE

```

## ⇒ Example: INT1 interrupt service routine.

```

                ORG      8          ; Interrupt vector
                JMP      INT_SERVICE
INT_SERVICE:

                B0XCH    A, ACCBUF  ; B0XCH doesn't change C, Z flag
                B0MOV    A, PFLAG
                B0MOV    PFLAGBUF, A ; Save PFLAG register in a buffer

                B0BTS1   FP01IRQ    ; Check P01IRQ
                JMP      EXIT_INT   ; P01IRQ = 0, exit interrupt vector

                B0BCLR   FP01IRQ    ; Reset P01IRQ
                .        .          ; INT1 interrupt service routine
                .        .

EXIT_INT:

                B0MOV    A, PFLAGBUF ; Restore PFLAG register from buffer
                B0MOV    PFLAG, A
                B0XCH    A, ACCBUF   ; Restore ACC value.

                RETI          ; Exit interrupt vector

```

## 9.5.4 TC0 INTERRUPT OPERATION

When the TC0C counter occurs overflow, the TC0IRQ will be set to “1” no matter the TC0IEN is enable or disable. If the TC0IEN = 1, the trigger event will make the TC0IRQ to be “1” and the system enter interrupt vector. If the TC0IEN = 0, the trigger event will make the TC0IRQ to be “1” but the system will not enter interrupt vector. Users need to care for the operation under multi-interrupt situation.

### ➤ Example: TC0 interrupt request setup.

```

B0BCLR    FTC0IEN    ; Disable TC0 interrupt service
B0BCLR    FTC0ENB    ; Disable TC0 timer
MOV       A, #20H    ;
B0MOV     TC0M, A    ; Set TC0 clock = Fcpu / 64
MOV       A, #74H    ; Set TC0C initial value = 74H
B0MOV     TC0C, A    ; Set TC0 interval = 10 ms

B0BSET    FTC0IEN    ; Enable TC0 interrupt service
B0BCLR    FTC0IRQ    ; Clear TC0 interrupt request flag
B0BSET    FTC0ENB    ; Enable TC0 timer

B0BSET    FGIE       ; Enable GIE

```

### ➤ Example: TC0 interrupt service routine.

```

ORG       8          ; Interrupt vector
JMP      INT_SERVICE

INT_SERVICE:

B0XCH    A, ACCBUF   ; B0XCH doesn't change C, Z flag
B0MOV    A, PFLAG
B0MOV    PFLAGBUF, A ; Save PFLAG register in a buffer

B0BTS1   FTC0IRQ    ; Check TC0IRQ
JMP      EXIT_INT   ; TC0IRQ = 0, exit interrupt vector

B0BCLR   FTC0IRQ    ; Reset TC0IRQ
MOV      A, #74H
B0MOV    TC0C, A    ; Reset TC0C.
.        .          ; TC0 interrupt service routine
.        .

EXIT_INT:
B0MOV    A, PFLAGBUF ; Restore PFLAG register from buffer
B0MOV    PFLAG, A
B0XCH    A, ACCBUF   ; Restore ACC value.

RETI    ; Exit interrupt vector

```

## 9.5.5 TC1 INTERRUPT OPERATION

When the TC1C counter occurs overflow, the TC1IRQ will be set to “1” no matter the TC1IEN is enable or disable. If the TC1IEN = 1, the trigger event will make the TC1IRQ to be “1” and the system enter interrupt vector. If the TC1IEN = 0, the trigger event will make the TC1IRQ to be “1” but the system will not enter interrupt vector. Users need to care for the operation under multi-interrupt situation.

### ➤ Example: TC1 interrupt request setup.

```

B0BCLR    FTC1IEN    ; Disable TC1 interrupt service
B0BCLR    FT C1ENB   ; Disable TC1 timer
MOV       A, #20H    ;
B0MOV     TC1M, A    ; Set TC1 clock = Fcpu / 64
MOV       A, #74H    ; Set TC1C initial value = 74H
B0MOV     TC1C, A    ; Set TC1 interval = 10 ms

B0BSET    FTC1IEN    ; Enable TC1 interrupt service
B0BCLR    FTC1IRQ    ; Clear TC1 interrupt request flag
B0BSET    FTC1ENB    ; Enable TC1 timer

B0BSET    FGIE       ; Enable GIE

```

### ➤ Example: TC1 interrupt service routine.

```

ORG       8          ; Interrupt vector
JMP      INT_SERVICE
INT_SERVICE:

B0XCH    A, ACCBUF   ; B0XCH doesn't change C, Z flag
B0MOV    A, PFLAG
B0MOV    PFLAGBUF, A ; Save PFLAG register in a buffer

B0BTS1   FTC1IRQ    ; Check TC1IRQ
JMP      EXIT_INT   ; TC1IRQ = 0, exit interrupt vector

B0BCLR   FTC1IRQ    ; Reset TC1IRQ
MOV      A, #74H
B0MOV    TC1C, A    ; Reset TC1C.
.        .          ; TC1 interrupt service routine
.        .

EXIT_INT:
B0MOV    A, PFLAGBUF ; Restore PFLAG register from buffer
B0MOV    PFLAG, A
B0XCH    A, ACCBUF   ; Restore ACC value.

RETI     ; Exit interrupt vector

```

## 9.5.6 MULTI-INTERRUPT OPERATION

In most conditions, the software designer uses more than one interrupt request. Processing multi-interrupt request needs to set the priority of these interrupt requests. The IRQ flags of the 4 interrupt are controlled by the interrupt event occurring. But the IRQ flag set doesn't mean the system to execute the interrupt vector. The IRQ flags can be triggered by the events without interrupt enable. Just only any the event occurs and the IRQ will be logic "1". The IRQ and its trigger event relationship is as the below table.

<b>Interrupt Name</b>	<b>Trigger Event Description</b>
P00IRQ	P0.0 trigger. Falling edge.
P01IRQ	P0.1 trigger. Falling edge.
TC0IRQ	TC0C overflow.
TC1IRQ	TC1C overflow.

There are two things need to do for multi-interrupt. One is to make a good priority for these interrupt requests. Two is using IEN and IRQ flags to decide executing interrupt service routine or not. Users have to check interrupt control bit and interrupt request flag in interrupt vector. There is a simple routine as following.

⇒ Example: How does users check the interrupt request in multi-interrupt situation?

```

ORG      8          ; Interrupt vector
NOP
BOXCH    A, ACCBUF  ; BOXCH doesn't change C, Z flag
B0MOV    A, PFLAG
B0MOV    PFLAGBUF, A ; Save PFLAG register in a buffer
INTP00CHK:
B0BTS1   FP00IEN   ; Check INT0 interrupt request
JMP      INTP01CHK ; Check P00IEN
B0BTS0   FP00IRQ   ; Check P00IRQ
JMP      INTP00    ; Jump to INT0 interrupt service routine
INTP01CHK:
B0BTS1   FP01IEN   ; Check INT1 interrupt request
JMP      INTTC0CHK ; Check P01IEN
B0BTS0   FP01IRQ   ; Check P01IRQ
JMP      INTP01    ; Jump to INT1 interrupt service routine
INTTC0CHK:
B0BTS1   FTC0IEN   ; Check TC0 interrupt request
JMP      INTTC1CHK ; Check TC0IEN
B0BTS0   FTC0IRQ   ; Check TC0IRQ
JMP      INTTC0    ; Jump to TC0 interrupt service routine
INTTC1CHK:
B0BTS1   FTC1IEN   ; Check TC1 interrupt request
JMP      INT_EXIT  ; Check TC1IEN
B0BTS0   FTC1IRQ   ; Check TC1IRQ
JMP      INTTC1    ; Jump to TC1 interrupt service routine
INT_EXIT:
B0MOV    A, PFLAGBUF ; Restore PFLAG register from buffer
B0MOV    PFLAG, A    ; Restore ACC value.
BOXCH    A, ACCBUF
RETI     ; Exit interrupt vector

```



# 10 I/O PORT

## 10.1 OVERVIEW

The SN8P2710 provides up to four ports for users' application, consisting of one input only port (P0), three I/O ports (P2, P4, P5). The direction of I/O port is selected by PnM register and register PnUR is defined for user setting pull-up register. After the system resets, all ports work as input function without pull-up resistors.

### Port 0.1 and P0.2 structure:

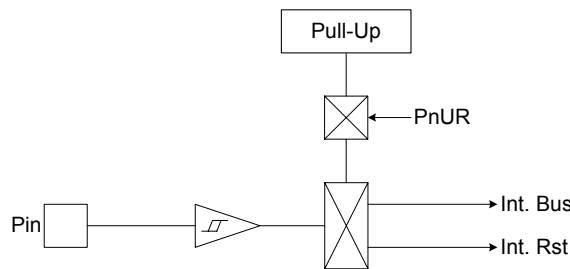

### Port 0.3 structure:

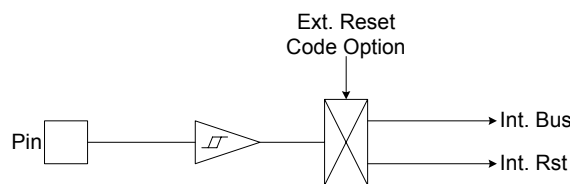

### Port 2, 5 structure:

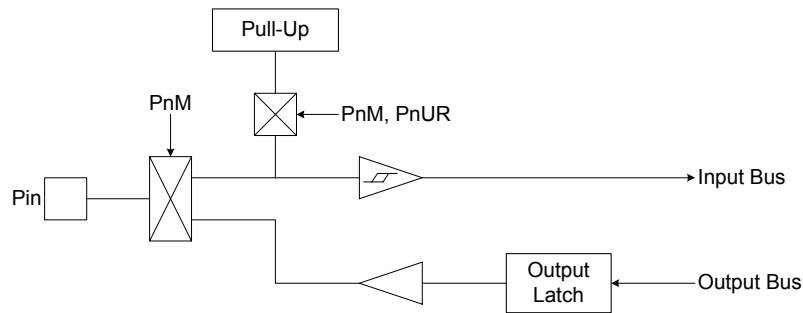

### Port 4 structure:

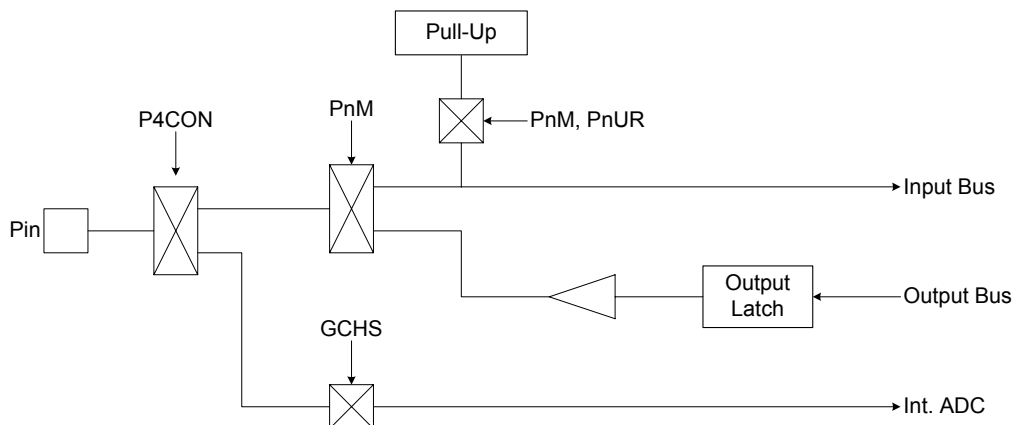

**Figure 10-1. The I/O pin circuit Diagram**

## 10.2 I/O PORT FUNCTION TABLE

Port/Pin	I/O	Function Description	Remark
P0.0~P0.1	I	General-purpose input function	P0.0: TC0 external clock input pin P0.1: TC1 external clock input pin
		External interrupt (INT0~INT1)	
		Wakeup for power down mode	
P0.2	I	General-purpose input function	
		Wakeup for power down mode	
P0.3	I	General-purpose input function	<b>No pull-up, No wakeup function</b>
		Share with Reset pin	
P2.0~P2.7	I/O	General-purpose input/output function	
P4.0~P4.7	I/O	General-purpose input/output function	
		ADC analog signal input	
P5.0~P5.6	I/O	General-purpose input/output function	

Table 10-1. I/O Function Table

## 10.3 PULL-UP RESISTERS

Pull-up register can set Pull-up register by Port. The typical pull-up register value is 200K@3V and 100K@5V.

### ➤ Port0

0E0H	Bit 7	Bit 6	Bit 5	Bit 4	Bit 3	Bit 2	Bit 1	Bit 0
<b>P0UR</b>	-	-	-	-	-	P02R	P01R	P00R
Read/Write	-	-	-	-	-	W	W	W
After reset	-	-	-	-	-	0	0	0

### ➤ Port2

0E2H	Bit 7	Bit 6	Bit 5	Bit 4	Bit 3	Bit 2	Bit 1	Bit 0
<b>P2UR</b>	P27r	P26R	P25R	P24R	P23R	P22R	P21R	P20R
Read/Write	W	W	W	W	W	W	W	W
After reset	0	0	0	0	0	0	0	0

### ➤ Port4

0E4H	Bit 7	Bit 6	Bit 5	Bit 4	Bit 3	Bit 2	Bit 1	Bit 0
<b>P4UR</b>	P47R	P46R	P45R	P44R	P43R	P42R	P41R	P40R
Read/Write	W	W	W	W	W	W	W	W
After reset	0	0	0	0	0	0	0	0

### ➤ Port5

0E5H	Bit 7	Bit 6	Bit 5	Bit 4	Bit 3	Bit 2	Bit 1	Bit 0
<b>P5UR</b>		P56R	P55R	P54R	P53R	P52R	P51R	P50R
Read/Write		W	W	W	W	W	W	W
After reset		0	0	0	0	0	0	0

### ➤ Example: I/O Pull up Register

```
CLR          P0UR          ; Disable Port0 Pull-up register.
```

```
MOV          A, #01H      ;  
B0MOV        P0UR, A      ; Enable Port0.0 Pull-up Register
```

## I/O PORT MODE

The port direction is programmed by PnM register. Port 0 is always input mode. Port 1,2,3,4 and 5 can select input or output direction.

### P2M initial value = 0000 0000

0C2H	Bit 7	Bit 6	Bit 5	Bit 4	Bit 3	Bit 2	Bit 1	Bit 0
<b>P2M</b>	P27M	P26M	P25M	P24M	P23M	P22M	P21M	P20M
	R/W	R/W	R/W	R/W	R/W	R/W	R/W	R/W

Bit [7:0] **P2 [7:0] M**: P2.0~P2.7 I/O direction control bit.  
 0 = Set P2 as input mode  
 1 = Set P2 as output mode

### P4M initial value = 0000 0000

0C4H	Bit 7	Bit 6	Bit 5	Bit 4	Bit 3	Bit 2	Bit 1	Bit 0
<b>P4M</b>	P47M	P46M	P45M	P44M	P43M	P42M	P41M	P40M
	R/W	R/W	R/W	R/W	R/W	R/W	R/W	R/W

Bit [7:0] **P4 [7:0] M**: P4.0~P4.7 I/O direction control bit.  
 0 = Set P4 as input mode  
 1 = Set P4 as output mode

### P5M initial value = x000 0000

0C5H	Bit 7	Bit 6	Bit 5	Bit 4	Bit 3	Bit 2	Bit 1	Bit 0
<b>P5M</b>		P56M	P55M	P54M	P53M	P52M	P51M	P50M
		R/W	R/W	R/W	R/W	R/W	R/W	R/W

Bit [6:0] **P5 [6:0] M**: P5.0~P5.6 I/O direction control bit.  
 0 = Set P5 as input mode  
 1 = Set P5 as output mode

➔ Example: I/O mode selecting.

```
CLR      P2M
CLR      P4M
CLR      P5M
```

```
MOV      A, #0FFH      ; Set all ports to be output mode.
B0MOV    P2M, A
B0MOV    P4M, A
B0MOV    P5M, A
```

```
B0BCLR   P2M.5      ; Set P2.5 to be input mode.
```

```
B0BSET   P2M.5      ; Set P2.5 to be output mode.
```

## 10.4 I/O PORT DATA REGISTER

### P0 initial value = xxxx xxxx

0D0H	Bit 7	Bit 6	Bit 5	Bit 4	Bit 3	Bit 2	Bit 1	Bit 0
<b>P0</b>	-	-	-	-	P03	P02	P01	P00
	-	-	-	-	R	R	R	R

### P2 initial value = xxxx xxxx

0D2H	Bit 7	Bit 6	Bit 5	Bit 4	Bit 3	Bit 2	Bit 1	Bit 0
<b>P2</b>	P27	P26	P25	P24	P23	P22	P21	P20
	R/W	R/W	R/W	R/W	R/W	R/W	R/W	R/W

### P4 initial value = xxxx xxxx

0D4H	Bit 7	Bit 6	Bit 5	Bit 4	Bit 3	Bit 2	Bit 1	Bit 0
<b>P4</b>	P47	P46	P45	P44	P43	P42	P41	P40
	R/W	R/W	R/W	R/W	R/W	R/W	R/W	R/W

### P5 initial value = xxxx xxxx

0D5H	Bit 7	Bit 6	Bit 5	Bit 4	Bit 3	Bit 2	Bit 1	Bit 0
<b>P5</b>		P56	P55	P54	P53	P52	P51	P50
		R/W	R/W	R/W	R/W	R/W	R/W	R/W

#### ⇒ Example: Read data from input port.

```

B0MOV      A, P0           ; Read data from Port 0
B0MOV      A, P2           ; Read data from Port 2
B0MOV      A, P4           ; Read data from Port 4
B0MOV      A, P5           ; Read data from Port 5

```

#### ⇒ Example: Write data to output port.

```

MOV        A, #55H        ; Write data 55H to Port 1, Port2, Port 4, Port 5
B0MOV      P2, A
B0MOV      P4, A
B0MOV      P5, A

```

➔ **Example: Write one bit data to output port.**

```
BOBSET      P2.3      ; Set P2.3 and P4.0 to be "1".  
BOBSET      P4.0  
  
BOBCLR      P2.3      ; Set P2.3 and P5.5 to be "0".  
BOBCLR      P5.5
```

➔ **Example: Port bit test.**

```
BOBTS1      P0.0      ; Bit test 1 for P0.0  
BOBTS0      P2.5      ; Bit test 0 for P2.5
```

# 11 8-CHANNEL ANALOG TO DIGITAL CONVERTER

## 11.1 OVERVIEW

This analog to digital converter of SN8P2710 has 8-input sources with up to 4096-step resolution to transfer analog signal into 12-bits digital data. The sequence of ADC operation is to select input source (AIN0 ~ AIN7) at first, then set GCHS and ADS bit to "1" to start conversion. When the conversion is complete, the ADC circuit will set EOC bit to "1" and final value output in ADB register.

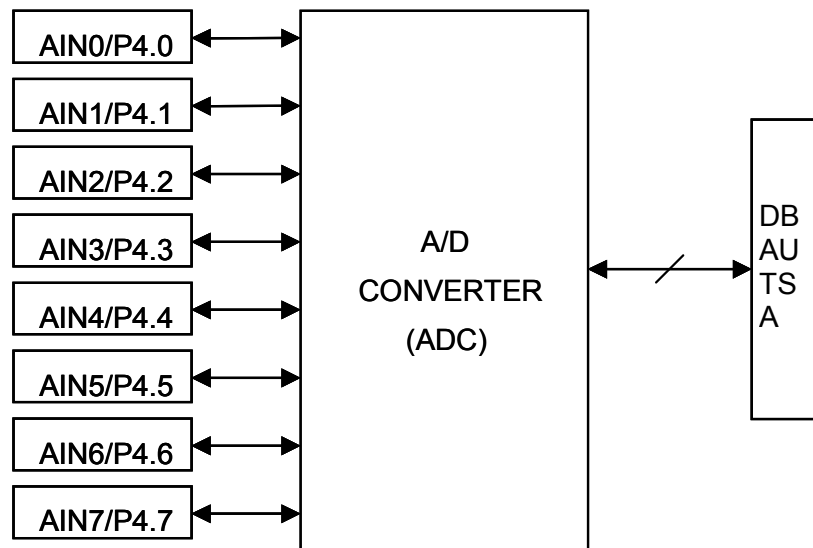

Figure 11-1. AD Converter Function Diagram

- **Note:** The analog input level must be between the AVREFH and AVREFL.
- **Note:** The AVREFH level must be between the AVDD and VSS + 2.0V.
- **Note:** ADC programming notice:
  - Set ADC input pin I/O direction as input mode
  - Disable pull-up resistor of ADC input pin
  - Disable ADC before enter power down (sleep) mode to save power consumption.
  - Set related bit of P4CON register to avoid extra power consumption in power down mode.
  - Delay 100uS after enable ADC (set ADENB = "1") to wait ADC circuit ready for conversion.
  - Disable ADC (set ADENB = "0") before enter sleep mode to save power consumption.



## 11.2 ADM REGISTER

**ADM initial value = 0000 x000**

0B1H	Bit 7	Bit 6	Bit 5	Bit 4	Bit 3	Bit 2	Bit 1	Bit 0
<b>ADM</b>	ADENB	ADS	EOC	GCHS	-	CHS2	CHS1	CHS0
	R/W	R/W	R/W	R/W	-	R/W	R/W	R/W

- Bit 7     **ADENB**: ADC control bit.  
0 = Disable ADC function  
1 = Enable ADC function
- Bit 6     **ADS**: ADC start bit.  
0 = ADC convert stop  
1 = ADC convert starting
- Bit 5     **EOC**: ADC status bit.  
0 = Progressing  
1 = End of converting and reset ADS bit
- Bit 4     **GCHS**: Global channel select bit.  
0 = Disable AIN channel  
1 = Enable AIN channel
- Bit [2:0]   **CHS [2:0]**: ADC input channels select bit.  
000 = AIN0, 001 = AIN1, 010 = AIN2, 011 = AIN3  
100 = AIN4, 101 = AIN5, 110 = AIN6, 111 = AIN7

## 11.3 ADR REGISTERS

**ADR initial value = x00x 0000**

0B3H	Bit 7	Bit 6	Bit 5	Bit 4	Bit 3	Bit 2	Bit 1	Bit 0
<b>ADR</b>		ADCKS1		ADCKS0	ADB3	ADB2	ADB1	ADB0
		R/W		R/W	R	R	R	R

- Bit 6,4    **ADCKS [1:0]**: ADC's clock source select bit.

ADCKS1	ADCKS0	ADC Clock Source
0	0	Fcpu/16
0	1	Fcpu/8
1	0	Fcpu
1	1	Fcpu/2

- Bit [3:0]   **ADB [3:0]**: ADC data buffer.  
ADB11~ADB0 bits for 12-bit ADC

## 11.4 ADB REGISTERS

**ADB initial value = xxxx xxxx**

0B2H	Bit 7	Bit 6	Bit 5	Bit 4	Bit 3	Bit 2	Bit 1	Bit 0
<b>ADB</b>	ADB11	ADB10	ADB9	ADB8	ADB7	ADB6	ADB5	ADB4
	R	R	R	R	R	R	R	R

ADB is ADC data buffer to store AD converter result. The ADB is only 8-bit register including bit 4~bit11 ADC data. To combine ADB register and the low-nibble of ADR will get full 12-bit ADC data buffer. The ADC buffer is a read-only register. the ADC data is stored in ADB and ADR registers.

- **Note: ADB [0:11] value is unknown when power on.**

**The AIN's input voltage v.s. ADB's output data**

AIN n	ADB1 1	ADB10	ADB9	ADB8	ADB7	ADB6	ADB5	ADB4	ADB3	ADB2	ADB1	ADB0
0/4095*AVREFH	0	0	0	0	0	0	0	0	0	0	0	0
1/4095*AVREFH	0	0	0	0	0	0	0	0	0	0	0	1
.	.	.	.	.	.	.	.	.	.	.	.	.
.	.	.	.	.	.	.	.	.	.	.	.	.
.	.	.	.	.	.	.	.	.	.	.	.	.
4094/4095*AVREFH	1	1	1	1	1	1	1	1	1	1	1	0
4095/4095*AVREFH	1	1	1	1	1	1	1	1	1	1	1	1

For different applications, users maybe need more than 8-bit resolution but less than 12-bit ADC converter. To process the ADB and ADR data can make the job well. First, the AD resolution must be set 12-bit mode and then to execute ADC converter routine. Then delete the LSB of ADC data and get the new resolution result. The table is as following.

ADC Resolution	ADB								ADR			
	ADB11	ADB10	ADB9	ADB8	ADB7	ADB6	ADB5	ADB4	ADB3	ADB2	ADB1	ADB0
8-bit	○	○	○	○	○	○	○	○	x	x	x	x
9-bit	○	○	○	○	○	○	○	○	○	x	x	x
10-bit	○	○	○	○	○	○	○	○	○	○	x	x
11-bit	○	○	○	○	○	○	○	○	○	○	○	x
12-bit	○	○	○	○	○	○	○	○	○	○	○	○

**○ = Selected, x = Delete**

## 11.5 P4CON REGISTERS

**ADB initial value = 0000 0000**

0AEH	Bit 7	Bit 6	Bit 5	Bit 4	Bit 3	Bit 2	Bit 1	Bit 0
<b>P4CON</b>	P4CON7	P4CON6	P4CON5	P4CON4	P4CON3	P4CON2	P4CON1	P4CON0
	W	W	W	W	W	W	W	W

The Port 4 is shared with ADC input function. Only one pin of port 4 can be configured as ADC input in the same time by ADM register. The other pins of port 4 are digital I/O pins. Connect an analog signal to COMS digital input pin, especially the analog signal level is about 1/2 VDD will cause extra current leakage. In the power down mode, the leakage current will be a big issue. Unfortunately, if users connect more than one analog input signal to port 4 will encounter above current leakage situation. P4CON is Port4 Configuration register. Write "1" into P4CON [7:0] will configure related port 4 pin as pure analog input pin to avoid current leakage.

Bit[7:0] **P4CON [7:0]** Port4 Configuration register.  
 0 = P4.X can be an analog input (ADC input) or digital I/O pins.  
 1 = P4.X is pure analog input, can't be a digital I/O pin.

**Note: When Port4 [7:0] is general I/O port not ADC channel, P4CON [7:0] must set to "0" or the Port4 input signal would be isolated**

## 11.6 ADC CONVERTING TIME

$$\text{12-bit ADC conversion time} = 1/(\text{ADC clock} / 4) * 16 \text{ sec}$$

High Clock (Fosc) = 4MHz

Fcpu	ADCKS1	ADCKS0	ADC Clock	ADC Converting Time	
Fosc/ 1	0	0	Fcpu/16	$1/((4\text{MHz} / 1) / 16 / 4) \times 16 =$	256 us
	0	1	Fcpu/8	$1/((4\text{MHz} / 1) / 8 / 4) \times 16 =$	128 us
	1	0	Fcpu	$1/((4\text{MHz} / 1) / 1 / 4) \times 16 =$	16 us
	1	1	Fcpu/2	$1/((4\text{MHz} / 1) / 2 / 4) \times 16 =$	32 us
Fosc/ 2	0	0	Fcpu/16	$1/((4\text{MHz} / 2) / 16 / 4) \times 16 =$	512 us
	0	1	Fcpu/8	$1/((4\text{MHz} / 2) / 8 / 4) \times 16 =$	256 us
	1	0	Fcpu	$1/((4\text{MHz} / 2) / 1 / 4) \times 16 =$	32 us
	1	1	Fcpu/2	$1/((4\text{MHz} / 2) / 2 / 4) \times 16 =$	64 us
Fosc/ 4	0	0	Fcpu/16	$1/((4\text{MHz} / 4) / 16 / 4) \times 16 =$	1024 us
	0	1	Fcpu/8	$1/((4\text{MHz} / 4) / 8 / 4) \times 16 =$	512 us
	1	0	Fcpu	$1/((4\text{MHz} / 4) / 1 / 4) \times 16 =$	64 us
	1	1	Fcpu/2	$1/((4\text{MHz} / 4) / 2 / 4) \times 16 =$	128 us
Fosc/ 8	0	0	Fcpu/16	$1/((4\text{MHz} / 8) / 16 / 4) \times 16 =$	2048 us
	0	1	Fcpu/8	$1/((4\text{MHz} / 8) / 8 / 4) \times 16 =$	1024 us
	1	0	Fcpu	$1/((4\text{MHz} / 8) / 1 / 4) \times 16 =$	128 us
	1	1	Fcpu/2	$1/((4\text{MHz} / 8) / 2 / 4) \times 16 =$	256 us

- **Note:** ADC function can work in slow mode also. In slow mode, the Fcpu = LXOSC / 4 (LXOSC is internal low RC oscillator).
- **Note:** Because the frequency of LXOSC (internal low RC oscillator) will vary with different temperature and VDD, so ADC converting time will be effected.

➤ **Example :** Configure AIN0 as 12-bit ADC input and start ADC conversion then enter power down mode.

ADC0:

```

BOBSET      FADENB      ; Enable ADC circuit
CALL        Delay100uS ; Delay 100uS to wait ADC circuit ready for conversion
MOV         A, #0FEh
BOBMV      P4UR, A      ; Disable P4.0 pull-up resistor
BOBCLR     FP40M        ; Set P4.0 as input pin
MOV         A, #01h
BOBMV      P4CON, A     ; Set P4.0 as pure analog input
MOV         A, #40H
BOBMV      ADR, A       ; To set 12-bit ADC and ADC clock = Fosc.
MOV         A, #90H
BOBMV      ADM, A       ; To enable ADC and set AIN0 input
BOBSET     FADS         ; To start conversion
    
```

WADC0:

```

BOBTS1     FEOC         ; To skip, if end of converting =1
JMP        WADC0       ; else, jump to WADC0
BOBMV      A, ADB       ; To get AIN0 input data bit11 ~ bit4
BOBMV      A, Adc_Buf_Hi, A
BOBMV      A, ADR       ; To get AIN0 input data bit3 ~ bit0
AND        A, 0Fh
BOBMV      A, Adc_Buf_Low, A
    
```

Power\_Down

```

BOBCLR     FADENB      ; Disable ADC circuit
BOBSET     FCPUM0      ; Enter sleep mode
    
```

## 11.7 ADC CIRCUIT

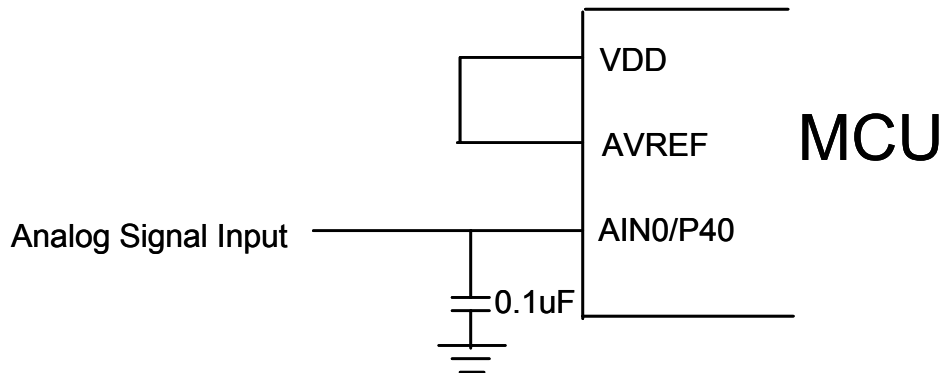

AVREFH is connected to VDD.

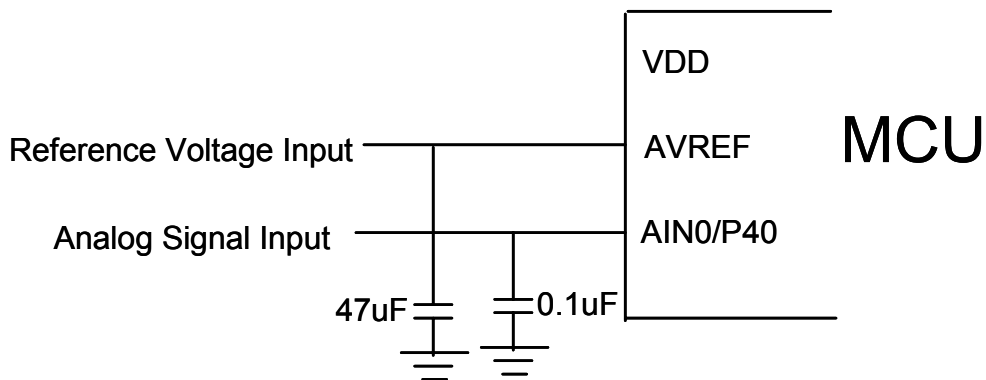

AVREFH is connected to external AD reference voltage.

Figure 11-2. The AINx and AVREFH Circuit of AD Converter

- **Note:** The capacitor between AIN and GND is a bypass capacitor. It is helpful to stable the analog signal. Users can omit it.

# 12 7-BIT DIGITAL TO ANALOG CONVERTER

## 12.1 OVERVIEW

The D/A converter uses 7-bit structure to synthesize 128 steps' analog signal with current source output. After DAENB bit is set to "1", DAC circuit will turn to be enabled and the DAM register, from bit0 to bit6, will send digital signal to ladder resistors in order to generate analog signal on DAO pin.



Figure 12-1. The DA converter Block Diagram

In order to get a proper linear output, a Loading Resistor  $R_L$  is usually added between DAO and Ground. The example shows the result of  $V_{dd} = 5V$ ,  $R_L = 150\text{ohm}$  and  $V_{dd} = 3V$ ,  $R_L = 150\text{ohm}$ .

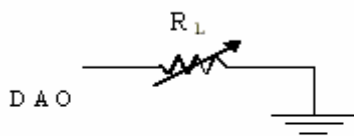

Figure 12-2 DAO Circuit with  $R_L$

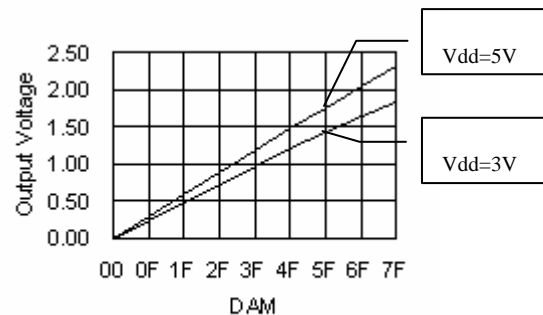

Figure 12-3. DAC Output Voltage in  $V_{dd}=5V$  and  $3V$

**Note:**

- \* 1: The D/A converter is not designed for a precise DC voltage output and is suitable for a simple audio application e.g. Tone or Melody generation.
- \* 2: For best linearity performance, the max. Loading Resistance  $R_L$  is 150 ohm @5V, 100 ohm @3V

## 12.2 DAM REGISTER

DAM initial value = 0000 0000

0B0H	Bit 7	Bit 6	Bit 5	Bit 4	Bit 3	Bit 2	Bit 1	Bit 0
<b>DAM</b>	DAENB	DAB6	DAB5	DAB4	DAB3	DAB2	DAB1	DAB0
	R/W	R/W	R/W	R/W	R/W	R/W	R/W	R/W

Bit 7 **DAENB**: Digital to Analog converter control bit.  
0 = Disable DAC function  
1 = Enable DAC function

Bit [6:0] **DAB [6:0]**: Digital input data.

## 12.3 D/A CONVERTER OPERATION

When the DAENB = 0, the DAO pin is output floating status. After setting DAENB to "1", the DAO output value is controlled by DAB bits.

➔ **Example: Output 1/2 VDD from DAO pin.**

```
MOV      A, #00111111B
BOMOV   DAM, A           ; Set DAB to a half of the full scale.

BOBSET  FDAENB          ; Enable D/A function.
```

The DAB's data v.s. DAO's output voltage as following:

DAB6	DAB5	DAB4	DAB3	DAB2	DAB1	DAB0	DAO
0	0	0	0	0	0	0	VSS
0	0	0	0	0	0	1	Idac
0	0	0	0	0	1	0	2 * Idac
0	0	0	0	0	1	1	3 * Idac
.	.	.	.	.	.	.	.
.	.	.	.	.	.	.	.
.	.	.	.	.	.	.	.
1	1	1	1	1	1	0	126 * Idac
1	1	1	1	1	1	1	127 * Idac

Table 12-1. DAB and DAO Relative Table

➤ **Note:**  $I_{dac} = I_{FSO} / (2^7 - 1)$  ( $I_{FSO}$ : Full-scale Output Current)

# 13 CODING ISSUE

## 13.1 TEMPLATE CODE

```

*****
;
; FILENAME   : TEMPLATE.ASM
; AUTHOR: SONiX
; PURPOSE    : Template Code for SN8P2710
; REVISION   : V1.0   First issue
;
*****
;* (c) Copyright 2004, SONiX TECHNOLOGY CO., LTD.
;
*****
CHIP      SN8P2715                ; Select the CHIP

;-----
;
;                               Include Files
;-----
.nolist                               ; do not list the macro file
    INCLUDESTD  MACRO1.H
    INCLUDESTD  MACRO2.H
    INCLUDESTD  MACRO3.H

.list                               ; Enable the listing function

;-----
;
;                               Constants Definition
;-----
;   ONE          EQU      1
;-----
;
;                               Variables Definition
;-----
.DATA
    org          0h                ;Bank 0 data section start from RAM address 0x000
    Wk00B0       DS          1      ;Temporary buffer for main loop
    lwk00B0      DS          1      ;Temporary buffer for ISR
    AccBuf       DS          1      ;Accumulater buffer
    PflagBuf    DS          1      ;PFLAG buffer

    org          100h              ;Bank 1 data section start from RAM address 0x100
    BufB1        DS          20     ;Temporary buffer in bank 1

;-----
;
;                               Bit Flag Definition
;-----
;   Wk00B0_0    EQU      Wk00B0.0 ;Bit 0 of Wk00B0
;   lwk00B0_1   EQU      lwk00B0.1 ;Bit 1 of lwk00

;-----
;
;                               Code section
;-----
.CODE

    ORG          0                ;Code section start
    jmp          Reset            ;Reset vector

```

```

;Address 4 to 7 are reserved
ORG      8
jmp      lsr          ;Interrupt vector

ORG      10h
;-----
; Program reset section
;-----
Reset:
mov      A,#07Fh     ;Initial stack pointer and
b0mov    STKP,A      ;disable global interrupt

clr      PFLAG       ;pflag = x,x,x,x,x,c,dc,z
mov      A,#00h      ;Initial system mode
b0mov    OSCM,A

mov      A, #0x5A
b0mov    WDTR, A     ;Clear watchdog timer

call     ClrRAM       ;Clear RAM
call     SysInit      ;System initial
b0bset   FGIE        ;Enable global interrupt

;-----
; Main routine
;-----
Main:
mov      A, #0x5A     ;Clear watchdog timer
b0mov    WDTR, A

call     MnApp

jmp      Main

;-----
; Main application
;-----
MnApp:
; Put your main program here
ret

;-----
; Jump table routine
;-----
ORG      0x0100      ;The jump table should start from the head
;of boundary.

b0mov    A,Wk00B0
and      A,#3
ADD      PCL,A
jmp      JmpSub0
jmp      JmpSub1
jmp      JmpSub2

;-----
JmpSub0:
; Subroutine 1
jmp      JmpExit
JmpSub1:

```



```

; Subroutine 2
jmp          JmpExit

JmpSub2:
; Subroutine 3
jmp          JmpExit

JmpExit:
ret          ;Return Main

;-----
; Isr (Interrupt Service Routine)
; Arguments   :
; Returns    :
; Reg Change:
;-----
Isr:
;-----
;   Save ACC and system registers
;-----
    b0xch      A,AccBuf          ;B0xch instruction do not change C,Z flag
    B0MOV     A, PFLAG
    B0MOV     PFLAGBUF, A

;-----
;   Check which interrupt happen
;-----

IntP00Chk:
    b0bts1    FP00IEN
    jmp       IntTc0Chk          ;Modify this line for another interrupt
    b0bts0    FP00IRQ
    jmp       P00isr

;If necessary, insert another interrupt checking here

IntTc0Chk:
    b0bts1    FTC0IEN
    jmp       IsrExit            ;Suppose TC0 is the last interrupt which you
    b0bts0    FTC0IRQ          ;want to check
    jmp       TC0isr

;-----
; Exit interrupt service routine
;-----
IsrExit:
    B0MOV     A, PFLAGBUF
    B0MOV     PFLAG, A
    b0xch     A,AccBuf          ;B0xch instruction do not change C,Z flag

    reti          ;Exit the interrupt routine

;-----
;   INT0 interrupt service routine
;-----
P00isr:
    b0bclr    FP00IRQ

```

```

;Process P0.0 external interrupt here

jmp          IsrExit

;-----
; TC0 interrupt service routine
;-----
TC0ISR:
    b0bclr          FTC0IRQ

;Process TC0 timer interrupt here

jmp          IsrExit

;-----
; SysInit
; Initialize I/O, Timer, Interrupt, etc.
;-----
SysInit:
    ret

;-----
; ClrRAM
; Use index @YZ to clear RAM (00h~7Fh)
;-----

ClrRAM:

; RAM Bank 0
    clr          Y                ;Select bank 0
    b0mov        Z,#0x7f         ;Set @YZ address from 7fh

ClrRAM10:
    clr          @YZ              ;Clear @YZ content
    decms        Z                ;z = z - 1 , skip next if z=0
    jmp          ClrRAM10
    clr          @YZ              ;Clear address 0x00
    ret

;-----
ENDP

```

## 13.2 PROGRAM CHECK LIST

Item	Description
<b>Undefined Bits</b>	All bits those are marked as "0" (undefined bits) in system registers should be set "0" to avoid unpredicted system errors.
<b>ADC</b>	<ol style="list-style-type: none"> <li>1. Set ADC input pin I/O direction as input mode</li> <li>2. Disable pull-up resistor of ADC input pin</li> <li>3. Disable ADC before enter power down (sleep) mode to save power consumption.</li> <li>4. Set related bit of P4CON to avoid extra power consumption in power down mode</li> <li>5. Delay 100uS after enable ADC (set ADENB = "1") to wait ADC circuit ready for conversion</li> </ol>
<b>Interrupt</b>	Do not enable interrupt before initializing RAM.
<b>Non-Used I/O</b>	Non-used I/O ports should be pull-up or pull-down in input mode, or be set as low in output mode to save current consumption.
<b>Sleep Mode</b>	Enable on-chip pull-up resistors of port 0 to avoid unpredicted wakeup.
<b>Stack Buffer</b>	Be careful of function call and interrupt service routine operation. Don't let stack buffer overflow or underflow.
<b>System Initial</b>	<ol style="list-style-type: none"> <li>1. Write 0x7F into STKP register to initial stack pointer and disable global interrupt</li> <li>2. Clear all RAM.</li> <li>3. Initialize all system register even unused registers.</li> <li>4. Initialize all I/O pin direction.</li> </ol>
<b>Noisy Immunity</b>	<ol style="list-style-type: none"> <li>1. Set the watchdog option as "Always On" to protect system crash.</li> <li>2. Enable "Noise Filter" code option</li> <li>3. Non-used I/O ports should be set as output low mode</li> <li>4. Constantly refresh important system registers and variables in RAM to avoid system crash by a high electrical fast transient noise.</li> </ol>

# 14 INSTRUCTION SET TABLE

Field	Mnemonic	Description	C	DC	Z	Cycle
MOV	MOV A,M	$A \leftarrow M$	-	-	√	1
	MOV M,A	$M \leftarrow A$	-	-	-	1
	BOMOV A,M	$A \leftarrow M$ (bank 0)	-	-	√	1
	BOMOV M,A	$M$ (bank 0) $\leftarrow A$	-	-	-	1
	MOV A,I	$A \leftarrow I$	-	-	-	1
	BOMOV M,I	$M \leftarrow I$ , "M" only supports 0x80~0x87 registers (e.g. PFLAG,R,Y,Z...),	-	-	-	1
	XCH A,M	$A \leftrightarrow M$	-	-	-	1+N
	BOXCH A,M	$A \leftrightarrow M$ (bank 0),	-	-	-	1+N
MOVC	R, $A \leftarrow ROM$ [Y,Z]	-	-	-	2	
ARITH	ADC A,M	$A \leftarrow A + M + C$ , if occur carry, then C=1, else C=0	√	√	√	1
	ADC M,A	$M \leftarrow A + M + C$ , if occur carry, then C=1, else C=0	√	√	√	1+N
	ADD A,M	$A \leftarrow A + M$ , if occur carry, then C=1, else C=0	√	√	√	1
	ADD M,A	$M \leftarrow M + A$ , if occur carry, then C=1, else C=0	√	√	√	1+N
	BOADD M,A	$M$ (bank 0) $\leftarrow M$ (bank 0) + A, if occur carry, then C=1, else C=0	√	√	√	1+N
	ADD A,I	$A \leftarrow A + I$ , if occur carry, then C=1, else C=0	√	√	√	1
	SBC A,M	$A \leftarrow A - M - /C$ , if occur borrow, then C=0, else C=1	√	√	√	1
	SBC M,A	$M \leftarrow A - M - /C$ , if occur borrow, then C=0, else C=1	√	√	√	1+N
	SUB A,M	$A \leftarrow A - M$ , if occur borrow, then C=0, else C=1	√	√	√	1
	SUB M,A	$M \leftarrow A - M$ , if occur borrow, then C=0, else C=1	√	√	√	1+N
SUB A,I	$A \leftarrow A - I$ , if occur borrow, then C=0, else C=1	√	√	√	1	
LOGIC	AND A,M	$A \leftarrow A$ and M	-	-	√	1
	AND M,A	$M \leftarrow A$ and M	-	-	√	1+N
	AND A,I	$A \leftarrow A$ and I	-	-	√	1
	OR A,M	$A \leftarrow A$ or M	-	-	√	1
	OR M,A	$M \leftarrow A$ or M	-	-	√	1+N
	OR A,I	$A \leftarrow A$ or I	-	-	√	1
	XOR A,M	$A \leftarrow A$ xor M	-	-	√	1
	XOR M,A	$M \leftarrow A$ xor M	-	-	√	1+N
XOR A,I	$A \leftarrow A$ xor I	-	-	√	1	
PUSH	SWAP M	$A$ (b3~b0, b7~b4) $\leftarrow M$ (b7~b4, b3~b0)	-	-	-	1
	SWAPM M	$M$ (b3~b0, b7~b4) $\leftarrow M$ (b7~b4, b3~b0)	-	-	-	1+N
	RRC M	$A \leftarrow RRC$ M	√	-	-	1
	RRCM M	$M \leftarrow RRC$ M	√	-	-	1+N
	RLC M	$A \leftarrow RLC$ M	√	-	-	1
	RLCM M	$M \leftarrow RLC$ M	√	-	-	1+N
	CLR M	$M \leftarrow 0$	-	-	-	1
	BCLR M.b	$M.b \leftarrow 0$	-	-	-	1+N
	BSET M.b	$M.b \leftarrow 1$	-	-	-	1+N
	BOBCLR M.b	$M$ (bank 0).b $\leftarrow 0$	-	-	-	1+N
BOBSET M.b	$M$ (bank 0).b $\leftarrow 1$	-	-	-	1+N	
BRANCH	CMPRS A,I	ZF,C $\leftarrow A - I$ , If A = I, then skip next instruction	√	-	√	1 + S
	CMPRS A,M	ZF,C $\leftarrow A - M$ , If A = M, then skip next instruction	√	-	√	1 + S
	INCS M	$A \leftarrow M + 1$ , If A = 0, then skip next instruction	-	-	-	1 + S
	INCMS M	$M \leftarrow M + 1$ , If M = 0, then skip next instruction	-	-	-	1+N+S
	DECS M	$A \leftarrow M - 1$ , If A = 0, then skip next instruction	-	-	-	1 + S
	DECMS M	$M \leftarrow M - 1$ , If M = 0, then skip next instruction	-	-	-	1+N+S
	BOBTS0 M.b	If M(bank 0).b = 0, then skip next instruction	-	-	-	1 + S
	BOBTS1 M.b	If M(bank 0).b = 1, then skip next instruction	-	-	-	1 + S
	JMP D	PC15/14 $\leftarrow$ RomPages1/0, PC13~PC0 $\leftarrow$ d	-	-	-	2
	CALL D	Stack $\leftarrow$ PC15~PC0, PC15/14 $\leftarrow$ RomPages1/0, PC13~PC0 $\leftarrow$ d	-	-	-	2
MISC	RET	PC $\leftarrow$ Stack	-	-	-	2
	RETI	PC $\leftarrow$ Stack, and to enable global interrupt	-	-	-	2
	NOP	No operation	-	-	-	1
RETLW I	PC $\leftarrow$ Stack, A $\leftarrow$ I	-	-	-	2	

➤ **Note:**

1. The "M" is memory including system registers and user defined memory.
2. If branch condition is true then "S = 1", otherwise "S = 0".
3. If "M" is system registers (80h ~ FFh of bank 0) then "N" = 0, otherwise "N" = 1

# 15 ELECTRICAL CHARACTERISTIC

## 15.1 ABSOLUTE MAXIMUM RATING

(All of the voltages referenced to Vss)

Supply voltage (Vdd).....	- 0.3V ~ 6.0V
Input in voltage (Vin).....	Vss - 0.2V ~ Vdd + 0.2V
Operating ambient temperature (Topr)	
SN8P27142P, SN8P27142S, SN8P27143P, SN8P27143S, SN8P27143X, SN8P2714K, SN8P2714S, SN8P2715P, SN8P2715S.....	0°C ~ + 70°C
SN8P27142PD, SN8P27142SD, SN8P27143PD, SN8P27143SD, SN8P27143XD, SN8P2714KD, SN8P2714SD, SN8P2715PD, SN8P2715SD.....	-40°C ~ + 85°C
Storage ambient temperature (Tstor) .....	-40°C ~ + 125°C

## 15.2 STANDARD ELECTRICAL CHARACTERISTIC

(All of voltages referenced to Vss, Vdd = 5.0V, fosc = 4 MHz, Fcpu=1MHZ, ambient temperature is 25°C unless otherwise note.)

PARAMETER	SYM.	DESCRIPTION	MIN.	TYP.	MAX.	UNIT
Operating voltage	Vdd	Normal mode, Vpp = Vdd, 25°C	2.4	5.0	5.5	V
		Normal mode, Vpp = Vdd, -40°C~85°C	2.5	5.0	5.5	
		Programming mode, Vpp = 12.5V		5.0		
RAM Data Retention voltage	Vdr		1.5	-	-	V
Internal POR	Vpor	Vdd rise rate to ensure internal power-on reset	0.05	-	-	V/ms
Input Low Voltage	ViL1	All input ports	Vss	-	0.3Vdd	V
	ViL2	Reset pin	Vss	-	0.2Vdd	V
Input High Voltage	ViH1	All input ports	0.7Vdd	-	Vdd	V
	ViH2	Reset pin	0.9Vdd	-	Vdd	V
Reset pin leakage current	Ilekg	Vin = Vdd, 25°C	-	-	2	uA
		Vin = Vdd, -40°C~85°C	-	-	5	uA
I/O port pull-up resistor	Rup	Vin = Vss, Vdd = 3V	100	200	300	KΩ
		Vin = Vss, Vdd = 5V	50	100	180	KΩ
I/O port input leakage current	Ilekg	Pull-up resistor disable, Vin = Vdd	-	-	2	uA
Port2, Port4, Port 5 output current	IoH	Vop = Vdd - 0.5V(source)	8	12	-	mA
	IoL	Vop = Vss + 0.5V(sink)	8	15	-	mA
INTn trigger pulse width	Tint0	INT0 ~ INT1 interrupt request pulse width	2/fcpu	-	-	Cycle
AVREFH input voltage	Varfh	Vdd = 5.0V	2V	-	Vdd	V
AIN0 ~ AIN7 input voltage	Vani	Vdd = 5.0V	0	-	Varfh	V
ADC Clock Frequency	F <sub>ADCLK</sub>	VDD=5.0V	-	-	8M	Hz
		VDD=3.0V	-	-	5M	Hz
ADC Conversion Cycle Time	F <sub>ADCYL</sub>	VDD=2.4V~5.5V	64			1/F <sub>ADCLK</sub>
ADC Sampling Rate (Set FADS=1 Frequency)	F <sub>ADSMP</sub>	VDD=5.0V			125	K/sec
		VDD=3.0V			80	K/sec
Differential Nonlinearity	DNL	VDD=5.0V, AVREFH=3.2V, F <sub>ADSMP</sub> =7.8K	±1	±2	±16	LSB
Integral Nonlinearity	INL	VDD=5.0V, AVREFH=3.2V, F <sub>ADSMP</sub> =7.8K	±2	±4	±16	LSB
No Missing Code	NMC	VDD=5.0V, AVREFH=3.2V, F <sub>ADSMP</sub> =7.8K	8	10	12	Bits
ADC enable time	Tast	Ready to start convert after set ADENB = "1"	100	-	-	uS
ADC current consumption	I <sub>ADC</sub>	Vdd=5.0V	-	0.6*	-	mA
		Vdd=3.0V	-	0.4*	-	mA
DAC Full-scale Output Current	I <sub>FSD</sub>	Vdd=5V, 25°C	8	14	21	mA
		Vdd=3V, 25°C	5	11	18	mA
		Vdd=5V, -40°C~85°C	8	18	27	mA
		Vdd=3V, -40°C~85°C	5	15	24	mA
DAC Loading Resistance	R <sub>L</sub>	Vdd=5V	-	-	150	Ω
		Vdd=3V	-	-	100	Ω
DAC DNL	DAC <sub>DNL</sub>	DAC Differential NonLinearity	-	±1*	-	LSB
DAC INL	DAC <sub>INL</sub>	DAC Integral NonLinearity	-	±3*	-	LSB
Supply Current (Disable ADC)	I <sub>dd1</sub>	normal Mode	-	2.5	5	mA
		Fcpu = Fosc/4	Vdd= 5V 4MHz	-	1.5	3
			Vdd= 3V 4MHz	-		

	Idd2	Slow Mode (Internal RC mode, Stop high clock)	Vdd= 5V ~ ILRC 32Khz	-	25	50	uA
			Vdd= 3V ~ ILRC 16Khz	-	5	10	uA
	Idd3	Sleep mode (LVD = LVD_L)	Vdd= 5V, 25°C	-	1	2	uA
			Vdd= 3V, 25°C	-	0.6	1	uA
Vdd= 5V, -40°C~85°C			-	10	21	uA	
			Vdd= 3V, -40°C~85°C	-	10	21	uA
LVD Voltage	Vdet0	Low voltage reset level		1.7	2.0	2.3	V
	Vdet1	Low voltage reset/indicator level Fcpu=1MHz		2.0	2.4	3	V
	Vdet2	Low voltage indicator level Fcpu=1MHz		2.7	3.6	4.5	V

\*These parameters are for design reference, not tested.

## 15.3 CHARACTERISTIC GRAPHS

The Graphs in this section are for design guidance, not tested or guaranteed. In some graphs, the data presented are outside specified operating range. This is for information only and devices are guaranteed to operate properly only within the specified range.

**Standby current**

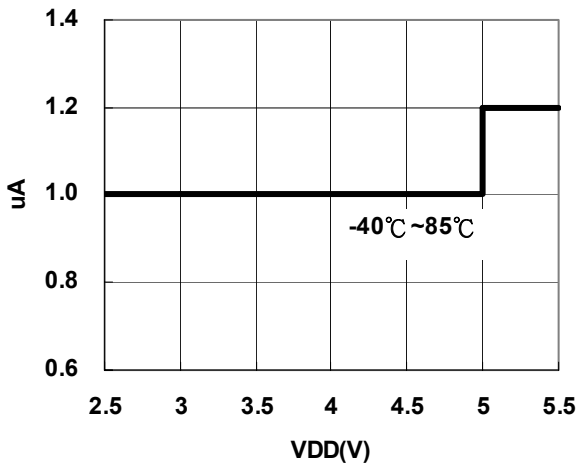

**Slow mode current**

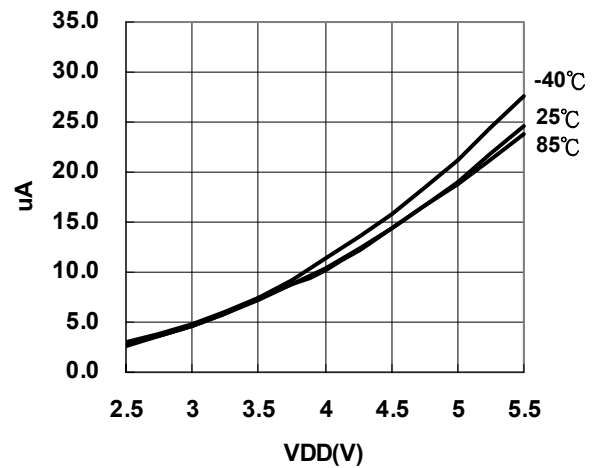

**Operating current (Fosc=4MHZ、  
Fcpu=Fosc/4)**

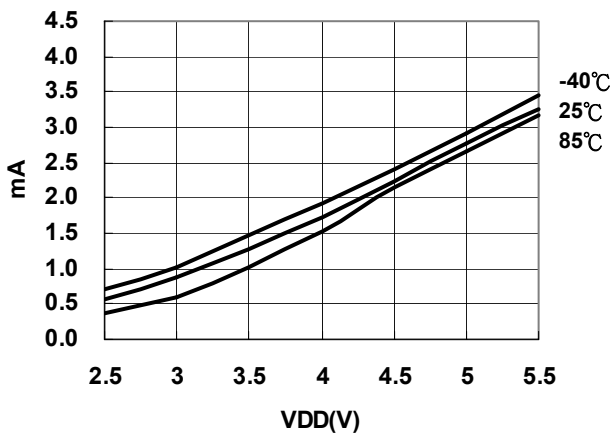

**Pull up resistor (ALL PORT)**

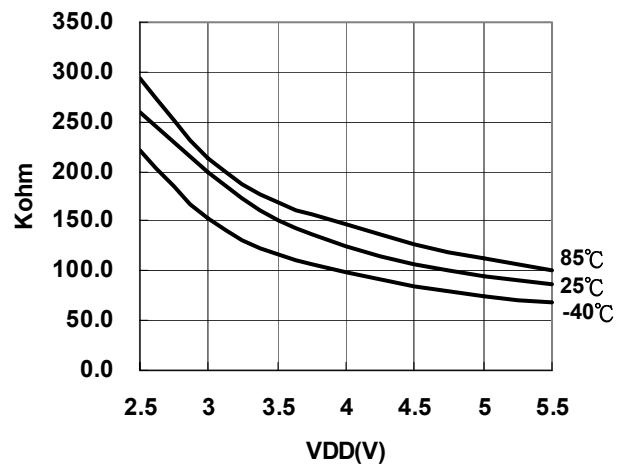

VIH(PORT2、PORT5)

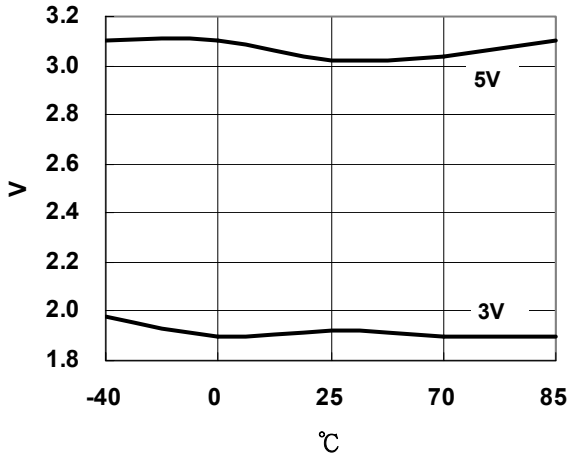

VIL(PORT2、PORT5)

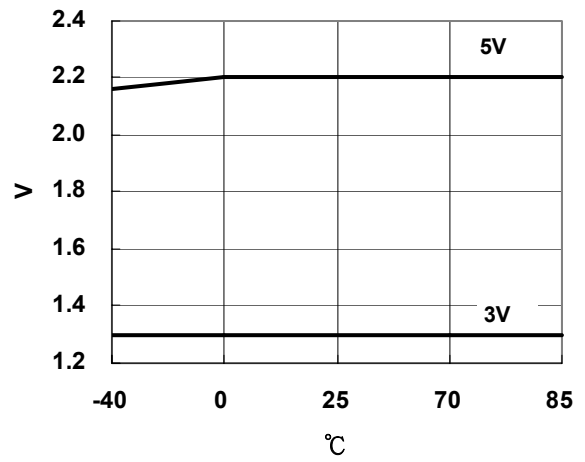

VIH(PORT4)

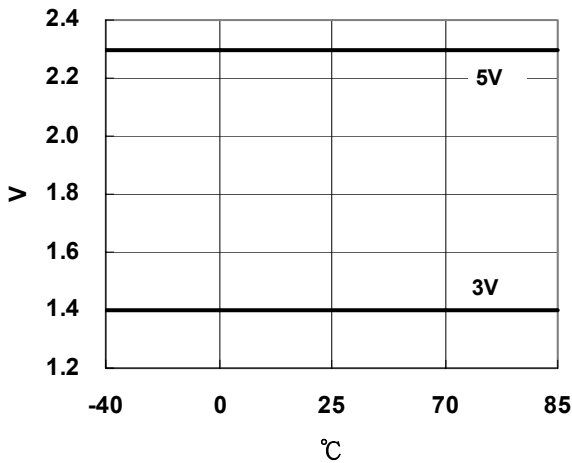

VIL(PORT4)

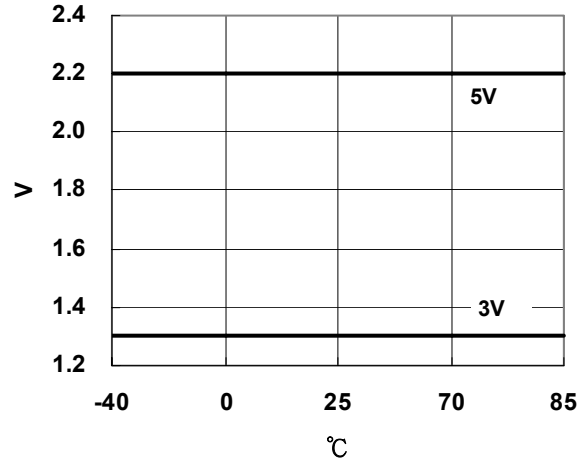

Driving current (ALL PORT)

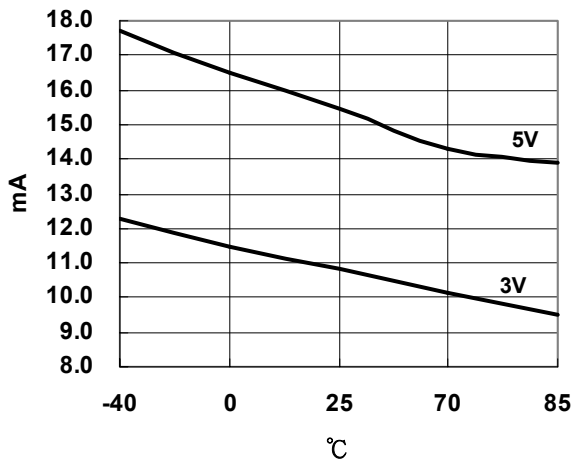

Sinking current (ALL PORT)

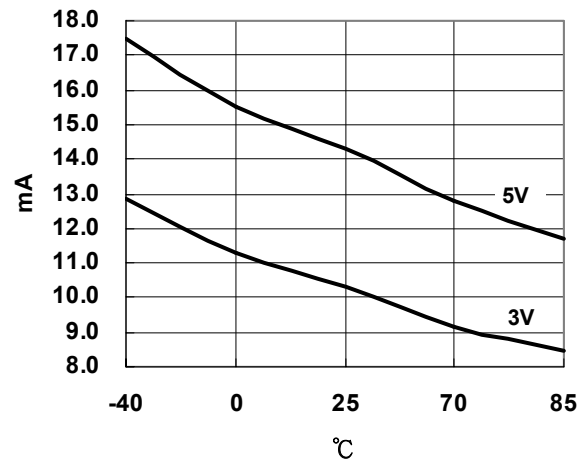

Internal low RC Oscillator

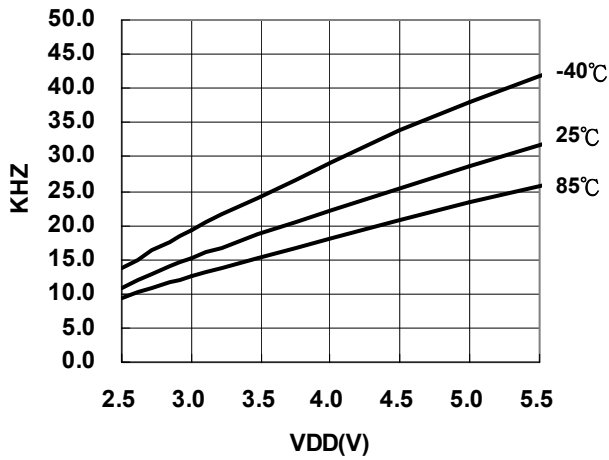

External RC Oscillator (25°C)

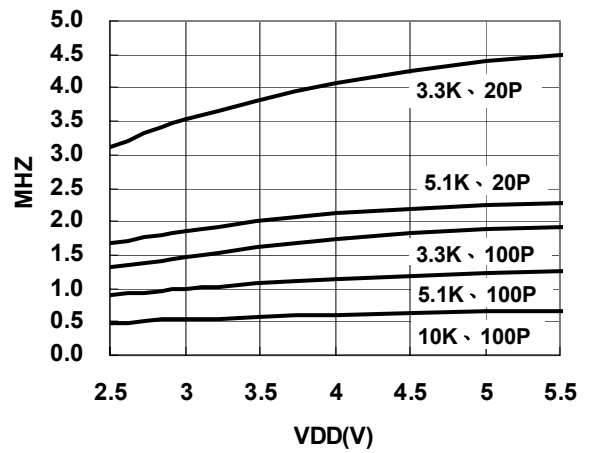

Fcpu=Fosc/1, Noise Filter Disable, -40~85°C

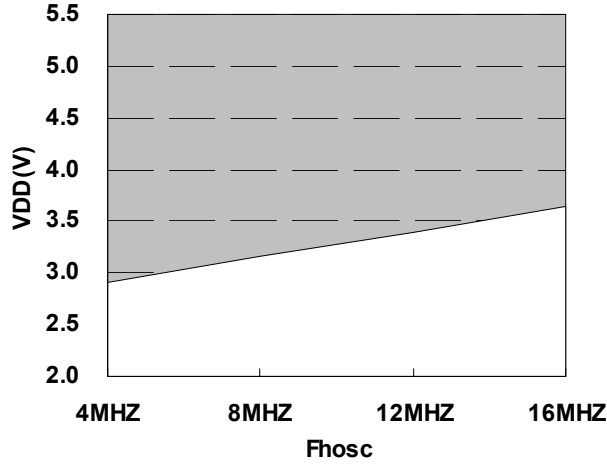

Fcpu=Fosc/4, Noise Filter Disable, -40~85°C

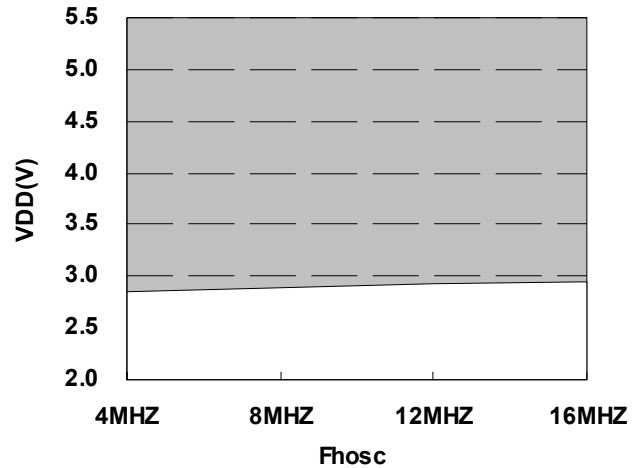

Fcpu=Fosc/4, Noise Filter Enable, -40~85°C

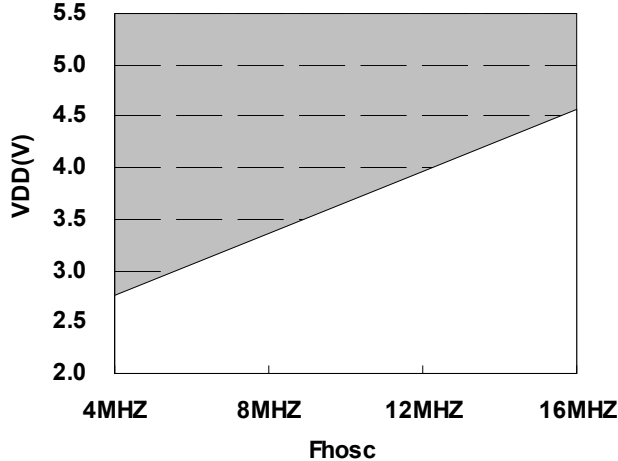

Fcpu=Fosc/1, Noise Filter Disable, 0~70°C

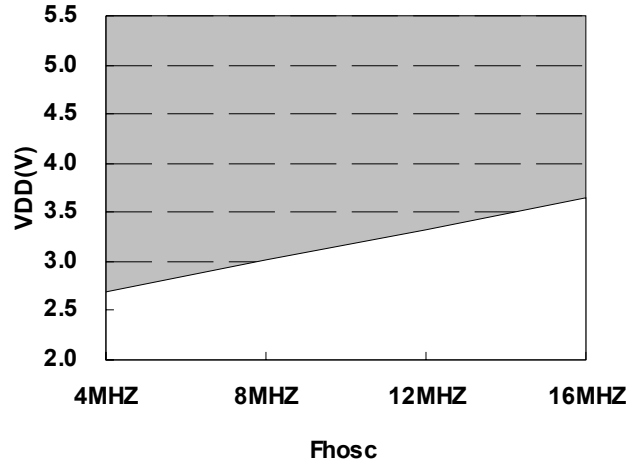



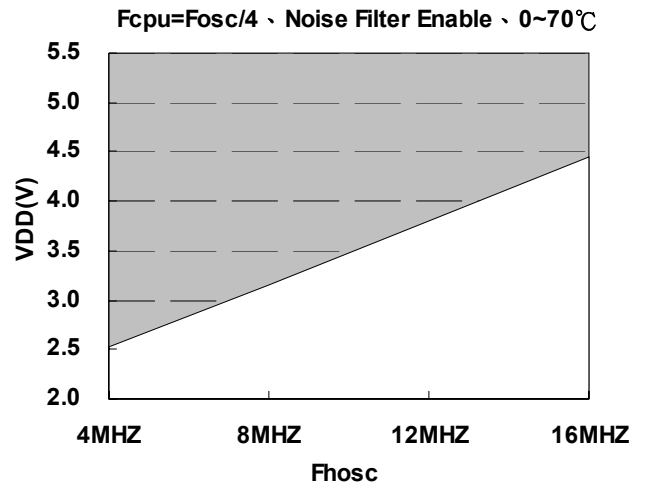
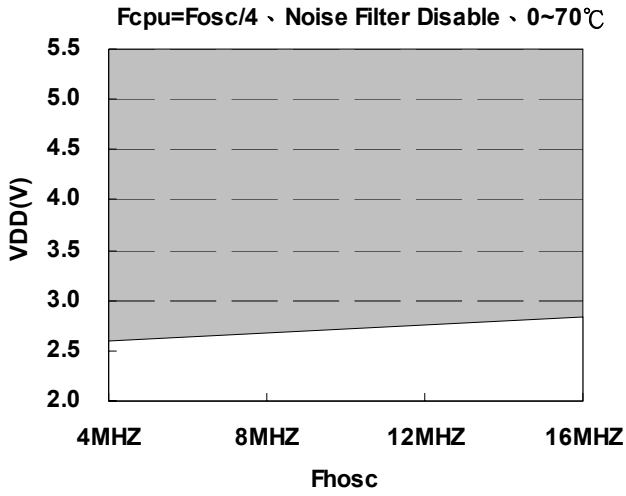

# 16 Development Tools

## 16.1 Development Tool Version

### 16.1.1 ICE (In circuit emulation)

- **SN8ICE 2K:** Full function emulates SN8P2714/SN8P2715 series

- \* **SN8ICE2K ICE emulation notice**

- a. Operation voltage of ICE: 3.0V~5.0V.
- b. Recommend maximum emulation speed at 5V: 8 MIPS (e.g. 16MHZ crystal and  $F_{cpu} = F_{hosc}/2$ ).
- c. Use SN8P2714 / 2715 EV-KIT to emulation LVD.

- \* **Note:** S8KD-2 ICE doesn't support SN8P2714X and SN8P2715 serial emulation.

### 16.1.2 OTP Writer

- **Writer 3.0:** Support SN8P2715/SN8P2714 but no Stand-alone mode.
- **Easy Writer V1.0:** OTP programming is controlled by ICE without firmware upgrade suffers. Please refer easy writer user manual for detailed information.
- **MP-EZ Writer V1.0:** Stand-alone operation to support SN8P2715/SN8P2714 mass production

### 16.1.3 IDE (Integrated Development Environment)

SONiX 8-bit MCU integrated development environment include Assembler, ICE debugger and OTP writer software.

- **For SN8ICE 2K:** M2IDE V1.07 or later
- **For Writer 3.0, Easy Writer and MP-Easy Writer:** M2IDE V1.07 or later
- **SN8IDE V1.99X** doesn't support SN8P2714X and SN8P2715.

## 16.2 SN8P2715/SN8P2714 EV-KIT

### 16.2.1 PCB DESCRIPTION

SONiX provides SN8P2715 EV-Kit board for ICE emulation. The EV-Kit provide LVD2.4V/3.6V selection circuit emulation.

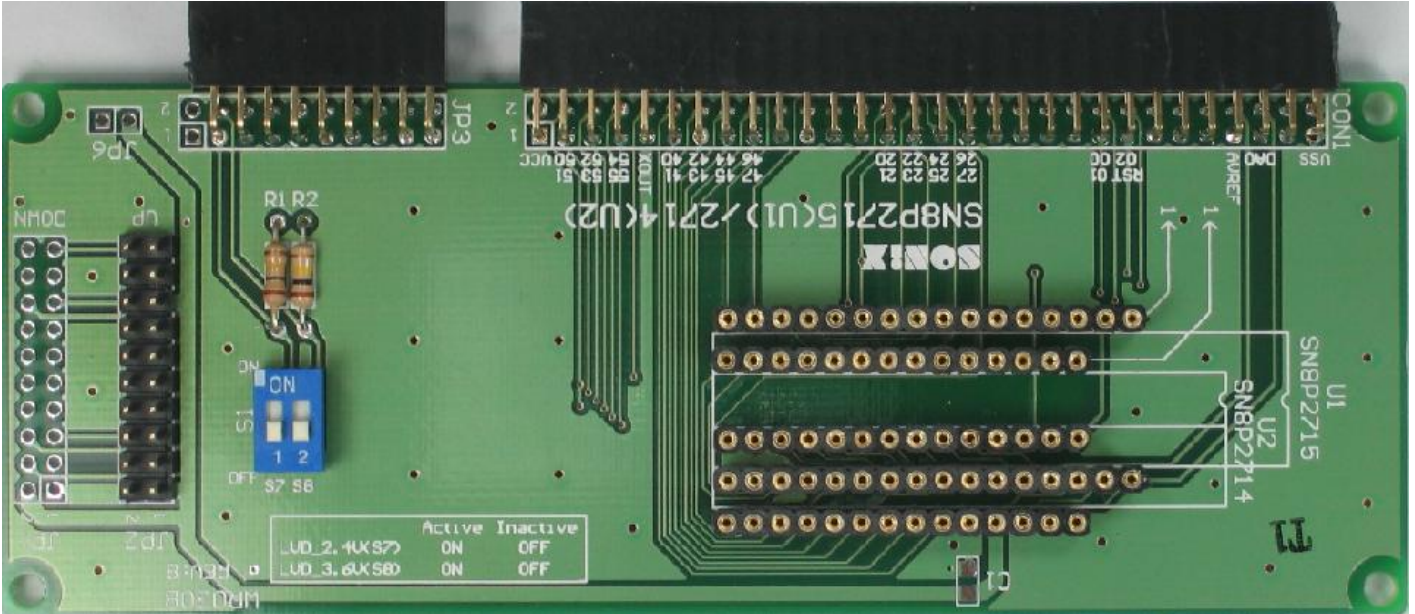

**CON1 and JP3** :ICE I/O interface.

**S1**: VD 2.4V and LVD 3.6V trigger control. To emulate LVD 2.4V flag/reset function and LVD 3.6V flag function.

Switch No.	On	Off	Note
S7	LVD 2.4V Active	LVD 2.4V Inactive	Emulate VDD is lower than 2.4V
S8	LVD 3.6V Active	LVD 3.6V Inactive	Emulate VDD is lower than 3.6V

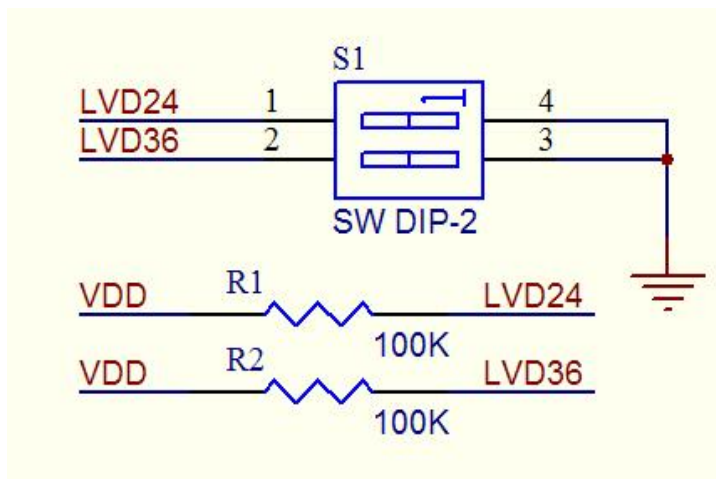

## 16.3 SN8P2715/14 EV-KIT CONNECT TO SN8ICE 2K

The connection from SN8P2715/14 EV-KIT to SN8ICE 2K is as following.

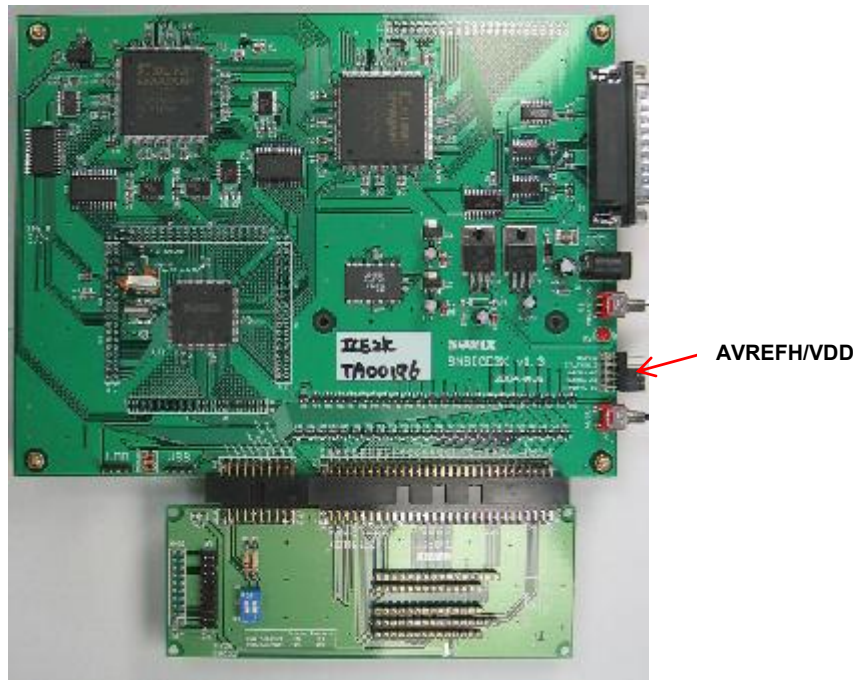

- \* SN8ICE2K ICE emulation notice
  - a: Operation voltage of ICE: 3.0V~5.0V.
  - b: Recommend maximum emulation speed at 5V: 8 MIPS(e.g. 16MHZ crystal and  $F_{cpu} = F_{osc}/2$ ).
  - c: Use SN8P2715 EV-KIT to emulation LVD.
  - d: Remove AVREFH/VDD jumper of SN8ICE 2K when Chip declare as SN8P2715/SN8P2714/SN8P27143 .

## 16.4 TRANSITION BOARD FOR OTP PROGRAMMING

### 16.4.1 SN8P2715/2715 Rev. B TRANSITION BOARD

SN8P2715/2714 Rev. B transition board is for SN8P2715/2714 OTP programming including P-DIP 20 pins and P-DIP 18 pins. Rev. B transition board and EV-Kit is the same board.

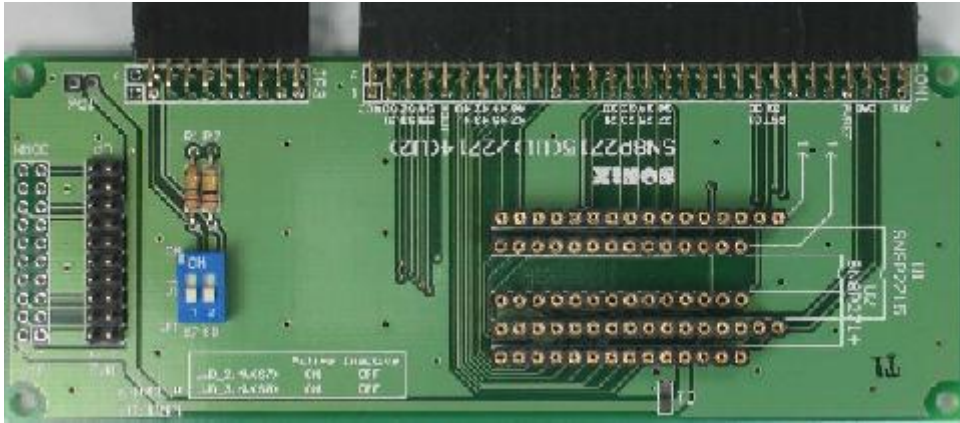

**JP2:** Connect to Easy writer or MP-EZ writer through 20 pins cable.

**U1:** SN8P2715 P-DIP 32 pins socket

**U2:** SN8P2714 P-DIP 28 pins socket

### 16.4.2 CONNECT Rev. B TRANSITION BOARD TO EASY WRITER



**MP-EZ Writer**

**Rev. B Transition Board**

## 16.5 OTP Programming Pin to Transition Board Mapping

### 16.5.1 The pin assignment of Easy and MP EZ Writer transition board socket:

Easy Writer JP1/JP2			Easy Writer JP3 (Mapping to 48-pin text tool)			
VSS	2	1	VDD	DIP1	1 48	DIP48
CE	4	3	CLK/PGCLK	DIP2	2 47	DIP47
OE/ShiftDat	6	5	PGM/OTPCLK	DIP3	3 46	DIP46
D0	8	7	D1	DIP4	4 45	DIP45
D2	10	9	D3	DIP5	5 44	DIP44
D4	12	11	D5	DIP6	6 43	DIP43
D6	14	13	D7	DIP7	7 42	DIP42
VPP	16	15	VDD	DIP8	8 41	DIP41
RST	18	17	HLS	DIP9	9 40	DIP40
ALSB/PDB	20	19	-	DIP10	10 39	DIP39
				DIP11	11 38	DIP38
				DIP12	12 37	DIP38
				DIP13	13 36	DIP36
				DIP14	14 35	DIP35
				DIP15	15 34	DIP34
				DIP16	16 33	DIP33
				DIP17	17 32	DIP32
				DIP18	18 31	DIP31
				DIP19	19 30	DIP30
				DIP20	20 29	DIP29
				DIP21	21 28	DIP28
				DIP22	22 27	DIP27
				DIP23	23 26	DIP26
				DIP24	24 25	DIP25

**JP1 for MP transition board**  
**JP2 for Writer V3.0 transition board**

**JP3 for MP transition board**

### 16.5.2 The pin assignment of Writer V3.0 transition board socket:

GND	2	1	VDD
CE	4	3	CLK
OE	6	5	PGM
D0	8	7	D1
D2	10	9	D3
D4	12	11	D5
D6	14	13	D7
VPP	16	15	VDD
RST	18	17	HLS
	20	19	

Writer V3.0 JP1 Pin Assignment

### 16.5.3 SN8P2710 Series Programming Pin Mapping:

OTP Programming Pin of SN8P2710 Series											
Chip Name		SN8P2714		SN8P2715		SN8P27142		SN8P27143			
Easy, MP-EZ Writer And Writer V3.0		OTP IC / JP3 Pin Assignment									
Number	Pin	Number	Pin	Number	Pin	Number	Pin	Number	Pin		
1	VDD	25	VDD	30	VDD	12	VDD	13	VDD		
2	GND	15	VSS	20	VSS	6	VSS	5	VSS		
3	CLK	4	P5.0	6	P5.0	17	P5.0	18	P5.0		
4	CE	-	-	-	-	-	-	-	-		
5	PGM	8	P2.0	10	P2.0	2	P2.0	1	P2.0		
6	OE	3	P5.1	5	P5.1	16	P5.1	17	P5.1		
7	D1	-	-	-	-	-	-	-	-		
8	D0	-	-	-	-	-	-	-	-		
9	D3	-	-	-	-	-	-	-	-		
10	D2	-	-	-	-	-	-	-	-		
11	D5	-	-	-	-	-	-	-	-		
12	D4	-	-	-	-	-	-	-	-		
13	D7	-	-	-	-	-	-	-	-		
14	D6	-	-	-	-	-	-	-	-		
15	VDD	25	VDD	30	VDD	12	VDD	13	VDD		
16	VPP	26	RST	31	RST	13	RST	14	RST		
17	HLS	-	-	-	-	-	-	-	-		
18	RST	-	-	-	-	-	-	-	-		
19	-	-	-	-	-	-	-	-	-		
20	ALSB/PDB	9	P2.1	11	P2.1	3	P2.1	2	P2.1		

# 17 Marking Definition

## 17.1 INTRODUCTION

There are many different types in Sonix 8-bit MCU production line. This note listed the production definition of all 8-bit MCU for order or obtain information. This definition is only for Blank OTP MCU.

## 17.2 MARKING INDETIFICATION SYSTEM

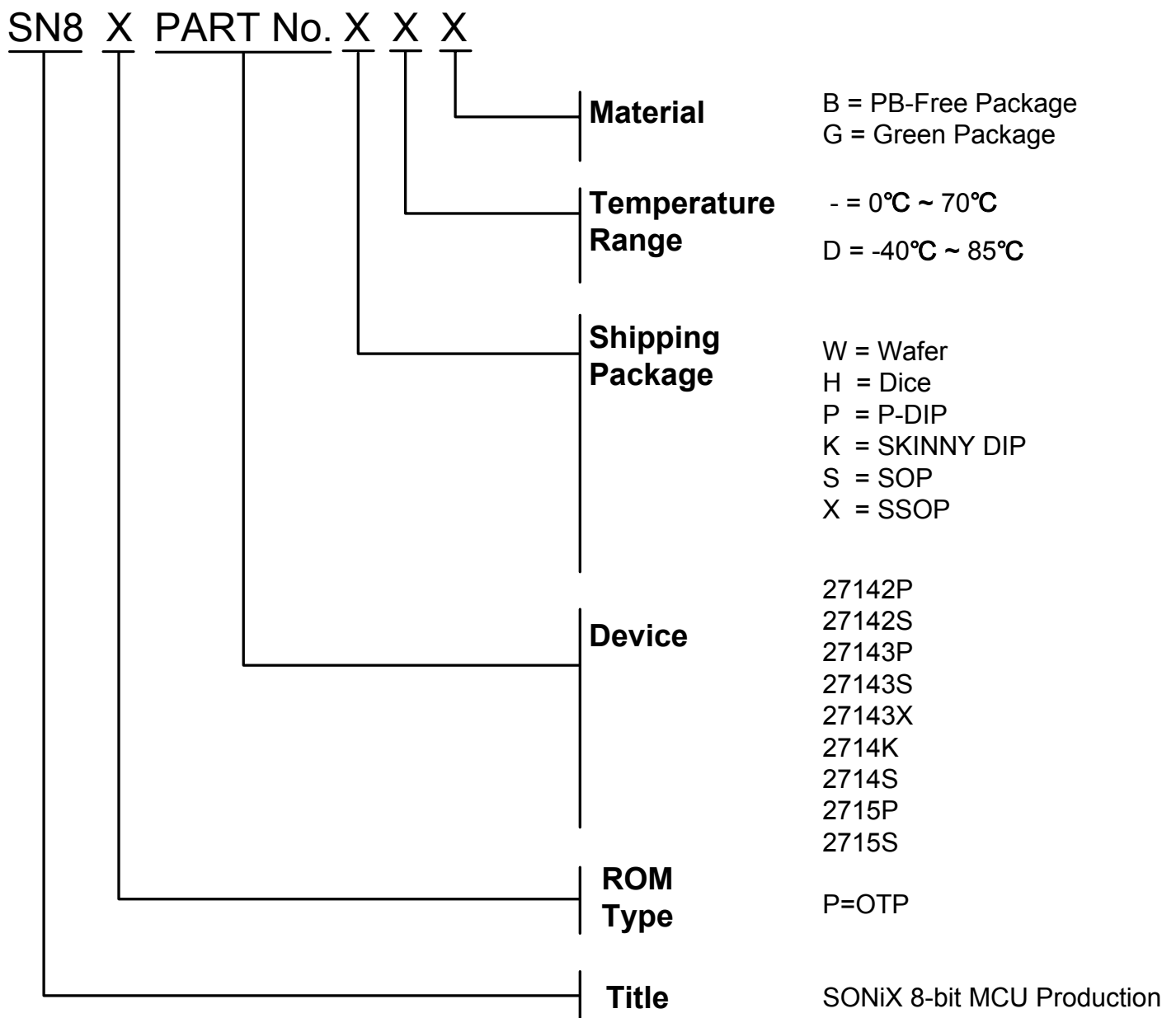



## 17.3 MARKING EXAMPLE

Name	ROM Type	Device	Package	Temperature	Material
SN8P27142PDG	OTP	27142	P-DIP	-40°C~85°C	Green Package
SN8P2624SB	OTP	2624	SOP	0°C~70°C	PB-Free Package
SN8P1907H	OTP	1907	Dice	0°C~70°C	N/A
SN8A1708AX	Mask	1708A	SSOP	0°C~70°C	N/A

➤ **Note:** Industrial Level production didn't support Wafer or Dice shipping type.

## 17.4 DATECODE SYSTEM

There are total 8~9 letters of SONiX datecode system. The final four or five char. are for Sonix inside use only, and the first 4 indicate the Package date including Year/Month/Date. The detail information is following:

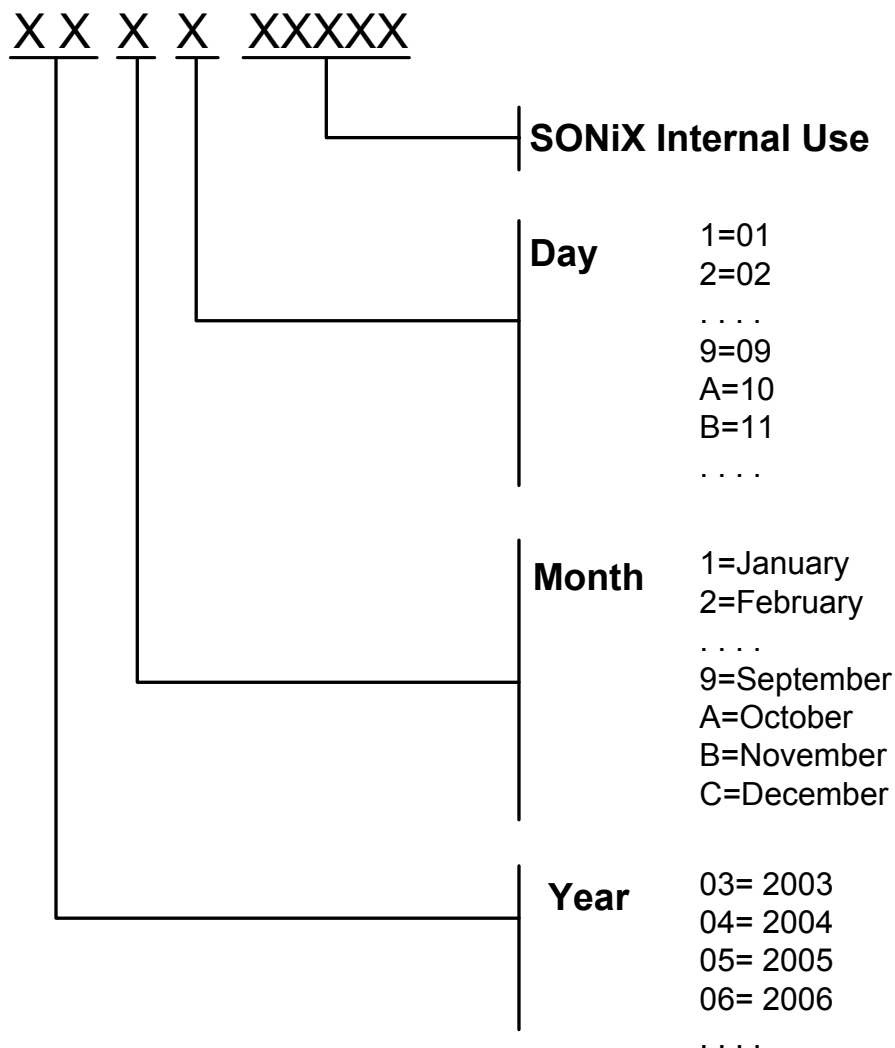

# 18 PACKAGE INFORMATION

## 18.1 P-DIP18 PIN

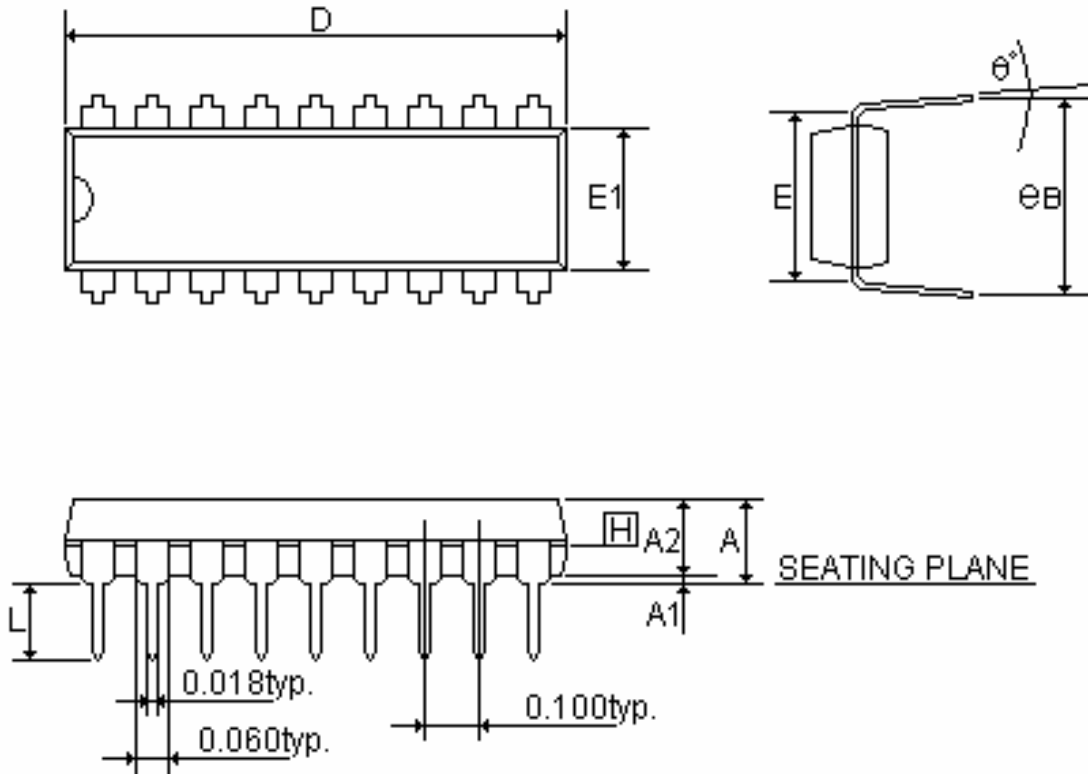

Symbols	MIN.	NOR.	MAX.
A	-	-	0.210
A1	0.015	-	-
A2	0.125	0.130	0.135
D	0.880	0.900	0.920
E	0.300BSC.		
E1	0.245	0.250	0.255
L	0.115	0.130	0.150
eB	0.335	0.355	0.375
$\theta^\circ$	0	7	15

UNIT : INCH

## 18.2 SOP18 PIN

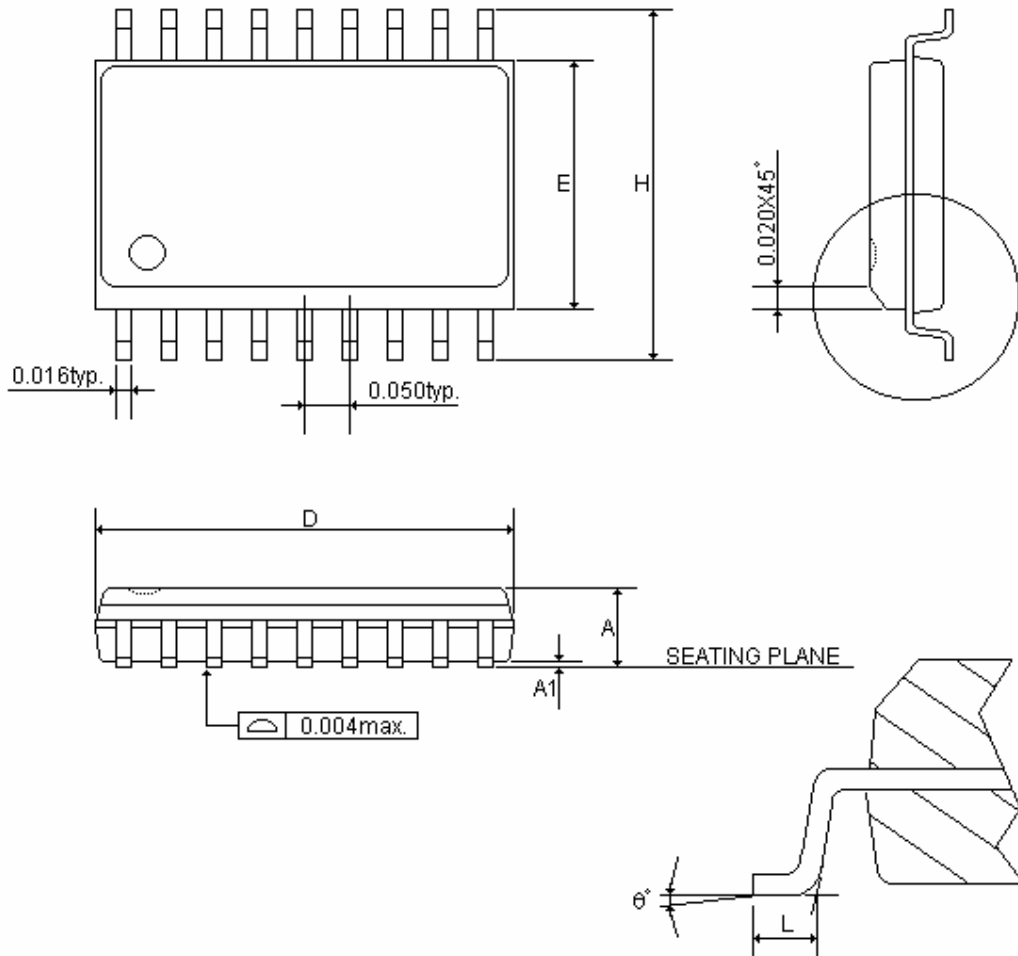

Symbols	MIN.	MAX.
A	0.093	0.104
A1	0.004	0.012
D	0.447	0.463
E	0.291	0.299
H	0.394	0.419
L	0.016	0.050
$\theta^\circ$	0	8

UNIT : INCH

## 18.3 P-DIP 20 PIN

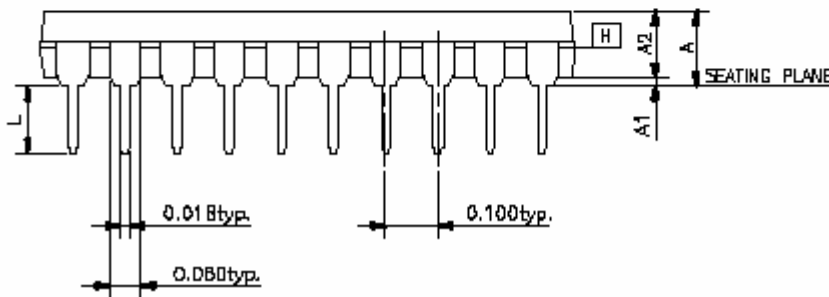
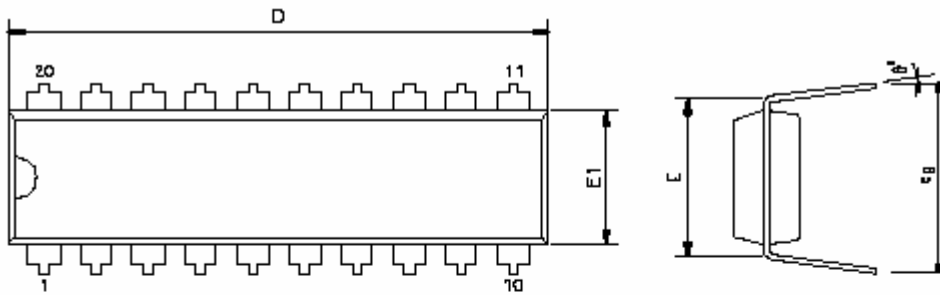

SYMBOLS	MIN.	NOR.	MAX.
A	—	—	0.210
A1	0.015	—	—
A2	0.125	0.130	0.135
D	0.98	1.030	1.060
E	0.300 BSC.		
E1	0.245	0.250	0.255
L	0.115	0.130	0.150
e <sub>B</sub>	0.335	0.355	0.375
θ	0	7	15

UNIT : INCH

**NOTES:**

1. JEDEC OUTLINE : MS-001 AD
2. "D", "E1" DIMENSIONS DO NOT INCLUDE MOLD FLASH OR PROTRUSIONS. MOLD FLASH OR PROTRUSIONS SHALL NOT EXCEED .010 INCH.
3. e<sub>B</sub> IS MEASURED AT THE LEAD TIPS WITH THE LEADS UNCONSTRAINED.
4. POINTED OR ROUNDED LEAD TIPS ARE PREFERRED TO EASE INSERTION.
5. DISTANCE BETWEEN LEADS INCLUDING DAM BAR PROTRUSIONS TO BE .005 INCH MINIMUM.
6. DATUM PLANE [H] COINCIDENT WITH THE BOTTOM OF LEAD, WHERE LEAD EXITS BODY.

## 18.4 SOP 20 PIN

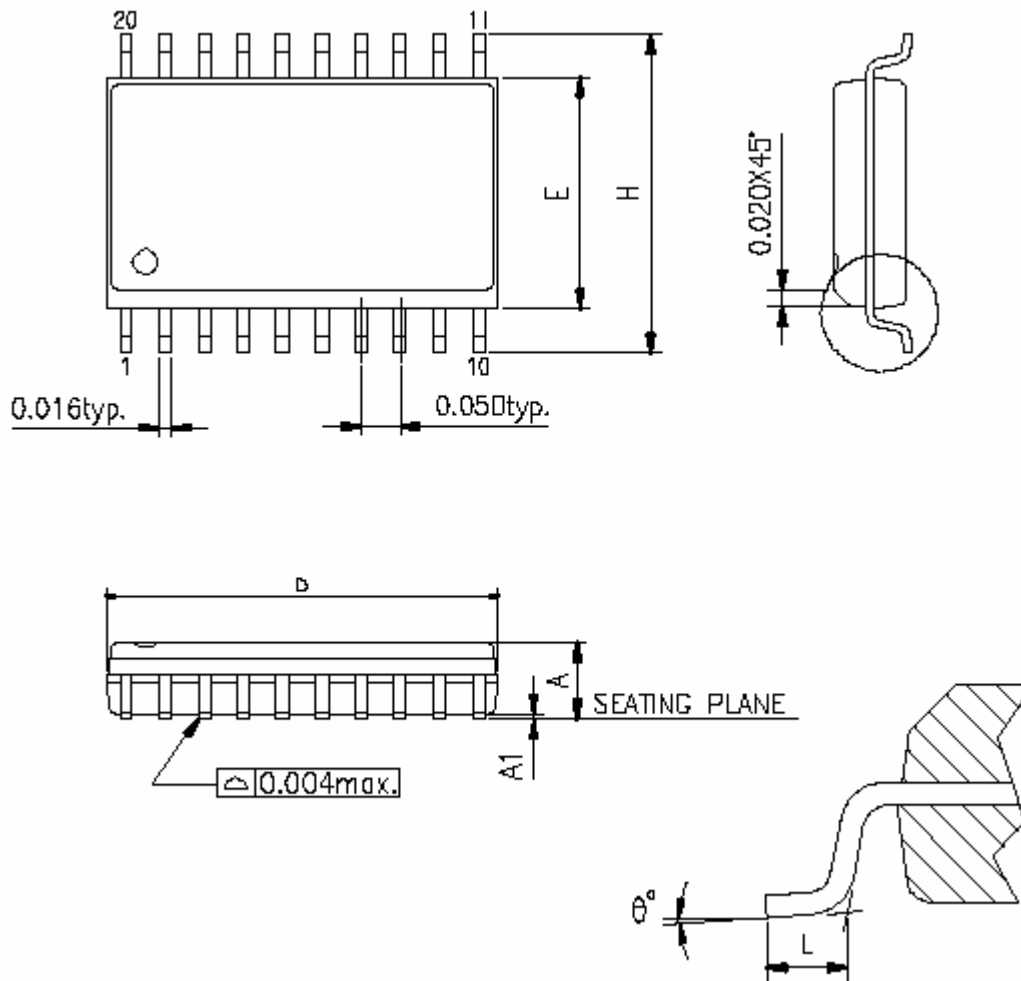

SYMBOLS	MIN.	MAX.
A	0.093	0.104
A1	0.004	0.012
D	0.496	0.508
E	0.291	0.299
H	0.394	0.419
L	0.016	0.050
$\theta^\circ$	0	8

UNIT : INCH

**NOTES:**

1. JEDEC OUTLINE : MS-013 AC
2. DIMENSIONS "D" DOES NOT INCLUDE MOLD FLASH, PROTRUSIONS OR GATE BURRS. MOLD FLASH, PROTRUSIONS AND GATE BURRS SHALL NOT EXCEED .15mm (.006in) PER SIDE.
3. DIMENSIONS "E" DOES NOT INCLUDE INTER-LEAD FLASH, OR PROTRUSIONS. INTER-LEAD FLASH AND PROTRUSIONS SHALL NOT EXCEED .25mm (.010in) PER SIDE.

## 18.5 SSOP20 PIN

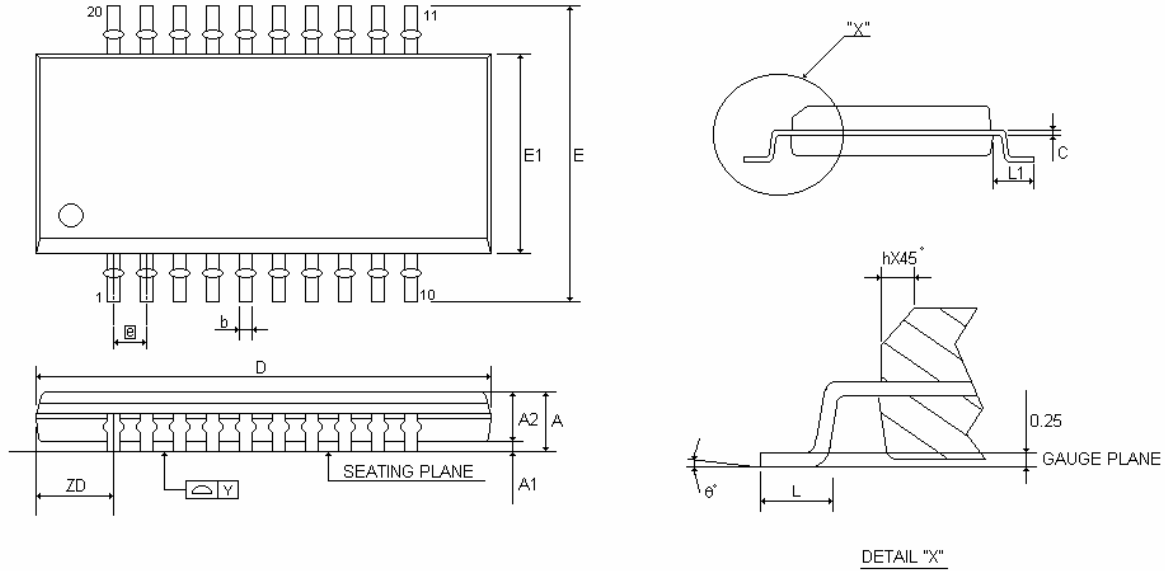

Symbols	DIMENSION (MM)			DIMENSION (MIL)		
	MIN.	NOM.	MAX.	MIN.	NOM.	MAX.
A	1.35	1.60	1.75	53	63	69
A1	0.10	0.15	0.25	4	6	10
A2	-	-	1.50	-	-	59
b	0.20	0.254	0.30	8	10	12
b1	0.20	0.254	0.28	8	11	11
C	0.18	0.203	0.25	7	8	10
C1	0.18	0.203	0.23	7	8	9
D	8.56	8.66	8.74	337	341	344
E	5.80	6.00	6.20	228	236	244
E1	3.80	3.90	4.00	150	154	157
e	0.635 BSC			25 BSC		
h	0.25	0.42	0.50	10	17	20
L	0.40	0.635	1.27	16	25	50
L1	1.00	1.05	1.10	39	41	43
ZD	1.50 REF			58 REF		
Y	-	-	0.10	-	-	4
$\theta^\circ$	0°	-	8°	0°	-	8°

## 18.6 SK-DIP28 PIN

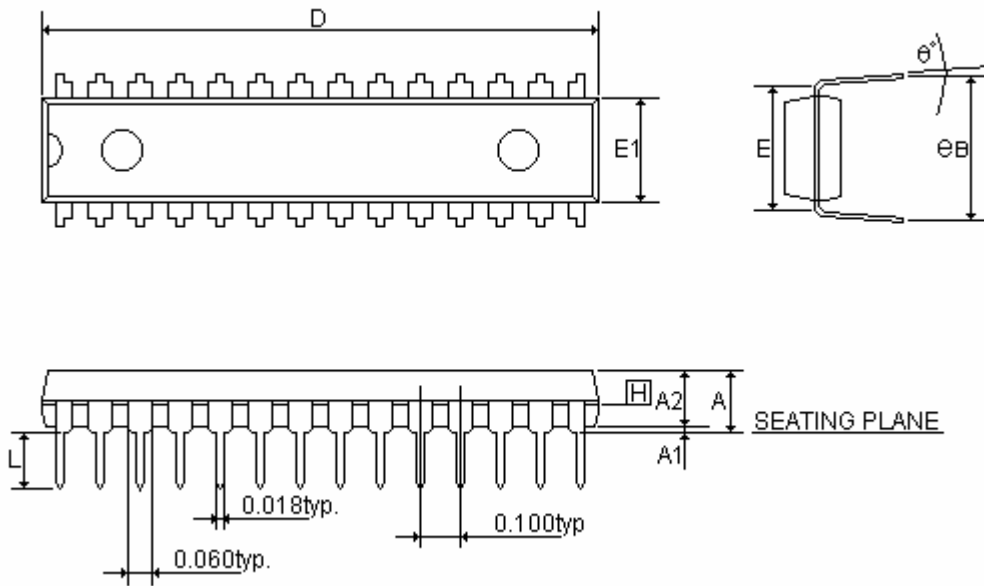

Symbols	MIN.	NOR.	MAX.
A	-	-	0.210
A1	0.015	-	-
A2	0.114	0.130	0.135
D	1.390	1.390	1.400
E	0.310BSC.		
E1	0.283	0.288	0.293
L	0.115	0.130	0.150
e <sub>B</sub>	0.330	0.350	0.370
θ°	0	7	15

UNIT : INCH

## 18.7 SOP28 PIN

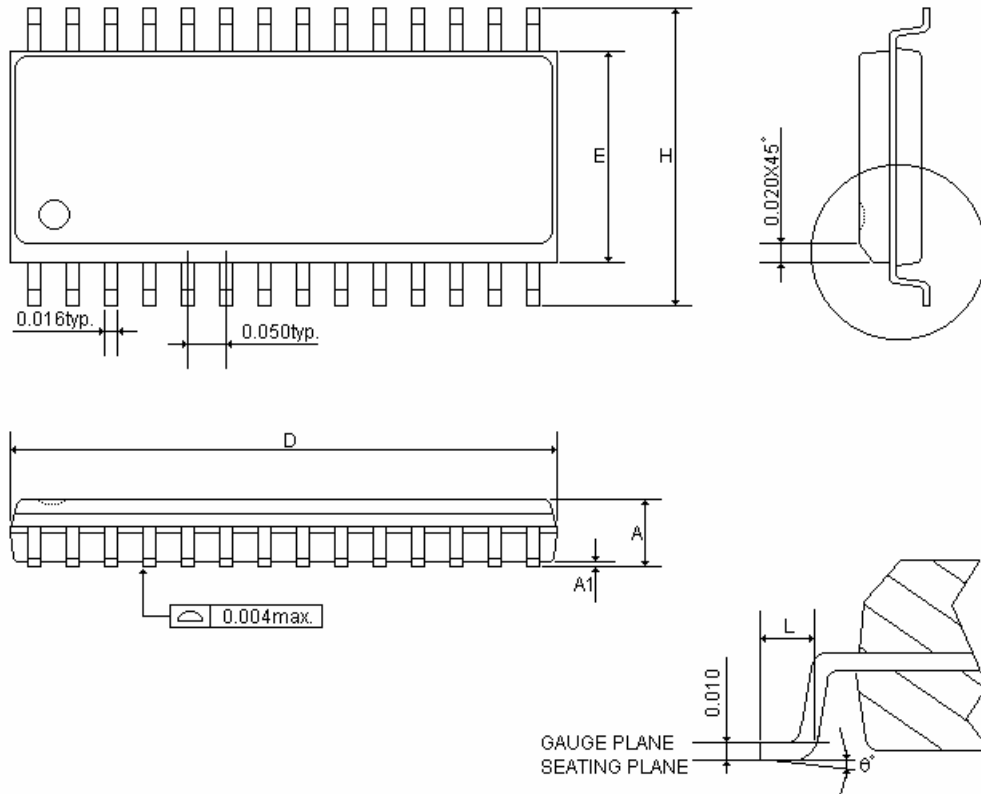

Symbols	MIN.	MAX.
A	0.093	0.104
A1	0.004	0.012
D	0.697	0.713
E	0.291	0.299
H	0.394	0.419
L	0.016	0.050
$\theta^\circ$	0	8

UNIT : INCH



## 18.8 P-DIP 32 PIN

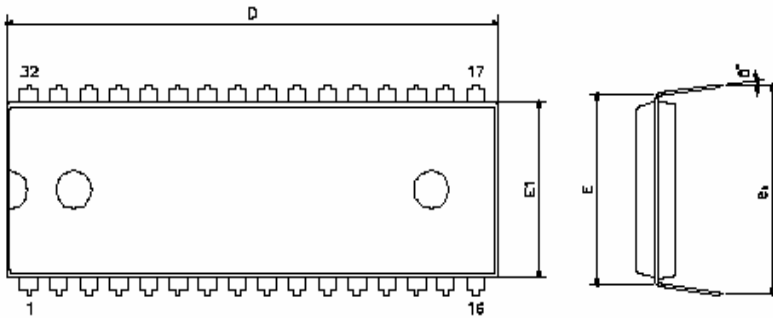

SYMBOLS	MIN.	NOR.	MAX.
A	—	—	0.220
A1	0.015	—	—
A2	0.150	0.155	0.160
D	1.645	1.650	1.660
E	0.600 BSC		
E1	0.540	0.545	0.550
L	0.115	0.130	0.150
$e_B$	0.630	0.650	0.670
$\theta^\circ$	0	7	15

UNIT : INCH

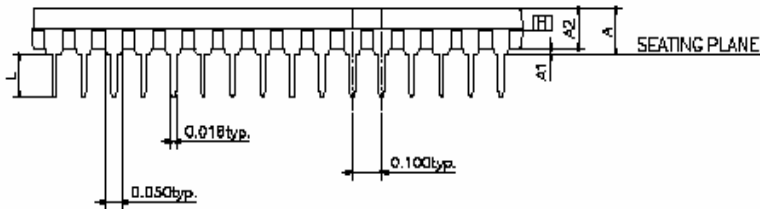

NOTE:  
1. JEDEC OUTLINE : MS-011 AC

## 18.9 SOP 32 PIN

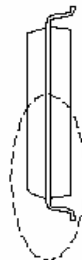
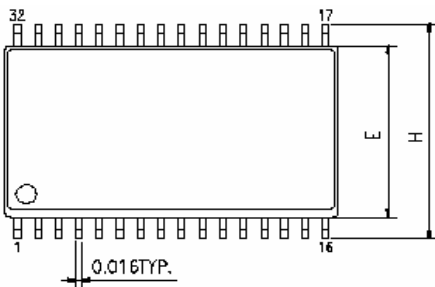

SYMBOLS	MIN.	MAX.
A	—	0.120
A1	0.004	0.014
D	0.799	0.815
E	0.437	0.450
H	0.530	0.580
L	0.016	0.050
$\theta^\circ$	0°	10°

UNIT : INCH

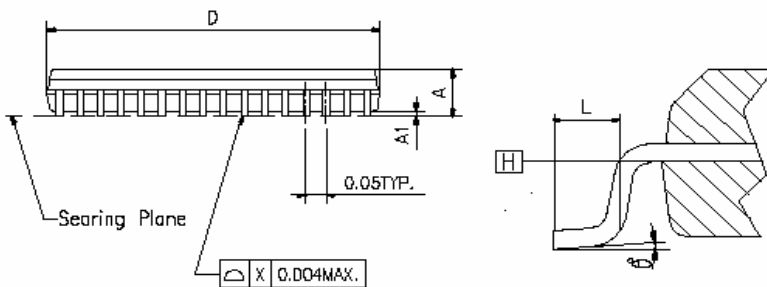

NOTE:  
1. JEDEC OUTLINE: MQ-089 AB  
2. DATUM PLANE H IS LOCATED AT THE BOTTOM OF THE MOLD PARTING LINE COINCIDENT WITH WHERE THE LEAD EXITS THE BODY.  
3. DIMENSIONS E AND D DO NOT INCLUDE MOLD PROTRUSION. ALLOWABLE PROTRUSION IS 10 MIL PER SIDE. DIMENSIONS E AND D DO INCLUDE MOLD MISMATCH AND ARE DETERMINED AT DATUM PLANE H  
4. DIMENSION b DOES NOT INCLUDE DAMBAR PROTRUSION.

SONIX reserves the right to make change without further notice to any products herein to improve reliability, function or design. SONIX does not assume any liability arising out of the application or use of any product or circuit described herein; neither does it convey any license under its patent rights nor the rights of others. SONIX products are not designed, intended, or authorized for use as components in systems intended, for surgical implant into the body, or other applications intended to support or sustain life, or for any other application in which the failure of the SONIX product could create a situation where personal injury or death may occur. Should Buyer purchase or use SONIX products for any such unintended or unauthorized application. Buyer shall indemnify and hold SONIX and its officers, employees, subsidiaries, affiliates and distributors harmless against all claims, cost, damages, and expenses, and reasonable attorney fees arising out of, directly or indirectly, any claim of personal injury or death associated with such unintended or unauthorized use even if such claim alleges that SONIX was negligent regarding the design or manufacture of the part.

**Main Office:**

Address: 9F, NO. 8, Hsien Cheng 5th St, Chupei City, Hsinchu, Taiwan R.O.C.  
Tel: 886-3-551 0520  
Fax: 886-3-551 0523

**Taipei Office:**

Address: 15F-2, NO. 171, Song Ted Road, Taipei, Taiwan R.O.C.  
Tel: 886-2-2759 1980  
Fax: 886-2-2759 8180

**Hong Kong Office:**

Address: Flat 3 9/F Energy Plaza 92 Granville Road, Tsimshatsui East Kowloon.  
Tel: 852-2723 8086  
Fax: 852-2723 9179

**Technical Support by Email:**

Sn8fae@sonix.com.tw