

### 3mm Advanced Super Flux LEDs

#### 31-01-B14-S3NC-C6T1U1DH-AM

**Lead (Pb) Free Product- RoHS Compliant**

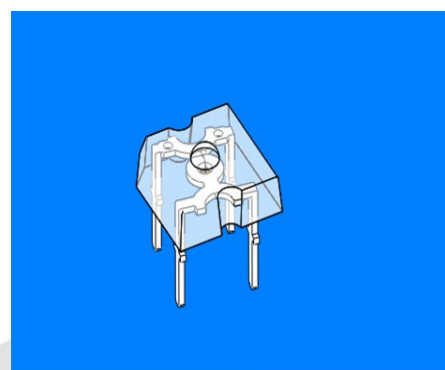

#### Feature

- Piranha package.
- Colorless clear resin.
- Low thermal resistance.
- Packaged in tubes for Automatic Insertion Equipment.
- Total Flux: 7150 to 14250 mcd at 70mA.
- Qualification according to AEC-Q101.

#### Applications

- Automotive exterior lighting: Turn light, tail light, rear-view mirror light, side light, license light switch, 3<sup>rd</sup> braking light...etc.
- Substitution of traditional light.
- Electronic Signs and Signals.
- General applications.

#### Device Selection Guide

LED Part No.	Chip	Emitted Color	Resin Color
	Material		
31-01-B14-S3NC-C6T1U1DH-AM	AlGaInP	Sunset Orange	Water Clear

<b>Table of Content</b>	<b>Page</b>
Product Nomenclature	3
Absolute Maximum Ratings (Ta=25 )	4
Electro-Optical Characteristics (Ta=25 )	5
Bin Range of Forward Voltage (Ta=25 )	6
Bin Range of Dominant Wavelength (Ta=25 )	7
Bin Range of Total Flux (Ta=25 )	8
Typical Electro-Optical Characteristics Curves	9
Package Dimensions	11
Label Explanation	12
Antistatic Packing Materials Tube and Standard Boxes	12
Precautions	13
Revision History	16

EVERLIGHT

**Product Nomenclature**

3	1	-	01	-	B14	S3	-	N	C	-	C6	T1U1	D	H	-	AM
1			2		3	4		5	6		7	8	9	10		11

The product name is designated as below:

1.	Product type
2.	Lead-frame type
3.	Angle
4.	Product pasted without Zener
5.	Chip code
6.	Resin color
7.	Wavelength
8.	Power & Total Flux
9.	Range of Forward Voltage specification
10.	Operation current
11.	Application

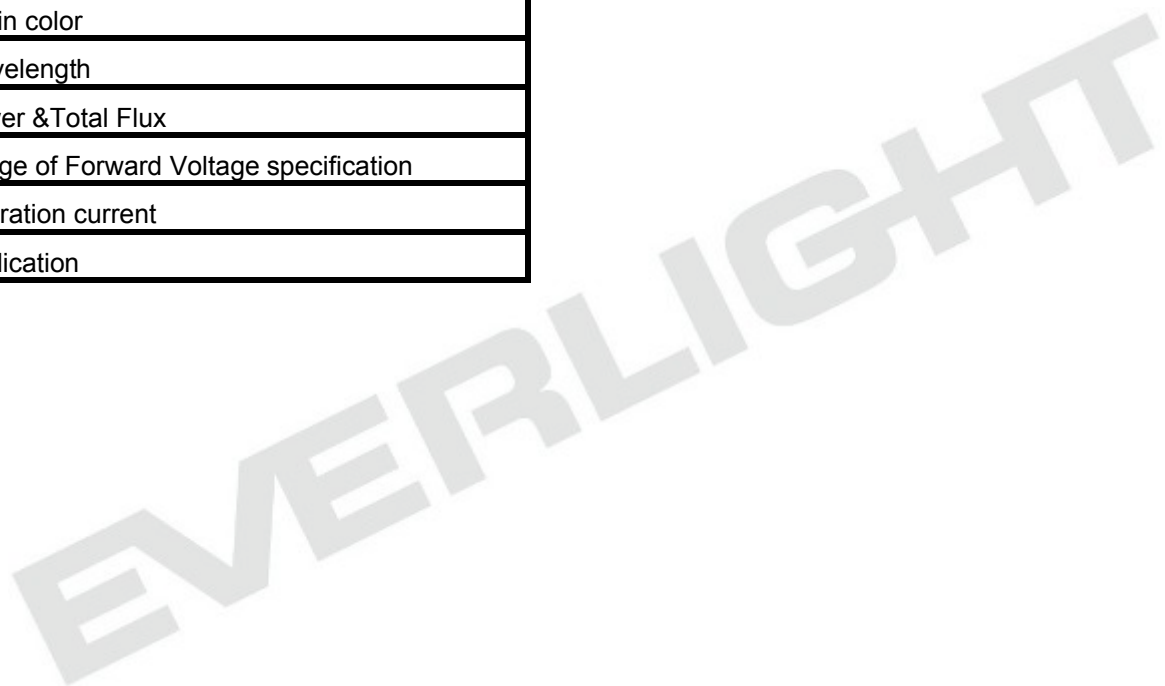

**Absolute Maximum Ratings (Ta=25 )**

Parameter	Symbol	Rating	Unit
Reverse Voltage	$V_R$	12	V
Continuous Forward Current	$I_F$	70	mA
Peak Forward Current (Duty 1/10 @1KHz)	$I_{FP}$	150	mA
Power Dissipation	$P_d$	220	mW
LED Junction Temperature	$T_j$	120	
Operating Temperature	$T_{opr}$	-40 ~ +100	
Storage Temperature	$T_{stg}$	-40 ~ +100	
Thermal Resistance	$R_{th J-A}$	150	K/M
Electrostatic Discharge	$ESD_{HBM}$	2000	V
	$ESD_{MM}$	200	
Soldering Temperature(T=5 sec)	$T_{sol}$	260 ± 5	

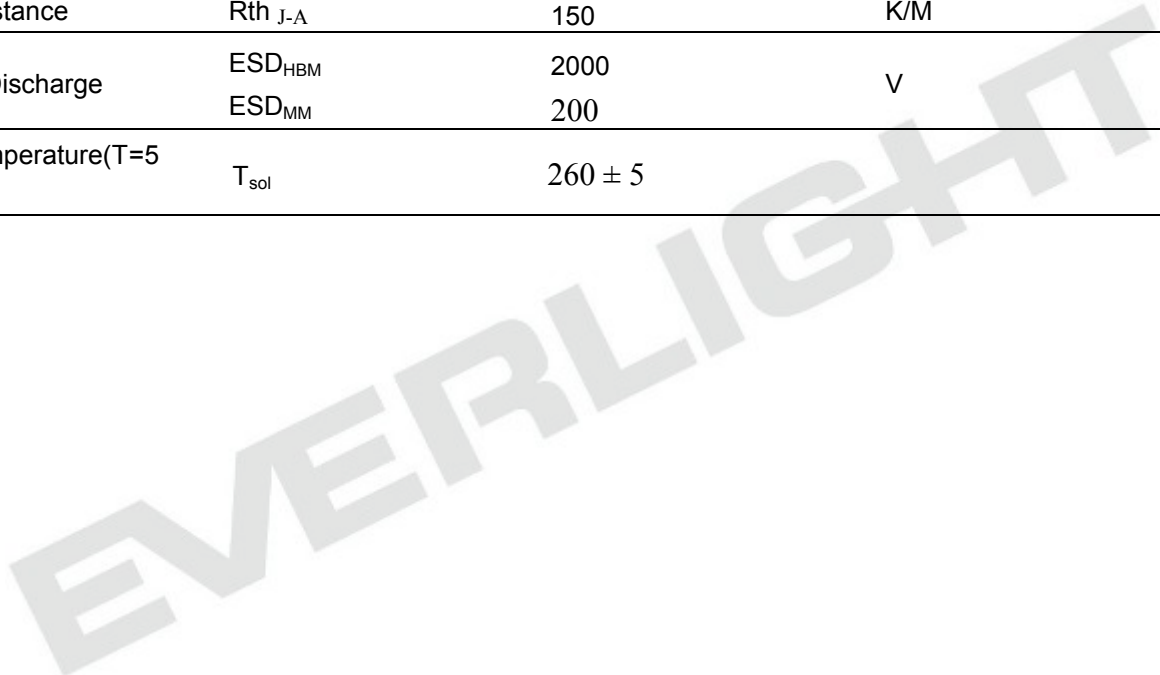

**Electro-Optical Characteristics (Ta=25 )**

Parameter	Symbol	Min.	Typ.	Max.	Unit	Condition
Total Flux	$\phi_v$	7150	---	14250	mlm	$I_F = 70\text{mA}$
Peak Wavelength	$\lambda_p$	----	621	----	nm	$I_F = 70\text{mA}$
Dominant Wavelength	$\lambda_d$	611	----	620	nm	$I_F = 70\text{mA}$
Spectrum Radiation Bandwidth	$\Delta\lambda$	----	18	----	nm	$I_F = 70\text{mA}$
Viewing Angle	$2\theta_{1/2}$	----	50	----	deg	$I_F = 70\text{mA}$
Forward Voltage	$V_F$	1.9	----	2.9	V	$I_F = 70\text{mA}$
Reverse Current	$I_R$	----	----	10	$\mu\text{A}$	$V_R = 5\text{V}$

Note:

1. Total Flux:  $\pm 11\%$
2. Tolerance of Dominant Wavelength:  $\pm 1\text{nm}$
3. Tolerance of Forward Voltage:  $\pm 0.1\text{V}$



### Bin Range of Forward Voltage

Bin	Min.	Max.	Unit	Condition
1	1.9	2.1	V	$I_F = 70\text{mA}$
2	2.1	2.3		
3	2.3	2.5		
4	2.5	2.7		
5	2.7	2.9		

Note:

Tolerance of Forward Voltage:  $\pm 0.1\text{V}$

EVERLIGHT

### Bin Range of Dominant Wavelength

Bin	Min.	Max.	Unit	Condition
2	611	614	nm	I <sub>F</sub> =70mA
3	614	617		
4	617	620		

Note:

Tolerance of Dominant Wavelength: ±1nm

EVERLIGHT

### Bin Range of Total Flux

Bin	Min.	Max.	Unit	Condition
T1	7150	9000	mlm	$I_F = 70\text{mA}$
T2	9000	11250		
U1	11250	14250		

Note:

Tolerance of Total Flux:  $\pm 11\%$

EVERLIGHT



**Typical Electro-Optical Characteristics Curves**

**Typical Curve of Spectral Distribution**

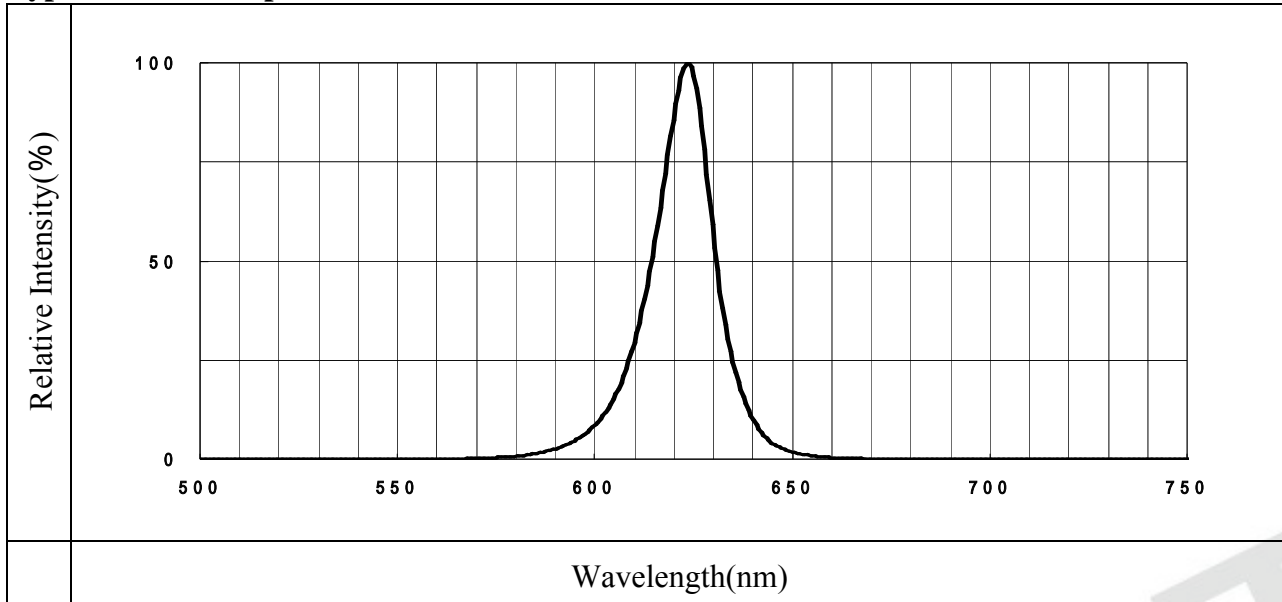

Note:  $V(\lambda)$ =Standard eye response curve;  $I_F = 20\text{mA}$

**Diagram Characteristics of Radiation**

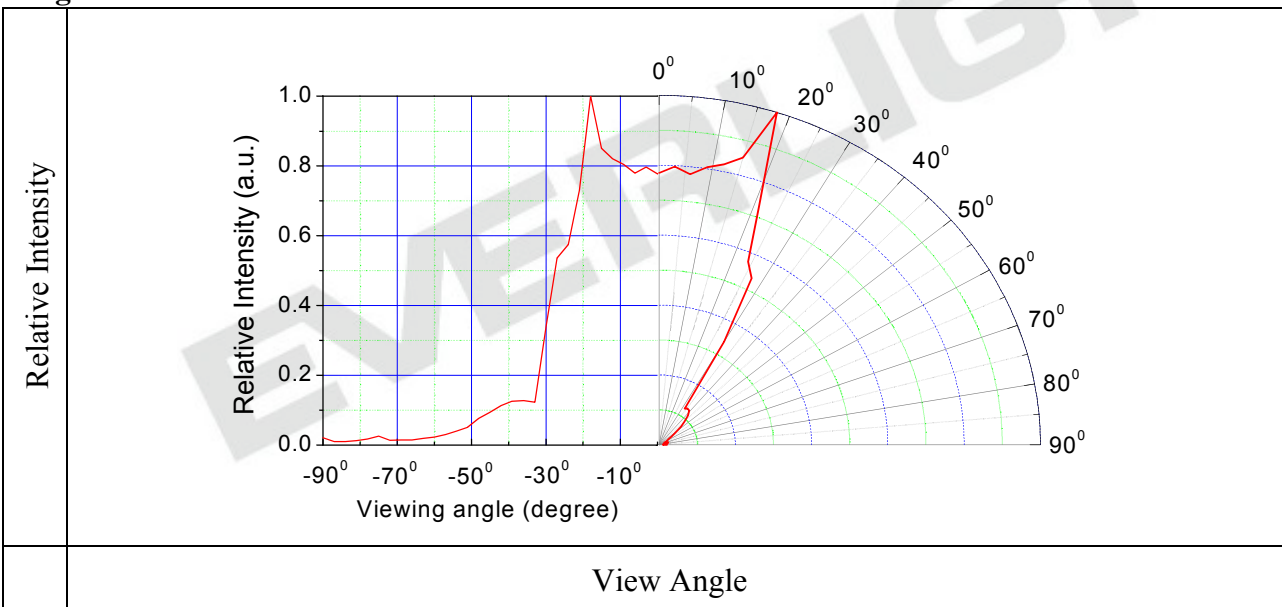

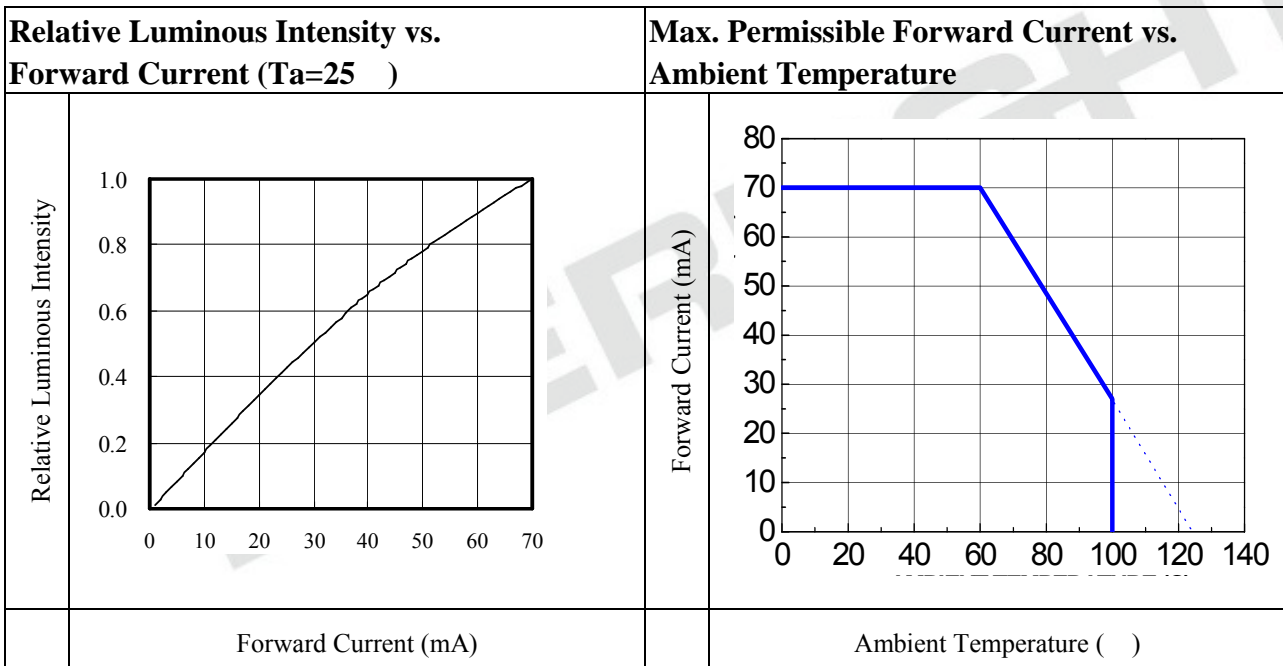
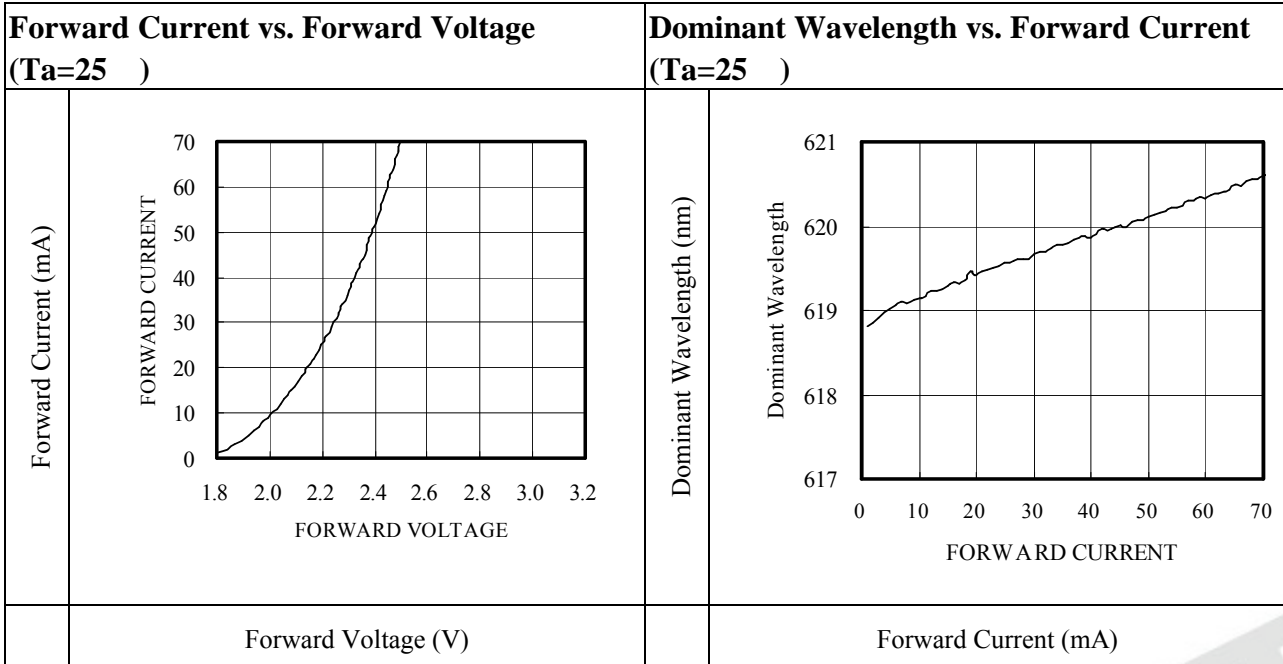

### Package Dimension

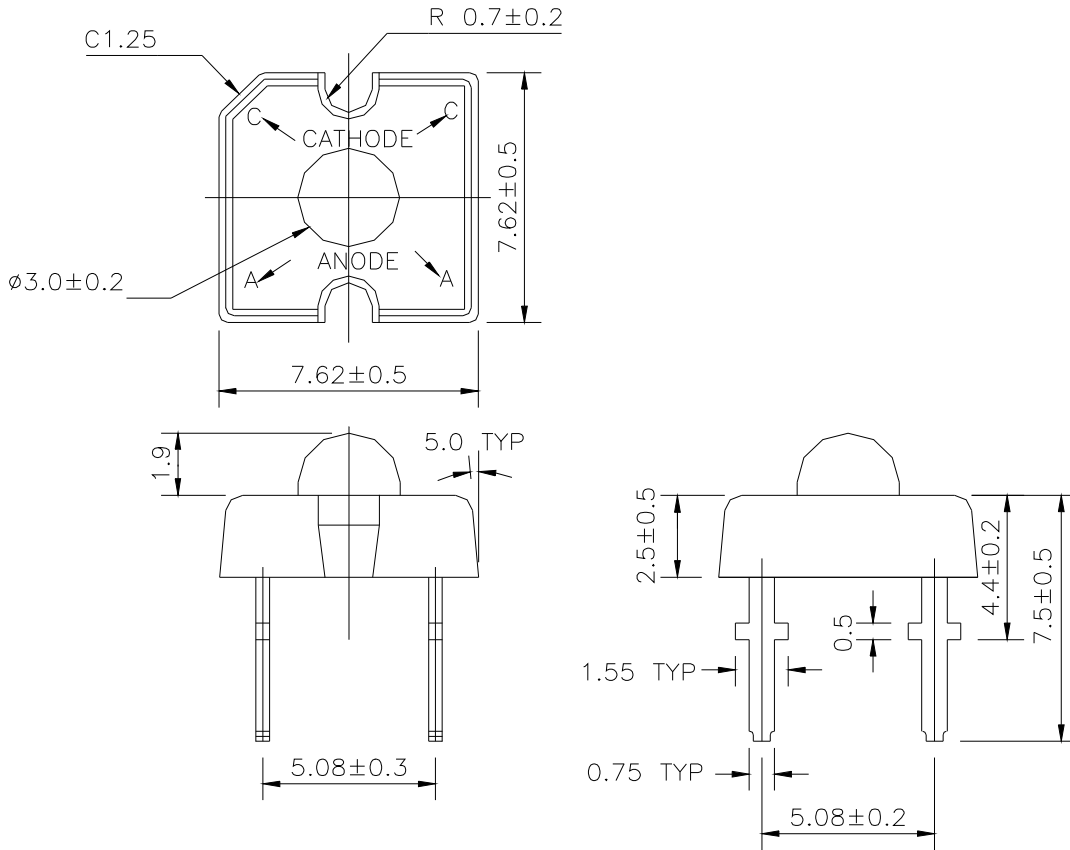

Note: 1. Tolerances unless mentioned  $\pm 0.25$  mm. Unit = mm

2. An epoxy meniscus may extend about 1.5 mm (0.059") down the leads

## Antistatic Packing Materials

### Tube

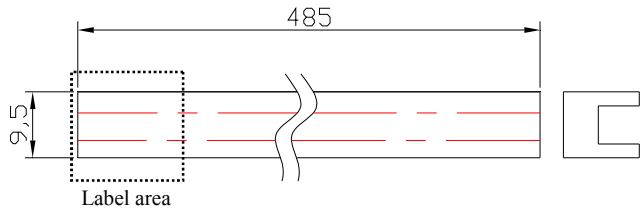

#### Inner Label Explanation

- QTY: Packing Quantity
- LOT No: Lot Number
- CAT: Rank of (VF)(Note\*)(ΦV)  
Note:  $\lambda_d$ /CIE/Color temperature

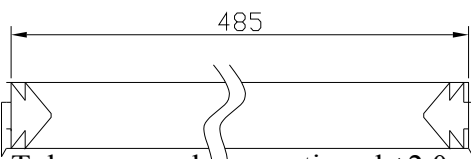

Note: Tolerances unless mentioned  $\pm 2.0\text{mm}$ . Unit = mm

### Standard Box

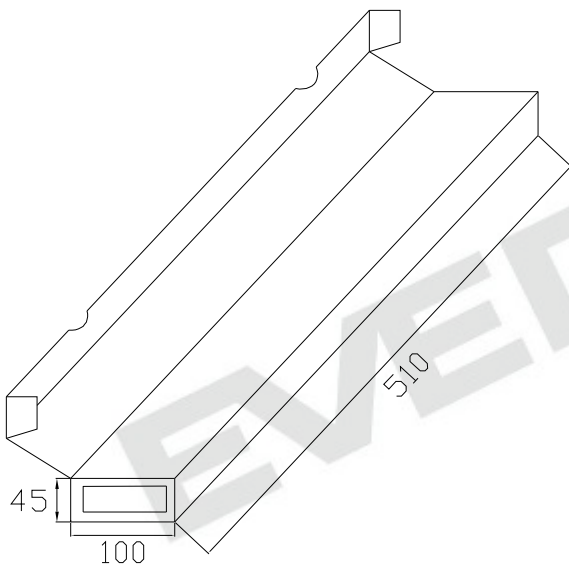

#### Out Lable Explanation

- CPN: Customer's Product Number
- P/N: Product Number
- QTY: Packing Quantity
- CAT: Rank of (VF)(Note\*)(ΦV)
- Note:  $\lambda_d$ /CIE/Color temperature
- HUE/REF: Reference
- LOT No: Lot Number

Note: Tolerances unless mentioned  $\pm 3.0\text{mm}$ . Unit = mm

### Packing Quantity

Packing material	Length × Width × height (mm)	Tube Quantity (Pcs)	LED Quantity (Pcs)
Tube	485 x 9.5 x12	1	60
Standard box	510 x 100 x 45	30	1800
Large box	510 x 150 x 90	105	6300

Note:

1. Normal packing specification is use standard box, unless already defined initially.
2. Vacuum packing with anti-static bag after packing in standard box.
3. Specifications are subject to change without prior notice.

Notes

#### 1. Lead Forming

- During lead formation, the leads should be bent at a point at least 3mm from the base of the epoxy bulb.
- Lead forming should be done before soldering.
- Avoid stressing the LED package during leads forming. The stress to the base may damage the LED's characteristics or it may break the LEDs.
- Cut the LED leadframes at room temperature. Cutting the leadframes at high temperatures may cause failure of the LEDs.
- When mounting the LEDs onto a PCB, the PCB holes must be aligned exactly with the lead position of the LED. If the LEDs are mounted with stress at the leads, it causes deterioration of the epoxy resin and this will degrade the LEDs.

#### 2. Storage

- The LEDs should be stored at 30°C or less and 70%RH or less after being shipped from Everlight and the storage life limits are 3 months. If the LEDs are stored for 3 months or more, they can be stored for a year in a sealed container with a nitrogen atmosphere and moisture absorbent material.
- Please avoid rapid transitions in ambient temperature, especially, in high humidity environments where condensation can occur.

#### 3. Soldering

- Careful attention should be paid during soldering. Solder the LED no lower than 1.6mm from the base of stopper is recommended.
- Avoiding applying any stress to the lead frame while the LEDs are at high temperature particularly when soldering.
- Recommended soldering conditions:

Hand Soldering		DIP Soldering	
Temp. at tip of iron	300 Max. (30W Max.)	Preheat temp.	100 Max. (60 sec Max.)
Soldering time	3 sec Max.	Bath temp.	260 Max.
Distance	No lower than 1.6mm from the base of stopper	Bath time.	5 sec Max.
		Distance	No lower than 1.6mm from the base of stopper

- Dip and hand soldering should not be done more than one time.
  - After soldering the LEDs, the epoxy bulb should be protected from mechanical shock or vibration until the LEDs return to room temperature.
  - A rapid-rate process is not recommended for cooling the LEDs down from the peak temperature.
  - Although the recommended soldering conditions are specified in the above table, dip or handsoldering at the lowest possible temperature is desirable for the LEDs.
  - Wave soldering parameter must be set and maintain according to recommended temperature and dwell time in the solder wave.
4. Cleaning
- When necessary, cleaning should occur only with isopropyl alcohol at room temperature for a duration of no more than one minute. Dry at room temperature before use.
  - Do not clean the LEDs by the ultrasonic. When it is absolutely necessary, the influence of ultrasonic cleaning on the LEDs depends on factors such as ultrasonic power and the assembled condition. Ultrasonic cleaning shall be pre-qualified to ensure this will not cause damage to the LED
5. Heat Management
- Heat management of LEDs must be taken into consideration during the design stage of LED application. The current should be de-rated appropriately by referring to the de-rating curve found in each product specification.
  - The temperature surrounding the LED in the application should be controlled. Please refer to the data sheet de-rating curve.
6. ESD (Electrostatic Discharge)
- Electrostatic discharge (ESD) or surge current (EOS) can damage LEDs.
  - An ESD wrist strap, ESD shoe strap or antistatic gloves must be worn whenever handling LEDs.
  - All devices, equipment and machinery must be properly grounded.
  - Use ion blower to neutralize the static charge which might have built up on surface of the LEDs plastic lens as a result of friction between LEDs during storage and handing.

7. Other

- Above specification may be changed without notice. EVERLIGHT will reserve authority on material change for above specification.
- When using this product, please observe the absolute maximum ratings and the instructions for using outlined in these specification sheets. EVERLIGHT assumes no responsibility for any damage resulting from use of the product which does not comply with the absolute maximum ratings and the instructions included in these specification sheets.
- These specification sheets include materials protected under copyright of EVERLIGHT corporation. Please don't reproduce or cause anyone to reproduce them without EVERLIGHT's consent.

EVERLIGHT

### Revision History

Rev.	Modified date	File modified contents
3	2013/5/24	Change the form of datasheet

EVERLIGHT