

MD3802/3805/3810

2/5/10MHz V/F, F/V Converters

Models MD3802/3805/3810 are high-performance, precision 2/5/10MHz full-scale voltage-to-frequency converters, intended for those applications that require maximum performance at the most economical cost. These converters feature >126/134/142-dB dynamic range, $\pm 0.01/0.02/0.05\%$ linearity, and $\pm 5\%$ overrange capability.

All models accept a $-100\mu\text{V}$ to -10V full-scale analog input signal that is converted to an output signal whose frequency is proportional to the full-scale frequency within $\pm 0.01/0.02/0.05\%$ linearity, using the long-proven charge-balance technique. The devices offer buffered complementary TTL-compatible frequency outputs that will drive capacitive loads as high as 50 pF .

Models MD3802/3805/3810, in addition to functioning as V/F converters, can also be used as F/V converters. In this configuration, the converters will accept frequencies from dc to 2/5/10MHz and will produce proportional single-ended output voltages from 0V to -10V .

In applications where overall system throughput must be maintained at a specific rate, or where fixed offset or different scale voltages would be more convenient, custom frequencies and/or custom trimming can be easily accommodated. By increasing the full-scale output frequency by 10 to 20%, for example, additional time would be available for the system microprocessor to access the results of each conversion. Please contact the factory to discuss your specific timing requirements.

All models are packaged in a $1.31'' \times 0.80'' \times 0.15''$ 24-pin ceramic DIL package. Power dissipation is lower than $0.75/0.85/1.0$ watts, and operation to specified accuracy is guaranteed over the 0°C to $+70^\circ\text{C}$ temperature range.

Features:

- **Guaranteed Minimum/Maximum Specifications**
- **Wide Dynamic Range**
>2,000,000/5,000,000/
10,000,000:1
>126/134/142 dB
- **Excellent Linearity**
 $\pm 0.01/0.02/0.05\%$ FSR
 $\pm 0.01/0.02/0.05\%$ of Input
- **Excellent Stability**
10 $\mu\text{V}/^\circ\text{C}$ Offset
75 ppm/ $^\circ\text{C}$ Gain
- **Voltage or Current Inputs**
- **Offset and Gain Error Trimmable to Zero**
- **Complementary Frequency Outputs-TTL/CMOS Compatible**
- **Small 24-Pin DIP**
- **Low Power <0.75/0.85/1.0W**

Applications:

- **Precision Integration**
- **Digital Data Transmission**
- **Frequency Synthesis**
- **Analytical Instrumentation**
- **Medical Instrumentation**
- **Telemetry**
- **Data Recording**
- **Weighing Systems**
- **Tachometers**
- **Accelerometers**
- **Flow Meters**
- **Robotics**

For additional information regarding Custom Microelectronic Products and Services, please contact Micro Networks at:



micro networks corporation

324 Clark St., Worcester, MA 01606
Tel. (508) 852-5400 • FAX (508) 853-8296
E-Mail – sales@mnc.com
Web Site – <http://www.mnc.com>

MD3802/3805/3810

2/5/10MHz V/F, F/V Converters

Absolute Maximum Ratings

Operating Temperature Range	0°C to +70°C
Storage Temperature Range	-65°C to +150°C
+15V Supply (Pin 1)	+15.45 Volts
-15V Supply (Pin 5)	-15.45 Volts
+5V Supply (Pin 20)	+5.25 Volts
Analog Input (Pin 11)	-15 Volts to +15 Volts

Ordering Information

Part Number	MD3802	MD3805	MD3810
2MHz Full-scale	_____		
5MHz Full-scale	_____		
10MHz Full-scale	_____		

Specifications

Specifications @ $T_A = +25^\circ\text{C}$, Supplies = $\pm 15\text{V}$ and $+5\text{V}$, unless otherwise indicated

		Min.	Typ.	Max.	Units
ANALOG INPUTS					
Input Voltage Range			0 to -10		Volts
Nonsaturating Overrange		5			%
Configuration			Single-Ended		
Input Impedance	MD3802		15		k Ω
	MD3805		10		k Ω
	MD3810		5		k Ω
Offset Voltage (trimmable to zero)			± 7	± 10	mV
TRANSFER CHARACTERISTICS					
Full-Scale Output	MD3802	2			MHz
	MD3805	5			MHz
	MD3810	10			MHz
Transfer Function	MD3802		2MHz $\cdot(V_{IN}/10\text{V})$		
	MD3805		5MHz $\cdot(V_{IN}/10\text{V})$		
	MD3810		10MHz $\cdot(V_{IN}/10\text{V})$		
Gain Error (trimmable to zero)				± 1	%
Nonlinearity (max.) (not specified under overrange conditions)	MD3802		$\pm 0.01\% \text{FS} \pm 0.01\% V_{IN}$		
	MD3805		$\pm 0.02\% \text{FS} \pm 0.02\% V_{IN}$		
	MD3810		$\pm 0.05\% \text{FS} \pm 0.05\% V_{IN}$		
Full-Scale Step Response (maximum; to 0.01%)	MD3802		2 cycles of new $f_{OUT} + 20\mu\text{sec}$		
	MD3805		2 cycles of new $f_{OUT} + 10\mu\text{sec}$		
	MD3810		2 cycles of new $f_{OUT} + 5\mu\text{sec}$		
Overload Recovery	MD3802		8 cycles of new f_{OUT}		
	MD3805		10 cycles of new f_{OUT}		
	MD3810		12 cycles of new f_{OUT}		
STABILITY					
Gain Temperature Coefficient	MD3802		50	75	ppm of FSR/ $^\circ\text{C}$
	MD3805, MD3810		75	100	ppm of FSR/ $^\circ\text{C}$
Offset Temperature Coefficient			10	30	ppm of FSR/ $^\circ\text{C}$
Power Supply Rejection	Gain			200	ppm of FSR/%Vs
	Offset			10	$\mu\text{V}/\% \text{Vs}$
Warm-up Time (to specified accuracy)				2	Minutes
OUTPUT					
Pulse Width	MD3802	200	250	300	nsec
	MD3805	80	100	120	nsec
	MD3810	40	50	60	nsec
Logic Levels: Logic "1"		+3.5	+4.0	+4.5	Volts
Logic "0" (3 mA sink)				0.4	Volts
POWER SUPPLY REQUIREMENTS					
$\pm 15\text{V}$ Supplies		± 14.55		± 15.45	Volts
+5V Supply		+4.75		± 5.25	Volts
+15V Current Drain	MD3802			20	mA
	MD3805			25	mA
	MD3810			35	mA
-15V Current Drain				10	mA
+5V Current Drain	MD3802			45	mA
	MD3805			50	mA
	MD3810			60	mA
Power Dissipation	MD3802			750	mW
	MD3805			850	mW
	MD3810			1000	mW

Specifications subject to change without notification as Micro Networks reserves the right to make improvements and changes in its products.



micro networks corporation

324 Clark St., Worcester, MA 01606
 Tel. (508) 852-5400 • FAX (508) 853-8296
 E-Mail – sales@mnc.com
 Web Site – <http://www.mnc.com>

Block Diagram

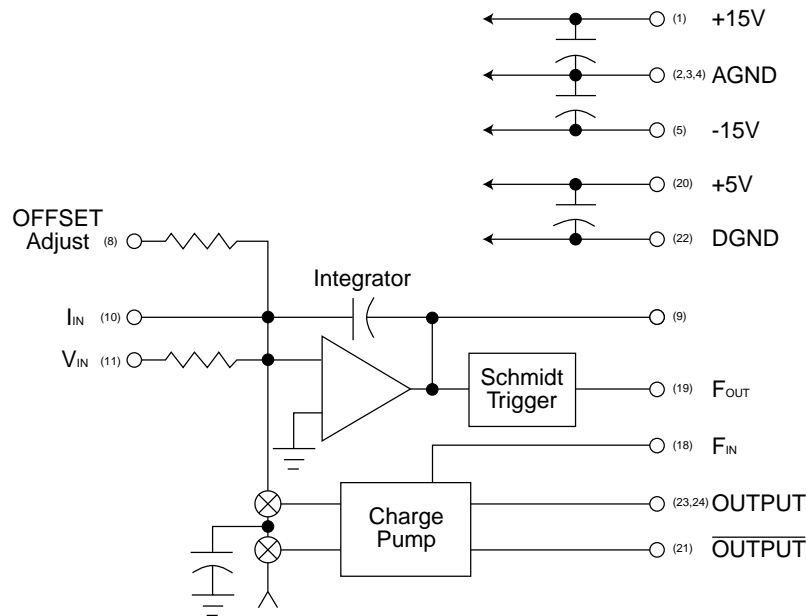

USING THE MD38XX

GENERAL CONSIDERATIONS – A typical circuit configuration for the MD38XX models used as V/F converters is depicted in Figure 2. The layout should be clean, with output pulses routed as far away from the input analog signals as possible. To obtain maximum performance, bypass capacitors, as shown in both figures, should be mounted right at the appropriate pins of the converters.

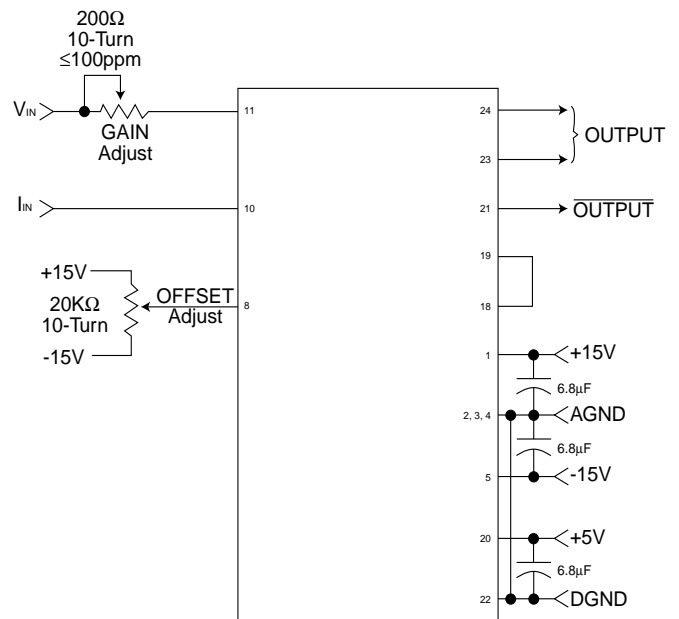

Figure 2. V/F Converter Configuration.



micro networks corporation

324 Clark St., Worcester, MA 01606
 Tel. (508) 852-5400 • FAX (508) 853-8296
 E-Mail – sales@mnc.com
 Web Site – <http://www.mnc.com>

MD3802/3805/3810

2/5/10MHz V/F, F/V Converters

OFFSET AND GAIN TRIMMING – The Offset adjustment potentiometer should be a 20 k Ω , 10-turn unit. With this pot in the circuit, initial offsets of up to ± 10 mV may be trimmed to zero.

The Gain adjustment potentiometer should be a 200 Ω , 10-turn unit. To ensure that the temperature coefficient of the potentiometer does not become significant relative to the overall gain tempco specification, a 100 ppm or better potentiometer is recommended. With this pot in the circuit, initial gain errors of up to $\pm 2\%$ may be trimmed to zero.

GROUNDING – The Analog and Digital grounds are internally separated in the MD38XX models. The use of ground plane is not necessary for proper operation of the MD38XX. However, a ground plane is recommended with any analog signal conditioning circuitry that may be used in a V/F application, especially if this circuitry involves high gains. Any amplifiers used ahead of the MD38XX should have decoupling capacitors on their power supply pins to help eliminate potential problems with the high-frequency output of the V/F.

OFFSET AND GAIN CALIBRATION

OFFSET CALIBRATION – Offset calibration should be performed prior to gain calibration. With a -1mV analog input signal at pin 11 of the MD38XX, adjust the Offset potentiometer until a frequency of 200/500/1000Hz is observed on output pins 21, 23 or 24.

GAIN CALIBRATION – With a full scale analog input voltage of -10.00V on pin 11 (MD38XX), adjust the Gain potentiometer until a full scale frequency of 2.000/5.000/10.000MHz is observed on output pin 21, 23 or 24.

N/C PINS – Pins marked as N/C (no connect) have no electric connection to the internal circuitry of the MD38XX.

OUTPUT PINS – Pins 23 and 24 are tied together internally. Either or both may be used as the source of the frequency output of the MD38XX, as long as the load specifications are not exceeded. Pin 21 provides a complementary signal relative to pins 23 and 24 with similar loading limits.

V/F MODE

ANALOG INPUTS – Single-ended analog inputs from 0 to -10V are applied to pin 11 of the V/F converter through the Gain adjustment potentiometer.

F/V MODE

Figure 3 depicts the typical circuit configuration for the MD38XX used in the F/V mode. In this mode, the MD38XX will accept a 0 to 2/5/10MHz input pulse train, with negative-going pulses, (250 \pm 50) (100 \pm 20) (50 \pm 10)nsec in width, and will produce a voltage output proportional to the input frequency. Riding on the output voltage will be a ripple voltage. Addi-



micro networks corporation

324 Clark St., Worcester, MA 01606
Tel. (508) 852-5400 • FAX (508) 853-8296
E-Mail – sales@mnc.com
Web Site – <http://www.mnc.com>

MD3802/3805/3810

2/5/10MHz V/F, F/V Converters

tional filtering of the output voltage by the use of a 2-pole active filter will reduce the output ripple as shown in Table 1. A representative 2-pole active filter circuit is shown in figure 4. Suitable component values are listed in Table 1. It is recommended that a high input impedance, low noise op amp be used, and that offset nulling be done in order to obtain accurate dc performance.

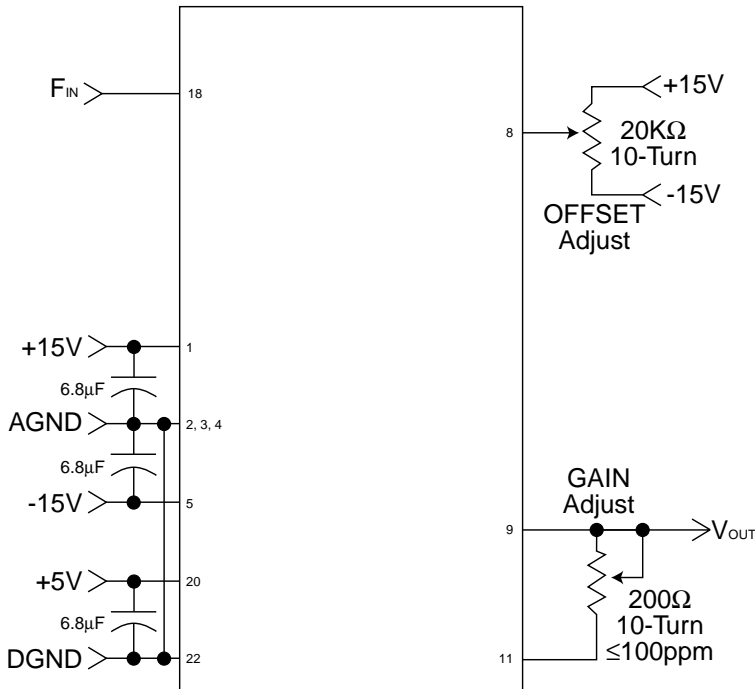

Figure 3. F/V Converter Configuration.

FcUTOFF	C1(pF)	C2(pF)	R1(kΩ)	R2(kΩ)	Output Ripple (mV)		
					MD3802	MD3805	MD3810
20 kHz	180	470	16.2	46.2	70	35	5
25 kHz	150	330	21.0	39.2	60	20	5
30 kHz	150	330	17.4	27.4	60	40	5
50 kHz	68	180	16.9	48.7	50	20	5
100 kHz	33	100	14.3	53.6	80	20	5

Table 1. Ripple Reduction By Active Filter.

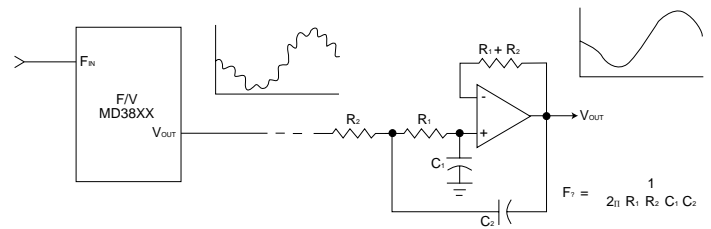

Figure 4. Typical 2-Pole Active Filter

V/F/VANALOG DATA INK – Figure 5 depicts the MD38XX used as both the V/F and F/V in an analog data link. Low-level analog data may be transmitted over considerable distances with no degradation due to noise using this system, and with total system linearity of 0.02/0.04/0.10%.



micro networks corporation

324 Clark St., Worcester, MA 01606
 Tel. (508) 852-5400 • FAX (508) 853-8296
 E-Mail – sales@mnc.com
 Web Site – <http://www.mnc.com>

MD3802/3805/3810

2/5/10MHz V/F, F/V Converters

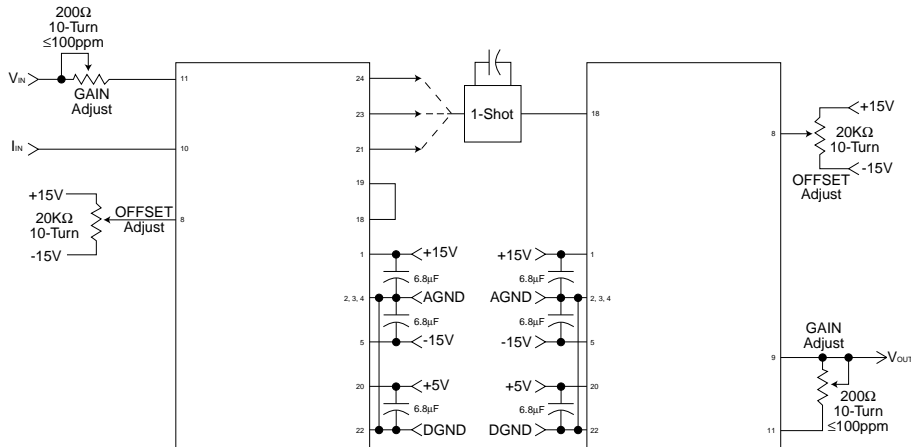

Figure 5. Analog Data Link.

Pin Designations



1 +15V Supply	24 Output
2 Analog Ground	23 Output
3 Analog Ground	22 Digital Ground
4 Analog Ground	21 $\overline{\text{Output}}$
5 -15V Supply	20 +5V Supply
6 No Connect	19 F_{OUT}
7 No Connect	18 F_{IN}
8 Offset Trim	17 No Connect
9 V_{OUT}	16 No Connect
10 I_{IN}	15 No Connect
11 V_{IN}	14 No Connect
12 No Connect	13 No Connect



micro networks corporation

324 Clark St., Worcester, MA 01606
Tel. (508) 852-5400 • FAX (508) 853-8296

E-Mail – sales@mnc.com

Web Site – <http://www.mnc.com>

Revision 1 4/98 - 5M
© Copyright 1998