

Transmitter/Receiver photo IC for optical link L10663-01, S10664-01

3.3 V operation, for MOST automotive network

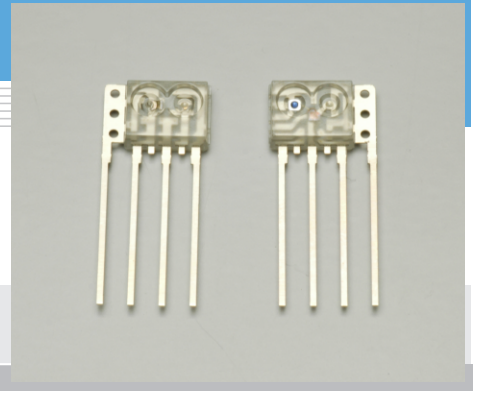

L10663-01 and S10664-01 are transmitter and receiver photo ICs developed for MOST (Media Oriented System Transport) networks used in vehicles to communicate multimedia information. Lower operating voltages in recently manufactured electronic devices have spurred demand for low-voltage and low-current transmitter/receiver photo ICs. To meet this need, HAMAMATSU has been developing low voltage (3.135 V to 3.465 V) photo ICs that still maintain a wide operating temperature range (-40 °C to +105 °C) the same as the conventional types (L10063-01/S10064-01). The transmitter photo IC L10663 consists of a Red-LED and driver IC incorporated into a clear plastic package and can be set to an operating mode that reduces the optical output level by half. The receiver photo IC S10664 features a wide dynamic range. It also has a low power consumption "sleeping mode" and an optical wakeup mode triggered by input of light. Both the transmitter and receiver photo IC input or output digital signals through a TTL interface.

Features

L10663-01

- Wide operating temperature range: -40 to +105 °C
- DC to 50 Mbps data communications
- TTL input
- Optical output 50 % cut mode

S10664-01

- Low current: 2.4 mA Max. (operating mode)
15 µA Max. (sleeping mode)
- Wide operating temperature range: -40 to +105 °C
- 4 M to 50 Mbps data communications
- TTL output
- Sleeping mode with optical wakeup
- Absolute maximum ratings *1 (Ta= -40 to +105 °C)

Parameter	Symbol	L10663, S10664	Unit
Supply voltage	Vcc	-0.5 to +7.0	V
Operating temperature	Topr	-40 to +105	°C
Storage temperature	Tstg	-40 to +120	°C
Soldering	Tsol	260 °C, 5 s, 3 times, at least 2.5 mm away from lead root	-

Applications

- Only for vehicle networks (MOST)

MOST compliant products

Specifications of these products are subject to change without prior notice to keep up with changes in the MOST standard.

L10663-01

■ Electrical and optical characteristics (Ta= -40 to +105 °C, Vcc= 3.135 to 3.465 V *1)

Parameter	Symbol	Condition	Min.	Typ.	Max.	Unit
Current consumption	Icc	Vin= 2.0 V, Rcont=13.5 kΩ	-	-	40	mA
Peak emission wavelength	λp		630	650	670	nm
Spectral half width (FWHM)	Δλ		-	20	30	nm
Fiber coupled optical output 1	Po1	Rcont=13.5 kΩ *2, *3	-9.5	-	-2	dBm
Fiber coupled optical output 2	Po2	Rcont=27 kΩ *2, *3	-13	-	-4.5	dBm
Extinction ratio	re		10	-	-	dB
Rise time at pulse drive	tr	20 to 80 % *2	-	-	5.5	ns
Fall time at pulse drive	tf	80 to 20 % *2	-	-	5.5	ns
Pulse width variation	tpwv	50 % *2, *4	19.99	-	24.29	ns
Pulse width distortion (average value)	tapwd	50 % *2, *4	-1.39	-	+1.39	ns

*1: A bypass capacitor (0.1 µF) connected between Vcc and GND at a position within 3 mm from the lead, and a 10 µF capacitor is also connected to the power supply line nearby.

The center of the optical fiber is aligned with the center of the package lens. The distance between the fiber end and the lens top is 0.1 mm.

An external resistor (Rcont) is connected between Cont and -Vcc.

*2: Measured with input signals conforming to SP1 MOST specification of physical layer Rev 1.1 Addendum B.

*3: Average value measured with a plastic fiber (φ1 mm, SI-POF, NA=0.5, 1 m) made by Mitsubishi Rayon.

*4: Measured with BiPhase PRBS at 45.2 Mbps (NRZ signal conversion).

S10664-01

■ Electrical and optical characteristics (Ta= -40 to +105 °C, Vcc=3.135 to 3.465 V *5)

Parameter	Symbol	Condition	Min.	Typ.	Max.	Unit	
Current consumption (operation mode)	Icco	*6	-	-	24	mA	
Current consumption (sleeping mode)	Iccs	Dark state	-	-	15	μA	
Receiver level	Popt3	Bi-phase signal	-25	-	-2	dBm	
Vout	High level output voltage	Voh	Ioh= -150 μm	2.5	-	Vcc+0.3	V
	Low level output voltage	Vol	Iol=1.0 mA	0	-	0.4	V
	Rise time	tr	10 to 90 % *6, *7	-	-	9	ns
	Fall time	tf		-	-	7	
Pulse width variation	tpwv	*6, *7, *8, *9	17.09	-	29.79	ns	
Pulse width distortion (average value)	tapwd	*6, *7, *8, *9	-2.69	-	+6.49	ns	
Operation to sleeping mode transition receivable level	Psl	*6, *10	-39	-	-25.5	dBm	
Sleeping mode to operation transition receivable level	Pop						
Mode output	High level voltage	Vmh	I mh= -20 μA	2.5	-	-	V
	Low level voltage	Vml	I ml=0.3 mA	-	-	0.5	V

*5: A bypass capacitor (0.1 μF) is connected between Vcc and GND at a position within 3 mm from the lead, and a 10 μF capacitor is also connected to the power supply line nearby.

The center of the optical fiber is aligned with the center of the package lens.

The distance between the fiber end and the lens top is 0.1 mm.

*6: Measured with input signals conforming to SP3 MOST specification of physical layer Rev 1.1 Addendum B.

*7: Measured with RL=50 kΩ, CL=15 pF (including parasitic capacitance such as probe, connector and evaluation circuit board pattern), and threshold voltage 1.5 V.

*8: An optical input waveform is generated with a Hamamatsu standard transmitter.

*9: Measured with BiPhase PRBS at 45.2 Mbps (NRZ signal conversion).

*10: Average optical output is measured with a POF (NA=0.5).

Note) If modulated light at 4 Mbps or less (including DC light and no light input) is input to S10664-01, the high and low levels cannot be discerned.

■ Mode output waveform (S10664-01)

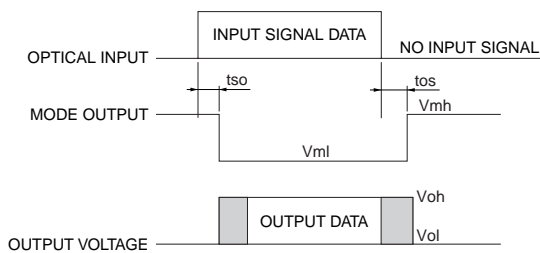

KPIC0095EA

■ Output waveform example (S10664-01)

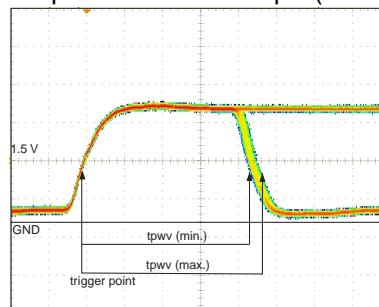

Vertical axis: 1 V/div., Horizontal axis: 5 ns/div.
 (Ta=25 °C, Vcc=3.465 V, Pi= -26 dBm,
 RL=50 kΩ, CL=15 pF, 45.2 Mbps)

■ Dimensional outlines (unit: mm)

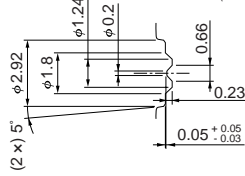
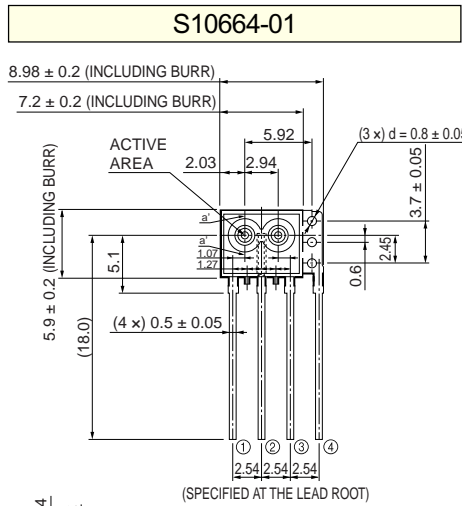
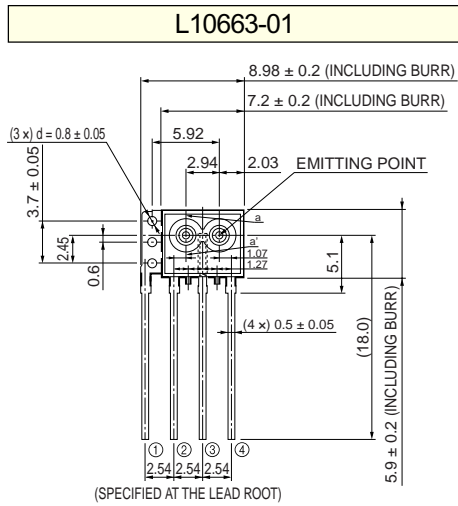

Tolerance unless otherwise noted: ±0.1, ±2' R0.3 MAX.
 Values in parentheses indicate reference value.
 Shaded area indicates burr.
 Lead material: Cu alloy with Ni/Pd/Au plating

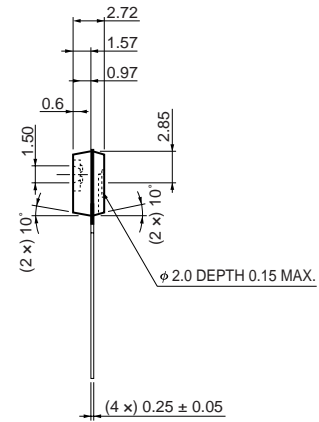

Pin No.	L10663-01	S10664-01
①	V _{IN}	V _{CC}
②	GND	GND
③	V _{CC}	MODEOUT
④	Cont	V _{OUT}

KPICA0077EA

HAMAMATSU

Information furnished by HAMAMATSU is believed to be reliable. However, no responsibility is assumed for possible inaccuracies or omissions. Specifications are subject to change without notice. No patent rights are granted to any of the circuits described herein. Type numbers of products listed in the specification sheets or supplied as samples may have a suffix "(X)" which means tentative specifications or a suffix "(Z)" which means developmental specifications. ©2010 Hamamatsu Photonics K.K.

HAMAMATSU PHOTONICS K.K., Solid State Division

1126-1 Ichino-cho, Higashi-ku, Hamamatsu City, 435-8558 Japan, Telephone: (81) 53-434-3311, Fax: (81) 53-434-5184, www.hamamatsu.com

U.S.A.: Hamamatsu Corporation: 360 Foothill Road, P.O.Box 6910, Bridgewater, N.J. 08807-0910, U.S.A., Telephone: (1) 908-231-0960, Fax: (1) 908-231-1218

Germany: Hamamatsu Photonics Deutschland GmbH: Arzbergerstr. 10, D-82211 Herrsching am Ammersee, Germany, Telephone: (49) 8152-375-0, Fax: (49) 8152-265-8

France: Hamamatsu Photonics France S.A.R.L.: 19, Rue du Saule Trapu, Parc du Moulin de Massy, 91882 Massy Cedex, France, Telephone: 33-(1) 69 53 71 00, Fax: 33-(1) 69 53 71 10

United Kingdom: Hamamatsu Photonics UK Limited: 2 Howard Court, 10 Tewin Road, Welwyn Garden City, Hertfordshire AL7 1BW, United Kingdom, Telephone: (44) 1707-294888, Fax: (44) 1707-325777

North Europe: Hamamatsu Photonics Norden AB: Smidesvägen 12, SE-171 41 Solna, Sweden, Telephone: (46) 8-509-031-00, Fax: (46) 8-509-031-01

Italy: Hamamatsu Photonics Italia S.R.L.: Strada della Moia, 1/E, 20020 Arese, (Milano), Italy, Telephone: (39) 02-935-81-733, Fax: (39) 02-935-81-741