

---

**STM8T14x ProxSense™ charge transfer capacitive sensing technology**

---

**Introduction**

This application note describes the ProxSense™<sup>(a)</sup> charge transfer capacitive sensing technology used in STMicroelectronics STM8T14x capacitive sensors.

STM8T14x devices offer a state of the art capacitive sensing engine supporting both touch and proximity sensing. They are designed to easily replace conventional electromechanical switches in cost-sensitive applications.

**Table 1. Applicable products**

Type	Applicable products
Microcontrollers	STM8T141, STM8T142 and STM8T143

---

a. ProxSense is a trademark from Azoteq.

# Contents

- 1      **Capacitive sensing overview** ..... **5****
- 1.1    Sensing electrode capacitance ..... 5
- 1.2    Principles of charge transfer ..... 5
- 1.3    Transfer rate ..... 8
  
- 2      **Revision history** ..... **10****

## List of tables

Table 1.	Applicable products .....	1
Table 2.	Charge transfer sequence .....	6
Table 3.	Document revision history .....	10

## List of figures

Figure 1.	Coupling with hand increases the capacitance of the sensing electrode . . . . .	5
Figure 2.	Depiction of channel charge-transfer hardware . . . . .	6
Figure 3.	Charge cycle . . . . .	7
Figure 4.	Voltage across $C_X$ over a charge cycle . . . . .	7
Figure 5.	Ideal transfer cycles . . . . .	7
Figure 6.	Ideal charge cycles . . . . .	8
Figure 7.	Non-ideal transfer cycles . . . . .	9
Figure 8.	Charge cycle resulting from non-ideal transfer cycles . . . . .	9

# 1 Capacitive sensing overview

## 1.1 Sensing electrode capacitance

A capacitance exists between any reference point relative to ground as long as they are electrically isolated. If this reference point is a sensing electrode, it helps to think of it as a capacitor. The positive electrode of the capacitor is the sensing electrode, and the negative electrode is formed by the surrounding area (virtual ground reference, labeled 1 in [Figure 1](#)).

**Figure 1. Coupling with hand increases the capacitance of the sensing electrode**

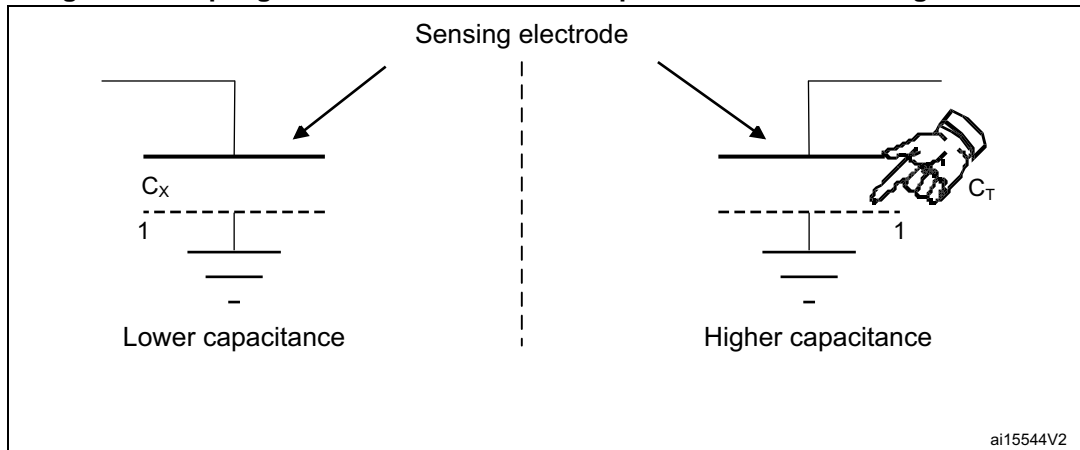

When a conductive object is brought into proximity of the sensing electrode, the coupling between the object and the electrode increases, together with the capacitance of the sensing electrode relative to ground. For example, a human hand will increase the sensing electrode capacitance as it approaches it. Touching the dielectric panel that protects the electrode increases its capacitance significantly.

The sensing electrode can be made of any electrically conductive material, such as copper on PCBs, or transparent conductive material like Indium Tin Oxide (ITO) deposited on glass or Plexiglas.

## 1.2 Principles of charge transfer

The sensing electrode is connected to the  $C_X$  pin of the STM8T14x device. The equivalent capacitance of the sensing electrode is referred to as  $C_X$ .

$C_X$  is fully charged with a stable reference voltage  $V_{DD}$ . The charge on  $C_X$  is then transferred to a sampling capacitor ( $C_S$ ).  $C_S$  capacitance is typically from 1000 to 100,000 times bigger than  $C_X$ . The process is repeated until the voltage on  $C_S$  reaches a threshold. This threshold is referred to as  $V_{TRIP}$ . The number of transfer cycles required to reach the threshold represents the size of  $C_X$ . Refer to [Figure 4](#) and [Table 2](#) for a representation of the charge-transfer equivalent hardware and charge-transfer sequence for a given channel.

Figure 2. Depiction of channel charge-transfer hardware

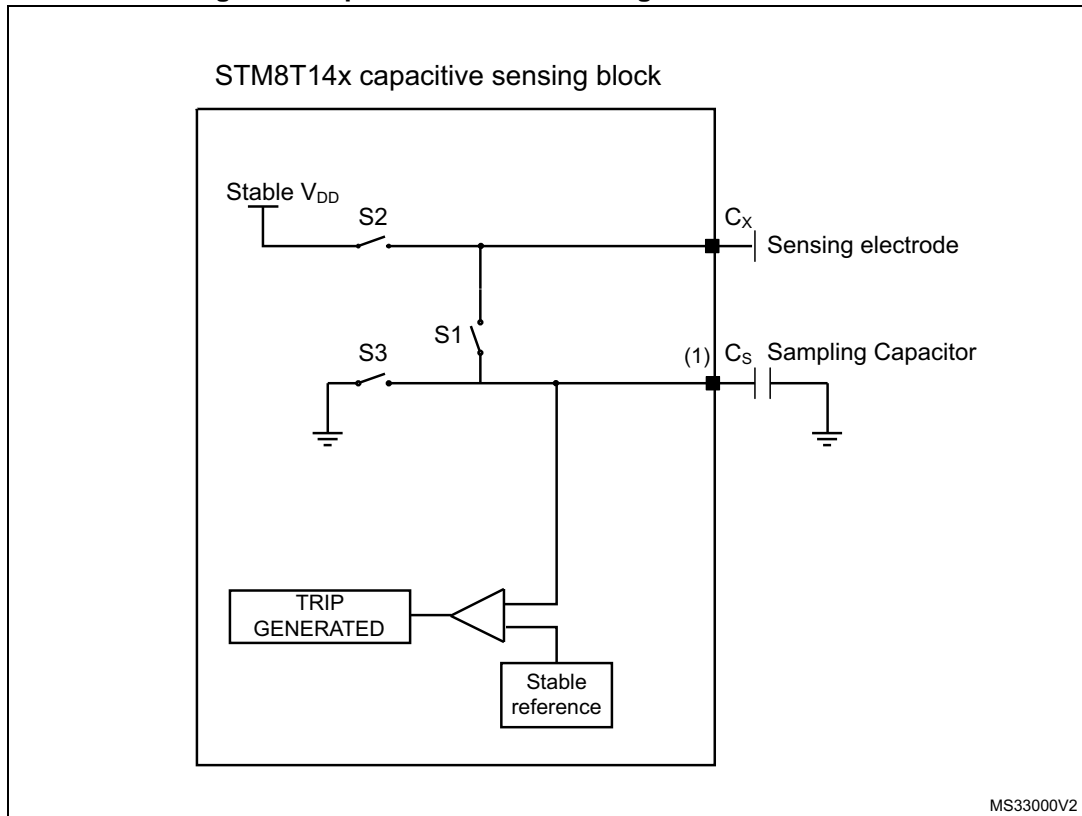

1. This pin is only available on the STM8T141. On STM8T142 and STM8T143 devices, the sampling capacitor is integrated within the product.

Table 2. Charge transfer sequence <sup>(1)</sup>

Step	Switch S3	Switch S2	Switch S1	Description
1	1	0	1	C <sub>S</sub> discharge
2	0	0	0	Deadtime
3	0	1	0	Charge cycle (C <sub>X</sub> charge)
4	0	0	0	Deadtime
5	0	0	1	Transfer cycle (charge transferred to C <sub>S</sub> )
6	0	0	0	Deadtime
7	1	0	1	C <sub>X</sub> discharge

1. Step 2 to 7 are repeated until the voltage across C<sub>S</sub> reaches V<sub>TRIP</sub> threshold.

The **transfer cycle** refers to the charging of C<sub>X</sub> and the transfer of the charge to the C<sub>S</sub> capacitor. The **charge cycle** refers to process of charging C<sub>S</sub> to V<sub>TRIP</sub> using a sequence of transfer cycles. The charge cycle duration refers to the time needed to complete one C<sub>S</sub> charge cycle when no proximity or touch (thus the longest duration of a charge cycle with the current system parameters). It is graphically illustrated in [Figure 3](#).

Figure 3. Charge cycle

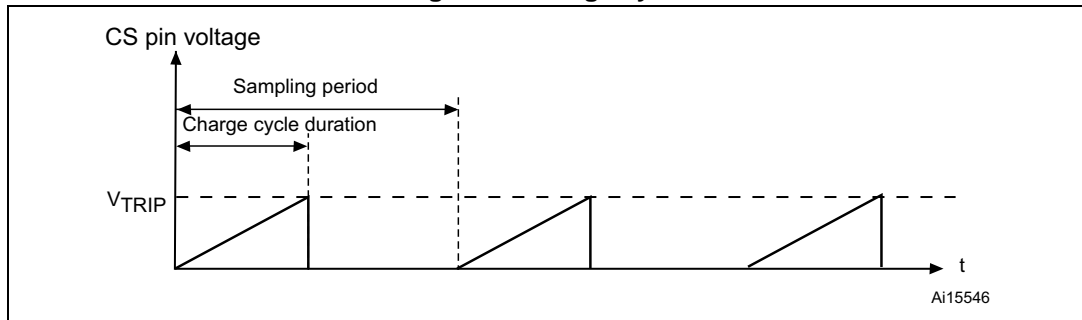

The charge cycles can be probed from the  $C_S$  pin (STM8T141 only) or from the  $C_X$  pin. [Figure 4](#) and [Figure 5](#) show the evolution of the  $C_X$  voltage during the charge and transfer cycles.

Figure 4. Voltage across  $C_X$  over a charge cycle

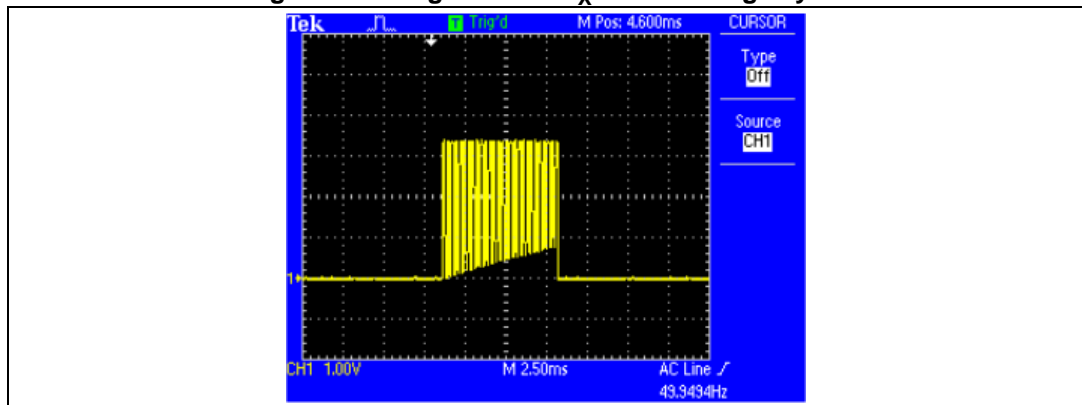
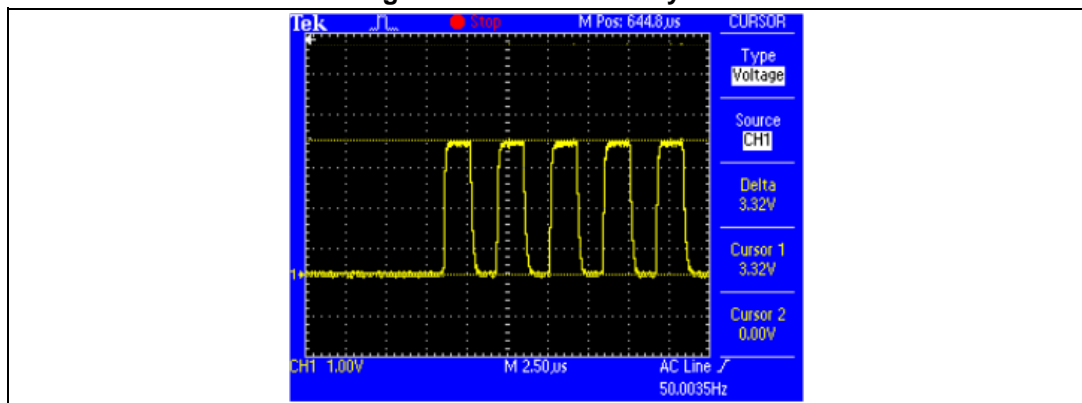

Figure 5. Ideal transfer cycles



In addition, the devices can compensate to environmental changes by tracking the average capacitance of the sensing electrode. This average value is compared to the latest charge cycle to determine whether a proximity or touch occurred.

### 1.3 Transfer rate

The transfer cycles can be performed at a default rate depending on the internal oscillator frequency. According to the device, this frequency can be modified either through OTP option bytes.

The oscillator is used to determine the rate at which the charge transfers is performed. A maximum efficiency is achieved when enough time is allowed to fully charge  $C_X$  to  $V_{DD}$  and completely transfer this charge to the  $C_S$  capacitor.

A transfer rate between 100 kHz and 250 kHz is a good choice in normal operating conditions. The default transfer rate is in this range.

A serial resistor  $R_X$  connected to the  $C_X$  pin negatively influences the transfer cycle. This resistor improves the conductive object electrical isolation from the sensing electrode and provides additional ESD protection for the device. Typical  $R_X$  value ranges from 1 to 2k $\Omega$ .

*Figure 5* and *Figure 6* show ideal charge cycles probed from the  $C_X$  pin. In *Figure 5*, it can be noted that the sensing electrode charges up to  $V_{DD}$ . In *Figure 6*, the charge cycle halts when  $V_{TRIP}$  is reached.

**Figure 6. Ideal charge cycles**

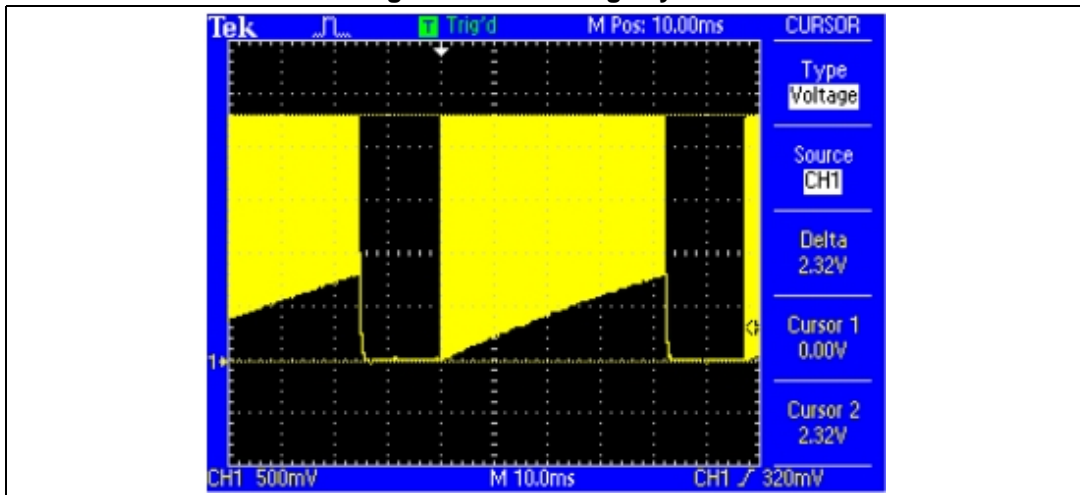

*Figure 7* and *Figure 8* shows non-ideal charge transfers and the resulting charge cycle.

It can be noted that the sensing electrode is charged up to 2.12 V instead of  $V_{DD}$ . By comparing *Figure 8* to *Figure 6*, it can be noted that the offset is due to the fact that a fraction of the sensing electrode charge is not transferred to the  $C_S$  capacitor. This can be corrected by decreasing either the transfer rate or  $R_X$ .



Figure 7. Non-ideal transfer cycles

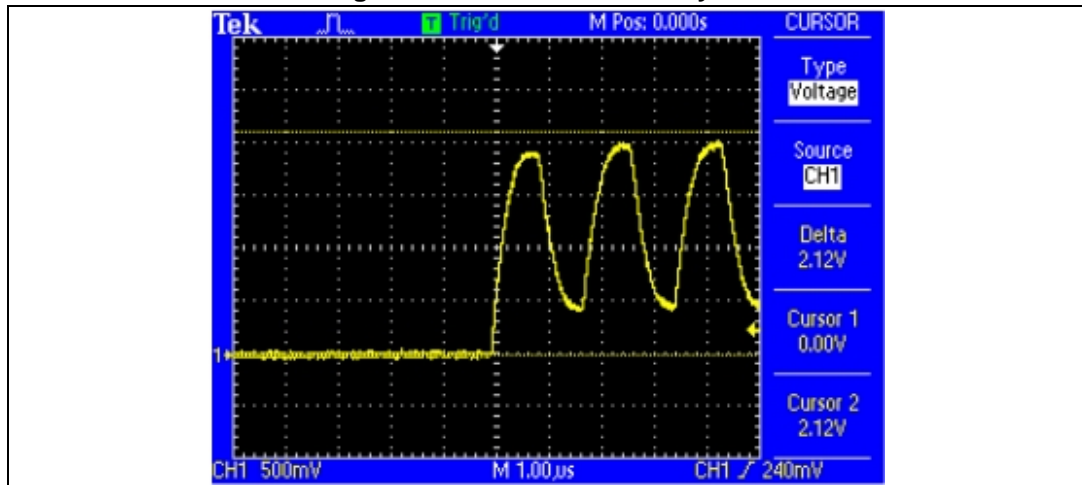
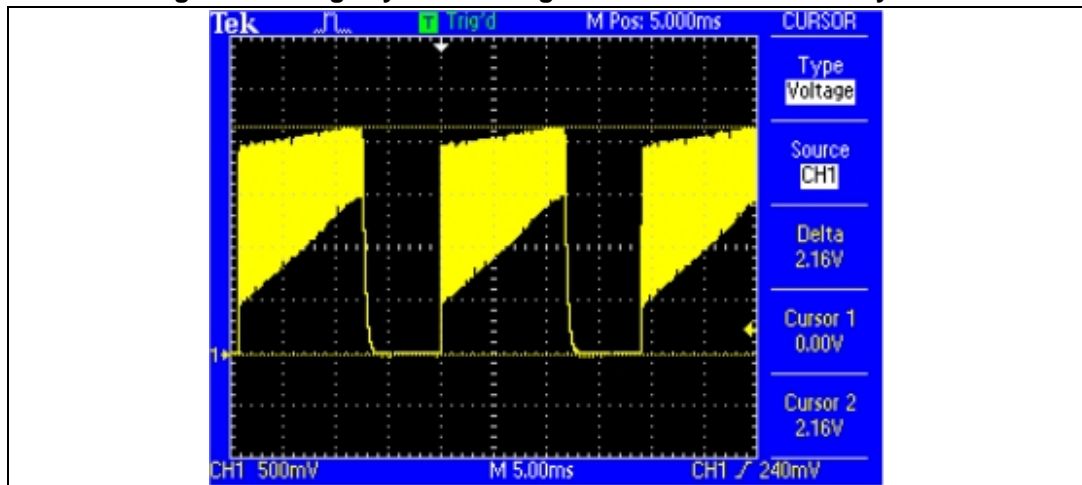

Figure 8. Charge cycle resulting from non-ideal transfer cycles



*Note:* Attaching a probe to the sensing electrode increases the sensing electrode capacitance by a few picoFarads, depending on the probe. This has an instant negative influence on the sensitivity of the system. After a short period of time, the system automatically adjusts to compensate this change.

## 2 Revision history

**Table 3. Document revision history**

Date	Revision	Changes
04-May-2009	1	Initial release.
12-Sep-2013	2	Replaced “STM8T and STM8TS” with “STM8T14x”. Updated <i>Introduction</i> . Updated <i>Figure 2: Depiction of channel charge-transfer hardware</i> . Added Table Of Content (TOC), List Of Tables (LOT), List Of Figures (LOF). Added <i>Table 1: Applicable products</i> . Updated titles: <i>Figure 1: Coupling with hand increases the capacitance of the sensing electrode</i> . <i>Figure 7: Non-ideal transfer cycles</i> . <i>Figure 8: Charge cycle resulting from non-ideal transfer cycles</i> . Transfer rate updated as 250 kHz in <i>Section 1.3: Transfer rate</i> .

**Please Read Carefully:**

Information in this document is provided solely in connection with ST products. STMicroelectronics NV and its subsidiaries ("ST") reserve the right to make changes, corrections, modifications or improvements, to this document, and the products and services described herein at any time, without notice.

All ST products are sold pursuant to ST's terms and conditions of sale.

Purchasers are solely responsible for the choice, selection and use of the ST products and services described herein, and ST assumes no liability whatsoever relating to the choice, selection or use of the ST products and services described herein.

No license, express or implied, by estoppel or otherwise, to any intellectual property rights is granted under this document. If any part of this document refers to any third party products or services it shall not be deemed a license grant by ST for the use of such third party products or services, or any intellectual property contained therein or considered as a warranty covering the use in any manner whatsoever of such third party products or services or any intellectual property contained therein.

**UNLESS OTHERWISE SET FORTH IN ST'S TERMS AND CONDITIONS OF SALE ST DISCLAIMS ANY EXPRESS OR IMPLIED WARRANTY WITH RESPECT TO THE USE AND/OR SALE OF ST PRODUCTS INCLUDING WITHOUT LIMITATION IMPLIED WARRANTIES OF MERCHANTABILITY, FITNESS FOR A PARTICULAR PURPOSE (AND THEIR EQUIVALENTS UNDER THE LAWS OF ANY JURISDICTION), OR INFRINGEMENT OF ANY PATENT, COPYRIGHT OR OTHER INTELLECTUAL PROPERTY RIGHT.**

**ST PRODUCTS ARE NOT AUTHORIZED FOR USE IN WEAPONS. NOR ARE ST PRODUCTS DESIGNED OR AUTHORIZED FOR USE IN: (A) SAFETY CRITICAL APPLICATIONS SUCH AS LIFE SUPPORTING, ACTIVE IMPLANTED DEVICES OR SYSTEMS WITH PRODUCT FUNCTIONAL SAFETY REQUIREMENTS; (B) AERONAUTIC APPLICATIONS; (C) AUTOMOTIVE APPLICATIONS OR ENVIRONMENTS, AND/OR (D) AEROSPACE APPLICATIONS OR ENVIRONMENTS. WHERE ST PRODUCTS ARE NOT DESIGNED FOR SUCH USE, THE PURCHASER SHALL USE PRODUCTS AT PURCHASER'S SOLE RISK, EVEN IF ST HAS BEEN INFORMED IN WRITING OF SUCH USAGE, UNLESS A PRODUCT IS EXPRESSLY DESIGNATED BY ST AS BEING INTENDED FOR "AUTOMOTIVE, AUTOMOTIVE SAFETY OR MEDICAL" INDUSTRY DOMAINS ACCORDING TO ST PRODUCT DESIGN SPECIFICATIONS. PRODUCTS FORMALLY ESCC, QML OR JAN QUALIFIED ARE DEEMED SUITABLE FOR USE IN AEROSPACE BY THE CORRESPONDING GOVERNMENTAL AGENCY.**

Resale of ST products with provisions different from the statements and/or technical features set forth in this document shall immediately void any warranty granted by ST for the ST product or service described herein and shall not create or extend in any manner whatsoever, any liability of ST.

ST and the ST logo are trademarks or registered trademarks of ST in various countries.

Information in this document supersedes and replaces all information previously supplied.

The ST logo is a registered trademark of STMicroelectronics. All other names are the property of their respective owners.

© 2013 STMicroelectronics - All rights reserved

STMicroelectronics group of companies

Australia - Belgium - Brazil - Canada - China - Czech Republic - Finland - France - Germany - Hong Kong - India - Israel - Italy - Japan - Malaysia - Malta - Morocco - Philippines - Singapore - Spain - Sweden - Switzerland - United Kingdom - United States of America

[www.st.com](http://www.st.com)

