

**18V, 2A Synchronous DC-DC Buck Converter****AP3512E****General Description**

The AP3512E is a 500kHz fixed frequency, current mode, PWM synchronous buck (step-down) DC-DC converter, capable of driving a 2A load with high efficiency, excellent line and load regulation. The AP3512E exhibits high efficiency at light load. The device integrates N-channel power MOSFET switch with low on-resistance. Current mode control provides fast transient response and cycle-by-cycle current limit.

The AP3512E employs complete protection to ensure system security, including output Over Voltage Protection, input Under Voltage Lock Out, programmable Soft-start, Over Temperature Protection and hiccup mode Short Circuit Protection.

This IC is available in SOIC-8 and PSOP-8 packages.

**Features**

- Input Voltage Range: 4.5V to 18V
- Fixed 500kHz Frequency
- High Efficiency at Light Load
- Output Current: 2A
- Current Mode Control
- Built-in Over Current Protection
- Built-in Thermal Shutdown Function
- Built-in UVLO Function
- Built-in Over Voltage Protection
- Programmable Soft-start
- Hiccup Mode SCP

**Applications**

- Monitor
- TV
- STB
- Datacom

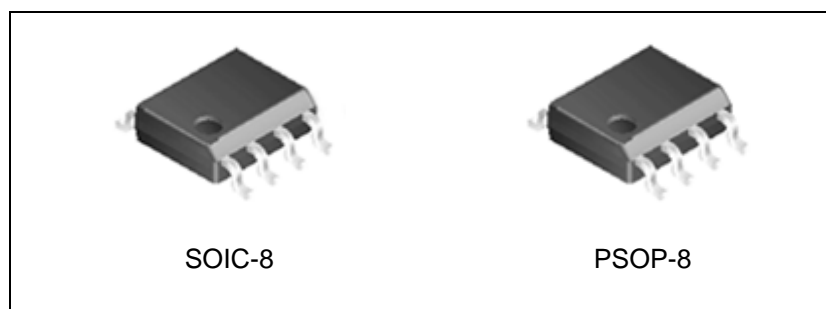

Figure 1. Package Types of AP3512E

**18V, 2A Synchronous DC-DC Buck Converter**
**AP3512E**
**Pin Configuration**

Figure 2. Pin Configuration of AP3512E (Top View)

**Pin Description**

Pin Number	Pin Name	Function
1	BS	Bootstrap pin. A bootstrap capacitor is connected between the BS pin and SW pin. The voltage across the bootstrap capacitor drives the internal high-side NMOS switch.
2	IN	Supply input pin. A capacitor should be connected between the IN pin and GND pin to keep the DC input voltage constant.
3	SW	Power switch output pin. This pin is connected to the inductor and bootstrap capacitor.
4	GND	Ground pin
5	FB	Feedback pin. This pin is connected to an external resistor divider to program the system output voltage. When the FB pin voltage exceeds 1.1V, the over voltage protection is triggered. When the FB pin voltage is below 0.3V, the oscillator frequency is lowered to realize short circuit protection.
6	COMP	Compensation pin. This pin is the output of the transconductance error amplifier and the input to the current comparator. This pin is used to compensate the control loop. Connect a series RC network from this pin to GND pin. In some cases, an additional capacitor from this pin to GND pin is required.
7	EN	Enable Input. EN is a digital input that turns the regulator on or off. Drive EN high to turn on the regulator, drive it low to turn off. Pull up with 100kΩ resistor for automatic startup.
8	SS	Soft-start control input pin. SS controls the soft start period. Connect a capacitor from SS to GND to set the soft-start period. A 0.1μF capacitor sets the soft-start period to 15ms. To disable the soft-start feature, leave SS unconnected.
	EP	Exposed pad. It should be connected to GND in PCB layout

**18V, 2A Synchronous DC-DC Buck Converter**

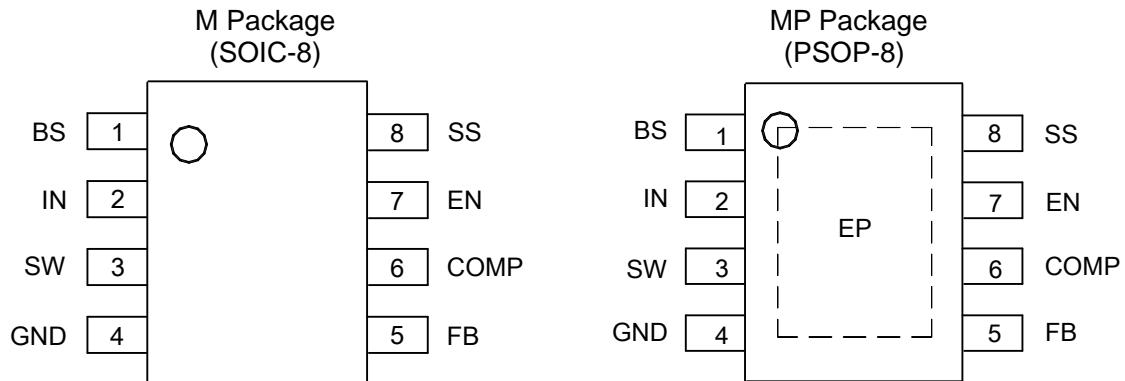
**AP3512E**

**Functional Block Diagram**

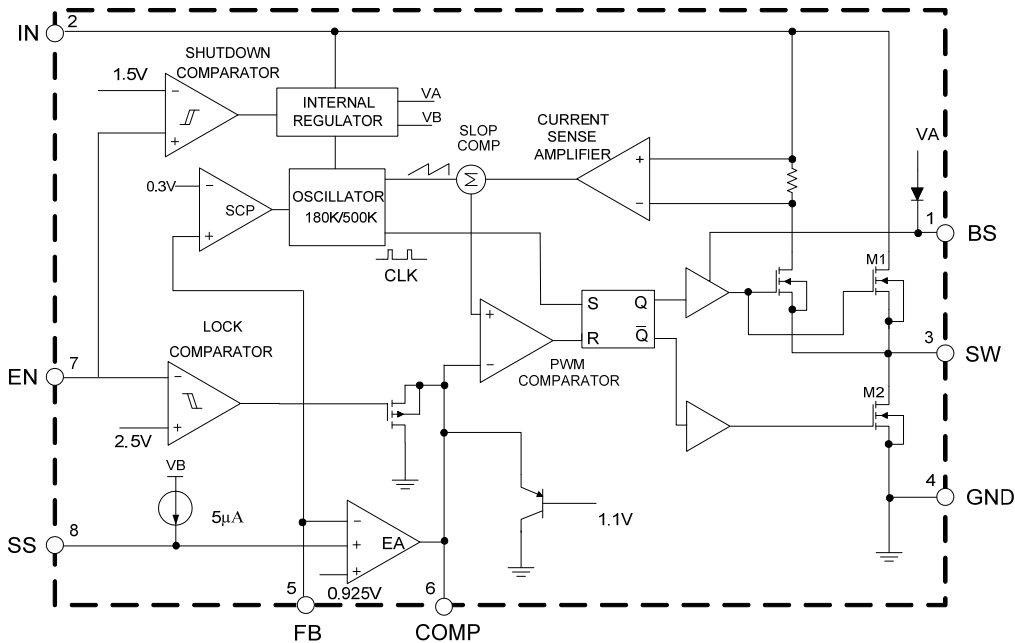
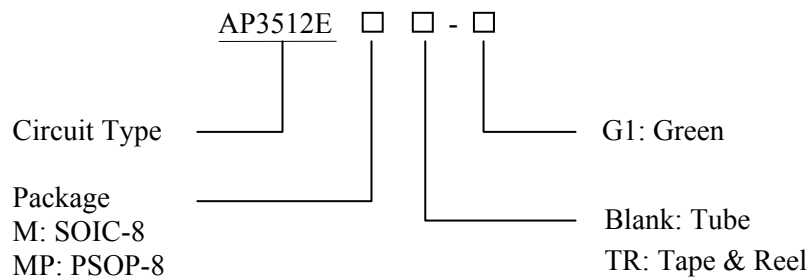

Figure 3. Functional Block Diagram of AP3512E

**Ordering Information**



Package	Temperature Range	Part Number	Marking ID	Packing Type
SOIC-8	-40 to 85°C	AP3512EM-G1	3512EM-G1	Tube
		AP3512EMTR-G1	3512EM-G1	Tape & Reel
PSOP-8	-40 to 85°C	AP3512EMPTR-G1	3512EMP-G1	Tape & Reel

BCD Semiconductor's Pb-free products, as designated with "G1" suffix in the part number, are RoHS compliant and green.

**18V, 2A Synchronous DC-DC Buck Converter****AP3512E****Absolute Maximum Ratings (Note 1)**

Parameter	Symbol	Value	Unit	
IN Pin Voltage	$V_{IN}$	-0.3 to 20	V	
EN Pin Voltage	$V_{EN}$	-0.3 to $V_{IN}$	V	
SW Pin Voltage	$V_{SW}$	21	V	
BS Pin Voltage	$V_{BS}$	-0.3 to $V_{SW}+6$	V	
FB Pin Voltage	$V_{FB}$	-0.3 to 6	V	
COMP Pin Voltage	$V_{COMP}$	-0.3 to 6	V	
SS Pin Voltage	$V_{SS}$	-0.3 to 6	V	
Operating Junction Temperature	$T_J$	150	°C	
Storage Temperature	$T_{STG}$	-65 to 150	°C	
Lead Temperature (Soldering, 10sec)	$T_{LEAD}$	260	°C	
Thermal Resistance (Junction to Ambient)	$\theta_{JA}$	SOIC-8	105	°C/W
		PSOP-8	60	
ESD (Human Body Model)	$V_{HBM}$	2000	V	
ESD (Machine Model)	$V_{MM}$	200	V	

Note 1: Stresses greater than those listed under “Absolute Maximum Ratings” may cause permanent damage to the device. These are stress ratings only, and functional operation of the device at these or any other conditions beyond those indicated under “Recommended Operating Conditions” is not implied. Exposure to “Absolute Maximum Ratings” for extended periods may affect device reliability.

**Recommended Operating Conditions**

Parameter	Symbol	Min	Max	Unit
Input Voltage	$V_{IN}$	4.5	18	V
Operating Ambient Temperature	$T_A$	-40	85	°C



**18V, 2A Synchronous DC-DC Buck Converter**

**AP3512E**

**Electrical Characteristics**

$V_{IN}=V_{EN}=12V$ ,  $V_{OUT}=3.3V$ ,  $T_A=25^{\circ}C$ , unless otherwise specified.

Parameter	Symbol	Conditions	Min	Typ	Max	Unit
<b>SUPPLY VOLTAGE (IN PIN)</b>						
Input Voltage	$V_{IN}$		4.5		18	V
Quiescent Current	$I_Q$	$V_{FB}=1V$ , $V_{EN}=3.3V$		1.2	1.4	mA
Shutdown Supply Current	$I_{SHDN}$	$V_{EN}=0V$		0.1	1.0	$\mu A$
<b>UNDER VOLTAGE LOCKOUT</b>						
Input UVLO Threshold	$V_{UVLO}$	$V_{IN}$ Rising	3.65	4.0	4.25	V
Input UVLO Hysteresis	$V_{HYS}$			0.2		V
<b>ENABLE (EN PIN)</b>						
EN Shutdown Threshold Voltage			1.1	1.5	2	V
EN Shutdown Threshold Voltage Hysteresis (Note 2)				350		mV
EN Lockout Threshold Voltage			2.2	2.5	2.7	V
EN Lockout Hysteresis				210		mV
<b>VOLTAGE REFERENCE (FB PIN)</b>						
Feedback Voltage	$V_{FB}$		0.907	0.925	0.943	V
Feedback Over Voltage Threshold	$V_{FBOV}$			1.1		V
Feedback Bias Current	$I_{FB}$	$V_{FB}=1V$	-0.1		0.1	$\mu A$
<b>MOSFET</b>						
High-side Switch On-resistance (Note 3)	$R_{DS(ON)H}$	$I_{SW}=0.2A\&0.7A$		100		m $\Omega$
Low-side Switch On-resistance (Note 3)	$R_{DS(ON)L}$	$I_{SW}=-0.2A\&-0.7A$		100		m $\Omega$
<b>CURRENT LIMIT</b>						
High-side Switch Leakage Current	$I_{LEAKH}$	$V_{IN}=18V$ , $V_{EN}=0V$ , $V_{SW}=0V$		0.1	10	$\mu A$
High-side Switch Current Limit	$I_{LIMH}$		4.3	5.6		A
Low-side Switch Current Limit	$I_{LIML}$	From drain to source		50		mA
<b>SWITCHING REGULATOR</b>						
Oscillator Frequency	$f_{OSC1}$		410	500	590	kHz
Short Circuit Oscillator Frequency	$f_{OSC2}$			180		kHz

**18V, 2A Synchronous DC-DC Buck Converter****AP3512E****Electrical Characteristics (Continued)** $V_{IN}=V_{EN}=12V$ ,  $V_{OUT}=3.3V$ ,  $T_A=25^\circ C$ , unless otherwise specified.

Parameter	Symbol	Conditions	Min	Typ	Max	Unit
Max. Duty Cycle	$D_{MAX}$	$V_{FB}=0.85V$		90		%
Min. Duty Cycle	$D_{MIN}$	$V_{FB}=1V$			0	%
<b>ERROR AMPLIFIER</b>						
Error Amplifier Voltage Gain (Note 2)	$A_{EA}$			400		V/V
Error Amplifier Transconductance	$G_{EA}$			800		$\mu A/V$
COMP to Current Sense Transconductance	$G_{CS}$			5.2		A/V
<b>THERMAL SHUTDOWN</b>						
Thermal Shutdown (Note 2)	$T_{OTSD}$			160		$^\circ C$
Thermal Shutdown Hysteresis (Note 2)	$T_{HYS}$			30		$^\circ C$
<b>SOFT START (SS PIN)</b>						
Soft-start Time (Note 2)	$t_{SS}$	$C_{SS}=0.1\mu F$		15		ms
Soft-start Current				5		$\mu A$

Note 2: Not tested, guaranteed by design.

$$\text{Note 3: } R_{DS(on)} = \frac{V_{SW1} - V_{SW2}}{I_{SW1} - I_{SW2}}$$



**18V, 2A Synchronous DC-DC Buck Converter**

**AP3512E**

**Typical Performance Characteristics**

$V_{IN}=12V$ ,  $V_{OUT}=3.3V$ ,  $L=4.7\mu H$ ,  $T_A=25^\circ C$ , unless otherwise noted.

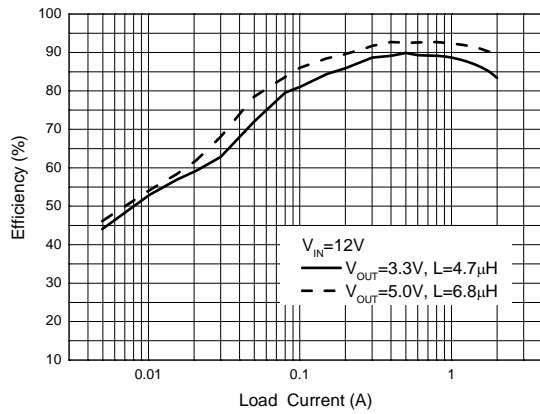

Figure 4. Efficiency vs. Load Current

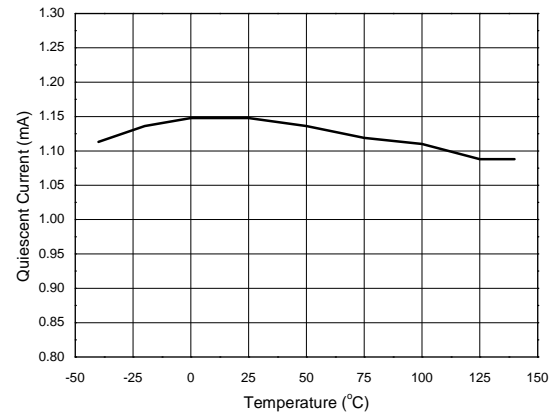

Figure 5. Quiescent Current vs. Temperature

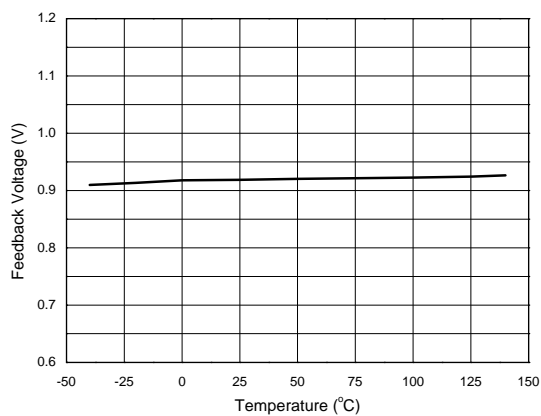

Figure 6. Feedback Voltage vs. Temperature

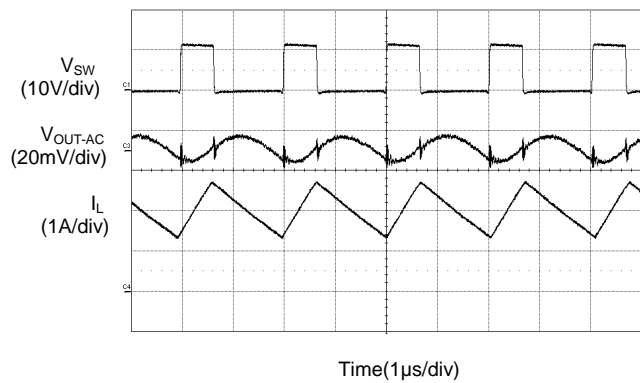

Figure 7. Output Ripple ( $I_{OUT}=2A$ )



**18V, 2A Synchronous DC-DC Buck Converter**

**AP3512E**

**Typical Performance Characteristics (Continued)**

$V_{IN}=12V$ ,  $V_{OUT}=3.3V$ ,  $L=4.7\mu H$ ,  $T_A=25^\circ C$ , unless otherwise noted.

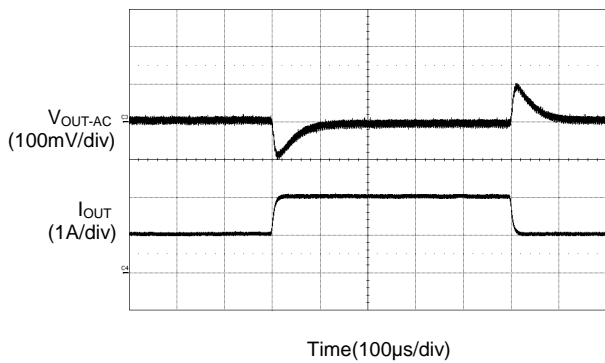

Figure 8. Load Transient Response ( $I_{OUT}=1A$  to  $2A$ )

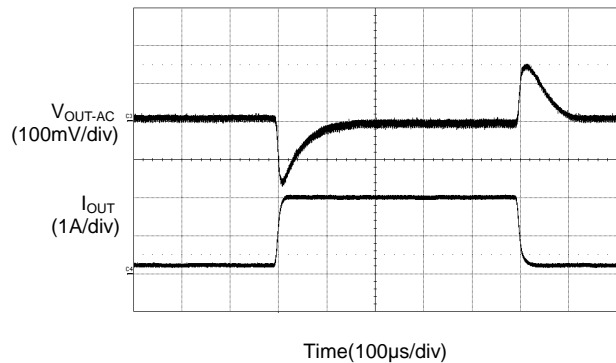

Figure 9. Load Transient Response ( $I_{OUT}=0.2A$  to  $2A$ )

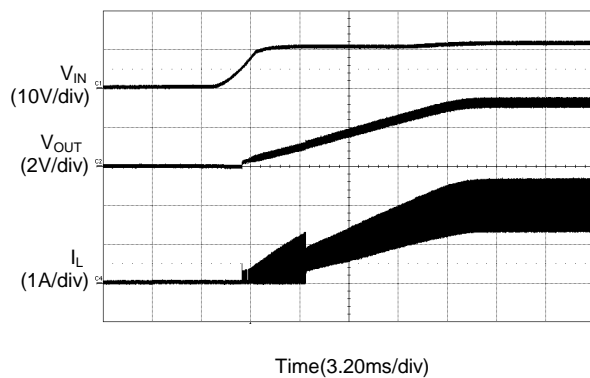

Figure 10. Power On from  $V_{IN}$  ( $I_{OUT}=2A$ )

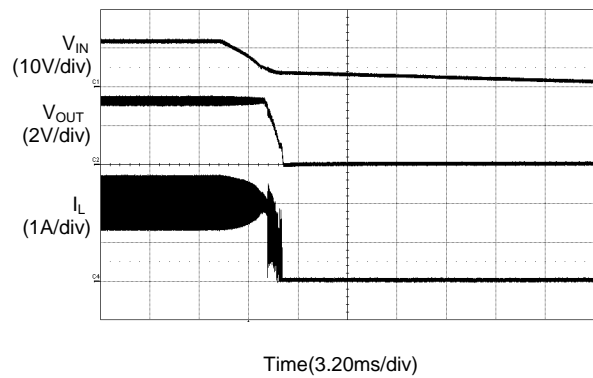

Figure 11. Power Off from  $V_{IN}$  ( $I_{OUT}=2A$ )



**18V, 2A Synchronous DC-DC Buck Converter**

**AP3512E**

**Typical Performance Characteristics (Continued)**

$V_{IN}=12V$ ,  $V_{OUT}=3.3V$ ,  $L=4.7\mu H$ ,  $T_A=25^\circ C$ , unless otherwise noted.

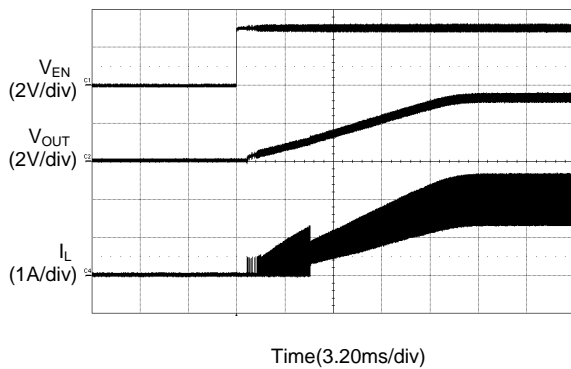

Figure 12. Power On from EN ( $I_{OUT}=2A$ )

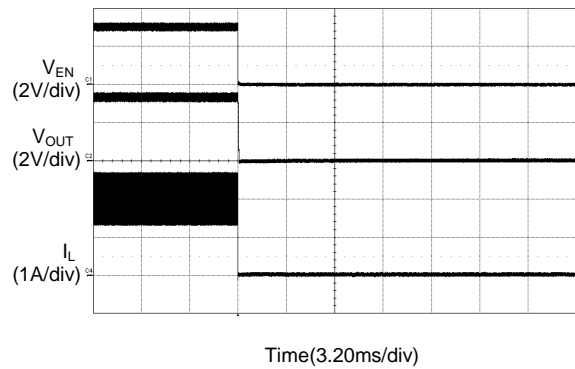

Figure 13. Power Off from EN ( $I_{OUT}=2A$ )

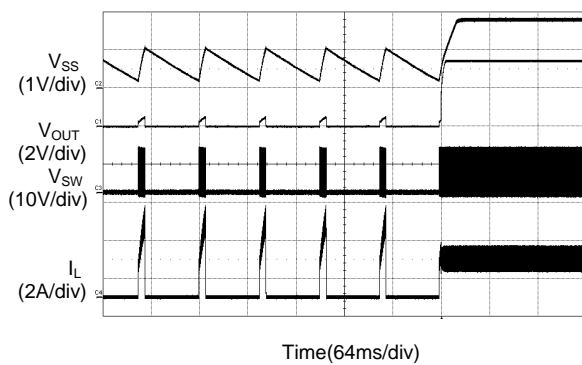

Figure 14. Short Circuit Protection ( $I_{OUT}=2A$ )

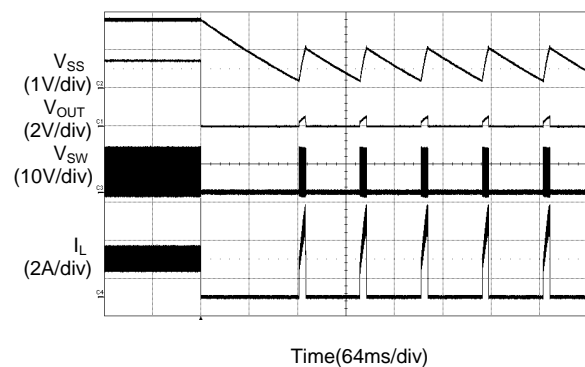

Figure 15. Short Circuit Protection Recovery ( $I_{OUT}=2A$ )

**18V, 2A Synchronous DC-DC Buck Converter**

**AP3512E**

**Typical Application**

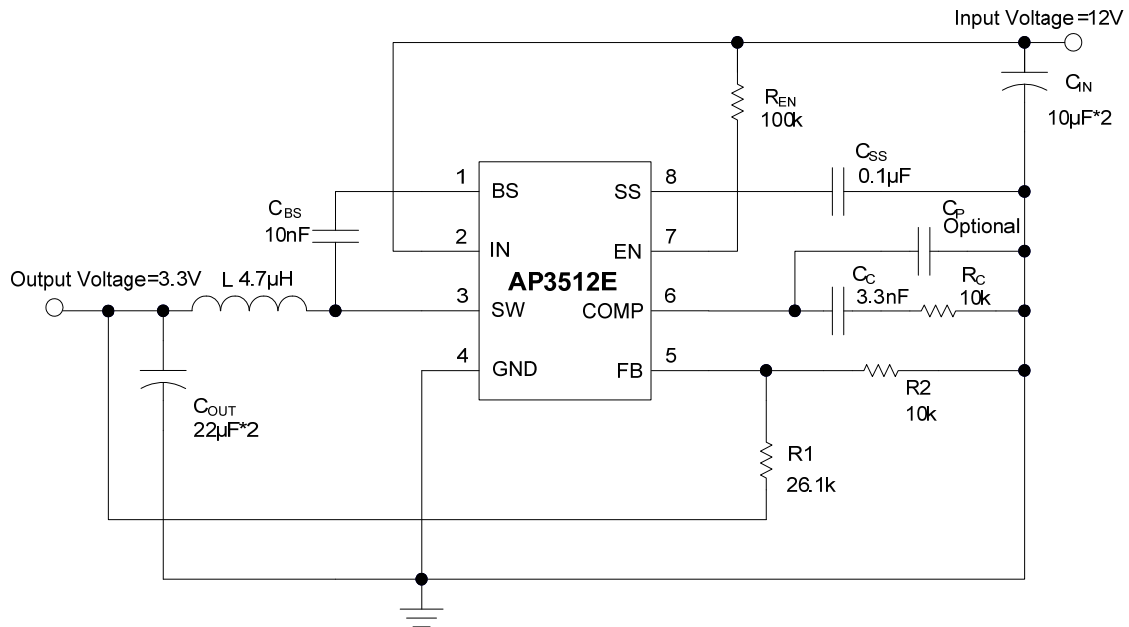

Figure 16. Typical Application Circuit of AP3512E



**18V, 2A Synchronous DC-DC Buck Converter**

**AP3512E**

**Mechanical Dimensions (Continued)**

**PSOP-8**

**Unit: mm(inch)**

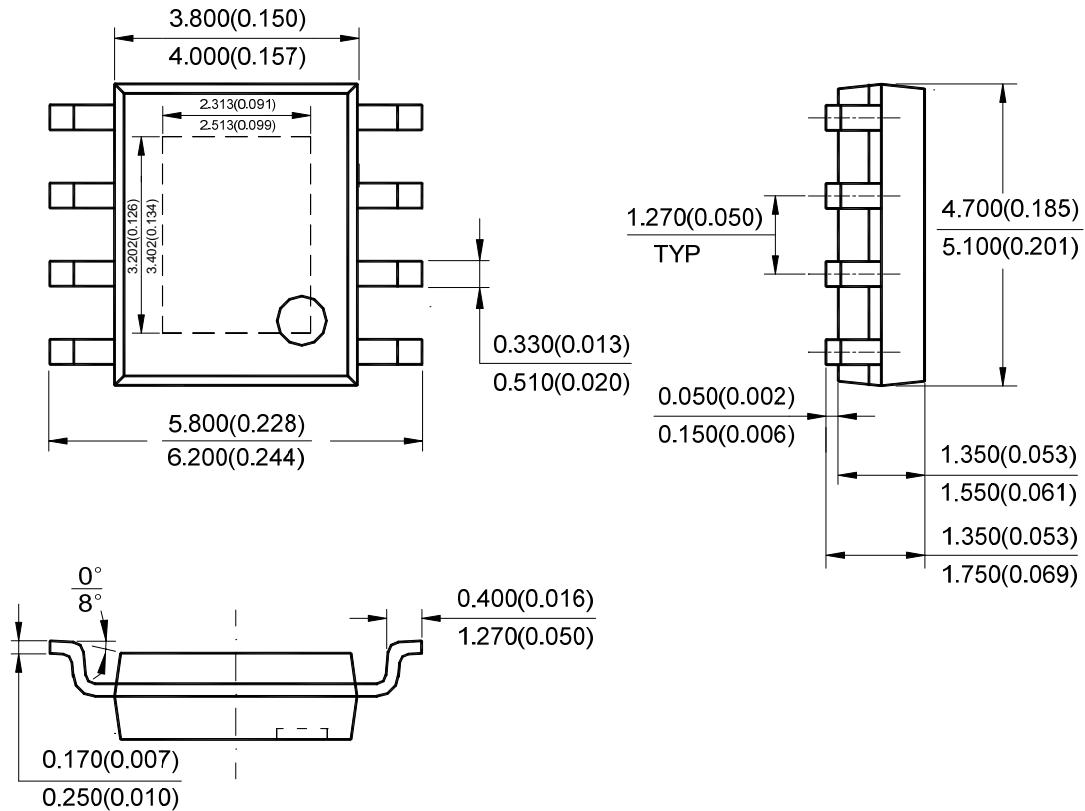

Note: Eject hole, oriented hole and mold mark is optional.



## **BCD Semiconductor Manufacturing Limited**

<http://www.bcdsemi.com>

### **IMPORTANT NOTICE**

BCD Semiconductor Manufacturing Limited reserves the right to make changes without further notice to any products or specifications herein. BCD Semiconductor Manufacturing Limited does not assume any responsibility for use of any its products for any particular purpose, nor does BCD Semiconductor Manufacturing Limited assume any liability arising out of the application or use of any its products or circuits. BCD Semiconductor Manufacturing Limited does not convey any license under its patent rights or other rights nor the rights of others.

---

#### **MAIN SITE**

##### **- Headquarters**

##### **BCD Semiconductor Manufacturing Limited**

No. 1600, Zi Xing Road, Shanghai ZiZhu Science-based Industrial Park, 200241, China  
Tel: +86-21-24162266, Fax: +86-21-24162277

##### **- Wafer Fab**

##### **Shanghai SIM-BCD Semiconductor Manufacturing Co., Ltd.**

800 Yi Shan Road, Shanghai 200233, China  
Tel: +86-21-6485 1491, Fax: +86-21-5450 0008

#### **REGIONAL SALES OFFICE**

##### **Shenzhen Office**

##### **Shanghai SIM-BCD Semiconductor Manufacturing Co., Ltd., Shenzhen Office**

Unit A Room 1203, Skyworth Bldg., Gaoxin Ave. 1.S., Nanshan District, Shenzhen, China  
Tel: +86-755-8826 7951  
Fax: +86-755-8826 7865

##### **Taiwan Office**

##### **BCD Semiconductor (Taiwan) Company Limited**

4F, 298-1, Rui Guang Road, Nei-Hu District, Taipei, Taiwan  
Tel: +886-2-2656 2808  
Fax: +886-2-2656 2806

##### **USA Office**

##### **BCD Semiconductor Corp.**

30920 Huntwood Ave. Hayward, CA 94544, USA  
Tel : +1-510-324-2988  
Fax: +1-510-324-2788